

Setup Guide

For complete user's manual
go to
www.extron.com



IN1502

Video Scaler

Precautions

Safety Instructions • English



This symbol is intended to alert the user of important operating and maintenance (servicing) instructions in the literature provided with the equipment.



This symbol is intended to alert the user of the presence of uninsulated dangerous voltage within the product's enclosure that may present a risk of electric shock.

Caution

Read Instructions • Read and understand all safety and operating instructions before using the equipment.

Retain Instructions • The safety instructions should be kept for future reference.

Follow Warnings • Follow all warnings and instructions marked on the equipment or in the user information.

Avoid Attachments • Do not use tools or attachments that are not recommended by the equipment manufacturer because they may be hazardous.

Consignes de Sécurité • Français



Ce symbole sert à avertir l'utilisateur que la documentation fournie avec le matériel contient des instructions importantes concernant l'exploitation et la maintenance (réparation).



Ce symbole sert à avertir l'utilisateur de la présence dans le boîtier de l'appareil de tensions dangereuses non isolées posant des risques d'électrocution.

Attention

Lire les instructions • Prendre connaissance de toutes les consignes de sécurité et d'exploitation avant d'utiliser le matériel.

Conservier les instructions • Ranger les consignes de sécurité afin de pouvoir les consulter à l'avenir.

Respecter les avertissements • Observer tous les avertissements et consignes marqués sur le matériel ou présents dans la documentation utilisateur.

Éviter les pièces de fixation • Ne pas utiliser de pièces de fixation ni d'outils non recommandés par le fabricant du matériel car cela risquerait de poser certains dangers.

Sicherheitsanleitungen • Deutsch



Dieses Symbol soll dem Benutzer in der im Lieferumfang enthaltenen Dokumentation besonders wichtige Hinweise zur Bedienung und Wartung (Instandhaltung) geben.



Dieses Symbol soll den Benutzer darauf aufmerksam machen, daß im Inneren des Gehäuses dieses Produktes gefährliche Spannungen, die nicht isoliert sind und die einen elektrischen Schock verursachen können, herrschen.

Achtung

Lesen der Anleitungen • Bevor Sie das Gerät zum ersten Mal verwenden, sollten Sie alle Sicherheits- und Bedienungsanleitungen genau durchlesen und verstehen.

Aufbewahren der Anleitungen • Die Hinweise zur elektrischen Sicherheit des Produktes sollten Sie aufbewahren, damit Sie im Bedarfsfall darauf zurückgreifen können.

Befolgen der Warnhinweise • Befolgen Sie alle Warnhinweise und Anleitungen auf dem Gerät oder in der Benutzerdokumentation.

Keine Zusatzgeräte • Verwenden Sie keine Werkzeuge oder Zusatzgeräte, die nicht ausdrücklich vom Hersteller empfohlen wurden, da diese eine Gefahrenquelle darstellen können.

Instrucciones de seguridad • Español



Este símbolo se utiliza para advertir al usuario sobre instrucciones importantes de operación y mantenimiento (o cambio de partes) que se desean destacar en el contenido de la documentación suministrada con los equipos.



Este símbolo se utiliza para advertir al usuario sobre la presencia de elementos con voltaje peligroso sin protección aislante, que puedan encontrarse dentro de la caja o alojamiento del producto, y que puedan representar riesgo de electrocución.

Precución

Leer las instrucciones • Leer y analizar todas las instrucciones de operación y seguridad, antes de usar el equipo.

Conservar las instrucciones • Conservar las instrucciones de seguridad para futura consulta.

Obedecer las advertencias • Todas las advertencias e instrucciones marcadadas en el equipo o en la documentación del usuario, deben ser obedecidas.

Evitar el uso de accesorios • No usar herramientas o accesorios que no sean específicamente recomendados por el fabricante, ya que podrían implicar riesgos.

Warning

Power sources • This equipment should be operated only from the power source indicated on the product. This equipment is intended to be used with a main power system with a grounded (neutral) conductor. The third (grounding) pin is a safety feature, do not attempt to bypass or disable it.

Power disconnection • To remove power from the equipment safely, remove all power cords from the rear of the equipment, or the desktop power module (if detachable), or from the power source receptacle (wall plug).

Power cord protection • Power cords should be routed so that they are not likely to be stepped on or pinched by items placed upon or against them.

Servicing • Refer all servicing to qualified service personnel. There are no user-serviceable parts inside. To prevent the risk of shock, do not attempt to service this equipment yourself because opening or removing covers may expose you to dangerous voltage or other hazards.

Slots and openings • If the equipment has slots or holes in the enclosure, these are provided to prevent overheating of sensitive components inside. These openings must never be blocked by other objects.

Lithium battery • There is a danger of explosion if battery is incorrectly replaced. Replace it only with the same or equivalent type recommended by the manufacturer. Dispose of used batteries according to the manufacturer's instructions.

Avvertimento

Alimentazione • Non fare funzionare ce matériel qu'avec la source d'alimentation indiquées sur l'appareil. Ce matériel doit être utilisé avec une alimentation principale comportant un fil de terre (neutre). Le troisième contact (de mise à la terre) constitue un dispositif de sécurité: n'essayez pas de la contourner ni de la désactiver.

Déconnexion de l'alimentation • Pour mettre le matériel hors tension sans danger, déconnectez tous les cordons d'alimentation de l'arrière de l'appareil ou du module d'alimentation de bureau (s'il est amovible) ou encore de la prise secteur.

Protection du cordon d'alimentation • Achémener les cordons d'alimentation de manière à ce que personne ne risque de marcher dessus et à ce qu'ils ne soient pas écrasés ou pincés par des objets.

Réparation-maintenance • Faire exécuter toutes les interventions de réparation-maintenance par un technicien qualifié. Aucun des éléments internes ne peut être réparé par l'utilisateur. Afin d'éviter tout danger d'électrocution, l'utilisateur ne doit pas essayer de procéder lui-même à ces opérations car l'ouverture ou le retrait des couvercles risquent de l'exposer à de hautes tensions et autres dangers.

Fentes et orifices • Si le boîtier de l'appareil comporte des fentes ou des orifices, ceux-ci servent à empêcher les composants internes sensibles de surchauffer. Ces ouvertures ne doivent jamais être bloquées par des objets.

Lithium Batterie • Il a danger d'explosion s'il y a un remplacement incorrect de la batterie. Remplacer uniquement avec une batterie du même type ou d'un équivalent recommandé par le constructeur. Mettre au rebut les batteries usagées conformément aux instructions du fabricant.

Vorsicht

Stromquellen • Dieses Gerät sollte nur über die auf dem Produkt angegebene Stromquelle betrieben werden. Dieses Gerät wurde für eine Verwendung mit einer Hauptstromleitung mit einem geerdeten (neutralen) Leiter konzipiert. Der dritte Kontakt ist für einen Erdschluß, und stellt eine Sicherheitsfunktion dar. Diese sollte nicht umgangen oder außer Betrieb gesetzt werden.

Stromunterbrechung • Um das Gerät auf sichere Weise vom Netz zu trennen, sollten Sie alle Netzkabel aus der Rückseite des Gerätes, aus der externen Stromversorgung (falls dies möglich ist) oder aus der Wandsteckdose ziehen.

Schutz des Netzkabels • Netzkabel sollten stets so verlegt werden, daß sie nicht im Weg liegen und niemand darauf treten kann oder Objekte darauf- oder unmittelbar dagegen gestellt werden können.

Wartung • Alle Wartungsmaßnahmen sollten nur von qualifiziertem Servicepersonal durchgeführt werden. Die internen Komponenten des Gerätes sind wartungsfrei. Zur Vermeidung eines elektrischen Schocks versuchen Sie in keinem Fall, dieses Gerät selbst öffnen, da beim Entfernen der Abdeckungen die Gefahr eines elektrischen Schlags und/oder anderer Gefahren bestehen.

Schlitze und Öffnungen • Wenn das Gerät Schlitze oder Löcher im Gehäuse aufweist, dienen diese zur Vermeidung einer Überhitzung der empfindlichen Teile im Inneren. Diese Öffnungen dürfen niemals von anderen Objekten blockiert werden.

Lithium-Batterie • Explosionsgefahr, falls die Batterie nicht richtig ersetzt wird. Ersetzen Sie verbrauchte Batterien nur durch den gleichen oder einen vergleichbaren Batterietyp, der auch vom Hersteller empfohlen wird. Entsorgen Sie verbrauchte Batterien bitte gemäß den Herstelleranweisungen.

Advertencia

Alimentación eléctrica • Este equipo debe conectarse únicamente a la fuente/tipo de alimentación eléctrica indicada en el mismo. La alimentación eléctrica de este equipo debe provenir de un sistema de distribución general con conductor neutro a tierra. La tercera pata (puesta a tierra) es una medida de seguridad, no puentearla ni eliminarla.

Desconexión de alimentación eléctrica • Para desconectar con seguridad la conectada de alimentación eléctrica al equipo, desenchufar todos los cables de alimentación en el panel trasero del equipo, o desenchufar el módulo de alimentación (si fuera independiente), o desenchufar el cable del receptáculo de la pared.

Protección del cables de alimentación • Los cables de alimentación eléctrica se deben instalar en lugares donde no sean pisados ni apretados por objetos que se puedan apoyar sobre ellos.

Reparaciones/mantenimiento • Solicitar siempre los servicios técnicos de personal calificado. En el interior no hay partes a las que el usuario debe acceder. Para evitar riesgo de electrocución, no intentar personalmente la reparación/mantenimiento de este equipo, ya que al abrir o extraer las tapas puede quedar expuesto a voltajes peligrosos u otros riesgos.

Ranuras y aberturas • Si el equipo posee ranuras o orificios en su caja/alojamiento, es para evitar el sobrecalentamiento de componentes internos sensibles. Estas aberturas nunca se deben obstruir con otros objetos.

Batería de litio • Existe riesgo de explosión si esta batería se coloca en la posición incorrecta. Cambiar esta batería únicamente con el mismo tipo (o su equivalente) recomendado por el fabricante. Desachar las baterías usadas siguiendo las instrucciones del fabricante.

Precautions, con't

安全须知 • 中文



这个符号提示用户该设备用户手册中有重要的操作和维护说明。



这个符号警告用户该设备机壳内有暴露的危险电压，有触电危险。

注意

阅读说明书 • 用户使用该设备前必须阅读并理解所有安全和使用说明。

保存说明书 • 用户应保存安全说明书以备将来使用。

遵守警告 • 用户应遵守产品和用户指南上的所有安全和操作说明。

避免追加 • 不要使用该产品厂商没有推荐的工具或追加设备，以避免危险。

警告

电源 • 该设备只能使用产品上标明的电源。设备必须使用有地线的供电系统供电。第三条线（地线）是安全设施，不能不用或跳过。

拔掉电源 • 为安全地从设备拔掉电源，请拔掉所有设备后或桌面电源的电源线，或任何接到市电系统的电源线。

电源线保护 • 妥善布线，避免被踩踏，或重物挤压。

维护 • 所有维修必须由认证的维修人员进行。设备内部没有用户可以更换的零件。为避免出现触电危险不要自己试图打开设备盖子维修该设备。

通风孔 • 有些设备机壳上有通风槽或孔，它们是用来防止机内敏感元件过热。不要用任何东西挡住通风孔。

锂电池 • 不正确的更换电池会有爆炸的危险。必须使用与厂家推荐的相同或相近型号的电池。按照生产厂的建议处理废弃电池。

FCC Class A Notice

This equipment has been tested and found to comply with the limits for a Class A digital device, pursuant to part 15 of the FCC Rules. Front Panel Operation is subject to the following two conditions: (1) this device may not cause harmful interference, and (2) this device must accept any interference received, including interference that may cause undesired operation. The Class A limits are designed to provide reasonable protection against harmful interference when the equipment is operated in a commercial environment. This equipment generates, uses, and can radiate radio frequency energy and, if not installed and used in accordance with the instruction manual, may cause harmful interference to radio communications. Front Panel Operation of this equipment in a residential area is likely to cause harmful interference, in which case the user will be required to correct the interference at his own expense.

NOTE

This unit was tested with shielded cables on the peripheral devices. Shielded cables must be used with the unit to ensure compliance with FCC emissions limits.

Table of Contents

Chapter One • Introduction and Installation	1-1
About this Guide.....	1-2
Options and accessories.....	1-2
Mounting the Scaler.....	1-2
Application diagram.....	1-3
Cabling the scaler.....	1-4
Optimizing the System for a DVD Player.....	1-4
Chapter Two • Front Panel Operation	2-1
Front Panel Controls and Indicators	2-2
Input selection buttons.....	2-2
Menu access.....	2-2
LCD menu display and controls.....	2-2
Menus, Configuration, and Adjustments	2-3
Menu overview.....	2-3
Main Menus.....	2-4
Picture control.....	2-5
Brightness and contrast.....	2-5
Color and tint.....	2-5
Horizontal and vertical centering.....	2-5
Horizontal and vertical sizing.....	2-5
Detail.....	2-5
Output Configuration.....	2-6
Resolution and refresh rates.....	2-6
Sync polarity.....	2-6
H format.....	2-6
Advanced configuration.....	2-7
Top and bottom blanking.....	2-7
Blue mode.....	2-7
Autoswitch (Autosw) mode.....	2-7
2:2 Pulldown detection (PAL film mode).....	2-7
Exit menu.....	2-8
Input Reset.....	2-8
System Reset.....	2-8
Front Panel Security Lockout (Executive Mode).....	2-8
Troubleshooting.....	2-9
IR 901 Infrared Remote Control.....	2-10

Table of Contents, cont'd

Chapter Three • Switcher Software	3-1
Appendix • Reference, Parts and Accessories	A-1
Specifications	A-2
Part Numbers and Accessories	A-2
Included parts	A-2
Accessories	A-2
Firmware Upgrade Installation	A-3

All trademarks mentioned in this manual are the properties of their respective owners.

68-1205-50 Rev. A
09 08



1

Chapter One

Introduction and Installation

About this Guide

Options and accessories

Mounting the Scaler

Application diagram

Cabling the Scaler

Optimizing the System for a DVD

Introduction and Installation

About this Guide

This setup guide describes how to quickly install, configure, and operate the Extron IN1502 digital two input video scaler and how to operate the optional IR 901 infrared remote control.

Throughout this guide the terms "IN1502", "video scaler", and "scaler" are used interchangeably to refer to the IN1502 product.

Options and accessories

IN1502 optional equipment includes:

- **IR 901 remote control** — Extron's IR 901 (part #70-152-01) is an infrared remote control which replicates all of the front panel controls of the IN1502 except the Menu and Next buttons.
- **Rack shelf mounting kit** — The 1U high, half rack width IN1502 can be rack mounted using the universal rack shelf mounting kit RSU 129 (part #60-190-01) or the basic rack shelf mounting kit RSB 129 (part #60-604-01).
- **Accessories** — Refer to the Appendix, "Reference, Parts and Accessories".

Mounting the Scaler

Tabletop/desktop placement

For tabletop or desktop placement only, install the self-adhesive rubber feet/pads (provided) on the four corners of the bottom of the enclosure.

Rack mounting

NOTE *For Underwriters Laboratories (UL) guidelines pertaining to the safe installation of the IN1502 in a rack, see the IN1502 User's Manual located on the included CD ROM or at www.extron.com.*

If feet were installed on the bottom of the IN1502, remove them.

Place the IN1502 on one half of the 1U (one unit high, one unit wide) RSU 129 rack shelf (part #60-190-01). Refer to the illustration for rack mounting the IN1502.

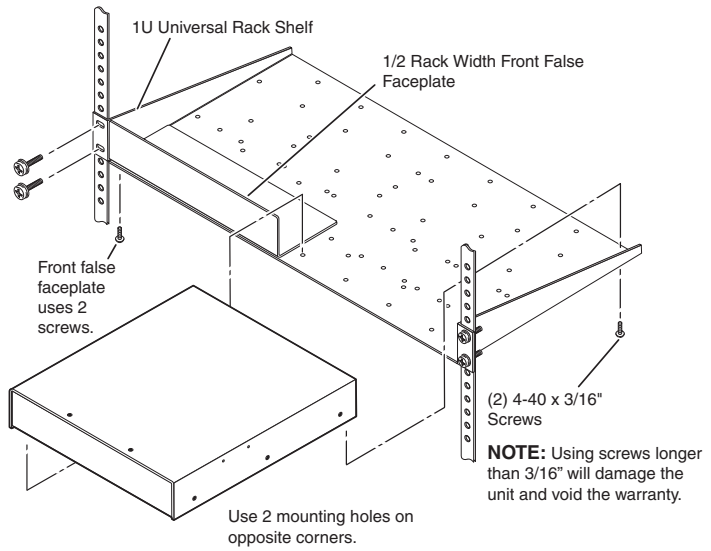

Rack mounting the IN1502

Application diagram

The diagram shown below is an example of a typical IN1502 application with cable connections.

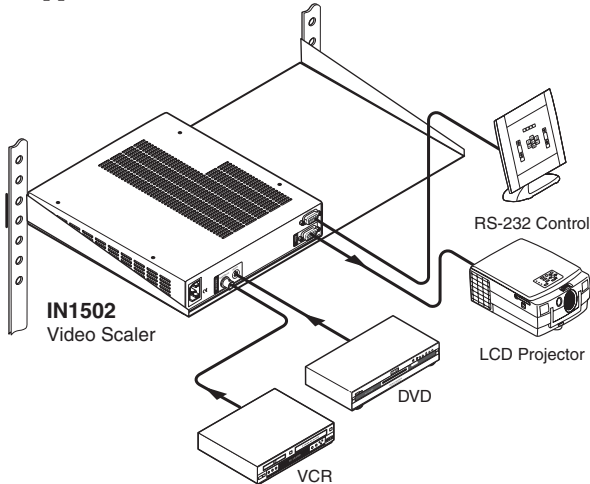

Application diagram example of the IN1502

Introduction and Installation

Cabling the scaler

Refer to the following diagram for connections to the IN1502.

Video input 1: Composite video
Connect a composite video signal to this female BNC connector.

Remote (RS-232/contact closure) 9-pin port
Provides two-way RS 232 communication and contact closure control.

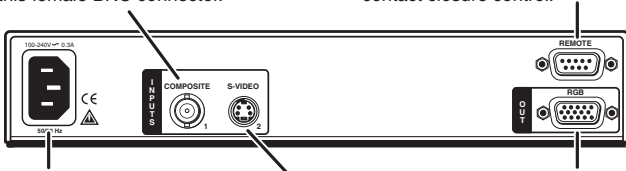

AC power connector
Plug a standard IEC power cord to a 100 to 240 VAC, 50 Hz or 60 Hz power source. The front panel LCD display and input selection LEDs light during power-up.

Video input 2: S-video
Connect an S-video signal to this 4-pin mini-DIN female connector.

RGB 15-pin HD video output
Connect an RGB video display.

IN1502 rear panel connectors

Optimizing the System for a DVD Player

To obtain optimal performance when using a DVD as a video source, Extron recommends the DVD player be set to output an aspect ratio of 16:9 and not 4:3. Since all DVDs are mastered as 16:9, if set up for 4:3 the player will internally scale and compress the signal. This will defeat the automatic 3:2 pulldown detection in the IN1502.

Sizing adjustments to correct aspect ratio should be done using the IN1502 controls.



Chapter Two

Front Panel Operation

Front Panel Controls and Indicators

Menus, Configuration, and Adjustments

Picture Control

Output Configuration

Advanced Configuration

Input & System Reset

Front Panel Security Lockout (Executive Mode)

IR 901 Infrared Remote Control

Troubleshooting

Front Panel Operation

Front Panel Controls and Indicators

The front panel of the IN1502 is shown below.

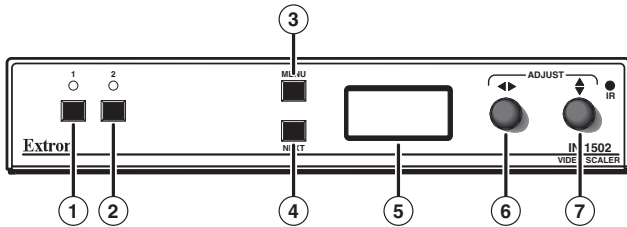

IN1502 front panel

Input selection buttons

NOTE *Input 1 accepts composite video only.
Input 2 accepts S-video only.*

- ① **Composite input button** — This button selects composite video Input 1. The LED lights green when the input is selected.
- ② **S-video input button** — This button selects S-video Input 2. The LED lights green when the input is selected.

Menu access

- ③ **Menu button** — Press this button to activate and scroll through the main menu system of the IN1502.
- ④ **Next button** — Press to scroll through the submenus of a selected main menu. Pressing the Next button during input configuration causes the current input number and format to be displayed on the LCD.

LCD menu display and controls

- ⑤ **LCD** — Displays configuration menus and status information.
- ⑥ **Adjust Horizontal (◀▶) knob** — In the submenu system, rotate this knob to change adjustment values, toggle settings or scroll through menu options.
- ⑦ **Adjust Vertical (⬆️⬆️) knob** — In the submenu system, rotate this knob to change adjustment values, toggle settings or scroll through menu options.

NOTE *The Adjust knobs have no mechanical limits to their rotation.*

Menus, Configuration, and Adjustments

Scaler configuration and adjustments are done using the front panel controls and menus displayed on the LCD screen, or by using the Simple Instruction Set (SIS™) commands via the RS-232 port. This setup guide provides installation and operating instructions using the front panel. Further details on software control can be found in the *IN1502 User's Manual* located on the included CD-ROM and at www.extron.com.

Menu overview

After the initial power up sequence, and when no adjustments are being made, the default display appears on the LCD screen. The screen cycles between the active input number and video format, and the output resolution and rate, as shown in the flowchart below.

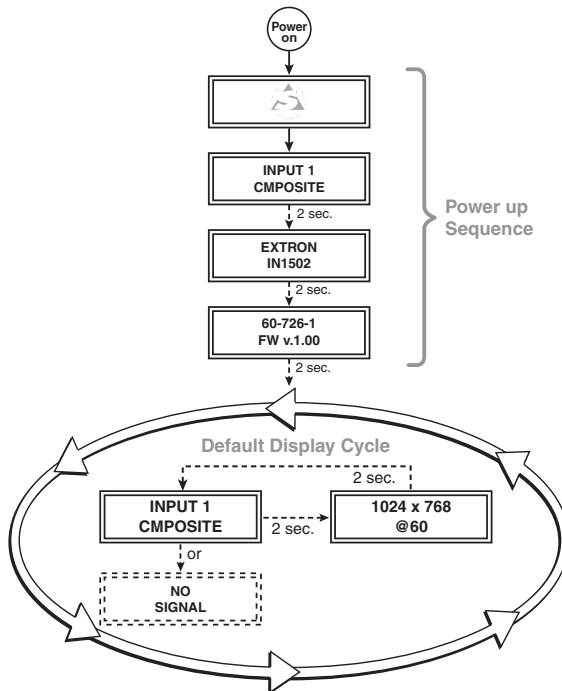

Default menus

NOTE The "No Signal" default display occurs if there is no signal present at the currently selected input.

NOTE From any menu or submenu, after ten seconds of inactivity the IN1502 saves all adjustments and switches to the default display cycle.

Front Panel Operation, cont'd

Main Menus

The main menus are shown in the following flowchart. Pressing the Menu button toggles through the main menus in the order shown. To enter submenus of a main menu, press Next.

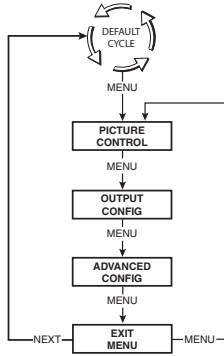

Main menus

NOTE To return to the default cycle, wait 10 seconds or press the Menu button until the Exit Menu appears, then press the Next button.

NOTE Submenus are accessed from a main menu by pressing the Next button. Regardless of which menu or submenu is active, any time the Main Menu button is pressed, the next main menu becomes active. For example, the menu changes from the Output Configuration menu or its submenus to the Advanced Configuration main menu.

Picture control

The following flowchart provides an overview of the Picture control submenu. Picture controls allow adjustment of each input for optimum picture quality of the output display. The picture controls are active for the input currently selected.

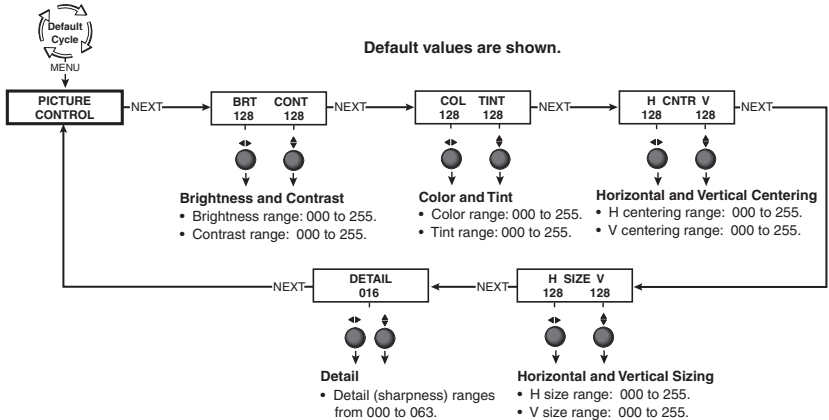

Picture Control submenus

Brightness and contrast

To adjust for maximum brightness and uniformity between the inputs without overdriving the output display, rotate the horizontal Adjust (◀▶) knob to adjust brightness and vertical Adjust (⬆️⬆️) knob to adjust contrast.

Color and tint

To adjust for proper color saturation and tint, and for uniformity between the inputs, rotate the horizontal Adjust (◀▶) knob to adjust color and the vertical Adjust (⬆️⬆️) knob to adjust tint.

Horizontal and vertical centering

To adjust horizontal and vertical centering of each input on the output display, rotate the horizontal Adjust (◀▶) knob and the vertical Adjust (⬆️⬆️) knob.

Horizontal and vertical sizing

Rotate the horizontal Adjust (◀▶) knob to adjust horizontal sizing and the vertical Adjust (⬆️⬆️) knob to adjust vertical sizing of each input on the output display.

Detail

Detail (sharpness) is used to compensate for long cable runs. Using either knob, adjust to restore fine detail of each input in the output display.

Front Panel Operation, cont'd

Output Configuration

The following flowchart provides an overview of the Output Configuration submenus and options for each setting.

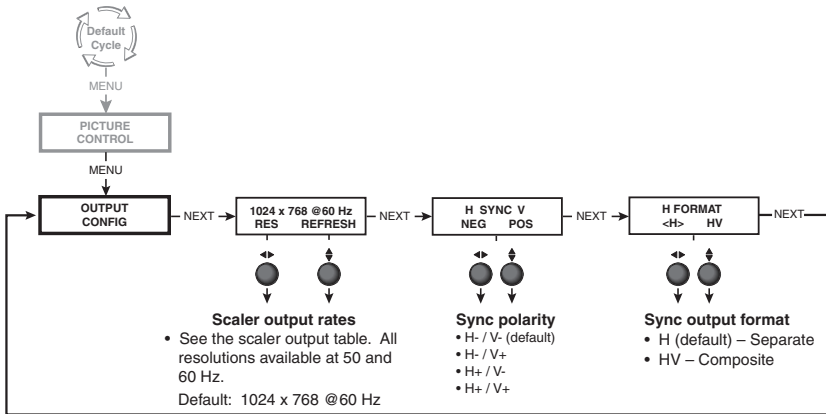

Resolution and refresh rates

Rotate the horizontal Adjust (◀▶) knob while in this submenu to select one of the available combinations of output resolution rates.

Rotate the vertical Adjust (⬆⬇) knob while in this submenu to select one of the available refresh (vertical scanning) rates.

Scaler Output Resolutions @ 50/60 Hz	
• 640 x 480	• 1024 x 768
• 800 x 600	• 1280 x 768
• 848 x 480	• 1360 x 765
• 852 x 480	• 1366 x 768

NOTE Default is 1024 x 768 @ 60Hz

Sync polarity

The display or projector may require a specific combination of horizontal (H) and vertical (V) sync signal polarities. Rotate either adjust knob to select the appropriate sync polarity combination.

H format

The display or projector may require separate horizontal and vertical sync or composite (combined horizontal and vertical) sync. Rotate either adjust knob to select "HV" for composite sync or "H" to output horizontal and vertical sync separately.

Advanced configuration

The following flowchart provides an overview of the Advanced Configuration submenus.

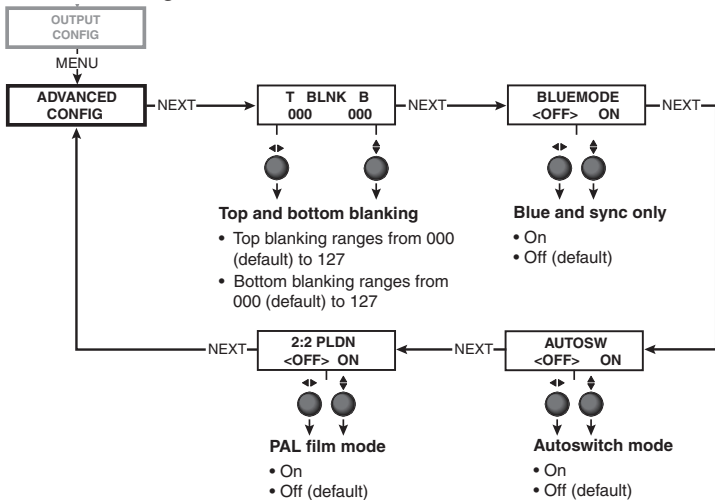

Advanced Configuration Submenus

Top and bottom blanking

During scaling, head switching artifacts or extraneous material such as closed captioning may cause noise at the top and/or bottom of the video. Blanking adds black lines to mask that noise. The inputs can have separate settings.

Rotate the Adjust (◀▶) knob to increase top blanking.

Rotate the Adjust (◈) knob to increase bottom blanking.

Blue mode

To aid in setup of color and tint, blue mode allows only sync and blue video signals from the selected input to the display.

Use either Adjust knob to toggle "On" or "Off".

Autoswitch (Autosw) mode

If both inputs have active signals, automatically selects Input 2.

Use either Adjust knob to toggle "On" or "Off".

2:2 Pulldown detection (PAL film mode)

Optimizes PAL video originating from film. For standard PAL video sources, such as cameras, set this feature to "Off" (default).

NOTE 3:2 pulldown detection is always on for NTSC video sources.

Use either Adjust knob to toggle "On" or "Off".

Front Panel Operation, cont'd

Exit menu

From this submenu, press the Next button to return to the default menu cycle, or press the Menu button to return to the picture control menu.

Input Reset

To reset each input of the IN1502 scaler to its default centering and sizing values, hold down the specific input button until the Input # Reset message is displayed on the LCD screen.

NOTE Autoswitch must be set to "OFF" before input reset can be used. See "Autoswitch (Autosw) mode".

System Reset

To reset the IN1502 to default values;

1. Remove AC power.
2. Press and hold the input 1 button while simultaneously plugging in the power cord.

The System Reset message is displayed on the LCD screen.

Front Panel Security Lockout (Executive Mode)

To prevent accidental changes to settings, executive mode locks all front panel functions except the input selection buttons. With executive mode active, all functions and adjustments can still be made through RS-232 control or with the optional IR 901 remote control. For details on RS-232 control, see chapter 3, "Serial Communication", of the *IN1502 User's Manual*.

Enable Executive Mode

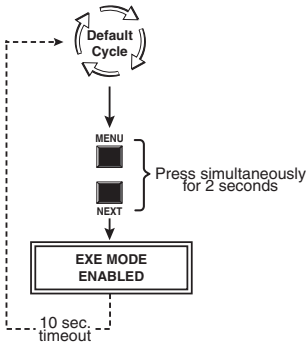

Disable Executive Mode

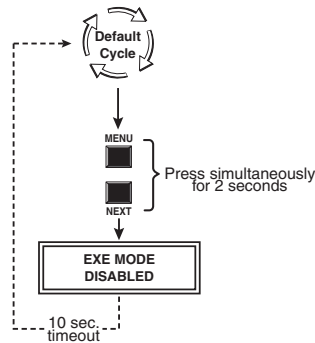

NOTE The input selection buttons (Input 1 and Input 2) remain functional during front panel lockout.

Troubleshooting

The following tips may assist troubleshooting.

1. Some symptoms may resemble others, so look through all examples before attempting to solve the problem.
2. Be prepared to backtrack in case the action does not solve the problem.
3. Keep notes and sketches in case the troubleshooting process gets lengthy. This also provides information if calling technical support.
4. Try simplifying the system by eliminating components that may have introduced the problem or made it more complicated.
5. **For sync-related problems:** Sync problems may result from using long cables or from improper termination. A sync adapter, such as an Extron ASTA (active sync termination adapter, part # **26-488-01**), may help solve these problems.
6. **For LCD and DLP projectors and plasma displays:** In addition to the sync-related information above, check the user manual that came with the projector for troubleshooting tips and for settings and adjustments.

The table below shows some common operating problems and solutions.

Problem	Cause	Solution
No image appears.	The input signal is incompatible.	Attach an input device that is compatible with NTSC 3.58, NTSC 4.43, PAL, or SECAM.
	Freeze mode was entered when the image was black.	Deactivate freeze mode.
	The scaled output rate is too high for the display.	Change the scaled output to a compatible resolution.
Image is frozen.	Freeze mode is on.	Deactivate freeze mode. Alternately, remove power from the scaler for a short time, then reconnect power..
Image is flashing.	The output rate is incorrect for the display.	Change the scaled output to a compatible resolution.
		Change the display resolution to match the scaled output.
The image is too soft.	The detail level needs to be changed.	Change the detail level.

Front Panel Operation, cont'd

IR 901 Infrared Remote Control

The IR 901 replicates all front panel controls except the Menu and Next buttons. If executive mode has been enabled, input selection and adjustments can still be made using the IR 901.

The IR 901 is shown. Buttons that are shown in gray are not functional.

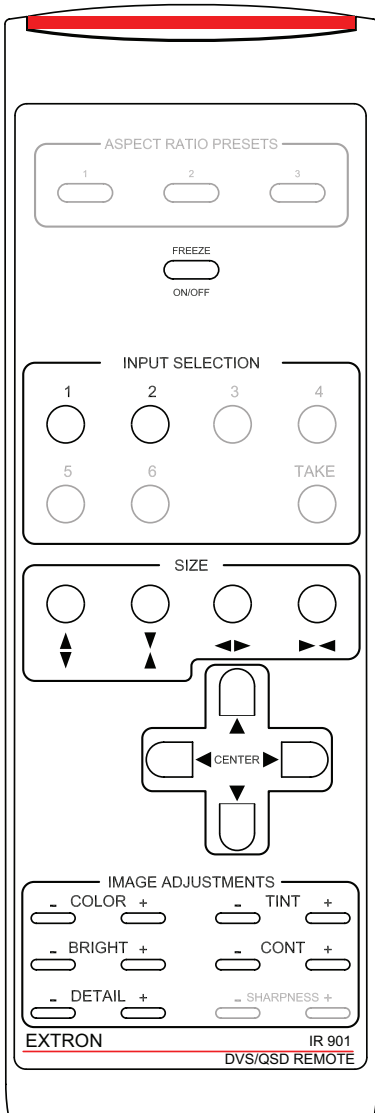

Freeze an input

To freeze the input being displayed, press the Freeze On/Off button. The video remains frozen until a different input is selected or the Freeze button is pressed again.

Select an input

To select an input source, press an input button (1 or 2).

Size and center

Use the Size and Center buttons to adjust the sizing and centering aspects of the displayed image.

Image adjustments

The color, tint, brightness, contrast, and detail of a displayed image may be adjusted by using the appropriate Image Adjustments button.



Chapter Three

Switcher Software

Remote Control port setup

Switcher Software

Remote control port setup

The IN1502 can be remotely controlled via a host computer or other device (such as a control system) attached to the rear panel RS-232 9-pin D female connector. RS-232 protocol for this connection is:

- 9600 baud
- 1 Stop bit
- no parity
- no flow control

The control device (host) can use the Extron Simple Instruction Set (SIS) commands. See Chapter 3 "Serial Communications", of the *IN1502 User's Manual* for complete information on serial control.

The serial connector also provides a way to select an input using a remote contact closure device. The connector has the following pin assignments:

Pin	RS-232 function	Description
1	-	No connection
2	Tx	Transmit data
3	Rx	Receive data
4	Input #1	Contact closure
5	Gnd	Signal ground
6	Input #2	Contact closure
7	-	No connection
8	-	No connection
9	Hardwired IR	IR input

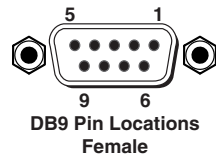

Contact closure control uses pins not used by the RS-232 interface. To select an input using a contact closure device, momentarily short the pin for the desired input to ground (pin 5). To force one of the inputs to always be selected, leave the short in place.

NOTE *The short overrides front panel input selections.*



A

Appendix

Reference, Parts and Accessories

Specifications

Part numbers and accessories

Firmware upgrade

Reference, Parts and Accessories

Specifications

For a complete set of specifications refer to the *IN1502 User's Manual*.

Part Numbers and Accessories

Included parts

These items are included in each order for a IN1502 scaler:

Description	Part number
IN1502	60-726-01
Rubber feet (self-adhesive) (4)	
IEC power cord	
Tweezer (small screwdriver)	
IN1502 User Manual (CD ROM)	68-1205-01
IN1502 Setup Guide	68-1205-50

Accessories

These items can be ordered separately:

Accessory	Part number
IR 901 remote control	70-152-01
1U Universal Rack Shelf Kit for 9.5" Deep Products, RSU 129	60-190-01
1U Basic Rack Shelf for 9.5" Deep Products, RSB 129	60-604-02
1U Under-Desk Mount Kit for 1/2 Rack Width, MBU 129	70-219-01

Please consult the *IN1502 User's Manual* found at **www.extron.com** or the included CD ROM for a complete list of optional accessories, pre-cut cables, connectors and bulk cable.

For highest quality and compatibility always use Extron pre-cut cable, connectors, and bulk cable.

Extron provides adapters for most common configurations required to connect audio, video and display devices to the BNC, S-video and VGA connectors of the IN1502. Consult the current Extron Product Catalog or **www.extron.com** for these adapters.

Firmware Upgrade Installation

In some cases the IN1502 firmware may require an update. The full procedure is included in the *IN1502 User's Manual*. It is recommended to return the unit to Extron for service and updates.

CAUTION *Changes to firmware must be performed by authorized service personnel only. Some IN1502 firmware updates must be done at the Extron factory.*

Reference, Parts and Accessories, cont'd

Extron's Warranty

Extron Electronics warrants this product against defects in materials and workmanship for a period of three years from the date of purchase. In the event of malfunction during the warranty period attributable directly to faulty workmanship and/or materials, Extron Electronics will, at its option, repair or replace said products or components, to whatever extent it shall deem necessary to restore said product to proper operating condition, provided that it is returned within the warranty period, with proof of purchase and description of malfunction to:

**USA, Canada, South America,
and Central America:**

Extron Electronics
1001 East Ball Road
Anaheim, CA 92805, USA

Asia:

Extron Electronics, Asia
135 Joo Seng Road, #04-01
PM Industrial Bldg.
Singapore 368363

**Europe, Africa, and the Middle
East:**

Extron Electronics, Europe
Beeldschermweg 6C
3821 AH Amersfoort
The Netherlands

Japan:

Extron Electronics, Japan
Kyodo Building,
16 Ichibancho
Chiyoda-ku, Tokyo 102-0082
Japan

This Limited Warranty does not apply if the fault has been caused by misuse, improper handling care, electrical or mechanical abuse, abnormal operating conditions or non-Extron authorized modification to the product.

If it has been determined that the product is defective, please call Extron and ask for an Applications Engineer at (714) 491-1500 (USA), 31.33.453.4040 (Europe), 65.6383.4400 (Asia), or 81.3.3511.7655 (Japan) to receive an RA# (Return Authorization number). This will begin the repair process as quickly as possible.

Units must be returned insured, with shipping charges prepaid. If not insured, you assume the risk of loss or damage during shipment. Returned units must include the serial number and a description of the problem, as well as the name of the person to contact in case there are any questions.

Extron Electronics makes no further warranties either expressed or implied with respect to the product and its quality, performance, merchantability, or fitness for any particular use. In no event will Extron Electronics be liable for direct, indirect, or consequential damages resulting from any defect in this product even if Extron Electronics has been advised of such damage.

Please note that laws vary from state to state and country to country, and that some provisions of this warranty may not apply to you.

Extron USA - West

Headquarters

+800.633.9876
Inside USA / Canada Only**+1.714.491.1500**
+1.714.491.1517 FAX**Extron USA - East****+800.633.9876**
Inside USA / Canada Only**+1.919.863.1794**
+1.919.863.1797 FAX**Extron EMEA****+800.3987.6673**
Inside Europe Only**+31.33.453.4040**
+31.33.453.4050 FAX**Extron Asia****+800.7339.8766**
Inside Asia Only**+65.6383.4400**
+65.6383.4664 FAX**Extron Japan****+81.3.3511.7655**
+81.3.3511.7656 FAX**Extron China****+400.883.1568**
Inside China Only**+86.21.3760.1568**
+86.21.3760.1566 FAX**Extron Middle East****+971.4.2991800**
+971.4.2991880 FAX