

FCMP 1010 • Installation Guide

IMPORTANT SAFETY INSTRUCTIONS

Read all instructions before starting installation.

When using this accessory, basic precautions should always be followed, including the following:

WARNING: Risk of Personal Injury. Maximum setup load for the FCMP 1010 is **200 lbs (91.6 kg)**. The structural ceiling must be capable of supporting 4 times the weight of the final setup.

SAVE THESE INSTRUCTIONS

NOTE: Refer to local building standards and codes to verify that the installation will meet the regulatory requirements. Observe all local and national building and safety codes, UL requirements, and ADA accessibility guidelines.

FCMP 1010 Flat Ceiling Mounting Plate

The FCMP 1010 is a simple and easily installed mounting solution for hanging a projector in installations where a long extension pole is used. The FCMP 1010 is available in black, can support a projector setup weighing up to 200 lbs (91.8 kg), and is suitable for installation on wooden joists and metal beams. It has an integral 1½" National Pipe Thread pipe adapter, allowing the attachment of a suitable projector pole, such as one of the Extron PMP (Projector Mounting Pole) series (See page 2 for list). The FCMP 1010 is a complementary mounting accessory for use with the Extron UPB 25 (Universal Projector Mount Bracket).

The features of the FCMP 1010 are shown in figure 1. Included in the kit are:

Flat Ceiling Mounting Plate, (1), and Hex Wrench, 3/32", (1).

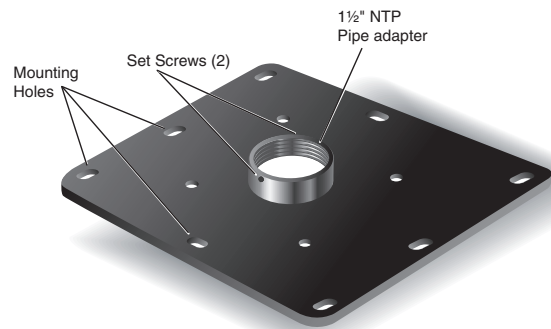

Figure 1 — FCMP 1010 Features

Checking the Mounting Location

Before starting the installation, it is important that these steps are followed:

- Check that the ceiling plate is suitable for the angle of the ceiling where the projector is to be installed.
- The installation must be done by a skilled technician

Installation

To install the FCMP 1010 on a flat ceiling

1. Locate a suitable wooden joist at the location chosen for the installation. Mark the position of the four corner mounting holes, or a minimum of one hole per side (see figure 1) in the center of a joist (minimum size 2 inch by 4 inch).
2. Drill pilot holes perpendicular to the joist. The pilot holes should be 70% of shank diameter and the full depth of the lag bolts to be used (1/4 inch diameter by 4 inch lag bolts are recommended).
3. Using fasteners suitable for the mounting surface (not supplied, see above for recommended type), firmly secure the FCMP 1010 to the joists. A minimum of four bolts, with washers, should be used.
4. Back out the set screws, and then screw a projector mounting pole (with an NPT 1.5 inch thread, such as an Extron PMP) of suitable length into the mounting plate. A minimum of three turns is needed to safely secure the pole. Be careful not to cross thread the pole into the mounting plate.
5. Secure the pole in position by tightening the set screws down.
6. Follow the instructions supplied with the projector mounting bracket to hang the bracket.

FCMP 1010 • Installation Guide, cont'd

Specifications

Mount type	Pole Mount
Material.....	Metal
Plate dimensions.....	Various (see image below)
Shipping weight	~ 3 lbs (1 kg)
Maximum capacity.....	200 lbs (92 kg)
Regulatory compliance	
Safety	CE, c-UL, UL for use with UL Listed mount and projector; OSHPD anchorage pre-approval
Vibration	ISTA 1A in carton (International Safe Transit Association)
Warranty	3 years parts and labor

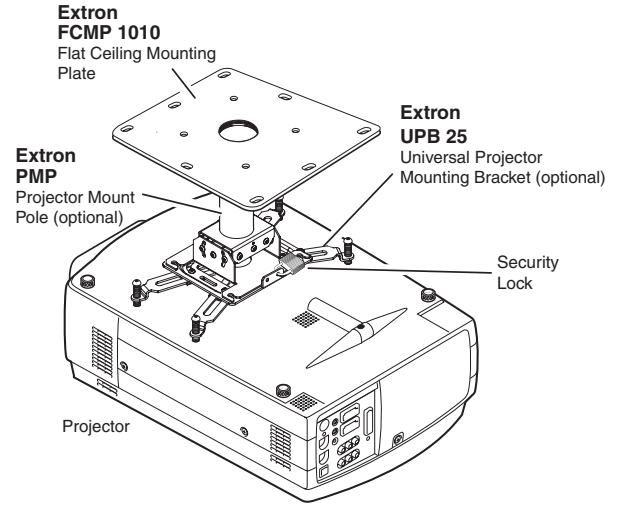

Figure 3. Typical Application of FCMP 1010

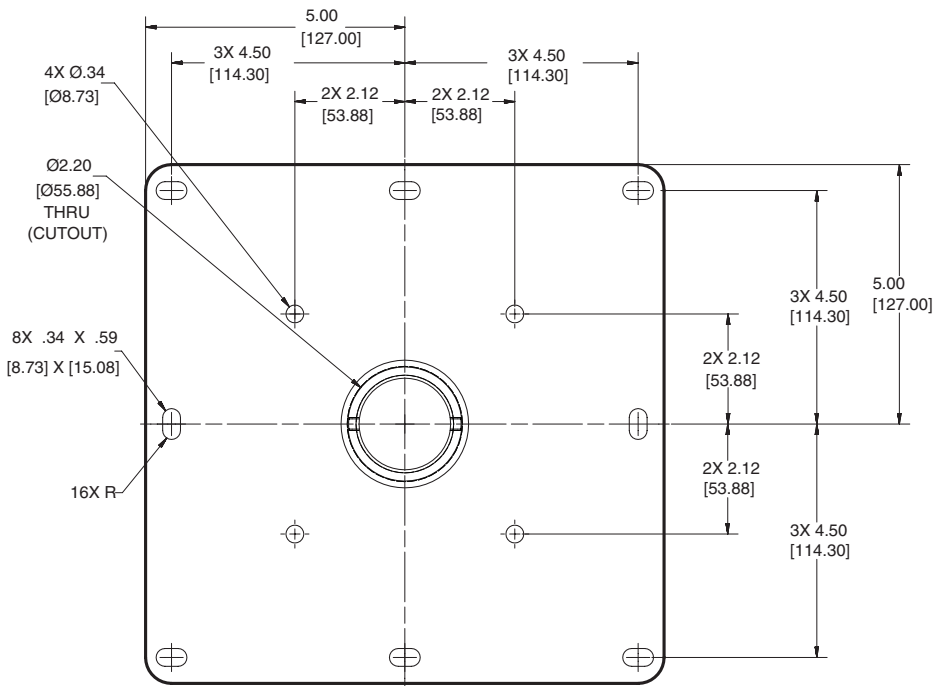

Figure 2. FCMP 1010 Dimensions

Extron Headquarters +1.800.633.9876 (Inside USA/Canada Only)	Extron Asia +65.6383.4400	Extron China +86.21.3760.1568	Extron Korea +82.2.3444.1571
Extron Europe +31.33.453.4040	Extron Japan +81.3.3511.7655	Extron Middle East +971.4.2991800	Extron India +91.80.3055.3777

68-1356-01
Rev B
08 12