

EBP 1200C Cable Cubby Enclosure with eBUS® Button Panel • Setup Guide

IMPORTANT:
Go to www.extron.com for the complete user guide and installation instructions before connecting the product to the power source.

The Extron EBP 1200C is a Cable Cubby® 1200 with an integrated eBUS button panel to combine convenient AV and data connectivity with a fully customizable AV system control interface for use with Extron IPCP Pro Series Control Processors.

NOTE: These products are only for use with Extron UL Listed IPCP Pro control processors.

This guide provides basic instructions for an experienced installer to install an EBP 1200C Cable Cubby button panel:

- [Setup Checklist](#)
- [Installing the EBP 1200C Cable Cubby](#)
- [Connecting to the eBUS System](#)

For more details on eBUS, see the *eBUS Technology Reference Guide*, available on www.extron.com. For details on configuration, see the software help files.

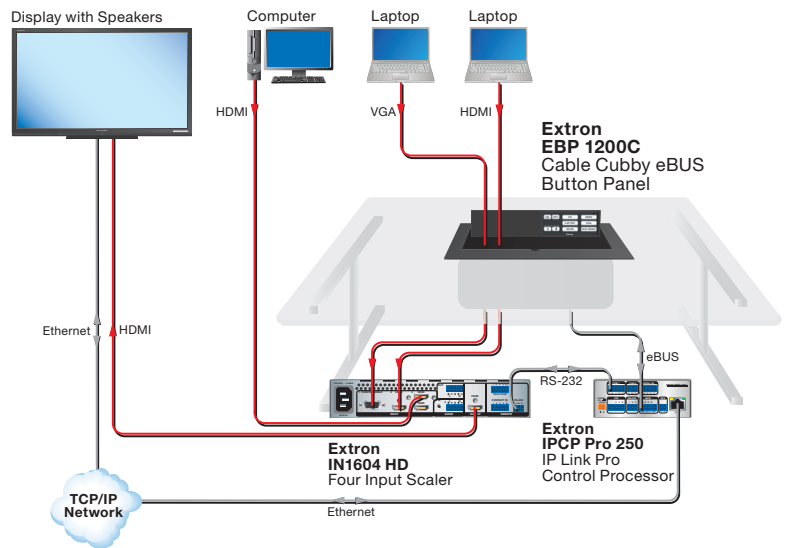

Figure 1. EBP 1200C Application Diagram

Setup Checklist

Step 1 – Planning

- Download and install the latest version of the software, firmware, and device drivers needed to configure the IPCP Pro and control the connected AV products. See the *IPCP Pro Series User Guide* (available at www.extron.com) for details on software and drivers.
- Obtain network information (IP addresses, passwords, DHCP settings, and the like) and the MAC address for the control processor.
- Obtain model names, drivers, and setup information for AV devices.
- Determine which eBUS cabling topologies to use and obtain cables, mounting hardware, and any power supplies or hubs required by that configuration.
- Make sure you are familiar with all the **Included parts** (see the next page) and have all the necessary tools for installing the Cable Cubby.
- Before cutting a hole in any furniture, select the best location for the EBP 1200C.
 - Ensure that the product is oriented so that the lid opens in the desired direction.
 - Ensure there is enough space for all the system cables and components, including cable retractors, if they are to be installed.
- Check all relevant regulations** (see the next page).

Step 2 – Cutting the Table

- Decide on the method for cutting a hole in the table (see [Cutting the Table](#) on page 3).
- Verify that you have the correct cut-out template and dimensions (see [Cutting the Table](#) on page 3).

Step 3 – Setting the eBUS ID Address

- All eBUS devices connected to the same control processor must have a unique eBUS ID address. This requires access to the DIP switches on the bottom panel of the EBP 1200C and it is more convenient to set the address before the EBP 1200C is installed in the table (see [Setting the eBUS ID Address](#) on page 10).

EBP 1200C • Setup Guide (Continued)

Step 4 – Mounting the EBP 1200C

Connectivity modules allow you to populate the Cable Cubby enclosure with a combination of AAP™ devices, cable pass-throughs, retractors, or power modules. The EBP 1200C accommodates your choice of any two modules, allowing you to customize the device to meet your specific needs.

The AAP module and cable pass-through module require some assembly before they can be installed in the EBP 1200C.

- Install the modules.
- Mount the EBP 1200C.
- Install the retractors.
- Route the cables.

Step 5 – Changing the Buttons

The EBP 1200C ships with a set of buttons installed and some additional blank buttons ship with the unit. You can order others from www.extron.com. To replace one or more of the individual buttons, see [Changing Buttons](#) on page 9

Step 6 – Connecting to the eBUS System

- Connect the EBP 1200C to an eBUS device or control processor.
- Configure the system.
- Test and troubleshoot.

Planning

Included parts

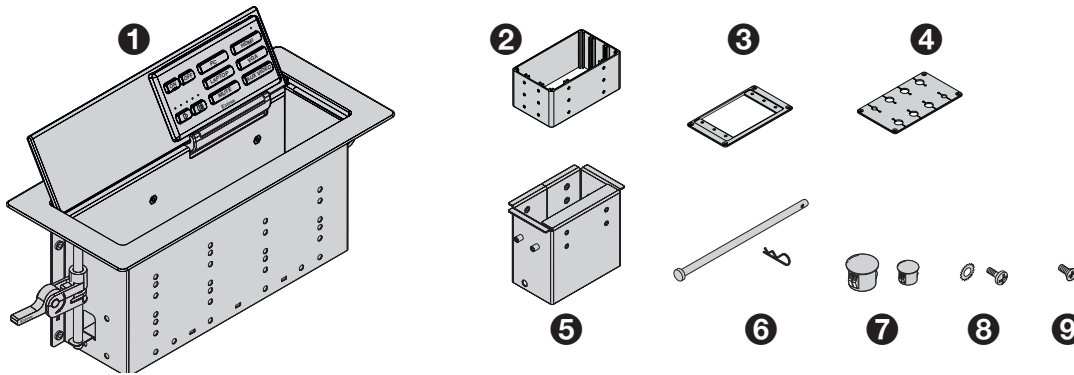

Item	Qty	Item	Qty	Item	Qty
1 EBP 1200C	1	6 Retractor Pin and Clip	1	9 #4-40 Module Screws	8
2 Connectivity Bracket	1*	7 Hole Plugs	6 (3/8") 2 (1/4")	Extron removal tool (not shown)	1
3 AAP Frame Plate	1			Extron Tweezer (not shown)	1
4 Cable Grommet Plate	1	8 #6 Pan-head Mounting Screws and Star Washers	8	Blank buttons (not shown)	1
5 Retractor Bracket	1				

NOTE: *A single connectivity bracket is provided. It can be used with either the AAP frame plate or the cable grommet plate.

Figure 2. EBP 1200C Included Parts

Check all relevant regulations

- Ensure the installation complies with local, state, and national building and electrical codes.
- Ensure the installation complies with the Americans with Disabilities Act or other accessibility requirements. When planning where to install these devices, you may need to consider factors affecting accessibility of the button panel such as height from the floor, distance from obstructions, and how far a user must reach to press the buttons.

For guidelines, see sections 307 (“Protruding Objects”) and 308 (“Reach Ranges”) of the 2010 ADA Standards for Accessible Design available at <http://www.ada.gov/regs2010/2010ADASTandards/2010ADASTandards.pdf>.

Installing the EBP 1200C Cable Cubby

Cutting the Table

CAUTION: Wear safety glasses when operating power equipment. Failure to comply can result in eye injury.

ATTENTION : Portez des lunettes de sécurité lorsque vous utilisez l'équipement électrique. Ne pas respecter cela peut conduire à une blessure à l'oeil.

ATTENTION:

- The opening in the table for the Cable Cubby should be cut only by licensed and bonded craftspeople. Exercise care to prevent scarring or damaging the furniture.
- L'ouverture dans la table pour le Cable Cubby devrait être coupée seulement par des artisans autorisés et qualifiés. Faites attention à ne pas faire de marques sur le meuble et à ne pas l'endommager.
- Follow all national and local building and electrical codes that apply to the installation site.
- Respectez tous les codes électriques et du bâtiment, nationaux et locaux, qui s'appliquent au site de l'installation.
- Use the appropriate metal Extron routing template or refer to the surface cutout dimensions before cutting a hole in the furniture or other surface. Pay special attention to the direction the unit will face. The connector access side is underlined (see CNC Wood Router below). Extron is not responsible for miscut mounting holes.
- Utilisez le gabarit de détournement métallique approprié ou reportez-vous aux dimensions de découpe de la surface indiquées ci-après avant de découper le meuble ou la surface. Faites particulièrement attention à la directions dans laquelle l'unité sera dirigée. Le côté pour accéder au connecteurs est souligné (voir CNC Wood Router ci-dessous). Extron ne sera pas responsable des erreurs de coupe.
- Ensure the table surface is at least 0.50 inch (1.27 cm) thick.
- Assurez vous que la surface de la table est au moins 1,27 cm (0,50 pouce) d'épaisseur.

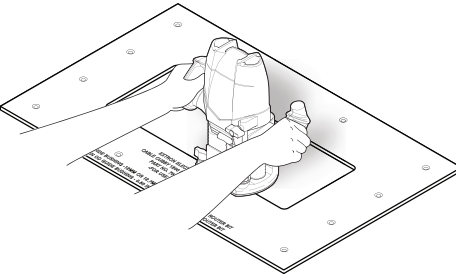
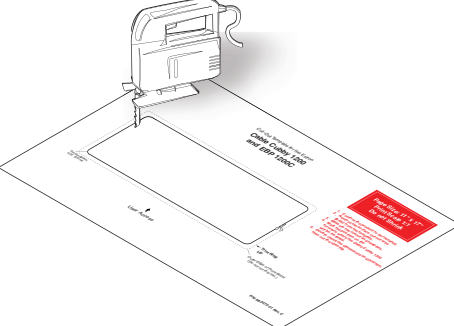
Hand Router and Routing Template	Jigsaw and Paper Cut-out Template	CNC Wood Router
		<p>If using a CNC wood router or other precise machinery, use the exact cut-out dimensions:</p> <p>User Access Width 10.00" (25.40 cm)</p> <p>Depth 4.00" (10.16 cm)</p>
<p>Visit www.extron.com for the EBP 1200C routing template part number and instructions.</p>	<p>The cut-out template and dimensions are available online at www.extron.com.</p>	

NOTE: The metal router guide must be purchased separately. It is reusable and should not be discarded when the installation is complete.

EBP 1200C • Setup Guide (Continued)

Mounting the EBP 1200C

A variety of modules allow you to populate the Cable Cubby enclosure with a combination of AAPs, cable pass-through, retractors, or power modules. The EBP 1200C accommodates your choice of any two modules, allowing you to customize the device to meet your specific needs.

Assemble the Connectivity Modules of your Choice

The EBP 1200C is provided with a single connectivity bracket that can be used with either the AAP frame plate or the cable grommet plate. Follow the steps below to assemble the connectivity modules of your choice before they can be mounted into the EBP 1200C.

AAP module

The AAP module accommodates up to three single-space AAPs.

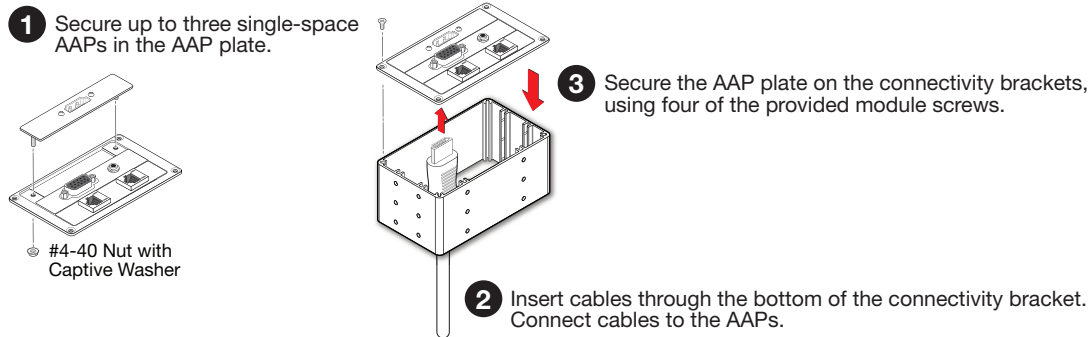

Figure 3. Assembling the AAP Module

NOTE: After assembling the AAP module, proceed to [Install the Modules](#) below.

Cable pass-through module

The cable pass-through module accommodates up to eight AV cables.

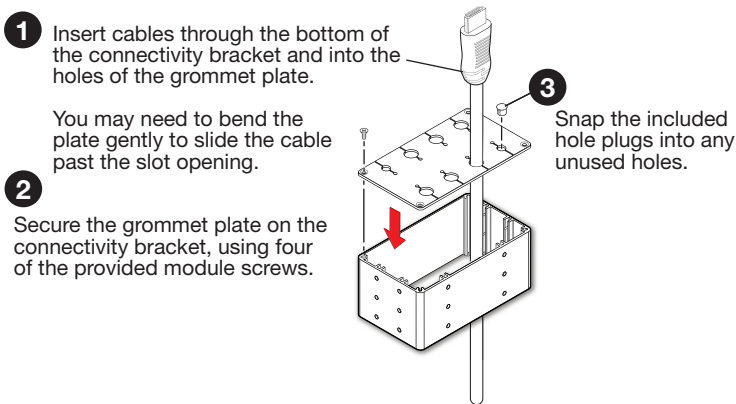

Figure 4. Assembling the Cable Pass-through Module

Install the Modules

Determine where the modules are installed in the Cable Cubby. Any combination of two modules can be installed. The modules can be installed on either side of the enclosure and at various heights.

NOTES:

- Ensure that there is enough room above the modules for the Cable Cubby lid to close completely.
- Use a screwdriver to secure the modules with the screws.

Retractor bracket

Use the retractor bracket to mount retractors in the Cable Cubby enclosure. The retractor bracket accommodates up to three Retractor Series/2 or Retractor Series/2 XL cable retraction modules. The retractors must be purchased separately.

If you require retractors, insert the retractor bracket as shown in figure 5.

NOTE: Do not mount the retractors in the retractor bracket until after the Cable Cubby is mounted (see [Install the Retractors](#) on page 7).

Install retractor filler modules (see www.extron.com) in any unused retractor mounting spaces.

Optional retractor brackets (see www.extron.com) each accommodate two cable retraction modules. These brackets must be purchased separately. They are sold in pairs and allow the cable retractors to be mounted at the outer edges of the enclosure with one of the other modules mounted centrally.

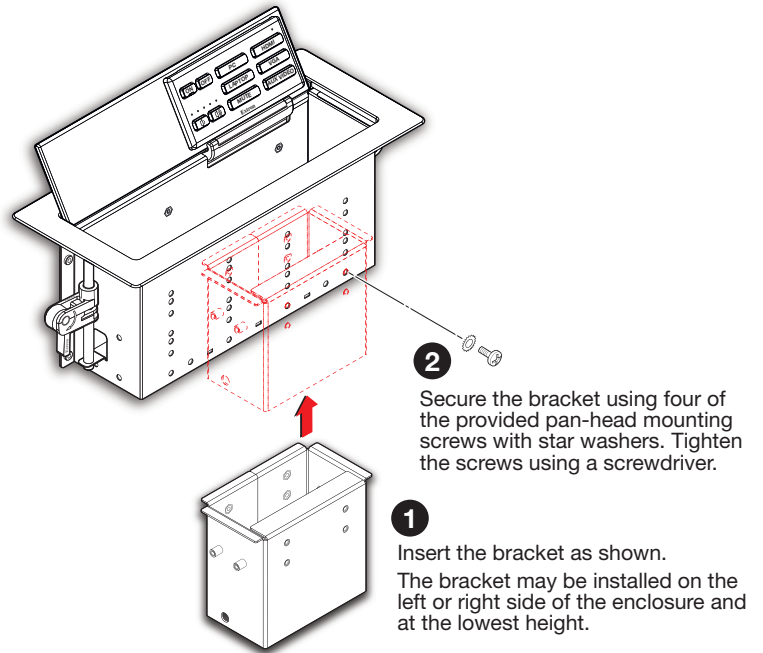

Figure 5. Install the Retractor Bracket

AAP module, cable pass-through module and power module

Insert the modules into the cable cubby as shown in figure 6.

NOTE: Extron recommends mounting the power module on the left side of the enclosure.

AC power and AC+USB power modules are available for US, Europe, and other major world markets. They must be purchased separately (see www.extron.com).

Most AC power modules provide two unswitched AC outlets.

The AC+USB power modules provide one or two AC outlets and two USB power outlets.

WARNING: Risk of Electric Shock. To ensure proper electrical grounding, use the provided #6-32 mounting screws with the star washers.

AVERTISSEMENT : Risque de choc électrique. Afin d'assurer une mise à la terre correcte, utilisez les fixations de mise à la terre #6-32 et les rondelles en étoile fournies.

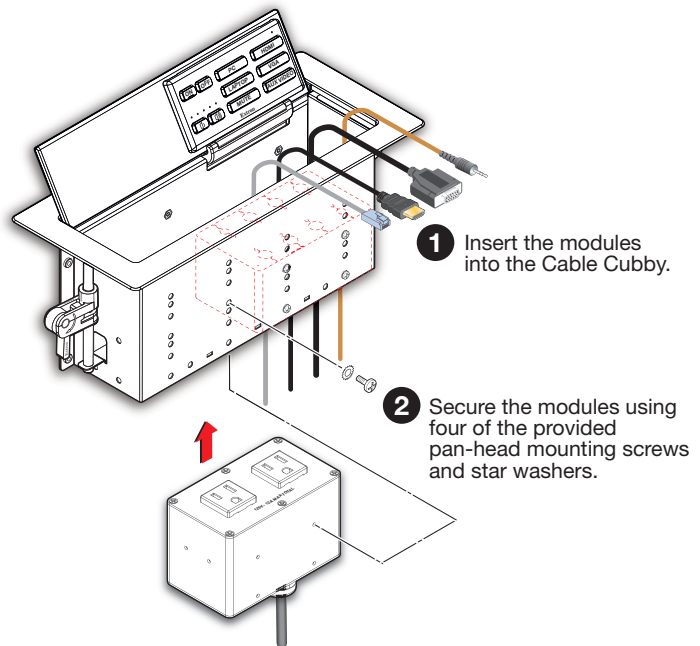

Figure 6. Install the Connectivity and Power Modules

EBP 1200C • Setup Guide (Continued)

Mount the EBP 1200C

TIP: Before mounting the EBP 1200C, you should set the eBUS ID address, since this requires access to the DIP switches, which are on the bottom of the unit (see [Setting the eBUS ID Address](#) on page 10).

Insert the EBP 1200C enclosure into the table

CAUTION: The flanged edges of the top of the surface enclosure are sharp. These edges are also soft and may be easily nicked or bent. Exercise caution when handling the enclosure to prevent personal injury or damage to the enclosure.

ATTENTION : Les extrémités à brides du haut de la surface du boîtier sont aiguisées. Ces extrémités sont aussi lisses et peuvent facilement être coupées ou pliées. Soyez prudents lorsque vous manipulez le boîtier afin d'éviter de l'endommager ou de vous blesser.

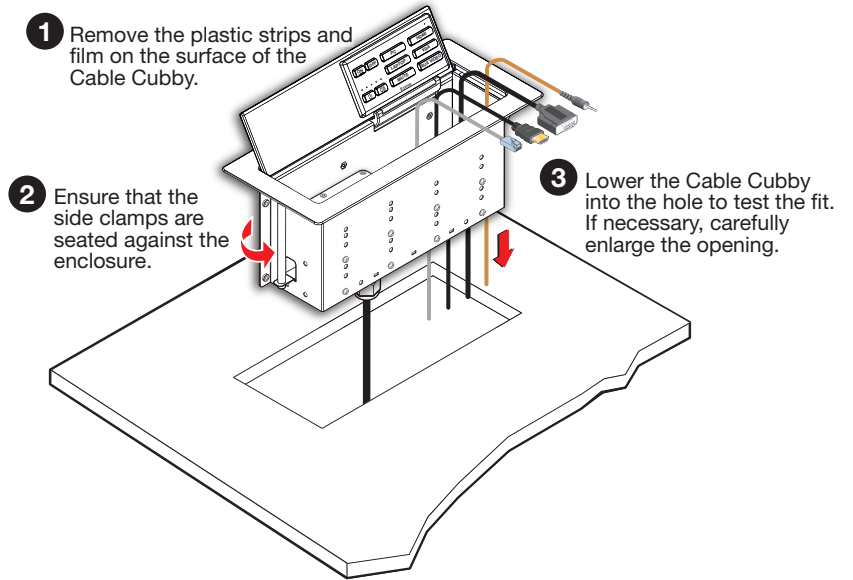

Figure 7. Insert EBP 1200C Enclosure into the Table

Under the Table, Adjust the Side Clamps on the Enclosure

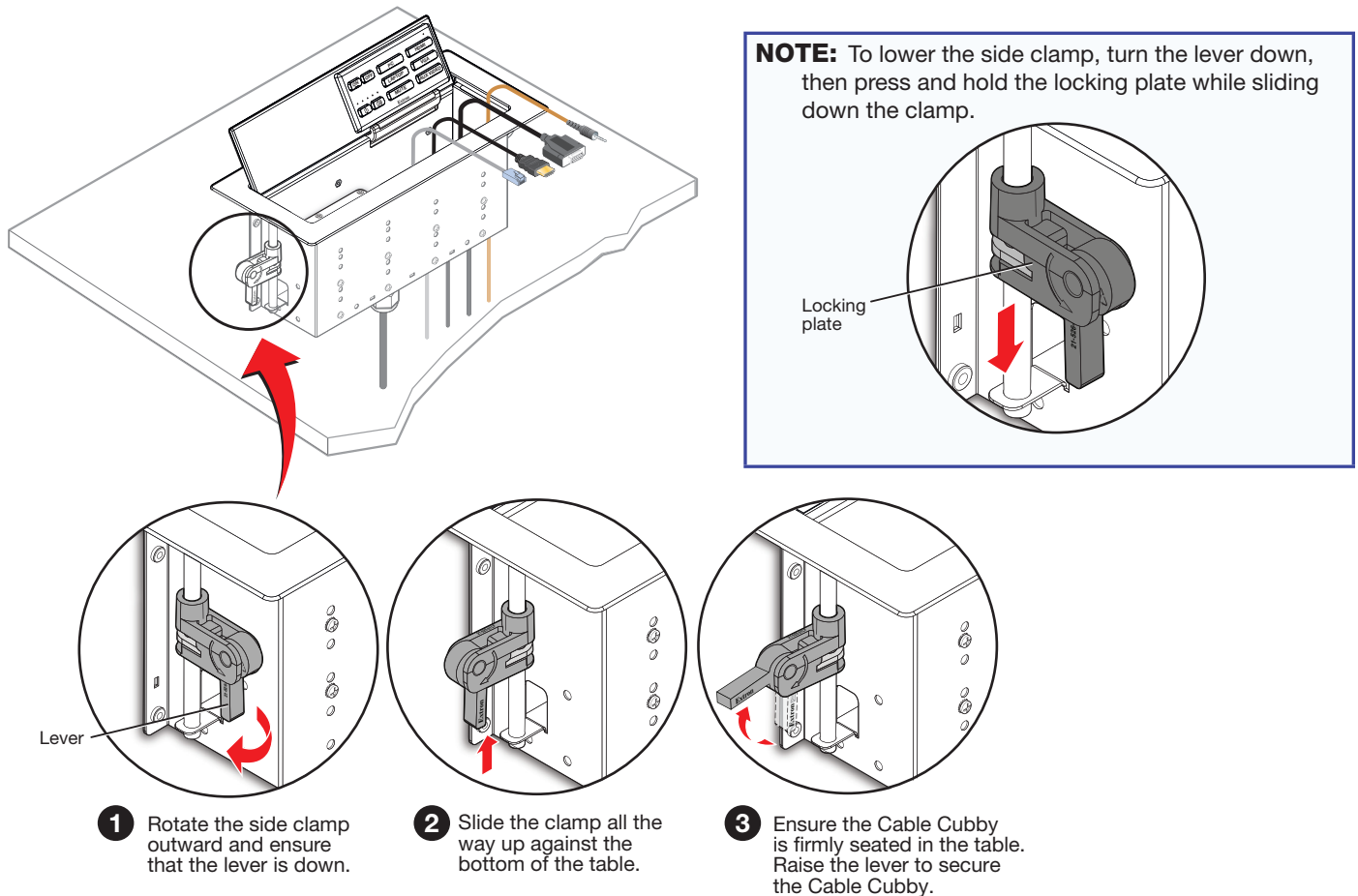

Figure 8. Secure the Cable Cubby Enclosure

Install the Retractors

Retractors can be installed in a vertical, angular, or horizontal orientation. No adjustment of the enclosure screws is needed if the retractors are mounted vertically. To mount at an angle or horizontally, adjust the enclosure screws as shown below. When the retractors are mounted horizontally, the retractor mechanism must be secured to the underside of the table (see *Cable Retractor Setup Guide*, which is available at www.extron.com).

To secure the retractors in the retractor bracket, follow the instructions in figure 9.

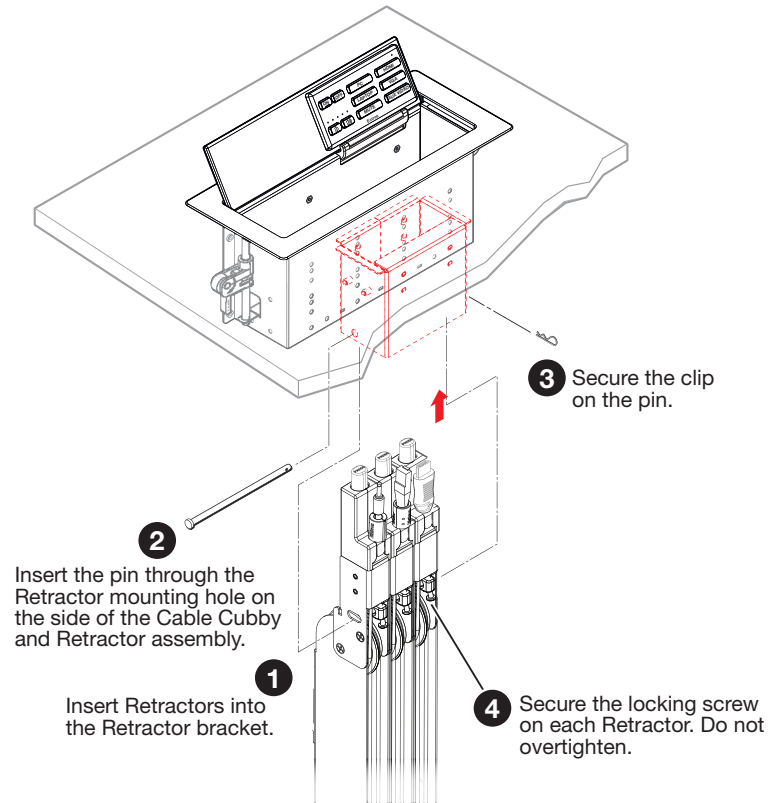
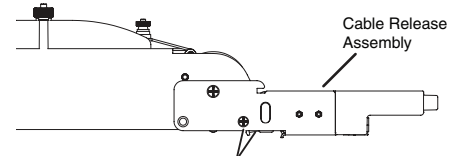

Figure 9. Installing Retractors

Horizontal Mounting



Remove two enclosure screws (one on each side) from this position. Then mount the Retractors as shown at left.

See the *Cable Retractor Setup Guide*, available at www.extron.com, for additional steps.

Angular Mounting

Remove the two enclosure screws, as shown above, and then follow this step:

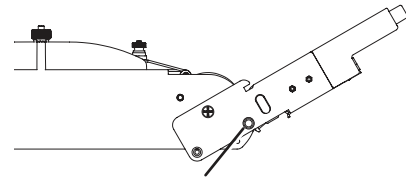

Move the cable release assembly upward until the angular mounting hole is visible. Reinstall the enclosure screws in this hole (both sides).

Route and Connect the Cables to Cable Cubby

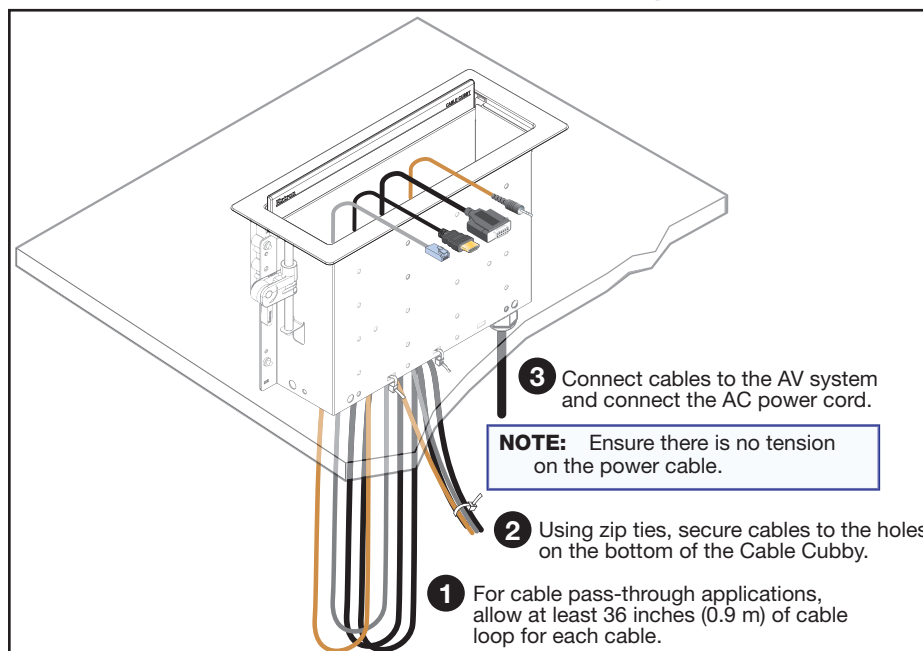

Figure 10. Route and Connect AV Cables

CAUTION: Risk of Electric Shock.
This equipment must be grounded.

ATTENTION : Risque de choc électrique. Cet équipement doit être fixé au sol.

EBP 1200C • Setup Guide (Continued)

Connecting to the eBUS System

The EBP 1200C has two eBUS ports that support power and communication with an IPCP Pro control processor. Up to eight eBUS endpoint devices such as EBP button panels can be connected to the control processor and to each other in various cabling topologies. These can include daisy chain, star, or hybrid system (a combination of both daisy chain and star) topologies (see the *eBUS Technology Reference Guide*, available on www.extron.com, for basic diagrams). Every endpoint device must have a unique identification address (bus ID) within the system.

Once the bus ID DIP switches are set on the EBPs, use Extron Global Configurator® (GC) Plus and Professional software, or Global Scriptor® programming, to configure the control processor. Once configured, the EBPs can control the AV system.

EBP Front Panel Features

NOTE: Use Global Configurator Plus and Professional to configure the EBP buttons and LEDs. Alternatively, use Global Scriptor to program the buttons and LEDs.

- A Cable Cubby lid** — Tilts back to 130°. Friction washers ensure the lid holds any angle set by the user.
A switch in the hinge activates the buttons when the lid is fully open and deactivates them when the lid is closed to prevent accidental button presses.
- B Power buttons** — Are labelled ON and OFF and control the power to the display device. The **ON** button has a nub that can be felt with the finger tips.
- C Volume LED meter** — Shows the volume level.
- D Volume buttons** — Can be used to increment or decrement audio volume. There is also a **MUTE** button to the right.
- E Button panel removal slots** — Use the Extron removal tool in these slots to release the top of the panel when replacing buttons.
- F Input and function buttons** — If these buttons are used to select an input, they can be configured as a group to act in a mutually exclusive manner. However, the buttons can also be configured to carry out separate functions. In that case, they can be removed from the input group and configured independently.
- G Transmit LED** — Blinks once when any button is pressed.
- H Button panel hinge** — Holds the bottom of the panel in place, allowing the panel to tilt forward when replacing buttons.

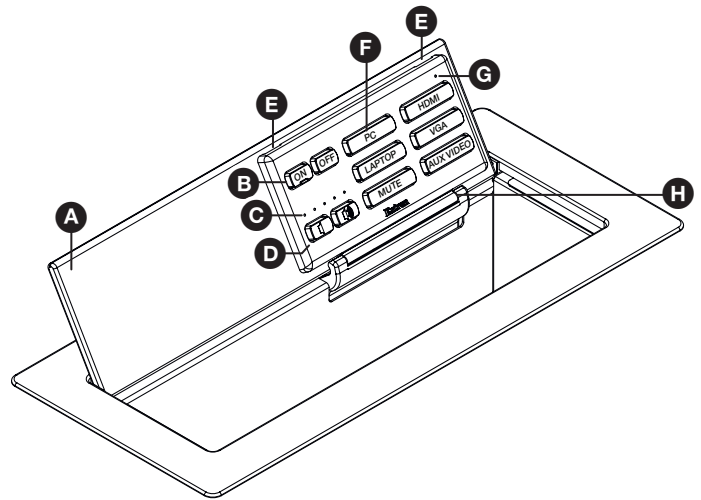

Figure 11. EBP 1200C Front Panel

EBP Bottom Panel

- A DIP switches** — Used to provide each unit connected to the same control processor with a unique bus ID (see [Setting the eBUS ID Address](#) on page 10).
- B eBUS connectors (2 blocks)** — These four-pole captive screw blocks connect the EBP 1200C to a controller and to other panels.
- C Status LEDs** — These three LEDs are mutually exclusive (only one LED lights at a time). When the unit is not receiving power, all three LEDs are off.
 - Link — lights green when power and communication with the control processor are both good.
 - Com Error — lights amber when there is no communication with the control processor.
 - ID Error — lights red when there is a bus ID conflict.
- D Reset button** — Resets the firmware to the factory installed version.
 1. Disconnect the eBUS cable that is providing power.
 2. Press and hold down the **Reset** button while reconnecting power. During the reset process, the front panel buttons are not lit and the eBUS Link Status LED is lit.

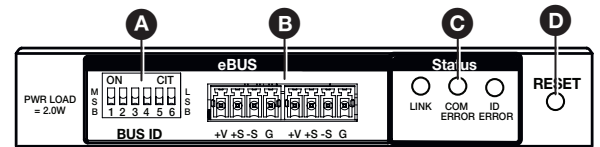
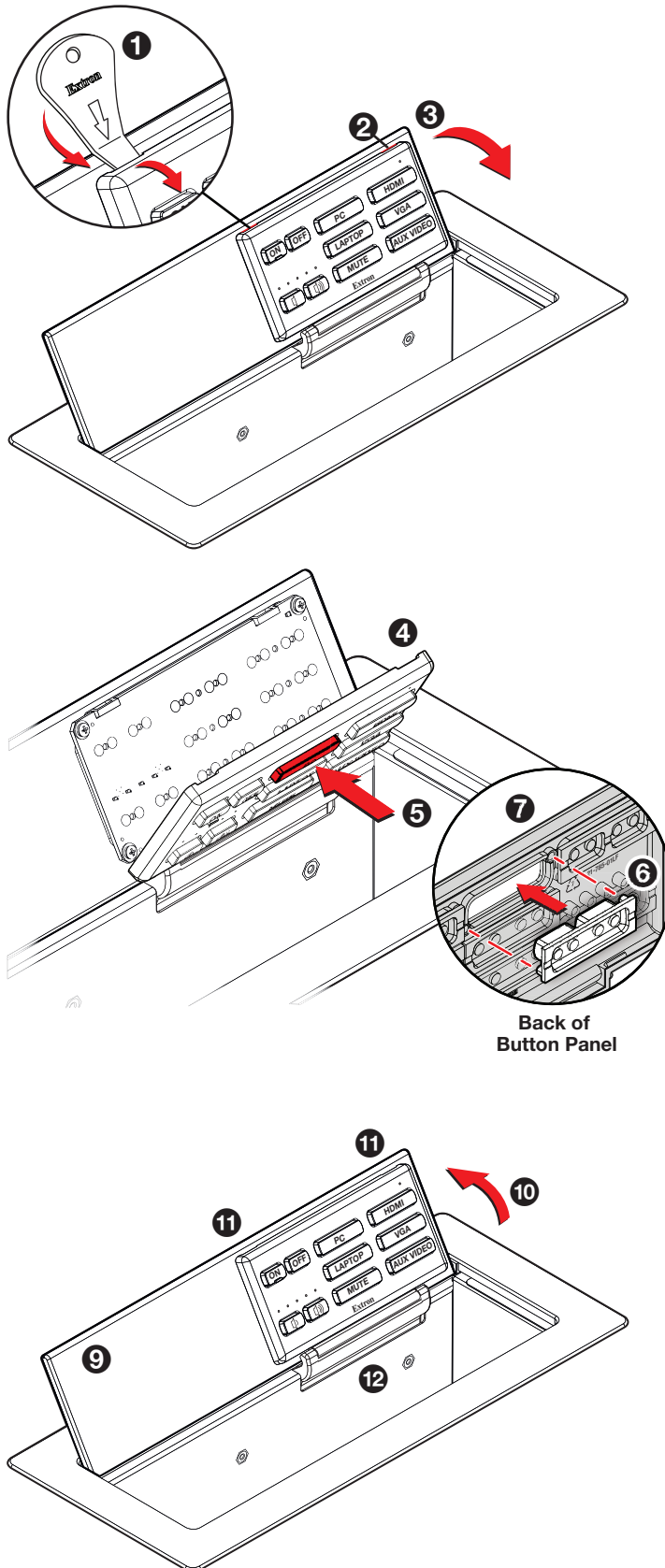

Figure 12. EBP 1200C Bottom Panel

After about 30 seconds, the front panel buttons are lit dimly and the unit firmware is restored to the original factory-installed version. For information about updating the unit firmware, see the *eBUS Technology Reference Guide*.

Changing Buttons

You can replace a faceplate or one or more of the individual buttons. Some additional blank buttons ship with the unit. You can order standard or custom buttons from www.extron.com. To change the buttons:



- 1 Insert the Extron removal tool into one of the removal slots in the top edge of the button panel. Carefully release the corner of the panel.
- 2 Repeat step 1 to release the opposite corner of the panel.
- 3 Tilt the lid forward to prevent the buttons from falling out.
- 4 Pull the top of the button panel forward. The panel is attached to the lid with a hinge that allows access to the buttons without the panel becoming completely detached. You can now return the lid to the fully open position.
- 5 From the front of the panel, press the button until it is free of the panel.
- 6 From the back of the button panel, insert the replacement button into the appropriate slot. Ensure the text is in the correct orientation. Align the two pegs on the button with the holes on the button panel.
- 7 Press the button into the faceplate until the pegs on the button are seated securely in the holes.
- 8 Repeat steps 5-7 for any other buttons that need to be replaced.
- 9 Tilt the lid forward to prevent the buttons from falling out.
- 10 Tilt the lid and the button panel backwards.
- 11 Press the top corners so that they snap back into place, securely attaching the button panel to the lid. If the corners do not snap back easily, you may need to adjust how the button panel is seated in the hinge attaching it to the lid (12).

Figure 13. Replacing Buttons

Setting the eBUS ID Address

Up to eight units can be connected to one control processor. Each unit connected to the same control processor must have a unique six-bit, binary eBUS ID (address), which is set with the DIP switch assembly on the bottom panel of the EBP 1200C (figure 14).

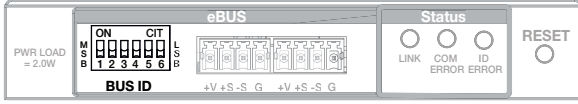

Figure 14. DIP Switches on EBP 1200C Bottom Panel

If other modules have the same bus ID, address conflicts may cause one or more of the panels to not be recognized by the IPCP Pro control processor.

Set the bus identification DIP switches for each EBP button panel in the system using the diagrams in this section as a guide.

NOTES:

- By factory default, the EBP 1200C is set to address 26 (binary: 011010), as shown in the diagram below.
- Any address can be used except address 0 (binary: 000000). This is reserved as the address of the controller and may not be used.
- Switch 1 (on the left) is the highest value (32, the most significant bit) and is labelled MSB.
- Switch 6 (on the right) is the lowest value (1, the least significant bit) and is labelled LSB.
- **Up = on = 1, Down = off = 0**

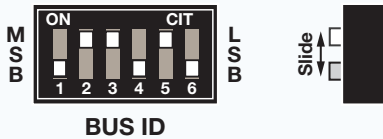

Example eBUS IDs		
Address	eBUS ID	DIP Switch
0	000000* *Reserved for controller address	
1	000001	
2	000010	
3	000011	
4	000100	
5	000101	
6	000110	
7	000111	
8	001000	

Cable All Devices

Attach cables using the diagrams in this section as a guide. Connect a 4-pole captive screw connector to each end of the cable, wiring both ends as shown in figure 15. In most cases the EBPs are powered by the IPCP Pro control processor that provides the eBUS signal. Power is carried on the V+ pin of each eBUS connection.

The four connectors are:

- **+V** — carries 12 VDC power from the controller, active hub, or power supply
- **+S** — carries the positive data signal
- **-S** — carries the negative data signal
- **G** — ground

Extron STP20-2/1000 or STP20-2P/1000 cable is recommended for eBUS connections.

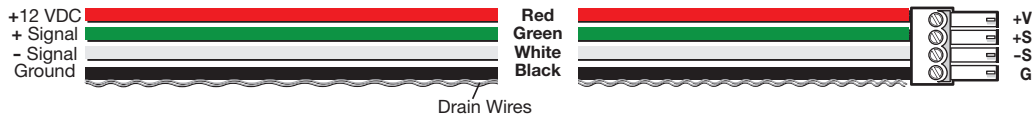

Figure 15. Basic eBUS Connector Wiring and Cable Color Code

For long cable runs, category cable can provide a convenient option for eBUS signals. For these applications, compatible 4-pole captive screw to RJ-45 adapters are available at www.extron.com.

Extron recommends using shielded CAT6 cable.

NOTES:

- The two eBUS blocks are interchangeable: either block can be used to connect the unit to a controller or EBDB and either can be used to daisy-chain the unit to another EBP.
- Connect up to eight eBUS endpoint devices for each IPCP Pro control processor.
- Wire the connectors in the same way at both ends.
- See the *eBUS Technical Reference Guide* (available at www.extron.com) for information about the maximum cable distance and power requirements for your eBUS system.
- Do NOT power an EBP from more than one power source.

ATTENTION:

- Always use a power supply supplied or specified by Extron. Use of an unauthorized power supply voids all regulatory compliance certification and may cause damage to the supply and the unit.
- Utilisez toujours une source d'alimentation fournie par Extron. L'utilisation d'une source d'alimentation non autorisée annule toute conformité réglementaire et peut endommager la source d'alimentation ainsi que l'unité.
- If not provided with a power supply, this product is intended to be supplied by a UL Listed power source marked "Class 2" or "LPS" and rated output 12 VDC, minimum 1.0 A.
- Si ce produit ne dispose pas de sa propre source d'alimentation électrique, il doit être alimenté par une source d'alimentation certifiée UL de classe 2 ou LPS et paramétré à 12 VDC et 1,0 A minimum.
- Unless otherwise stated, the AC/DC adapters are not suitable for use in air handling spaces or in wall cavities.
- Sauf mention contraire, les adaptateurs AC/DC ne sont pas appropriés pour une utilisation dans les espaces d'aération ou dans les cavités murales.
- The installation must always be in accordance with the applicable provisions of National Electrical Code ANSI/NFPA 70, article 725 and the Canadian Electrical Code part 1, section 16. The power supply shall not be permanently fixed to building structure or similar structure.
- Cette installation doit toujours être en accord avec les mesures qui s'applique au National Electrical Code ANSI/NFPA 70, article 725, et au Canadian Electrical Code, partie 1, section 16. La source d'alimentation ne devra pas être fixée de façon permanente à une structure de bâtiment ou à une structure similaire.

EBP 1200C • Setup Guide (Continued)

EBPs that are relatively far from the control processor (see the *eBUS Technology Reference Guide* on www.extron.com for details) can be connected to an optional Extron PS 1220EB eBUS power inserter, or an Extron 12 VDC desktop power supply as shown in the following diagrams.

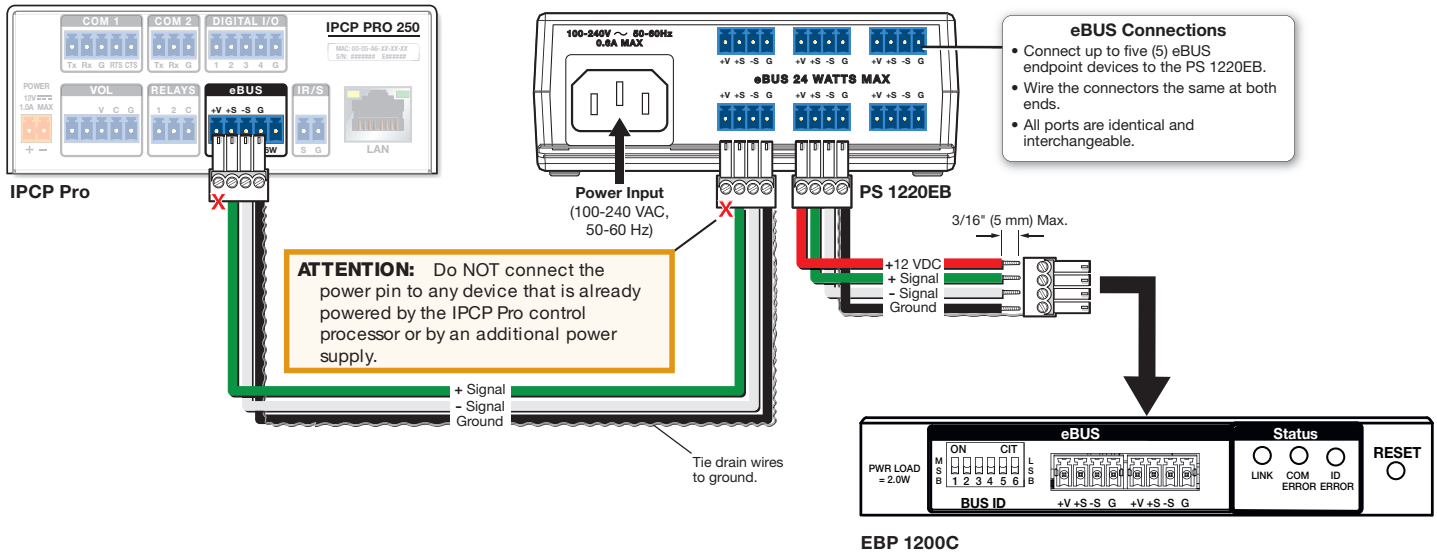

Figure 16. Powering an eBUS System with an PS 1220EB Power Inserter

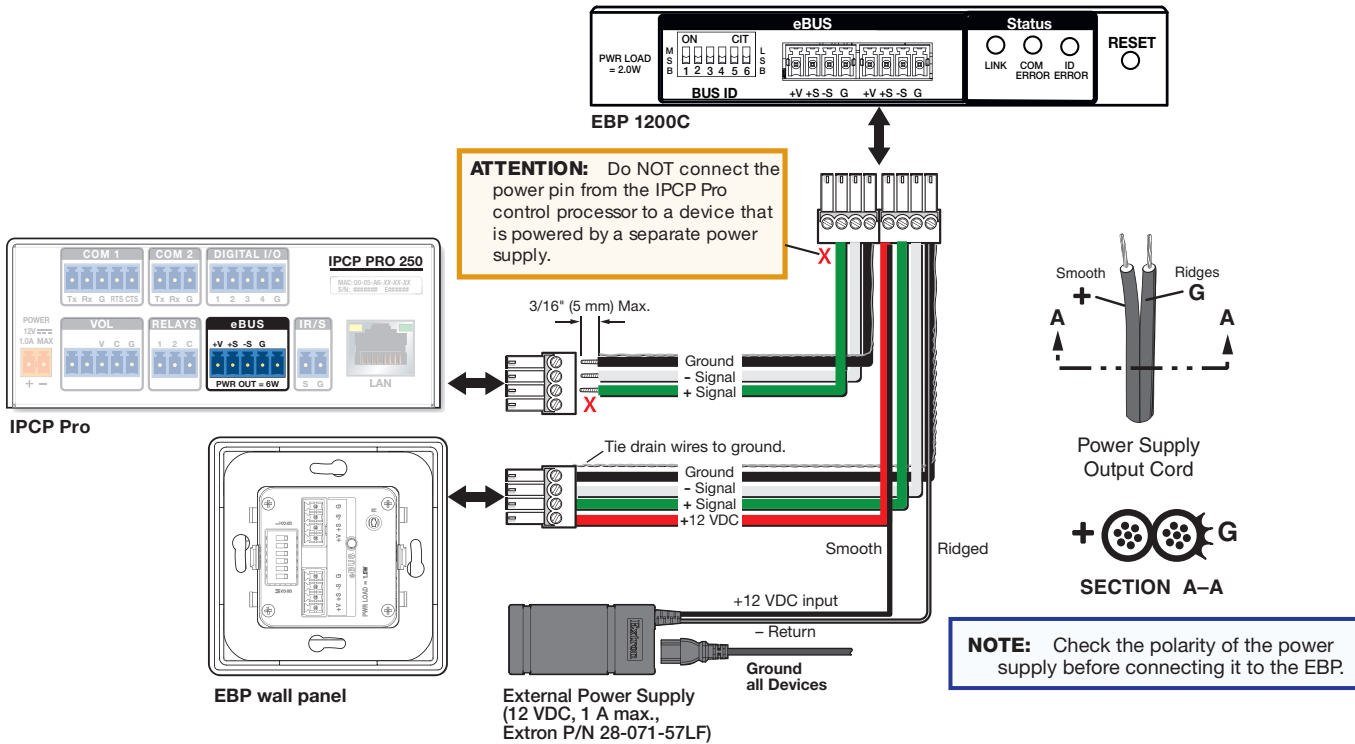

Figure 17. Powering an eBUS System with an Extron 12 VDC, 1A Power Supply

Configure the System

NOTE: EBPs are shipped with pre-labelled buttons in place but these buttons do not have any functions associated with them until they are configured with Global Configurator or programmed with Global Scriptor. See the *Global Configurator Help File* or *Global Scriptor Help File* as needed for step-by-step instructions and detailed information.

1. Create a new Global Configurator Plus or Professional project and configure the controller and any eBUS devices. The configuration tells the control processor how its ports function; how to control other products; what to monitor; when to do things; and whom to notify, how, and under what circumstances.
 - a. Configure ports on the control processor.
 - Select device drivers and link them to each assigned port.
 - Configure settings (serial protocol, relay behavior, digital input, volume control settings) as needed.
 - b. Set up monitors, schedules, macros, and local variables.
 - c. Set up the eBUS button panel buttons: assign appropriate commands and actions, macros, timers, local variables monitors, or feedback to the buttons.
2. Save the project.
3. Build and upload the system configuration to the control processor.

NOTE: Once the Global Configurator project has been set up, you can use Global Scriptor to program buttons and LEDs.

Test and Troubleshoot

1. Verify that the DIP switches on the EBPs are set to the desired address on each unit and that there are no DIP switch address conflicts in the system. If there is a bus ID conflict, the ID Error status LED lights red (see [EBP Bottom Panel](#) on page 8).
2. Verify that cables to and from the EBPs are wired the same at each end (pin 1 to pin 1, pin 2 to pin 2, and so forth). If there is no communication with the control processor, the Com Error status LED lights amber. If power and communication with the control processor are both good, the Link status LED lights green (see [EBP Bottom Panel](#) on page 8).
3. Test the system.
 - Press buttons on the EBPs and ensure the buttons light as desired and that the appropriate control commands or functions are triggered.
 - Ensure that the audio output responds correctly to the volume knob or button. Also ensure that the volume LEDs light correctly as you increase or decrease the audio gain.
4. Make adjustments to wiring, bus ID address, or system configuration as needed. Remember that the rear panel ports and DIP switches may not be accessible after the EBP is mounted. If needed, upload a revised configuration to the control processor.

If you have questions during installation and setup, you can file an [online technical support request](#) or call the Extron S3 Control Systems Support Hotline (1.800.633.9877).

EBP 1200C • Setup Guide (Continued)

Extron Headquarters +1.800.633.9876 (Inside USA/Canada Only) Extron USA - West +1.714.491.1500 +1.714.491.1517 FAX	Extron USA - East +1.919.850.1000 +1.919.850.1001 FAX	Extron Europe +800.3987.6673 (Inside Europe Only) +31.33.453.4040 +31.33.453.4050 FAX	Extron Asia +65.6383.4400 +65.6383.4664 FAX	Extron Japan +81.3.3511.7655 +81.3.3511.7656 FAX	Extron China +86.21.3760.1568 +86.21.3760.1566 FAX	Extron Middle East +971.4.299.1800 +971.4.299.1880 FAX	Extron Australia +61.8.8113.6800 +61.8.8351.2511 FAX	Extron India 1800.3070.3777 (Inside India Only) +91.80.3055.3777 +91.80.3055.3737 FAX
--	--	--	--	---	---	---	---	--