

IMPORTANT:
Go to www.extron.com for the complete user guide and installation instructions before connecting the product to the power source.

The Extron eBUS® 108 RAAP Button Panel (EBP) is a fully-customizable AV system control interface with eight buttons and a rotary encoder and eight-segment LED level indicator. It is designed for use with Extron eBUS-enabled Pro control systems. The 1U, 19 inches wide metal frame can be mounted in any standard equipment rack and the mounting plate has openings for up to four single-space or two double-space AAP™ Architectural Adapter Plates.

NOTE: These products are for use only with Extron UL Listed IPCP Pro control processors.

The EBP 108 RAAP has four eBUS ports that support power and communications between the IPCP Pro control processor and eBUS devices, and also accommodate system expansion. Up to eight eBUS endpoint devices such as EBP button panels and ECM control modules can be connected to the control processor and to each other in various cabling topologies. Cabling topology refers to the physical layout of cabling interconnections between devices in a network such as an eBUS system. eBUS systems can include daisy-chain, star, or a combination of both topologies (see the *eBUS Technology Reference Guide*, available at www.extron.com, for basic diagrams). Every endpoint device must have a unique identification address (bus ID) within the system.

Setup involves setting bus ID DIP switches on the EBPs, then using Extron Global Configurator® Plus and Professional (GCP) configuration software, the Toolbelt utility software, or Global Scriptor® programming software to configure the control processor. Once configured, the panels can be used for AV system control.

This guide provides basic instructions for an experienced installer to install any of these panels. For more details on the EBPs, see the *eBUS Technology Reference Guide*. For details on configuration, see the software help files.

Features

Rear Panel Features

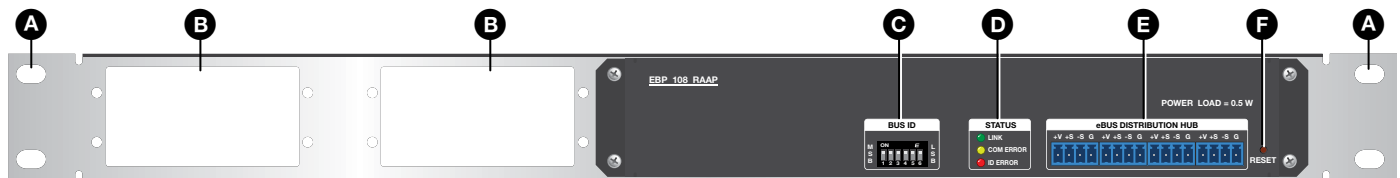

EBP 108 RAAP Rear Panel

Figure 1. EBP Rear Panel Features

- A Rack Mounting Holes** — Used to mount the device to standard 19-inch equipment racks (see [Step 8: Mount the EBPs](#) on page 10).
- B AAP Mounting Slots** — Used to mount up to four single-space or two double-space AAPs.
- C BUS ID DIP Switches** — Up to eight devices can be connected to one control processor. Each device connected to the same control processor must have a unique BUS ID, which is set using DIP switches (see [Step 4: Set BUS ID Addresses](#) on page 4).
- D Status LEDs** — The EBP 108 RAAP has yellow, red, and green LEDs that provide diagnostic information about the connection, communication, and power status of the panels. For more information about how the LEDs are used for troubleshooting, see [Step 7: Test and Troubleshoot](#) on page 9.
- E eBUS Distribution Hub (4 ports)** — The four-pole captive screw connectors use the Extron eBUS protocol to connect the panel to a controller and to other panels (see [Step 5: Cable All Devices](#) on page 7).
- F Reset Button** — If required, press this recessed button to reset the firmware to the factory installed version.

EBP 108 RAAP Button Panel • Setup Guide (Continued)

To reset the firmware

1. Disconnect the eBUS cable that is providing power.
2. Press and hold down the **Reset** button and, while holding down the **Reset** button, reconnect eBUS cable.
3. Release the **Reset** button 1 second after reconnecting power. During the reset process, the front panel buttons are not lit. When the eBUS Connection Status LED lights, the reset process is complete.

NOTES:

- If the reset is carried out while the EBP is receiving power from a 12 VDC power supply, the firmware is reset to the factory default.
- If the reset is carried out while the EBP is receiving power from a control processor, the firmware is reset to the factory default but the control processor may then push a more recent version of the firmware to the EBP.

Front Panel Features

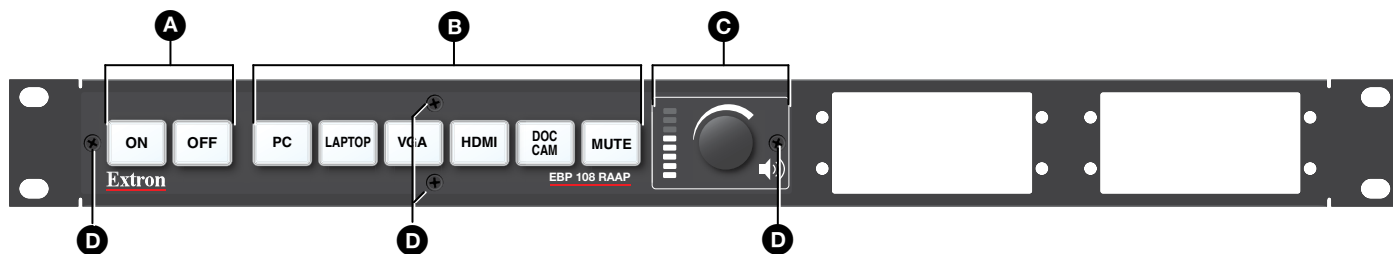

Figure 2. EBP 108 RAAP Front Panel

The buttons and encoders must be configured or programmed to carry out their functions.

- A Power Buttons** — These two buttons control the power to a display
- B Function Buttons** — These six buttons can be set up to carry out a variety of functions, either by configuration with Global Configurator Plus and Professional, or programming with Global Scripter, (see the software help file for more information).
- C Volume Control LEDs and Rotary Encoder** — Use the encoder to adjust the volume level. The LEDs provide a visual representation of the volume level.
- D Front Panel Screws** — These four Phillips-head screws hold the faceplate to the unit.

Planning the System and Installation

When planning to install an eBUS system you must consider how many EBP button panels to use, maximum cable distance, cabling topology, and mounting. See the *eBUS Technology Reference Guide* for more information about eBUS topologies.

Installation

Step 1: Get Ready

Use the following checklist to prepare for the installation.

- Download and install the latest version of the software, firmware, and device drivers needed to configure the IPCP Pro control processor and control the connected AV products. See the *IPCP Pro Series User Guide* (available at www.extron.com) for details on software and drivers.
- Obtain network information (IP addresses, passwords, DHCP settings, and so on) and the MAC address for the control processor.
- Obtain model names, drivers, and setup information for AV devices.
- Determine which eBUS cabling topologies to use and obtain cables, mounting hardware, and any power supplies or hubs required by that configuration (see the *eBUS Technology Reference Guide* for more information about eBUS topologies).

Step 2: Prepare the Installation Site

ATTENTION:

- Installation and service must be performed by authorized personnel only.
- L'installation et l'entretien doivent être effectués par le personnel autorisé uniquement.
- If the EBP will be installed into fine furniture, it is best to hire a licenced, bonded craftsman to cut the access hole and perform the physical installation so the surface will not be damaged.
- S'il est prévu d'installer le EBP dans du beau mobilier, il est préférable de faire appel à un artisan autorisé et qualifié pour couper le trou d'accès et réaliser l'installation de telle façon que la surface ne soit pas endommagée.
- Follow all national and local building and electrical codes that apply to the installation site.
- Respectez tous les codes électriques et du bâtiment, nationaux et locaux, qui s'appliquent au site de l'installation.

Americans with Disabilities Act (ADA) compliance

When planning where to install these devices, you may need to consider factors affecting accessibility of the button panel such as height from the floor, distance from obstructions, and how far a user must reach to press the buttons. For guidelines, see sections 307 ("Protruding Objects") and 308 ("Reach Ranges") of the 2010 ADA Standards for Accessible Design available at <http://www.ada.gov/regs2010/2010ADASTandards/2010ADASTandards.pdf>.

Step 3: Change Button Labels or Knob

You can replace button labels or the volume control knob. Some button labels ship with the unit. You can create and print your own customized labels using Extron Button Label Generator software.

Changing the button labels

1. Remove the four Phillips-head screws holding the faceplate to the unit (see figure 2, **D**, on the previous page) and remove the faceplate.
2. Gently separate the button lens cap from its white diffuser, insert the end of the provided Extron removal tool into the corner notch, and gently twist the tool (see figure 3, **1**).
3. Remove the label insert from the button cap.

TIP: If the insert does not come out easily, use a piece of sticky tape to pull it out of the button cap.

4. Select one of the button labels from the printed label sheets included with the unit. Remove the label from its backing and remove the clear, protective film from the other side of the label.
5. Insert the button label into the button cap (**2**).
6. Align the cap with the white diffuser and the panel opening, and press the clear cap into place on the button.
7. Attach the faceplate to the EBP by aligning the openings of the faceplate with the buttons, the knob, and the LEDs and place the faceplate against the unit.
8. Secure the faceplate to the unit using the four Phillips-head screws removed in step 1.

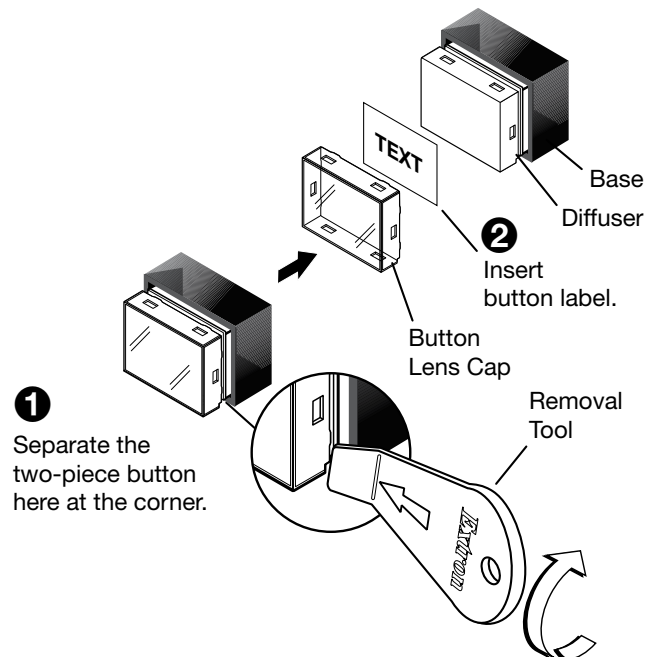
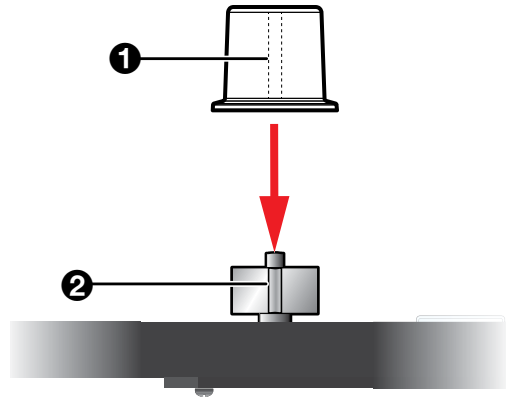

Figure 3. Replacing Buttons

EBP 108 RAAP Button Panel • Setup Guide (Continued)

Replacing the volume control knob

1. To remove a knob, firmly grasp the knob and pull it away from the EBP. There is no need to remove the faceplate.
2. To replace the knob, align the ridge **inside** the new knob (figure 4, ①) with the channel on the knob control (②) and allow the magnet in the knob to snap into place.



EBP 108 RAAP Top View

Figure 4. Replacing the Volume Control Knob

Step 4: Set BUS ID Addresses

Up to eight devices can be connected to one control processor. In order for the control processor to be successfully configured, each device connected to the same control processor must have a unique six-bit, BUS ID, which is set with the DIP switch assembly on the rear panel of the EBP (see figure 1, ③, on page 1). If two or more modules have the same bus ID, address conflicts may cause one or more of the panels to not be recognized by the IPCP Pro control processor. If there is an address conflict, the red status LED (figure 1, ④) lights steadily (see also Step 7: Test and Troubleshoot, step 2 on page 9).

Various combinations of the six DIP switches set to On or Off provide 64 addresses: 0 is a reserved eBUS ID and the configurable eBUS ID range is 1 through 63 (see the table on the two following pages). The section below shows an example of binary to decimal conversion.

eBUS ID Setup

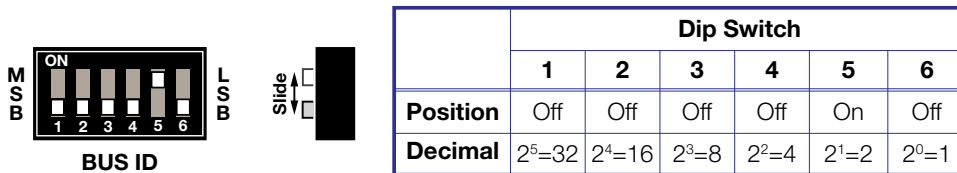

Figure 5. eBUS ID Setup

Add the decimal numbers for each of the DIP switches that are set to On to obtain the address of the device. In figure 5, only DIP switch #5 is on and the rest are off, which means the address for the device in figure 5 is $0+0+0+0+2+0=2$.

NOTES:

- Any address can be used except address 0 (binary: 000000), which is reserved as the address of the controller.
- Switch 1 (on the left) is the highest value (32, the most significant bit) and is labelled MSB.
- Switch 6 (on the right) is the lowest value (1, the least significant bit) and is labelled LSB.
- **Up = On = 1, Down = Off = 0**

The factory default address for the EBP 108 RAAP is 25 (BUS ID = 011001). The ID can be changed to any valid value. The table on the following two pages shows the DIP switch settings for all 64 possible addresses.

Setting eBUS ID Numbers

In the table below, a DIP switch setting shown as 0 is equivalent to **Off**. A DIP switch setting shown as 1 is equivalent to **On**.

NOTE: The ID number 0 (switch setting 000000) is reserved for the control processor and cannot be used by an eBUS device.

		DIP Switch Setting						Decimal Value			DIP Switch Setting						Decimal Value
		1	2	3	4	5	6				1	2	3	4	5	6	
MSB		LSB	0	0	0	0	0	0	0	0	1	1	1	1	15		
	1		2	3	4	5	6	1	2	3	4	5	6				
MSB		LSB	0	0	0	0	0	1	0	1	0	0	0	0	16		
	1		2	3	4	5	6	1	2	3	4	5	6				
MSB		LSB	0	0	0	0	1	0	0	1	0	0	0	1	17		
	1		2	3	4	5	6	1	2	3	4	5	6				
MSB		LSB	0	0	0	0	1	1	0	1	0	0	1	0	18		
	1		2	3	4	5	6	1	2	3	4	5	6				
MSB		LSB	0	0	0	1	0	0	0	1	0	0	1	1	19		
	1		2	3	4	5	6	1	2	3	4	5	6				
MSB		LSB	0	0	0	1	0	1	0	1	0	1	0	0	20		
	1		2	3	4	5	6	1	2	3	4	5	6				
MSB		LSB	0	0	0	1	1	0	0	1	0	1	0	1	21		
	1		2	3	4	5	6	1	2	3	4	5	6				
MSB		LSB	0	0	0	1	1	1	0	1	0	1	1	0	22		
	1		2	3	4	5	6	1	2	3	4	5	6				
MSB		LSB	0	0	1	0	0	0	0	1	0	1	1	1	23		
	1		2	3	4	5	6	1	2	3	4	5	6				
MSB		LSB	0	0	1	0	0	1	0	1	1	0	0	0	24		
	1		2	3	4	5	6	1	2	3	4	5	6				
MSB		LSB	0	0	1	0	1	0	0	1	1	0	0	1	25		
	1		2	3	4	5	6	1	2	3	4	5	6				
MSB		LSB	0	0	1	0	1	1	0	1	1	0	1	0	26		
	1		2	3	4	5	6	1	2	3	4	5	6				
MSB		LSB	0	0	1	1	0	0	0	1	1	0	1	1	27		
	1		2	3	4	5	6	1	2	3	4	5	6				
MSB		LSB	0	0	1	1	0	1	0	1	1	1	0	0	28		
	1		2	3	4	5	6	1	2	3	4	5	6				
MSB		LSB	0	0	1	1	1	0	0	1	1	1	0	1	29		
	1		2	3	4	5	6	1	2	3	4	5	6				

EBP 108 RAAP Button Panel • Setup Guide (Continued)

		DIP Switch Setting						Decimal Value			DIP Switch Setting						Decimal Value		
		1	2	3	4	5	6				1	2	3	4	5	6			
MSB		LSB	0	1	1	1	1	0	30	MSB		LSB	1	0	1	1	1	1	47
			0	1	1	1	1	1	31				1	1	0	0	0	0	48
MSB		LSB	1	0	0	0	0	0	32	MSB		LSB	1	1	0	0	0	1	49
			1	0	0	0	0	1	33				1	1	0	0	1	0	50
MSB		LSB	1	0	0	0	1	0	34	MSB		LSB	1	1	0	0	1	1	51
			1	0	0	0	1	1	35				1	1	0	1	0	0	52
MSB		LSB	1	0	0	1	0	0	36	MSB		LSB	1	1	0	1	0	1	53
			1	0	0	1	0	1	37				1	1	0	1	1	0	54
MSB		LSB	1	0	0	1	1	0	38	MSB		LSB	1	1	0	1	1	1	55
			1	0	0	1	1	1	39				1	1	1	0	0	0	56
MSB		LSB	1	0	1	0	0	0	40	MSB		LSB	1	1	1	0	0	1	57
			1	0	1	0	0	1	41				1	1	1	0	1	0	58
MSB		LSB	1	0	1	0	1	0	42	MSB		LSB	1	1	1	0	1	1	59
			1	0	1	0	1	1	43				1	1	1	1	0	0	60
MSB		LSB	1	0	1	1	0	0	44	MSB		LSB	1	1	1	1	0	1	61
			1	0	1	1	0	1	45				1	1	1	1	1	0	62
MSB		LSB	1	0	1	1	1	0	46	MSB		LSB	1	1	1	1	1	1	63
			1	0	1	1	1	0	46				1	1	1	1	1	1	63

Step 5: Cable All Devices

Attach cables using the diagrams in this section as a guide. Connect a 4-pole captive screw connector to each end of the cable, wiring both ends as shown in figure 6. In most cases the EBPs are powered by the IPCP Pro control processor that provides the eBUS signal. Power is carried on the V+ pin of each eBUS connection.

The four connectors are:

- **+V** — carries 12 VDC power from the controller, active hub, or power supply
- **+S** — carries the positive data signal
- **-S** — carries the negative data signal
- **G** — ground

Extron STP20-2/1000 or STP20-2P/1000 cable is recommended for eBUS connections.

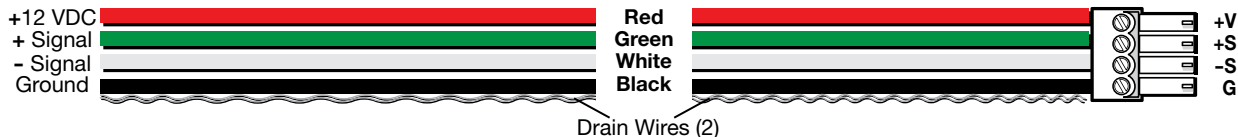

Figure 6. Basic eBUS Connector Wiring and Cable Color Code

NOTES:

- The four eBUS ports are interchangeable: any port can be used to connect the device to a controller or EBDB distribution hub and any port can be used to daisy-chain the device to another EBP.
- Connect up to eight eBUS devices for each IPCP Pro control processor.
- Wire the connectors in the same way at both ends.
- Do not exceed a total of 1000 feet (305 meters) of cable for connections between the IPCP Pro and all the EBP panels.
- Do NOT power an EBP from more than one power source. Power is provided by the IPCP Pro. If additional power is required, use a PS 1220EB power supply and distribution hub, or an Extron 12 VDC power supply. If more than one power source is used in a system, disconnect the +V pin appropriately to ensure that the devices powered by the first source are isolated from the devices powered by the second source by (see [figure 7](#) on the following page).

ATTENTION:

- Always use a power supply supplied or specified by Extron. Use of an unauthorized power supply voids all regulatory compliance certification and may cause damage to the supply and the unit.
- Utilisez toujours une source d'alimentation fournie par Extron. L'utilisation d'une source d'alimentation non autorisée annule toute conformité réglementaire et peut endommager la source d'alimentation ainsi que l'unité.
- If not provided with a power supply, this product is intended to be supplied by a UL Listed power source marked "Class 2" or "LPS" and rated output 12 VDC, minimum 1.5 A.
- Si ce produit ne dispose pas de sa propre source d'alimentation électrique, il doit être alimenté par une source d'alimentation certifiée UL de classe 2 ou LPS et paramétré à 12 VDC et 1,5 A minimum.
- Unless otherwise stated, the AC/DC adapters are not suitable for use in air handling spaces or in wall cavities.
- Sauf mention contraire, les adaptateurs AC/DC ne sont pas appropriés pour une utilisation dans les espaces d'aération ou dans les cavités murales.
- The installation must always be in accordance with the applicable provisions of National Electrical Code ANSI/NFPA 70, article 725 and the Canadian Electrical Code part 1, section 16. The power supply shall not be permanently fixed to building structure or similar structure.
- Cette installation doit toujours être en accord avec les mesures qui s'applique au National Electrical Code ANSI/NFPA 70, article 725, et au Canadian Electrical Code, partie 1, section 16. La source d'alimentation ne devra pas être fixée de façon permanente à une structure de bâtiment ou à une structure similaire.

EBP 108 RAAP Button Panel • Setup Guide (Continued)

EBPs that are relatively far from the control processor (see the *eBUS Technology Reference Guide* at www.extron.com for details) can be connected to an optional Extron PS 1220EB eBUS power inserter (see figure 7), or an Extron 12 VDC desktop power supply (see figure 8).

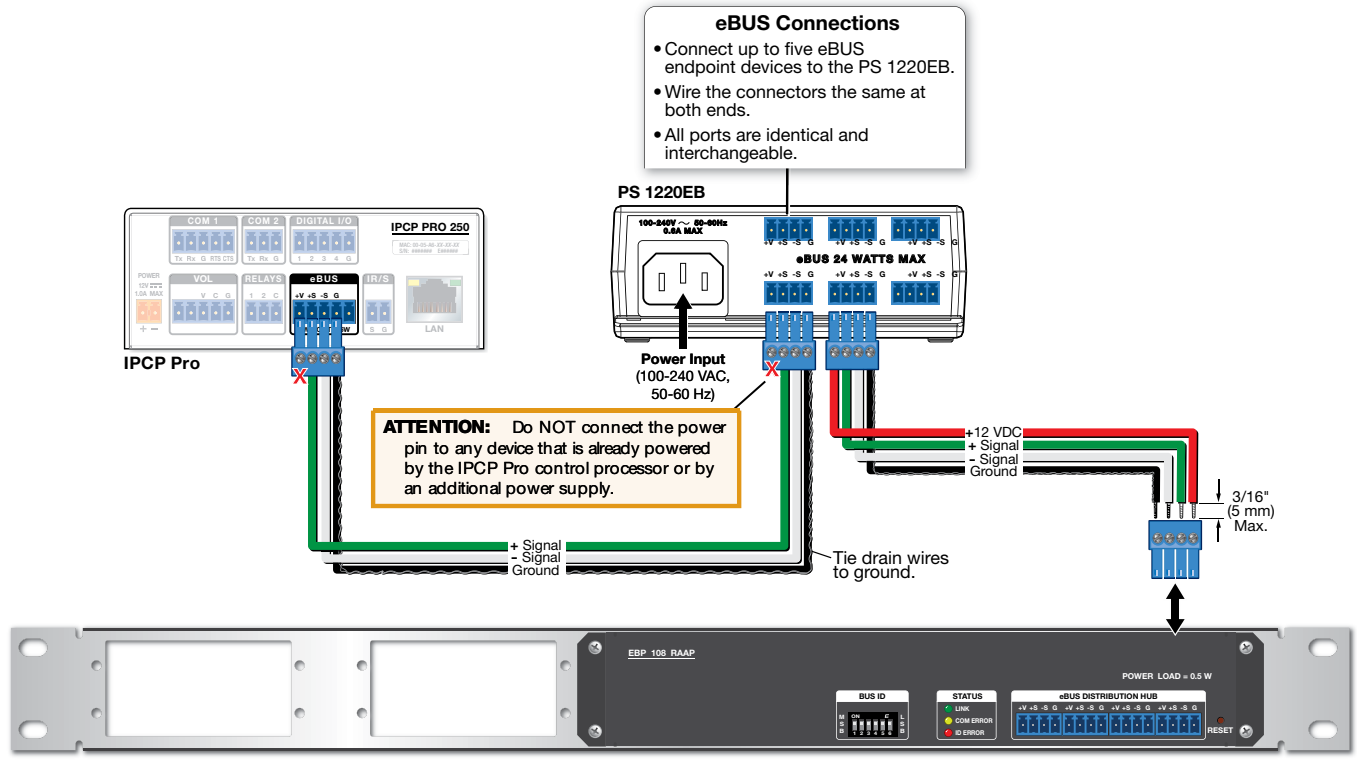

EBP 108 RAAP

Figure 7. Cabling an eBUS System with an PS 1220EB Power Supply and Distribution Hub

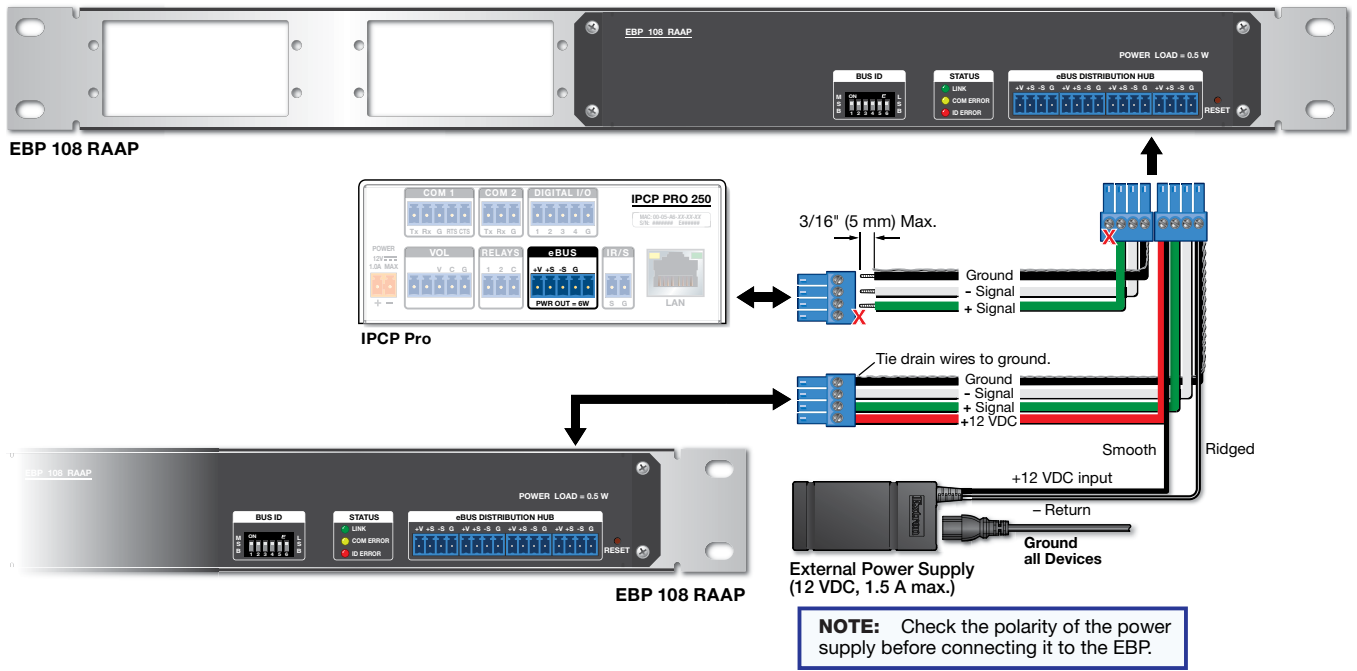

Figure 8. Cabling EBP Panels with an Extron Power Supply

Step 6: Configure or Program the System

EBPs are shipped with pre-labelled buttons in place but these buttons do not have any functions associated with them until they are configured with Global Configurator or programmed with Global Scripter. See the *Global Configurator Help File* or the *Global Scripter Help File* for step-by-step instructions and detailed information.

Step 7: Test and Troubleshoot

1. Verify that the DIP switches on the EBPs are set to the desired address on each device and that there are no BUS ID conflicts in the system (see [Step 4: Set BUS ID Addresses](#) on page 4).
2. The eBUS status LEDs (see [figure 1](#), **A**, on page 1) provide information about power and communication status and bus ID address conflicts.

The EBP 108 RAAP has three LEDs:

- **Off** — If all three LEDs are off, the device is not receiving power.
 - **Yellow LED**— Lights steadily when the device is receiving power but communication with the control processor is not confirmed.
 - **Red LED**— Lights steadily when there is a BUS ID address conflict.
 - **Green LED** — Lights steadily when power and communication are both confirmed.
3. Verify that cables to and from the EBPs are wired in the same way at each end (pin 1 to pin 1, pin 2 to pin 2, and so forth).
 4. Test the system.
 - Press buttons on the EBPs and ensure that the buttons light as desired and that the appropriate control commands or functions are triggered.
 - Ensure that the audio output responds correctly to the volume knob or button. Also ensure that the volume LEDs light correctly as you increase or decrease the audio gain.
 5. Make adjustments to wiring, BUS ID address, or system configuration as needed. Remember that the rear panel ports and DIP switches are not accessible after the EBP is mounted. If needed, upload a revised configuration to the control processor.

If you have questions during installation and setup, contact the [Extron S3 Sales & Technical Support](#) or the Extron S3 Control Systems Support Hotline (1.800.633.9877).

EBP 108 RAAP Button Panel • Setup Guide (Continued)

Step 8: Mount the EBPs

EBP panels can be installed directly into a standard 19-inch equipment rack.

1. Decide where the EBP 108 RAAP will be mounted.
2. (Optional.) Install AAPs as required. If you do not install AAPs, you can install blank plates to cover the holes.
3. Use the four provided rack-mounting screws to secure the button panel to any standard equipment rack or control console.
Follow the instructions in the [Underwriters Laboratories Guidelines for Rack Mounting](#) (see below) to ensure the rack is mounted safely.

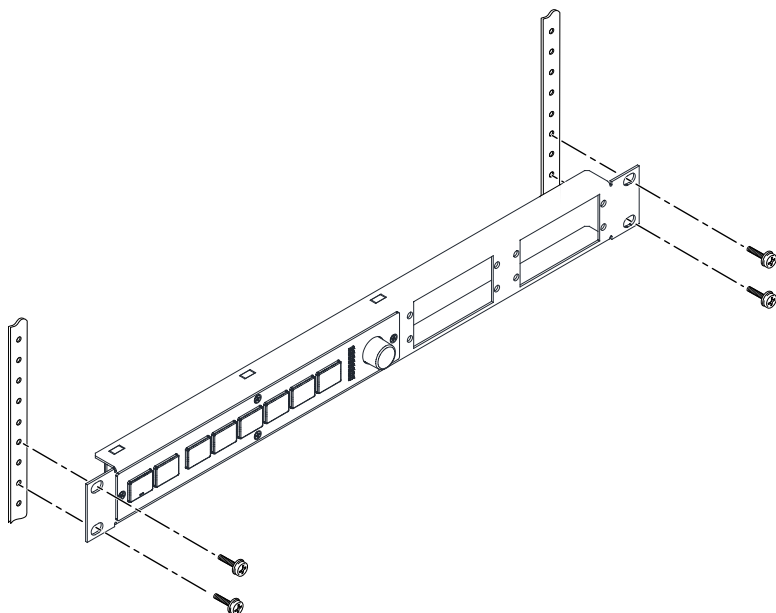

Figure 9. Mounting the EBP 108 RAAP in a rack

NOTE: You can mount up to four single-space or two double-space AAPs of your choice (see www.extron.com for available models). If you do not fill all the spaces, you can install blank plates to cover the holes.

4. Disconnect power from all devices at the source and run the cables to the EBP and AAP rear panels.
5. Connect the cables to the EBP rear panel (see [figure 1](#) on page 1 and see [Step 5: Cable All Devices](#) on page 7).
6. (Optional.) Connect cables to the AAPs. Follow the instructions provided with the AAP.
7. If you have not already done so, set the DIP switches to give the EBP a unique BUS ID (see [Step 4: Set BUS ID Addresses](#) on page 4).

Underwriters Laboratories Guidelines for Rack Mounting

The following Underwriters Laboratories (UL) guidelines are relevant to the safe installation of the EBP 108 RAAP in a rack:

- **Elevated operating ambient temperature** — If the unit is installed in a closed or multi-unit rack assembly, the operating ambient temperature of the rack environment may be greater than room ambient temperature. Therefore, install the equipment in an environment compatible with the maximum ambient temperature (T_{ma}: +104 °F, +40 °C) specified by Extron.
- **Reduced air flow** — Install the equipment in the rack so that the equipment gets adequate air flow for safe operation.
- **Mechanical loading** — Mount the equipment in the rack so that uneven mechanical loading does not create a hazardous condition.
- **Circuit overloading** — Connect the equipment to the supply circuit and consider the effect that circuit overloading might have on overcurrent protection and supply wiring. Give appropriate consideration to the equipment nameplate ratings when addressing this concern.
- **Reliable earthing (grounding)** — Maintain reliable grounding of rack-mounted equipment. Pay particular attention to supply connections other than direct connections to the branch circuit (such as the use of power strips).

For information on safety guidelines, regulatory compliances, EMI/EMF compatibility, accessibility, and related topics, see the [Extron Safety and Regulatory Compliance Guide](#) on the Extron website.