

WMK 100 Installation Notes

The Extron WMK 100 Wall Mounting Kit is used for hanging PoleVault® System A/V products on a wall near a flat screen display or short throw projector.

The WMK 100 has a 13" x 13" x 2.5" deep enclosure to mount the PoleVault switcher and the power supply, with room for cable management. It also has knockouts on all four sides which allow external raceways to be used where necessary for cabling.

CAUTION Maximum load for the WMK 100 is 15 lbs (7 kg).

The key components (base plate and cover) of the WMK 100 are shown in figure 1.

Included in the kit are:

(4) 1/4-20 x 2" pan head bolts, (4) 1/4" Kap toggle assemblies, (4) 1/4 x 1 3/4" masonry screws, (4) #14 x 1 3/4" self tapping metal/wood screws, (4) 6-32 x 1/4" button head hex screws.

Not shown but included are (3) 4-40 x 1/4" screws, (2) hook-and-loop straps.

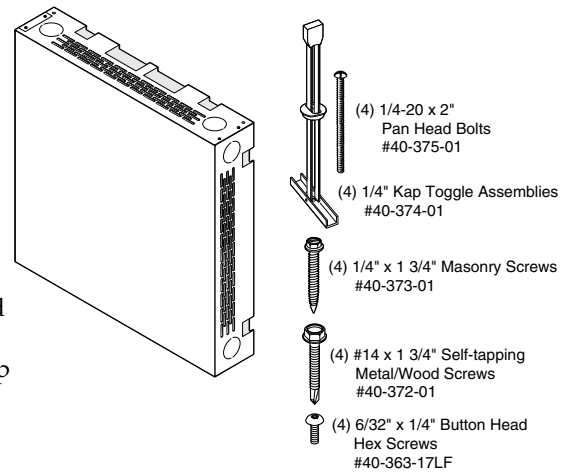

Figure 1 — WMK 100 parts

Installation

NOTE Refer to local building standards and codes to verify that the installation will meet the regulatory requirements. Observe all local and national building and safety codes, UL requirements, and ADA accessibility guidelines.

Before installation identify the type of wall (masonry or non-masonry) and the location where the WMK 100 will be installed. This determines the installation approach and the type of fasteners needed to secure the plate to the wall.

1. Mount the base plate

Follow the steps within 1A or 1B below, as applicable.

NOTE The base plate can be installed over an existing electrical outlet. The opening fits standard sized 2.75" x 4.5" wall plates. See figure 2 (inset).

1A. To mount the WMK 100 onto masonry walls:

- i. Hold the base against the wall, level it, and mark the positions of four slotted mounting holes (indicated by + marks in figure 2). Set the plate aside.

NOTE Use the top slot position at each mounting hole. Do not use both top and left slots as this will make it difficult to slide the plate down (see step iv).

- ii. Using a masonry drill bit, drill 1.75" (4.4 cm) deep pilot holes at the marked locations.
- iii. Screw in masonry screws until a gap of 1/8" to 3/8" (3 to 9 mm) remains between the wall and the screw heads.
- iv. Align the base plate's slotted mounting holes over the installed screws, then slide the plate down so the screws fit into the slots. 
- v. At this time, lightly tighten all the screws to secure the plate to the wall and verify level and position.

NOTE Do not over tighten, as the plate needs to be removed to attach the switcher and power supply before cabling.

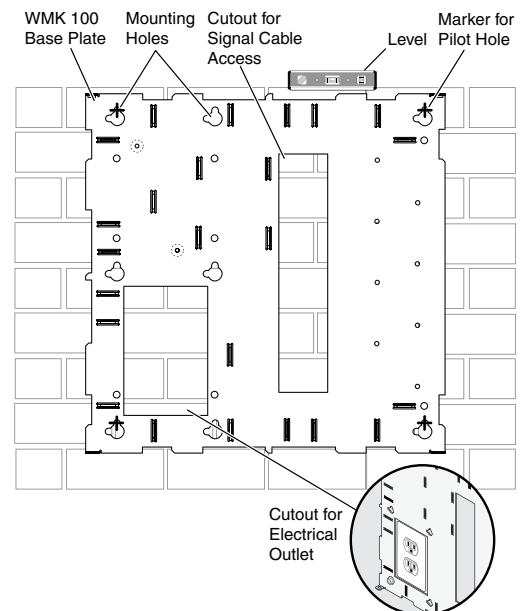

The plate can be aligned over an existing electrical outlet.

Figure 2 — Masonry wall mounting

Proceed to Step 2.

WMK 100 Installation Notes, cont'd

1B. To mount the WMK 100 onto a non-masonry wall:

- i. At the desired site locate the wall studs and mark their locations.

NOTE For ideal installation secure the base plate to at least one wall stud (see figure 3). Drywall Kap toggles can be used for holes not aligned with studs.

The base plate can be installed over an existing electrical outlet. The opening fits standard sized 2.75" x 4.5" wall plates. See inset on figure 2.

- ii. Hold and level the base plate against the wall and mark the positions of the slotted mounting holes that are on the stud lines (see figure 3, indicated by + marks). Where applicable, mark the mounting holes on the wall for drywall toggles. Set the plate aside.
- iii. Drill 1.75" (4.4 cm) deep pilot holes at the marked locations.
- iv. Insert the self tapping screws into the pilot holes, until a gap of 1/8" to 3/8" (3 to 9 mm) remains between the wall and the screw heads.

NOTE If using toggle assemblies see figure 4 for installation method.

- v. Align the base plate's slotted mounting holes over the installed screws, then slide the plate down so the screws fit into the slots. 
- vi. At this time, lightly tighten all the screws to ensure plate fits flush to the wall and verify level and position.

NOTE Do not over tighten, as the plate needs to be removed to attach the switcher and power supply before cabling.

- vii. If the cables are to be run behind the wall to the WMK location, mark the cutout area on the wall for the signal cable access hole (see figure 3).
- viii. Remove the base plate and cut out the marked area.

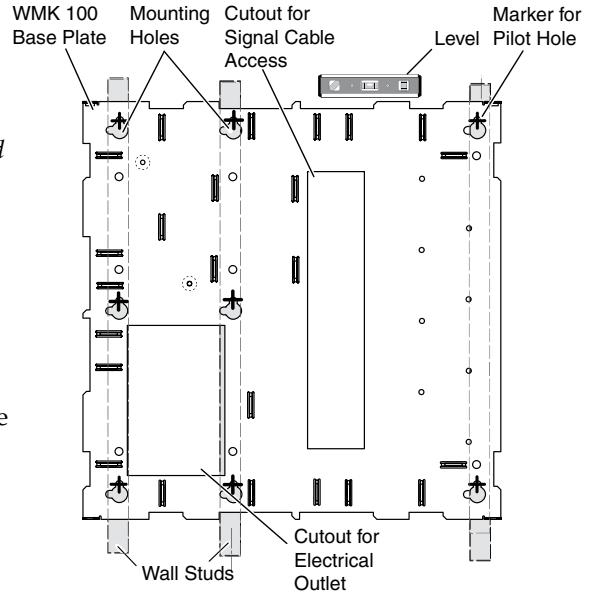

Figure 3 — Non-masonry wall mounting

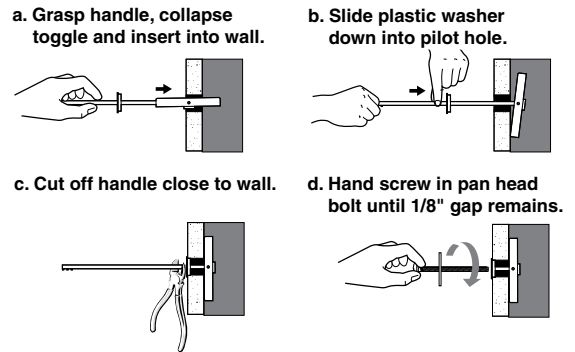

Figure 4 — Toggle assembly installation

2. Mount the switcher and power supply

- a. Remove the WMK 100 base plate from the wall, and with the switcher's rear ports facing the cable access hole, align the two corner holes in the base of the switcher with the two outermost device mounting holes in the WMK 100 base plate. Secure with the supplied 440 x 1/4" screws.
- b. Attach the power supply above the electrical outlet cutout, with the supplied hook-and-loop straps. Attach it so the cables are easily and safely routed to the electrical outlet and switcher alike.
- c. Re-attach the plate to the wall and secure firmly.

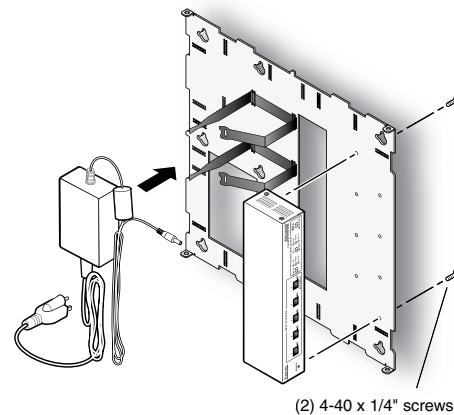

Figure 5 — Attach switcher and power supply to base plate

3. Run cables

Run signal cables from the proposed PoleVault input wall plates, control device location, and the speakers to the WMK 100 location. Cables can be routed behind the walls, or through a surface raceway (e.g., Wiremold 700 or 2400 series) directly to the WMK 100.

3A. If running cable behind the walls:

- i. Run all the cables from the various locations to the WMK and through the access hole.

3B. If using a surface raceway:

- i. Attach the WMK cover to the base plate, then identify and mark the most suitable raceway entrance to the WMK 100.
- ii. Run the raceway from the signal source, speaker, and display locations to the marked raceway entrance at the WMK.
- iii. Remove the WMK cover, and remove the desired knockout.
- iv. Attach the raceway to the wall and run cables from the sources and outputs through the raceway to the WMK.

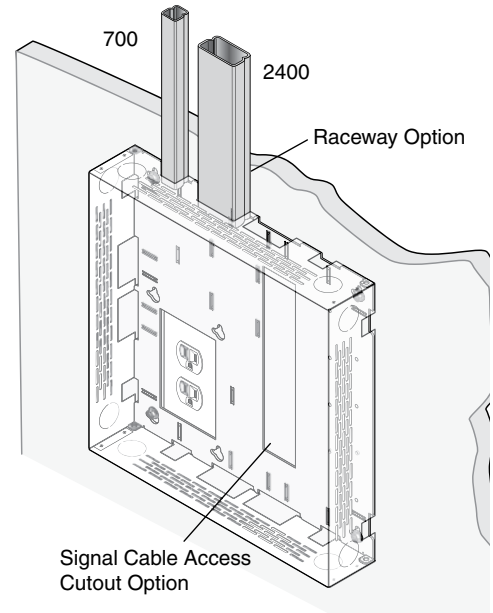

Figure 6 — Cabling run options

4. Cable the switcher

- a. Connect the cables from the PoleVault transmitters, control device (MediaLink® Controller), speakers, and optional accessories (VoiceLift, Page Sensor Kit) to the rear ports of the switcher (see below). Refer to the *PVS 305SA Setup Guide* for additional details.

NOTE If using a device other than a PVS 305SA (e.g., PVS 204SA Plus), refer to that device's user manual for details.

- b. Run VGA and composite video cables from the switcher to the output display device through the wall or where fitted, the raceway.

- c. Connect the power supply to the switcher and plug it in to the electrical outlet.

NOTE If the electrical outlet is outside the WMK, pass the IEC power cable out through one of the raceway knockouts.

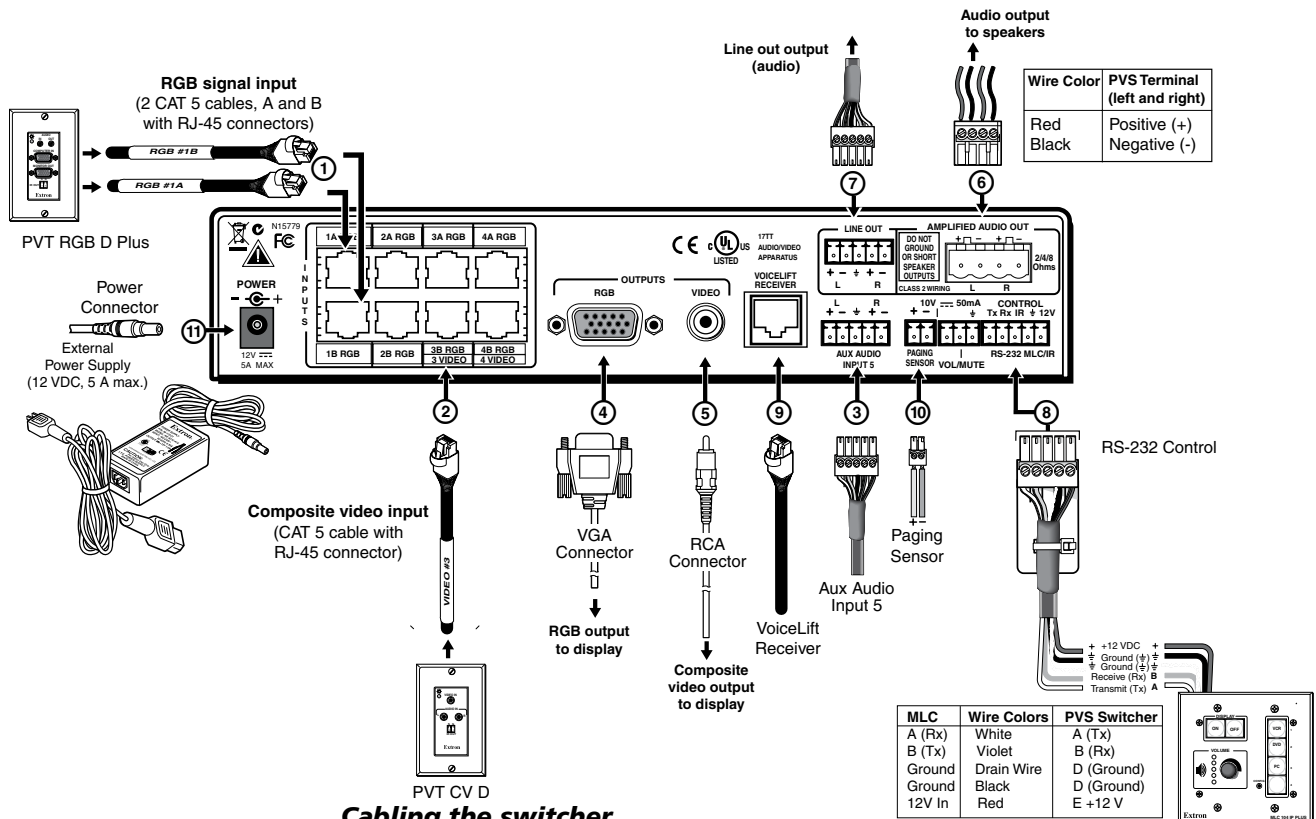

WMK 100 Installation Notes, cont'd

5. Final installation.

- a. After completion of cabling, place the cover over the installed plate, and secure at each corner with the provided 6-32 button head screws.

NOTE Ensure any cables exiting the box (e.g., to display device and external electrical outlet) pass through a raceway knockout.

- b. Switch on the display device, control device, signal sources and adjust and configure the system as needed.

For full configuration and setup details, refer to the *PoleVault System Installation Manual*, the *MLC 104 Plus Series Reference Manual*, and the *PVS 305SA User's Manual*, all available online at www.extron.com.

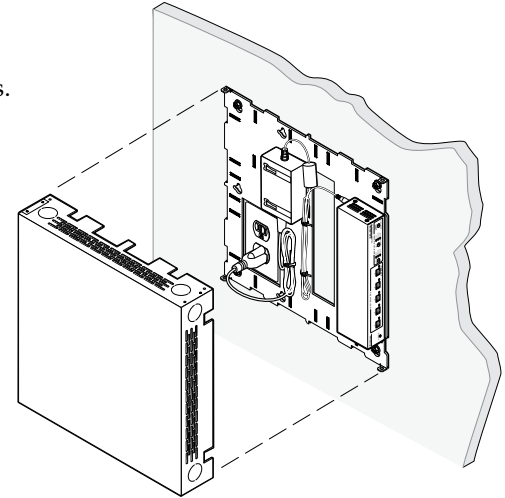

Figure 7— Attach WMK 100 cover

General Specifications

Mounting

Wall mount.....	Yes, with included hardware
Maximum load capacity.....	15 lbs (6.8 kg)
Material.....	Steel

Dimensions

Base plate.....	12.8" H x 12.8" W x 0.5" D (32.5 cm H x 32.5 cm W x 1.3 cm D)
Cover.....	13.0" H x 13.0" W x 2.5" D (33.0 cm H x 33.0 cm W x 6.4 cm D)
Product weight.....	4 lbs (1.8 kg)
Shipping weight.....	6 lbs (3 kg)
Vibration.....	ISTA 1A in carton (International Safe Transit Association)

Regulatory compliance

Safety.....	c-UL, UL
Warranty.....	3 years parts and labor

NOTE Specifications are subject to change without notice.

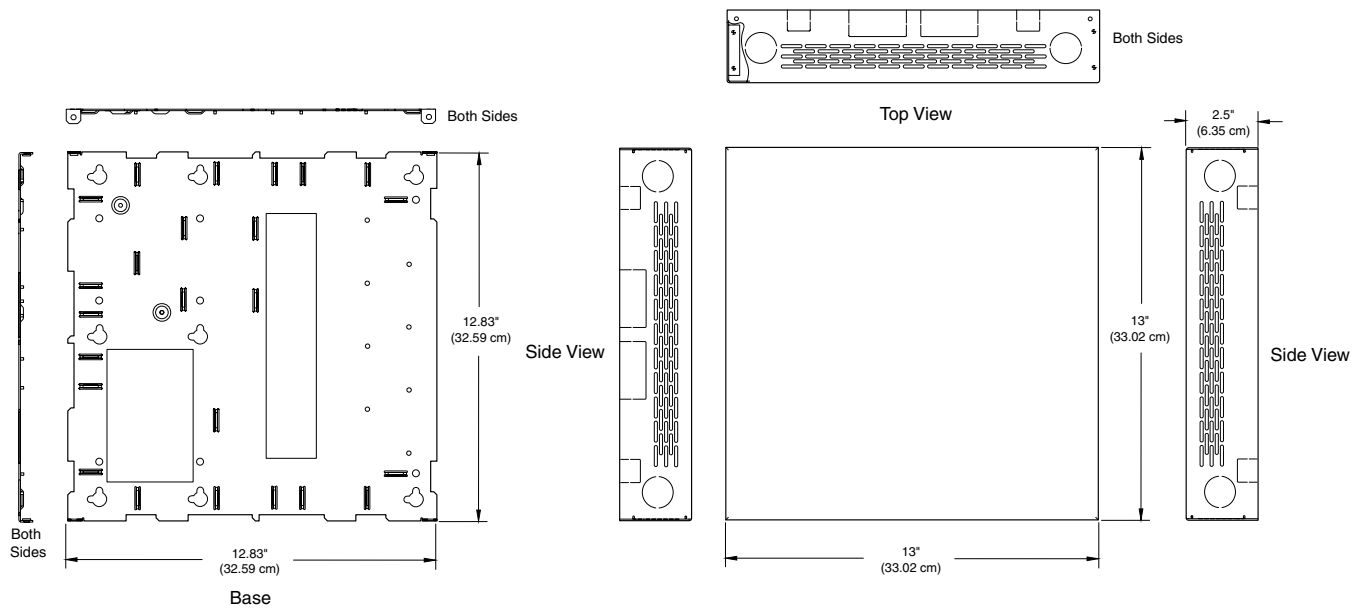

Extron USA - West Headquarters +800.633.9876 Inside USA / Canada Only +1.714.491.1500 +1.714.491.1517 FAX	Extron USA - East +800.633.9876 Inside USA / Canada Only +1.919.863.1794 +1.919.863.1797 FAX	Extron Europe +800.3987.6673 Inside Europe Only +31.33.453.4040 +31.33.453.4050 FAX	Extron Asia +800.7339.8766 Inside Asia Only +65.6383.4400 +65.6383.4664 FAX	Extron Japan +81.3.3511.7655 +81.3.3511.7656 FAX	Extron China +400.883.1568 Inside China Only +86.21.3760.1568 +86.21.3760.1566 FAX	Extron Middle East +971.4.2991800 +971.4.2991880 FAX
--	--	---	---	---	--	---