

IMPORTANT:
Go to www.extron.com for the complete user guide, installation instructions, and specifications before connecting the product to the power source.

BUC 202 • Setup Guide

This guide provides instructions for an experienced installer to set up and operate the Extron BUC 202 two channel unbalanced/balanced audio converter and line driver.

Rear Panel Features and Cabling

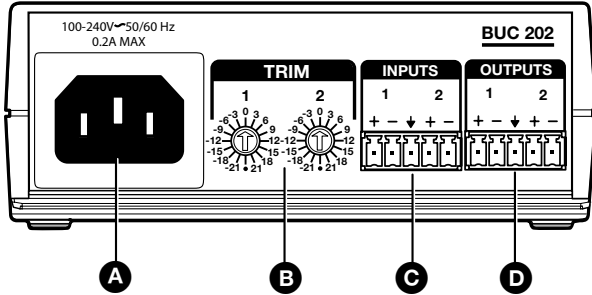

- A AC power** — Connect to standard AC power: 100 to 240 VAC, at 50 or 60 Hz.
- B Trim adjustment (channels 1 and 2)** — Adjust the audio input level for the channel using the 16-position rotary switch. This switch sets the level in 3 dB increments from -21 dB to +21 dB. The arrow on the shaft indicates the current setting.

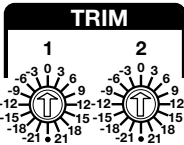

NOTE: Unity gain (0 dB) for both channels is at the 12 o'clock (vertical) position with the arrow on the shaft pointing to the 0 position. When the switch is set to the bottom position (indicated by a dot) the signal is muted (see [Adjusting the Trim](#)).

- C Input connector** — This 3.5 mm 5-pole captive screw connector accepts line level balanced or unbalanced, mono or stereo audio signals (see the illustrations below for proper wiring).

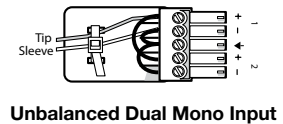
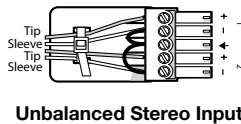
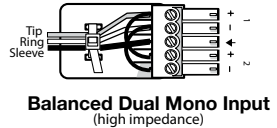
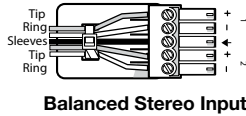
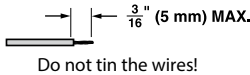

Tip-ring-sleeve and tip-sleeve connections:

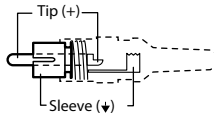
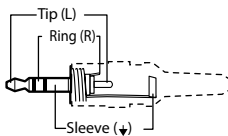

BUC 202 • Setup Guide (Continued)

ATTENTION: The length of the exposed wires in the stripping process is critical. The ideal length is 3/16 inches (5 mm). Any longer and the exposed wires may touch, causing a short circuit between them. Any shorter and the wires can be easily pulled out even if tightly fastened by the captive screws.

NOTE: Do not tin the wires. Tinned wires are not as secure in the connector and could be pulled out.

- D Output connector** — The 3.5 mm 5-pole captive screw connector outputs balanced or unbalanced audio signals (see the illustrations below for proper wiring).

ATTENTION: For unbalanced audio output, connect sleeves to the center ground pin. **DO NOT** connect sleeves to the negative (-) contacts. This would create a short and possibly damage the unit.

NOTE: Do not tin the wires. Tinned wires are not as secure in the connector and could be pulled out.

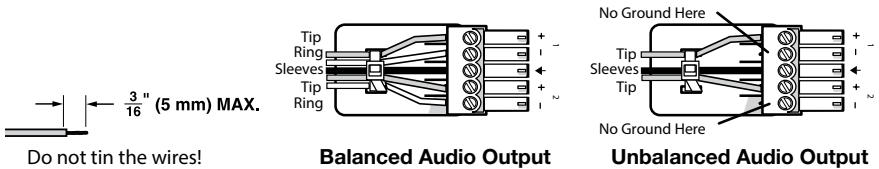

Front Panel

The green power LED on the front panel lights when the BUC 202 is receiving power.

Adjusting the Trim

The BUC 202 can be wired in four different configurations:

- Balanced input to unbalanced output
- Unbalanced input to balanced output
- Balanced input to balanced output
- Unbalanced input to unbalanced output

Follow the steps below to adjust the trim:

1. Disconnect power from all devices.
2. Wire the BUC 202 for either balanced or unbalanced stereo or dual mono audio input.
3. Wire the BUC 202 for either balanced or unbalanced audio output.
4. Set the trim adjustment:
 - a. Determine the input and output signal types (balanced or unbalanced) and whether it is consumer or professional audio.

Find the trim adjustment setting according to the following table.

Input \ Output		Balanced		Unbalanced	
		Consumer ¹	Professional ²	Consumer ¹	Professional ²
Balanced	Consumer ¹	0 dB	12 dB	6 dB	18 dB
	Professional ²	-12 dB	0 dB	-6 dB	6 dB
Unbalanced	Consumer ¹	0 dB	12 dB	6 dB	18 dB
	Professional ²	-12 dB	0 dB	-6 dB	6 dB

NOTES:

¹ Consumer line level is -10 dBV ≈ -8 dBu.

² Professional line level is +4 dBu.

- b. Use a small screwdriver to turn the appropriate trim adjustment switch to the desired setting.
- 5. Reconnect power to all devices to test the audio.
- 6. If necessary, readjust the trim.

Using the ZipClip™ 200

To attach the BUC 202 to the ZipClip 200 mounting clip:

1. Insert the bottom of the BUC 202 down into the clip, starting with one end.
2. Pivot the other end down and press until the clip snaps into place.

To remove the BUC 202 from the ZipClip:

1. Press the tab on the ZipClip (❶).
2. Pivot the BUC 202 and lift it out of the ZipClip (❷).

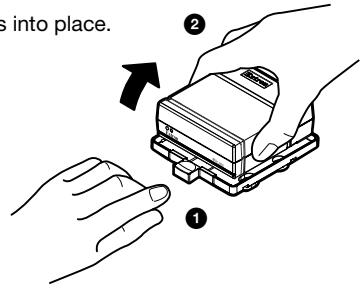

To fasten the tie wraps for cable strain relief:

1. Attach the BUC 202 to the ZipClip 200 mounting clip as described previously.
2. Fasten loose cables to the ZipClip base.
 - a. Insert the tie wraps (“zip ties”) along the notches on the side of the BUC 202 and through the tie wrap anchor points on the ZipClip, then around the cables.
 - b. Connect and pull the tie wraps until they are secure. Do not overtighten.

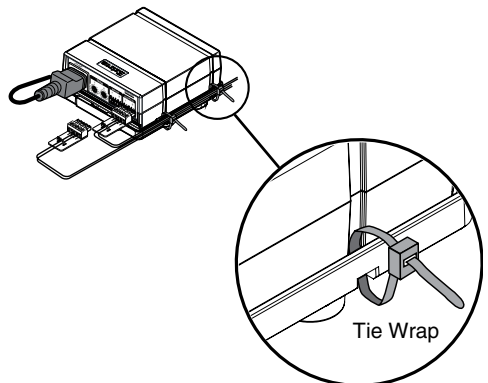

BUC 202 • Setup Guide (Continued)

Mounting to Rack Rails Using a ZipClip

1. Fasten the ZipClip 200 mounting clip to a rack rail using two rack screws as shown in the diagram on the right.
2. Insert the BUC 202 into the ZipClip as described previously and press to snap it into place.

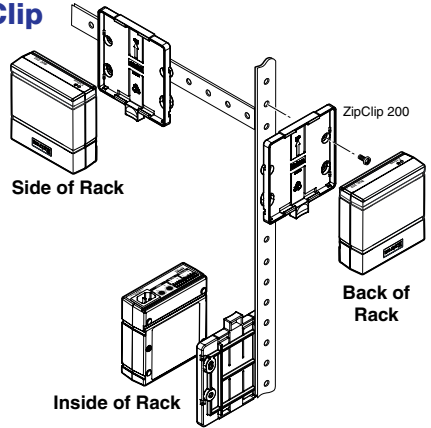

Mounting to a Rack Shelf

The BUC 202 is one-quarter rack width wide. Up to four BUC 202 units can be mounted side by side directly onto a rack shelf.

1. Align the threaded holes in the bottom of the BUC 202 with the holes in an Extron rack shelf (1). Fasten the BUC 202 to the shelf with two 4-40 x 3/16 inch screws as shown on the right.
2. Bolt the rack shelf to the rack (2).

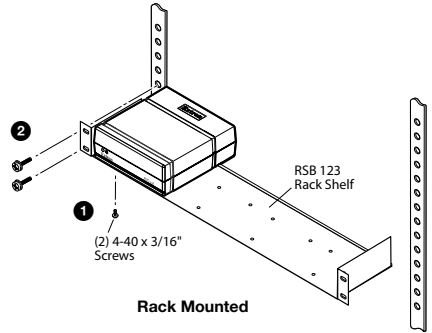

Under-Furniture Mounting

NOTE: The ZipClip is shipped with a set of four wood screws.

1. Attach the ZipClip to the furniture using two or more wood screws as shown on the right (1). Make sure the clip is oriented with the appropriate side facing the mounting surface and with the tab accessible from the front of the furniture.
2. Insert the BUC 202 into the ZipClip as described previously and press to snap it into place (2).

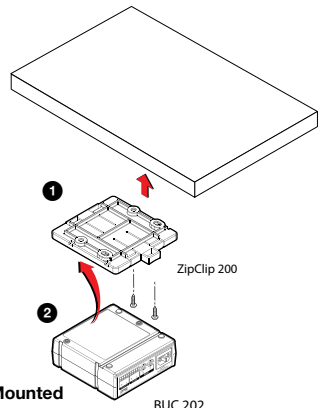

Extron Headquarters +1.800.633.9876 (Inside USA/Canada Only)	Extron Asia +65.6383.4400	Extron China +86.21.3760.1568	Extron Korea +82.2.3444.1571
Extron Europe +31.33.453.4040	Extron Japan +81.3.3511.7655	Extron Middle East +971.4.299.1800	Extron India +91.80.3055.3777