



TeamWork® • Installation Guide

TeamWork

Extron TeamWork is a fully customizable collaboration system comprised of an Extron switcher, “Show Me” cables, a control processor, and a Cable Cubby® enclosure. This installation guide provides the information needed for an experienced installer to set up these systems.

ATTENTION:

- The information in this guide refers to a typical TeamWork system. The devices provided in your kit may differ from those shown in the illustrations.
- If your system uses a different IPL controller, switcher, or Cable Cubby from the ones shown in this guide consult the user guide for your model before connecting or configuring that device. The user guides are available on line at www.extron.com.

In a typical TeamWork application, shown below, digital or analog input devices (laptops and a tablet) connect to the switcher, using “Show Me” cables. The “Show Me” cables allow the user to select the input on the switcher.

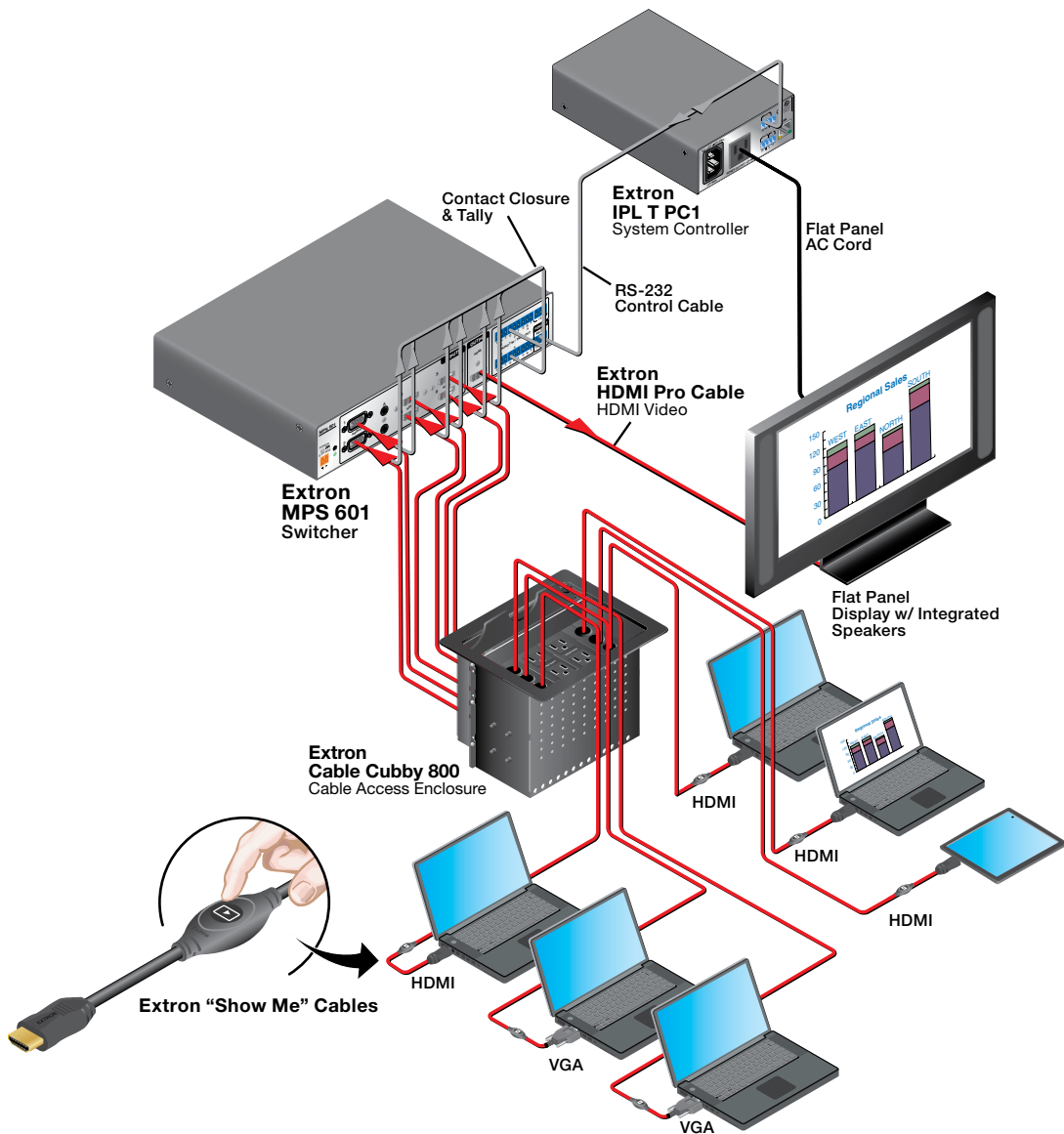

Mounting and Installation

Assembling the Cable Cubby

1. Install the power modules in the Cable Cubby. The power modules that you use depend on the country you are in and the Cable Cubby model that you are using. For complete installation instructions for your Cable Cubby, see the installation guide for that Cable Cubby, which is available at www.extron.com.

WARNING: Possible electric shock: To ensure good electric grounding, you must secure the power modules to the Cable Cubby using screws with star washers.

2. Assemble the AAP shelf assembly and “Show Me” cables.

The AAP shelf assembly components will depend on the Cable Cubby you are using. Follow the instructions in the Cable Cubby installation guide.

ATTENTION: The “Show Me” cables must be integrated into the AAP shelf assembly as it is being put together. Ensure that they are installed in the correct orientation:

- The end with the button and LED connects to the input devices and must come out of the top of the Cable Cubby.
- The end with the three-conductor pigtail connects to the switcher and must come out of the bottom of the Cable Cubby.

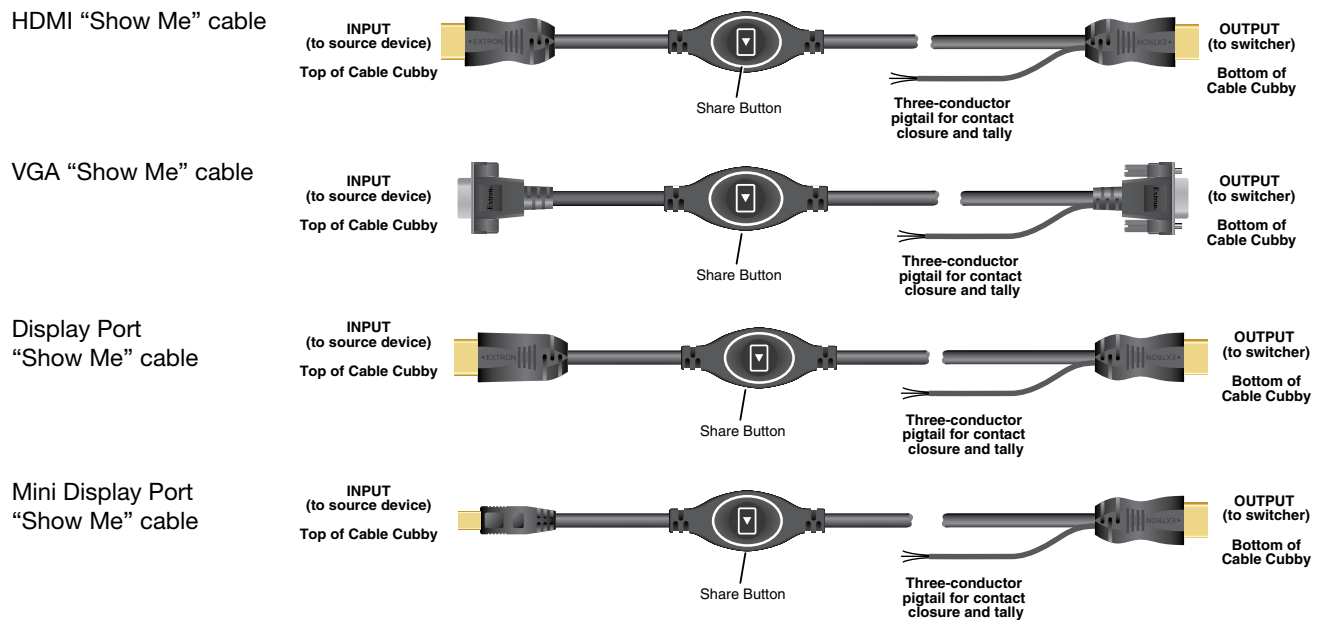

3. Insert the AAP assemblies into the Cable Cubby from underneath and secure them in position with the provided #4-40 Phillips head screws and star washers.

Mounting and Placement of System Components

Decide where you will install your TeamWork system and where the individual components will be placed.

- The Cable Cubby should provide easy access for as many users as possible. Ensure that there is ample space for cables under the table. Ensure that the edge on which the lid opens is correctly oriented.
- The system controller should be placed close to the display.
- The switcher should be placed close to the Cable Cubby.

ATTENTION: The illustration below shows the devices mounted with the optional Extron UTS 100 and UTS 150 under-table shelf system. This is not a mounting option for all TeamWork kits, as some components are too wide to fit in the shelves.

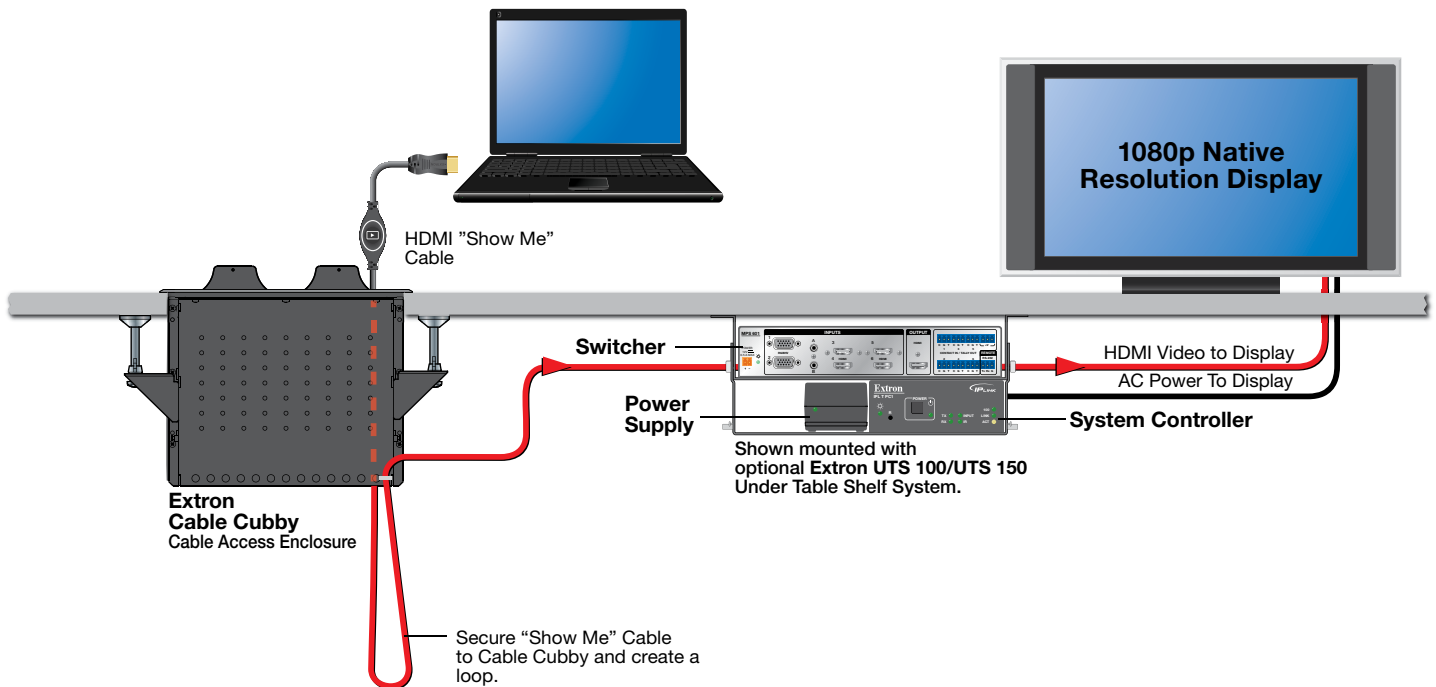

Installing the Cable Cubby in the Table

Before cutting the table and installing the Cable Cubby, see the *Cable Cubby Setup Guide* (see www.extron.com).

ATTENTION:

- Use the provided cut-out template and ensure that the orientation of the Cable Cubby and the hole dimensions are correct before cutting the table.
- After installation, secure the cables to avoid them becoming tangled (see the figure above).

Cabling

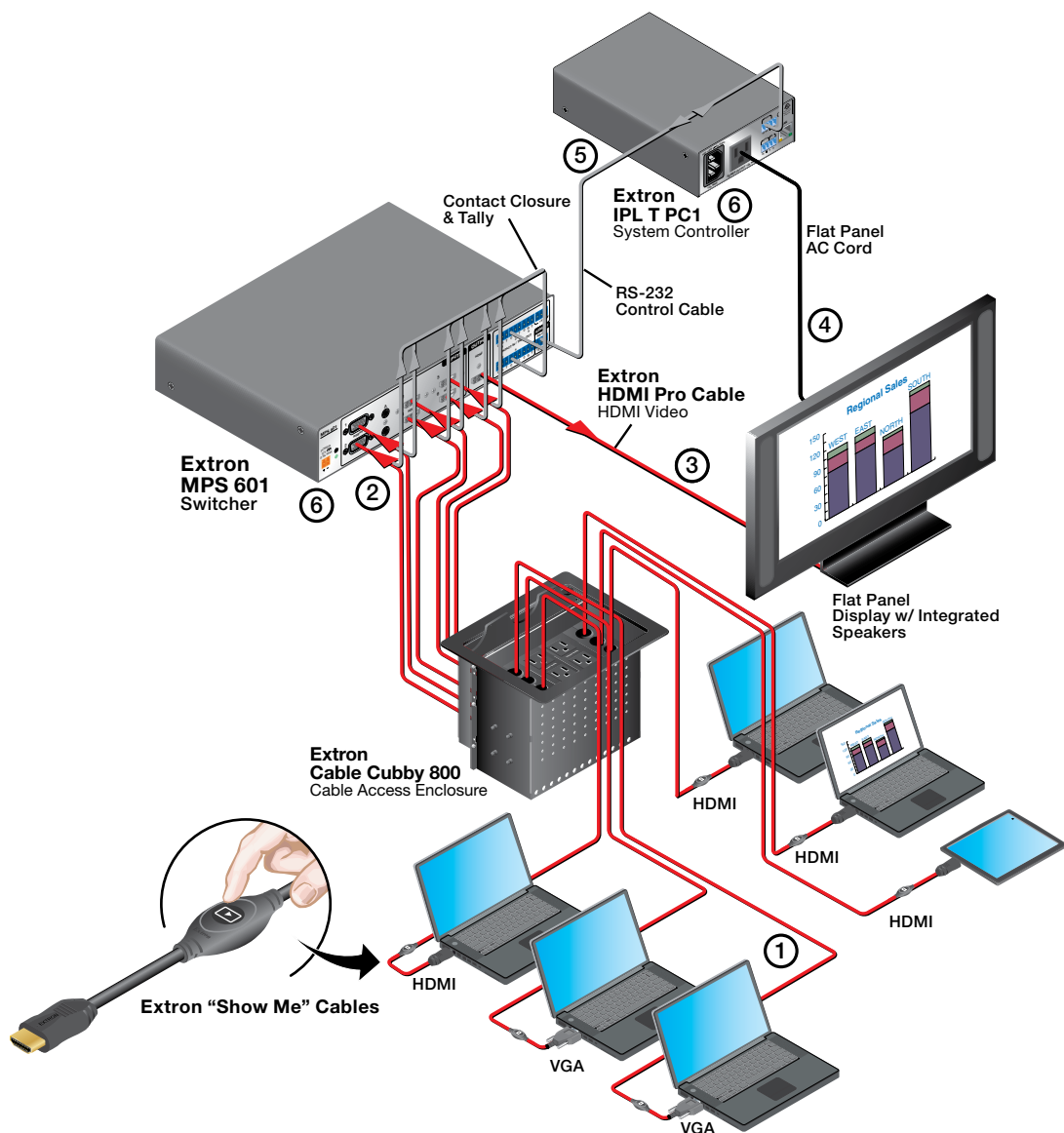

- ① Connect the “Show Me” cables to the source devices.
- ② Connect the “Show Me” cables to the switcher.

ATTENTION: If you have analog and digital video inputs, ensure that your TeamWork switcher can accept both types of signal. If not, you need the VGA TeamWork kit to convert the analog signal.

- ③ Connect the switcher to the display.
- ④ Connect the display to the system controller.

ATTENTION: The illustration above shows the IPL T PC1, which controls AC power to the display. The controller in your TeamWork kit may control the display by IR or RS-232 and connections between the controller and the display will differ from those shown above.

- ⑤ Connect the system controller to the switcher.
- ⑥ Connect power to the switcher and system controller.

“Show Me” Cables

The Extron “Show Me” cables are for use with Extron TeamWork systems. They feature a Share button for remote input source selection and a control pigtail, which may be wired directly into Extron switchers with contact closure and tally outputs. The figure below shows the HDMI “Show Me” cable, but all the “Show Me” cables have these same features (see the figure on page 2)

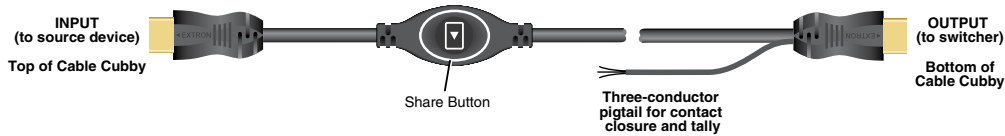

Connecting “Show Me” Cables

1. Connect the input end of the “Show Me” cable to the source device.
2. Connect the video output to the Extron switcher.

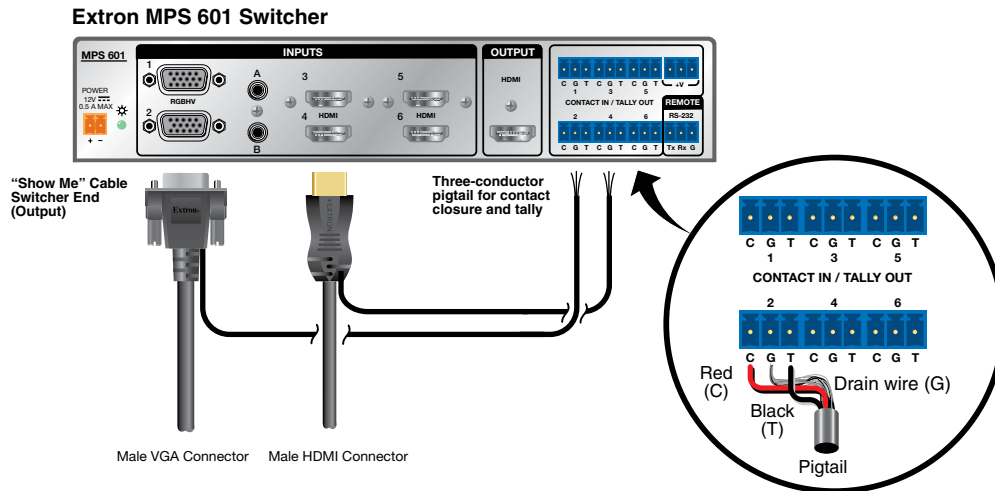

3. Connect the black (Tally Out), red (Contact In), and drain wire (ground) pigtail wires.

ATTENTION:

- The figure above illustrates how “Show Me” cables connect to the Extron MPS 601 switcher. The contact, tally out, and ground connectors may be organized differently on your switcher. Ensure the port number for the contact, tally out, and ground wires matches the video input port number. In the example above, the VGA connector is inserted into Video Input 2 and the pigtail connectors are also connected to port 2.
- The video input must be grounded. For some switchers, the “Show Me” cables are grounded via the video connectors. If this is not the case, it is necessary to connect the drain wire to the ground (G) connector.
- Do not connect the “Show Me” cable to the +V pin on the Extron switcher.

Press the Share button to switch the connected source to the main presentation display.

Pressing the Share button creates a momentary contact closure, which triggers the switcher to select the connected source device. If a tally output is available, the button will light up blue.

NOTES:

- The source device provides the +5 VDC supply voltage needed to illuminate the Share button. If the source device does not supply this +5VDC, the Share button will not illuminate. Some mobile devices do not provide the required voltage to light up the button.
- Digital “Show Me” cables support embedded audio and CEC signals.

Connect the Switcher to the Display Device

Connect the switcher HDMI output to the HDMI input of the display device, using the provided cable. Do not use HDMI to DVI adapters. If necessary, see the user guide for the display device.

TeamWork • Installation Guide (Continued)

System Controller

The display and switcher in your system may be controlled by RS-232, Ethernet, or IR, depending on the models. The IPLink control processor must be configured to communicate correctly with the display and switcher. See the user guide for the controller for complete instructions about configuration. The guide is available at www.extron.com.

Connect the Display to the System Controller

Before connecting the controller to the display, see the user guide for that device. The guide is available at www.extron.com.

ATTENTION: If you are using the IPL T PC1i (International TeamWork kits) you must replace the power plug on the display with the provided adapter (see [IEC C14 Male Power Cord Plug Installation](#) on page 8).

Connect the System Controller to the Switcher

To connect the system controller to the switcher, you may need to make your own control cable.

The required captive screw connector is provided with each unit. The exact size (3-pole, 4-pole, or 5-pole) depends on the unit. Although the number of wires that the connector can take varies, only three poles are required in each case: Tx, Rx, and ground. In the figure below, the 4-pole COM port of the IPL T PC1 controller connects to the 3-pole RS-232 port of the MPS 601 switcher.

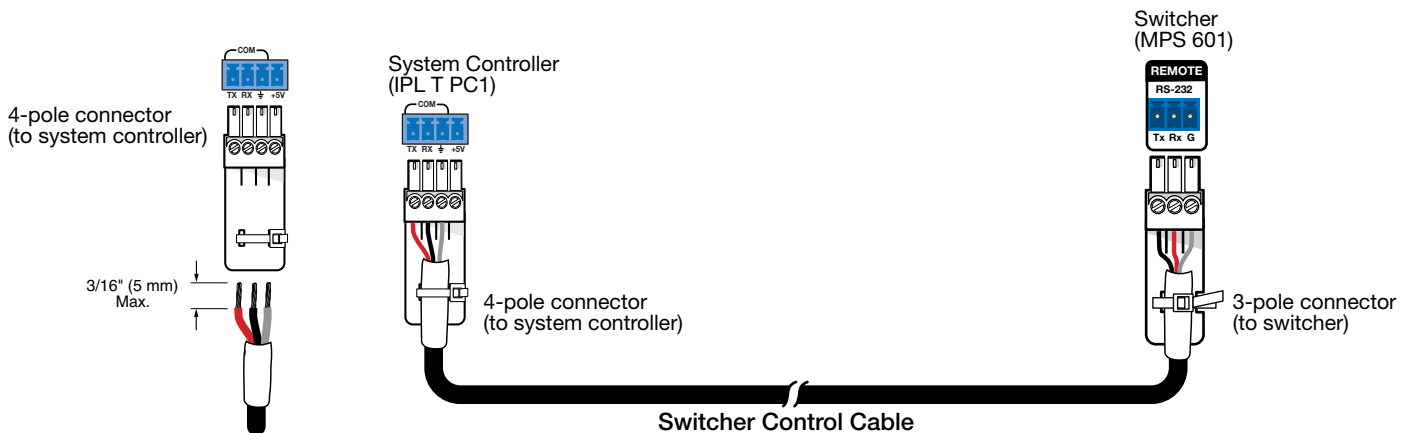

To make a control cable:

1. Strip the outer sheath from each end of the control cable to expose about 1 inch of the three wires.
2. Strip 3/16 inch of the sheath from each individual wire.
3. On the captive screw connector provided with the controller, identify which pins correspond to Tx, Rx, and ground on the controller COM port.
4. Connect the three wires from one end of the control cable to the Tx, Rx, and ground pins of the captive screw connector.
5. On the captive screw connector provided with the switcher, identify which pins correspond to Tx, Rx, and ground on the RS-232 port of the switcher.
6. Connect the three wires from the other end of the control cable as follows:
 - Controller Tx connects to switcher Rx
 - Controller Rx connects to switcher Tx
 - Controller ground connects to switcher ground
7. Secure the control cable to the captive screw connectors at both ends using the cable tie provided.

Connect Power

If the device has an internal power supply, connect the power cord to a wall outlet.

If the device requires a power supply, connect the power supply provided to the device.

ATTENTION: Do not connect any external power supplies until you have read the Attention notifications in the "Power Supply" section of the user guide for that device.

Addendum

This section provides additional information about the specific requirements of the IPL T PC1 and IPL T PC1i controllers.

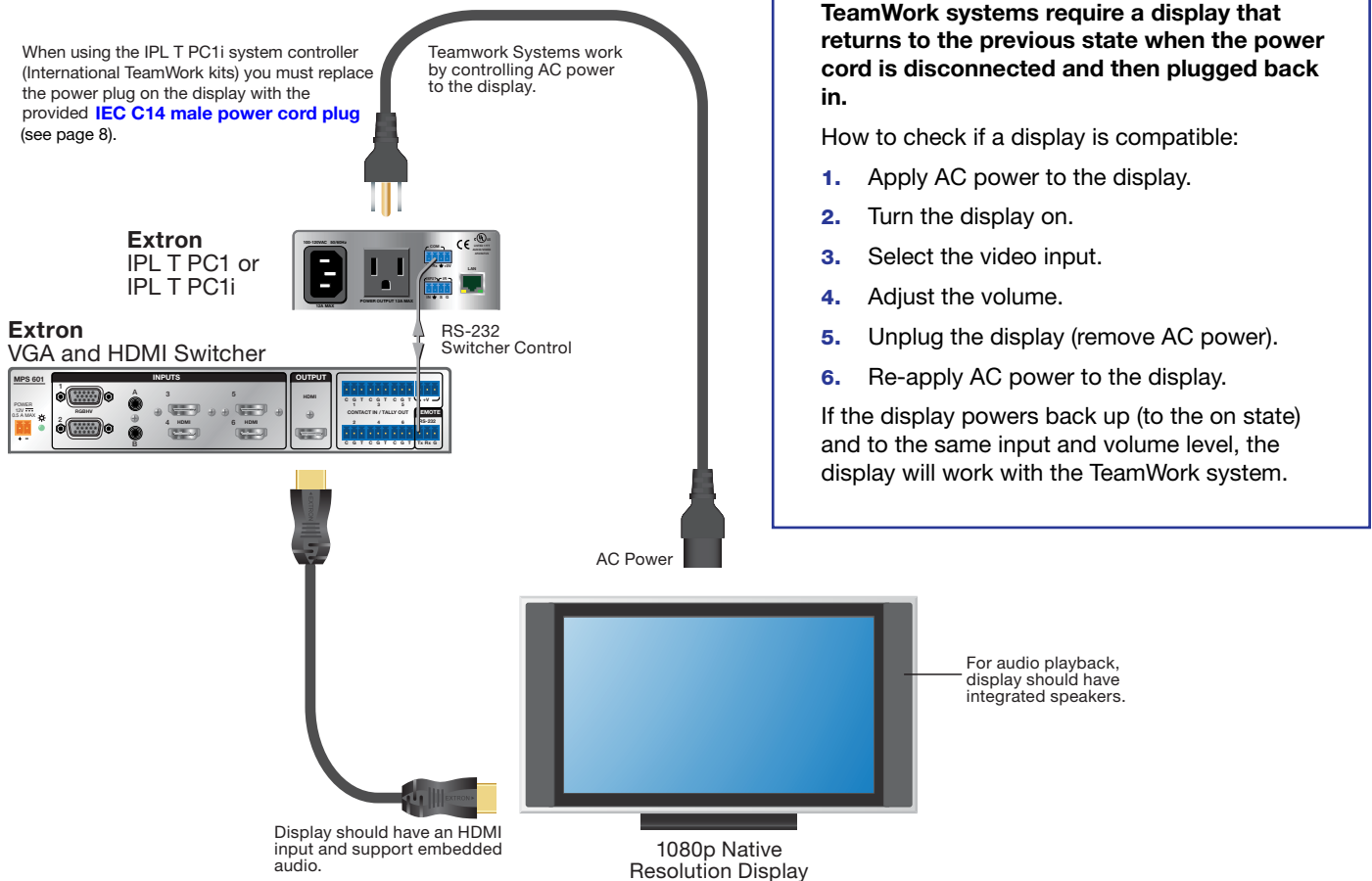

Display Requirements for the IPL T PC1 and IPL T PC1i

ATTENTION: This section applies to the IPL T PC1 and the IPL T PC1i, which controls the AC power to the display. If a different controller is used, it needs to be configured differently (see the user guide for the controller at www.extron.com).

The TeamWork system works with most brands and models of flat panel displays available worldwide. For optimum performance, consider the following when selecting the displays for your TeamWork installation. The display should be tested thoroughly prior to installation or mass deployment of TeamWork systems.

Power attributes — The IPL T PC1 works by controlling AC power to the display. When the display is in the on state with an HDMI input selected, it must be able to power back on to the same HDMI input when AC power is disconnected and reconnected. If the display doesn't behave this way, an alternate display should be used. Alternatively, you may need to control the display a different way (for example RS-232, infrared, or via Ethernet) using a different type of Extron control processor.

Sleep mode — if the display has a sleep mode feature (sometimes called 'auto sleep'), it must be disabled. Many displays have an option to disable this within the menu settings.

Resolution — The TeamWork systems were designed for use with flat panels having an HDMI input connector and having a native resolution of 1080p. Many of the readily available consumer and professional displays support 1080p natively.

Audio — Audio from source devices is supported in the TeamWork system by routing it as an embedded audio signal to the display for playback via integrated speakers. Most displays with HDMI inputs and integrated speakers work this way. Some professional or commercial grade displays do not have integrated speakers and will not support audio playback. Typically, source devices with HDMI output connectors embed audio onto the HDMI connector.

NOTES:

- Always check and test compatibility before installation. Some systems may require advanced configuration of the system controller and require the display to be controlled by RS-232, Ethernet, or infrared.
- Some displays support a lockout of local buttons. Extron recommends that, after setup, user accessible controls are locked whenever possible. This ensures the display remains optimized for the TeamWork system.

IEC C14 Male Power Cord Plug Installation

When using the IPL T PC1i system controller (International TeamWork kits) you must replace the power plug on the display with the provided IEC C14 male power cord plug. This plug has a maximum current rating of 10 A and a maximum voltage of 250 VAC.

WARNING: High Voltage. Failure to follow these instructions may result in serious injury.

- Installation and service of the power cord plug must be performed by authorized personnel only.
- Observe the correct wire polarity.
- Before installation, disconnect the display from the power source or any other device.

NOTE: The power cord plug shown in the figure is for illustration only. The plug provided may not look exactly the same.

1. Cut the existing plug from the power cord.
2. Remove a suitable amount of the outer sheath from the power cord. Individual wires should not extend from the back of the strain relief after the plug is installed.
3. Strip a suitable amount of the jacket from the three wires. There should be just enough bare metal to wrap around the screw in step 7.
4. Loosen the screw and remove the top plate.
5. If required, loosen the white plastic wire clamp.
6. Thread the cord through the strain relief.
7. Use a flat head screwdriver to secure the individual wires to the correct connector.

WARNING: Observe the correct wire polarity (see the diagram to the left).

8. Secure the wires by tightening the white plastic wire clamp.
9. Reattach the top plate and screw that were removed in step 4.

Extron Headquarters +1.800.633.9876 (Inside USA/Canada Only) Extron USA - West Extron USA - East +1.714.491.1500 +1.919.850.1000 +1.714.491.1517 FAX +1.919.850.1001 FAX	Extron Europe +800.3987.6673 (Inside Europe Only) +31.33.453.4040 +31.33.453.4050 FAX	Extron Asia +65.6383.4400 +65.6383.4664 FAX	Extron Japan +81.3.3511.7655 +81.3.3511.7656 FAX	Extron China +86.21.3760.1568 +86.21.3760.1566 FAX	Extron Middle East +971.4.299.1800 +971.4.299.1880 FAX	Extron Korea +82.2.3444.1571 +82.2.3444.1575 FAX	Extron India 1800.3070.3777 (Inside India Only) +91.80.3055.3777 +91.80.3055.3737 FAX
--	--	--	---	---	---	---	--