

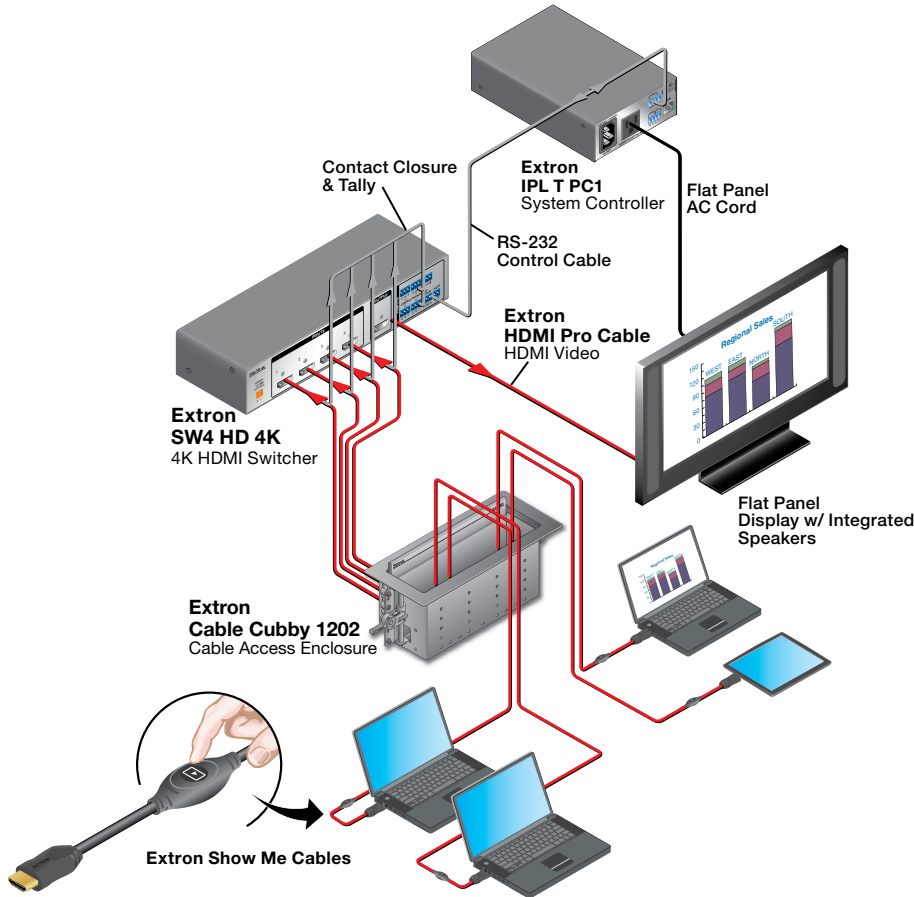

TeamWork® Kits • Installation Guide

TeamWork 400 and TeamWork 600 Kits

The TeamWork 400 and TeamWork 600 kits consist of an HDMI switcher, system controller, Cable Cubby®, and cables packaged together as a complete system that, in most cases, requires no configuration.



The diagram above shows a typical TeamWork 400 application. Teamwork 600 applications are similar but use different switcher and Cable Cubby models. Input devices (laptops and a tablet) connect to the switcher, using Show Me® cables, which allow the user to select the active input on the switcher. A control cable connects the RS-232 ports on the switcher and the system controller.

The system controller powers the display on and off. The system controller has been configured so that when a video signal is detected on any of the switcher inputs, the display is powered on. A 30-second timer is started when no signal is detected on any of the switcher inputs. If an active source is detected before the timer expires, the display remains on and the timer is reset. If 30 seconds pass without an active signal, the system controller powers off the display.

The TeamWork kit works, as described, without further software configuration. If you need to change the behavior or operation of the system, you must configure the system controller (see the *IPL T PC1/IPL T PC1i User Guide* at www.extron.com).

TeamWork VGA Kit (Optional)

The TeamWork VGA kit adds support for legacy analog computer sources to the TeamWork 400 and TeamWork 600 collaboration systems. For fast installation, the analog-to-digital converter (RGB-HDMI 300 A) is pre-configured for use with flat panel displays that have a resolution of 1080p. If you need to change the behavior or operation of the converter, see the *RGB-DVI 300 and RGB-HDMI 300 (A) User Guide* at www.extron.com.

NOTE: The RGB-HDMI 300 A is pre-configured to lock out the front panel buttons. To enable or disable front panel security lockout, press and hold the **Menu** and **Enter** buttons simultaneously for two seconds.

TeamWork Kits • Installation Guide (Continued)

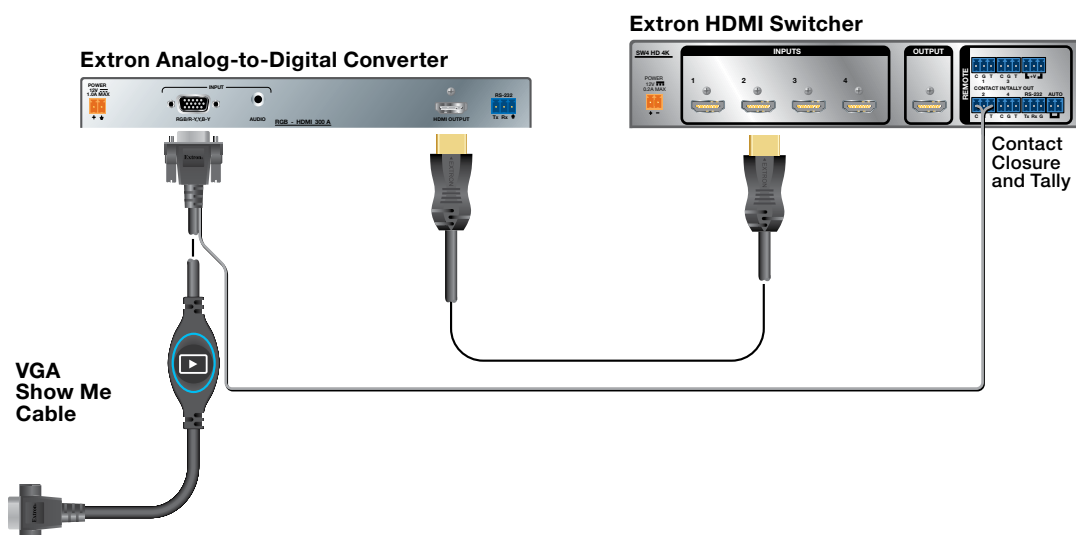

Features

- Standard systems support groups of up to four (TeamWork 400) or six (TeamWork 600) users.
- Standard systems contain a complete turnkey package that includes cables, switcher, system controller, and Cable Cubby enclosure.
- System controller pre-loaded with Global Configurator that requires no further adjustment.
- Works with most commercially available flat panel displays, laptops and tablets.
- HDCP compliant
- Supports legacy analog sources with optional TeamWork VGA kit.
- Section 508 compliant.

Kit Components

When your kit is delivered, check that all the components are present.

TeamWork 400 and TeamWork 600 Kits

	TeamWork 400	TeamWork 600
HD 4K switcher	1 (SW4 HD 4K, 4 inputs)	1 (SW6 HD 4K, 6 inputs)
System controller	1 (IPL T PC1)	1 (IPL T PC1)
Cable Cubby	Cable Cubby 1202	Cable Cubby 1402
Power modules (included with the Cable Cubby)	1	2
HDMI Show Me cables	4	6
HDMI cable	1	1
Switcher control cable	1	1
8-cable Cable Cubby Bracket Kit	1	2
Installation Guide	<i>TeamWork Kits Installation Guide</i>	

TeamWork VGA Kit (Optional)

	TeamWork VGA
Analog-to-digital converter	1 (RGB-HDMI 300 A)
VGA Show Me cable	1
HDMI cable	1
Installation Guide	<i>TeamWork Kits Installation Guide</i>

TeamWork Kits • Installation Guide (Continued)

Display Requirements

The TeamWork system is designed to work with most brands and models of flat panel displays available worldwide. For optimum performance, consider the following when selecting the displays for your TeamWork installation. The display should be tested thoroughly prior to installation or mass deployment of TeamWork systems.

Power attributes — The system works by controlling AC power to the display. When the display is in the ON state with an HDMI input selected, it must be able to power back ON to the same HDMI input when AC power is disconnected and reconnected. If the display doesn't behave this way, an alternate display should be used. Alternatively, you may need to control the display a different way (i.e. RS-232, infrared, or via Ethernet) using a different type of Extron control processor.

Sleep mode — if the display has a Sleep Mode feature (sometimes called 'auto sleep'), it must be disabled. Many displays have an option to disable this within the menu settings.

Resolution — The TeamWork systems were designed for use with flat panels having an HDMI input connector. For a full list of supported resolutions, please refer to the product specifications at www.extron.com.

Audio — Audio from source devices is supported in the TeamWork system by routing it as an embedded audio signal to the display for playback via integrated speakers. Most displays with HDMI inputs and integrated speakers work this way. Some professional or commercial grade displays do not have integrated speakers and will not support audio playback. Typically, source devices with HDMI output connectors embed audio onto the HDMI connector.

NOTES:

- Always check and test compatibility before installation. Some systems may require advanced configuration of the system controller and require the display to be controlled by RS-232, Ethernet, or Infrared.
- Some displays support a lockout of local buttons. Extron recommends that, after setup, user accessible controls are locked whenever possible. This ensures the display remains optimized for the TeamWork system.

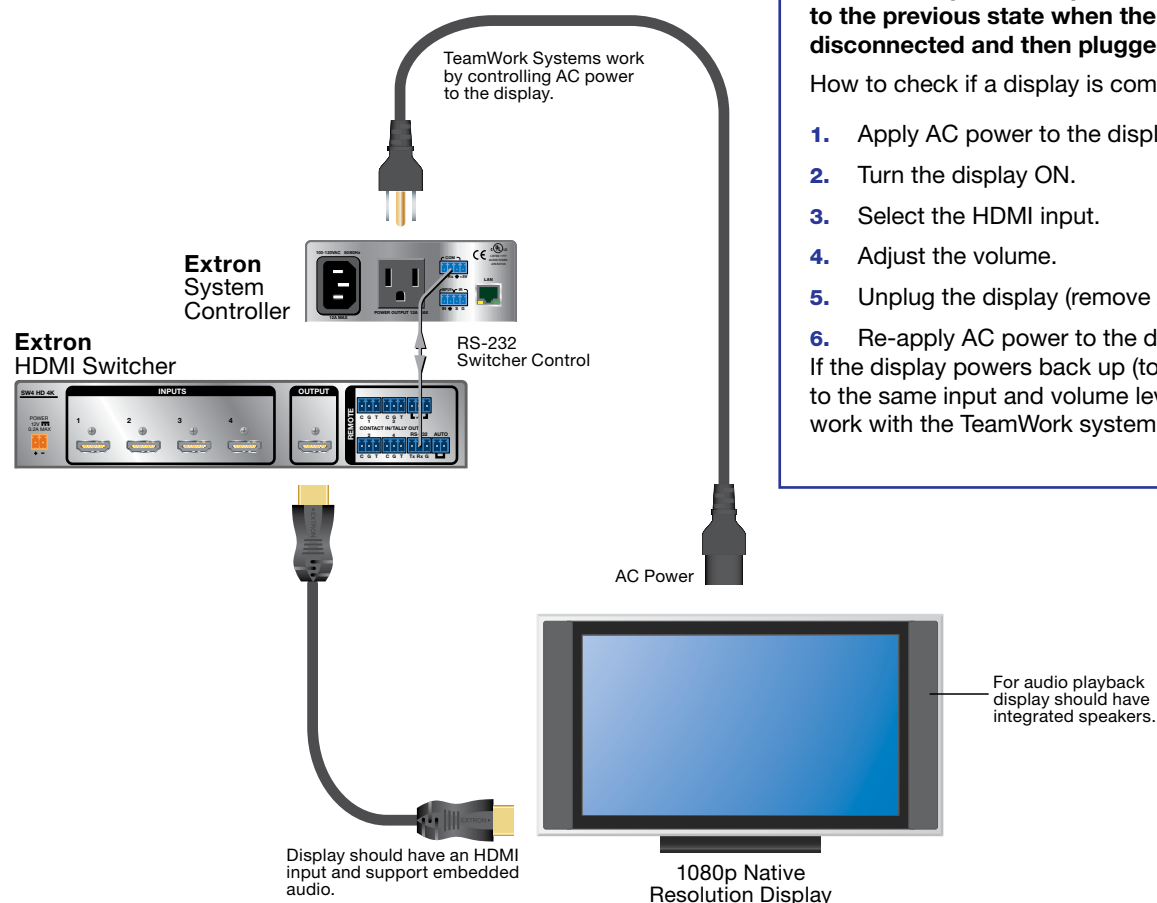

TeamWork systems require a display that returns to the previous state when the power cord is disconnected and then plugged back in.

How to check if a display is compatible:

1. Apply AC power to the display.
2. Turn the display ON.
3. Select the HDMI input.
4. Adjust the volume.
5. Unplug the display (remove AC power).
6. Re-apply AC power to the display. If the display powers back up (to the ON state) and to the same input and volume level, the display will work with the TeamWork system.

Installation

Install the Module Assemblies and Show Me Cables

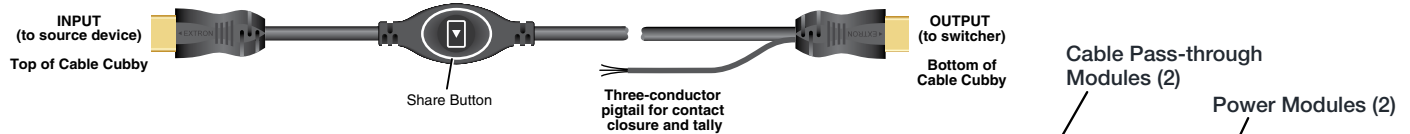

ATTENTION:

- The end with the button and LED connects to the input devices and must come out of the top of the Cable Cubby.
- Le bout avec le bouton et la LED se connecte aux appareils d'entrée et doit ressortir du haut du Cable Cubby.
- The end with the three-conductor pigtail connects to the switcher and must come out of the bottom of the Cable Cubby.
- Le bout avec le mini câble à trois conducteurs se connecte au sélecteur et doit ressortir du bas du Cable Cubby.

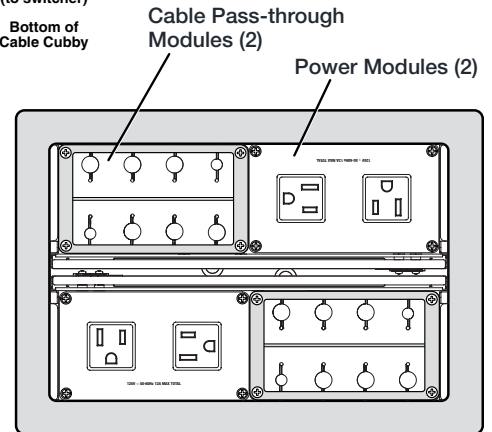

The Cable Cubby 1202 can accommodate two modules, side by side. The Cable Cubby 1402 can accommodate four modules (see the figure at top right). Detailed information is in the *Cable Cubby Setup Guide*.

1. Assemble the cable pass-through cassette module as shown in the diagram to the right (1, 2, and 3).
2. Insert the cable cassette module into the Cable Cubby from underneath (4) and secure them in position with the provided #4-40 Phillips head screws and star washers.

NOTE: The diagrams on this page show HDMI Show Me cables in the cable cassette module. If you are using the TeamWork VGA kit, install VGA Show Me cables in exactly the same way.

- 2 Attach the Show Me Cable Trim Plate to the top of the module, using the provided module screws (4).

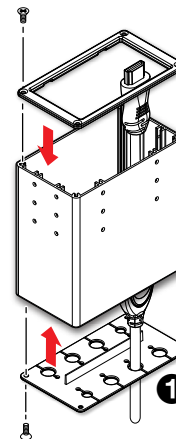

- 3 Attach the grommet plate to the bottom of the module, using the provided module screws (4).
- 1 Insert Show Me Cables into the grommet plate.

Install the Power Modules in the Cable Cubby

Insert the power module into the Cable Cubby from underneath and secure the power modules in position with the provided #4-40 Phillips head screws and star washers (5).

⚠️ WARNING: Possible electric shock: To ensure good electric grounding, you must use the star washers with the screws.

AVERTISSEMENT: Risque de choc électrique: Afin d'assurer une mise à la terre correcte, vous devez fixer les modules d'alimentation au Cable Cubby à l'aide de vis et de rondelles en étoile.

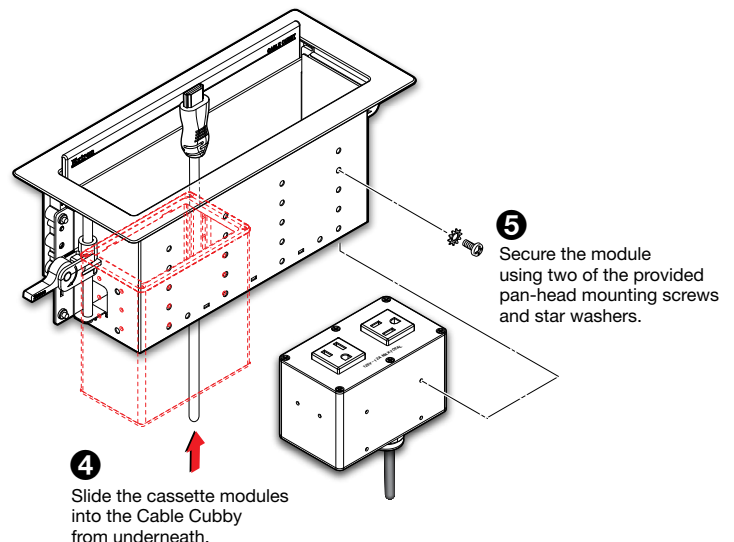

TeamWork Kits • Installation Guide (Continued)

Mounting and Placement of System Components

Decide where to install your TeamWork system and where to place the individual components.

- 1 The Cable Cubby should provide easy access for as many users as possible. Ensure that there is ample space for cables under the table. Ensure that the edge on which the lid opens is correctly oriented.
- 2 The system controller should be placed close to the display.
- 3 The SW4 HD 4K (or SW6 HD 4K) switcher should be placed close to the Cable Cubby.
- 4 The analog-to-digital converter (with the optional TeamWork VGA kit) should be placed next to the switcher. Ensure that the VGA connector can connect to the converter and that the three-conductor pigtail can connect to the switcher.

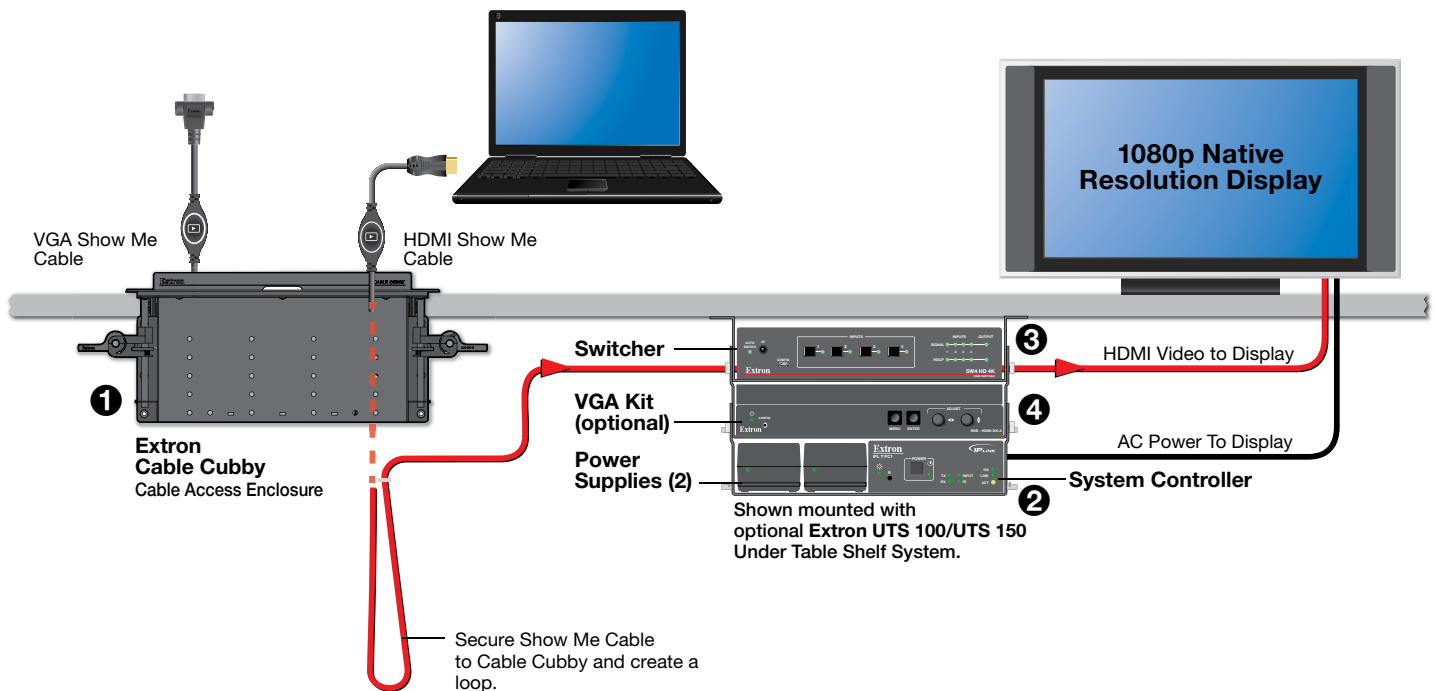

Installing the Cable Cubby in the Table

Before cutting the table and installing the Cable Cubby, see the *Cable Cubby Setup Guide* (see www.extron.com).

ATTENTION:

- Ensure that the orientation of the cable cubby and the hole dimensions are correct before cutting the table.
- Assurez vous que la position du Cable Cubby et les dimensions du trou soient correctes avant de couper la table.
- After installation, secure the cables to avoid them becoming tangled (see the figure above).
- Après l'installation, sécurisez les câbles de façon à éviter qu'ils ne s'emmêlent (voir l'illustration au-dessus).

TeamWork Kits • Installation Guide (Continued)

Cabling

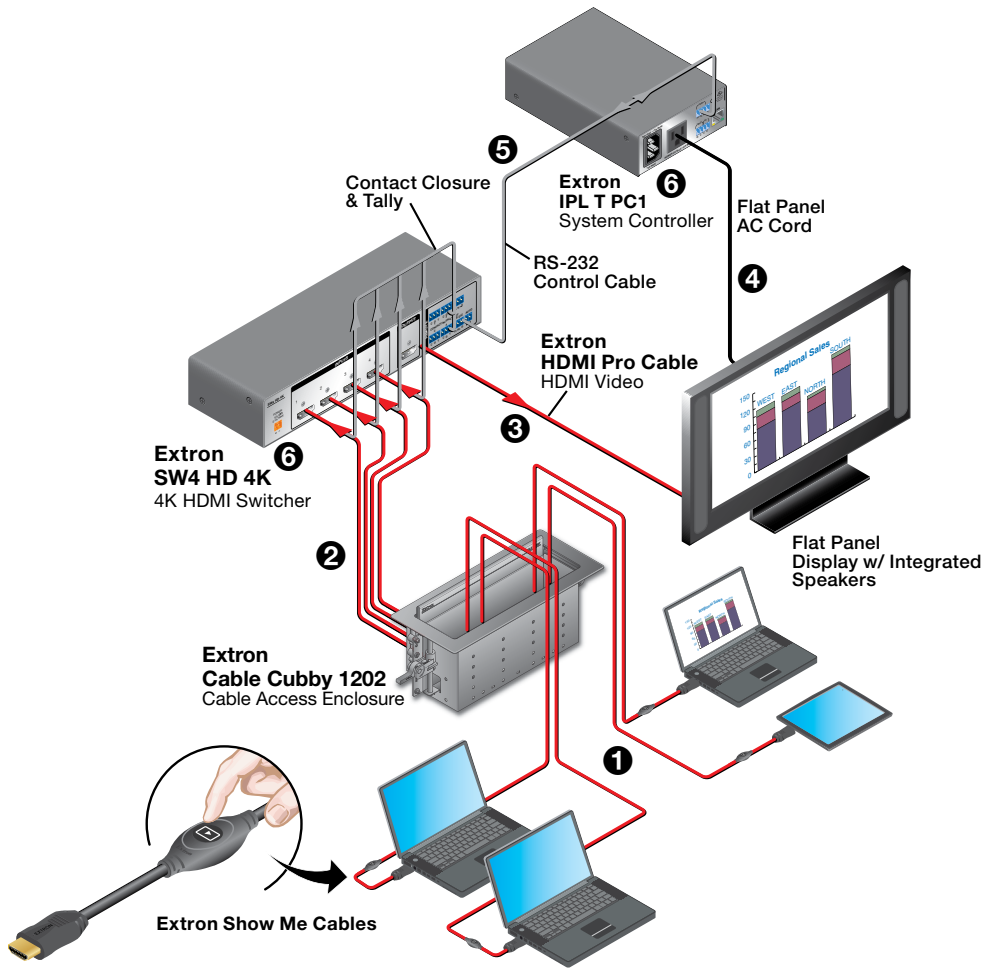

- ❶ Connect the Show Me cables to the source devices.
- ❷ Connect the Show Me cables to the switcher.
- ❸ Connect the switcher to the display.
- ❹ Connect the display power cable to the system controller.
- ❺ Connect the system controller to the switcher.
- ❻ Connect power to the switcher and system controller.

This diagram shows the TeamWork 400 system. To add a TeamWork VGA kit to the TeamWork system, see [VGA Show Me Cables](#) on page 8.

TeamWork Kits • Installation Guide (Continued)

Show Me Cables

The Extron Show Me cables are for use with Extron TeamWork systems. They feature a **Share** button for remote input source selection and a control pigtail, which may be wired directly into Extron switchers with contact closure and tally outputs.

HDMI Show Me cable

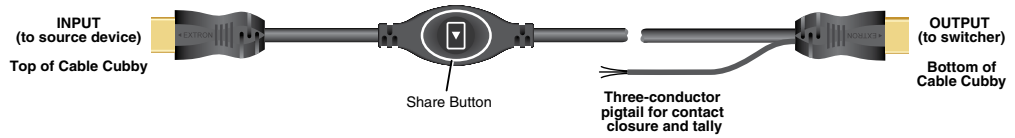

VGA Show Me cable

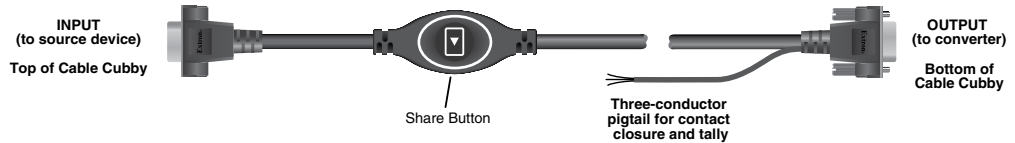

HDMI Show Me Cables

1. Connect the input end of the Show Me cable to the source device.
2. Connect the HDMI output to the Extron switcher.
Extron SW4 HD 4K Switcher (HDMI input)

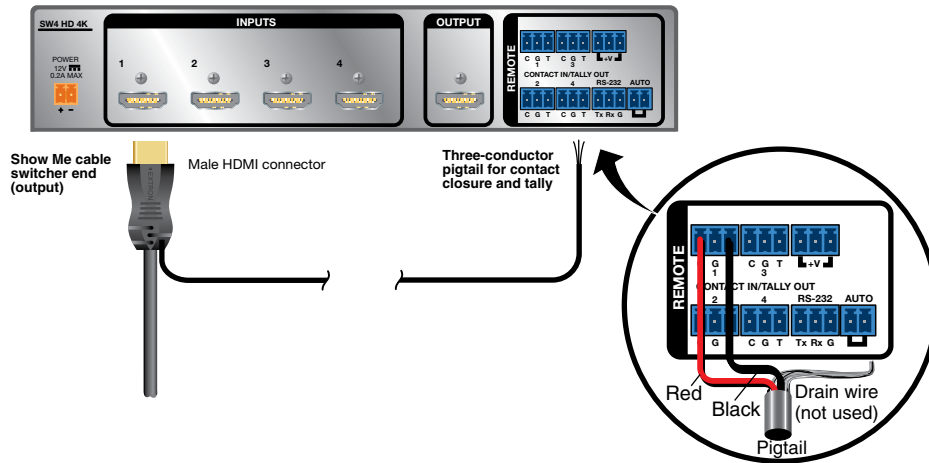

3. Connect the black (Tally Out) and red (Contact) pigtail wires as shown above. The number above the Tally Out (T) and Contact (C) pins must correspond to the video input on the switcher.

NOTES:

- The drain wire does not need to be wired to the switcher. The Show Me cables are grounded via the video connectors.
- Do not connect the Show Me cable to the +V pin on the Extron switcher.

Press the **Share** button to switch the connected source to the main presentation display.

Pressing the **Share** button creates a momentary contact closure, which triggers the switcher to select the connected source device. If a tally output is available, the button will light up blue.

NOTES:

- The source device provides the +5 VDC supply voltage needed to illuminate the **Share** button. If the source device does not supply this +5VDC, the **Share** button will not illuminate. Some mobile devices do not provide the required voltage to light up the button.
- Digital Show Me cables support embedded audio and CEC signals.

TeamWork Kits • Installation Guide (Continued)

VGA Show Me Cables

1. Connect the input end of the VGA Show Me cable to the source device.
2. Connect the output of the Show Me cable to the VGA input of the analog-to-digital converter.
3. Connect the HDMI cable from the digital output of the converter to the HDMI input of the switcher.

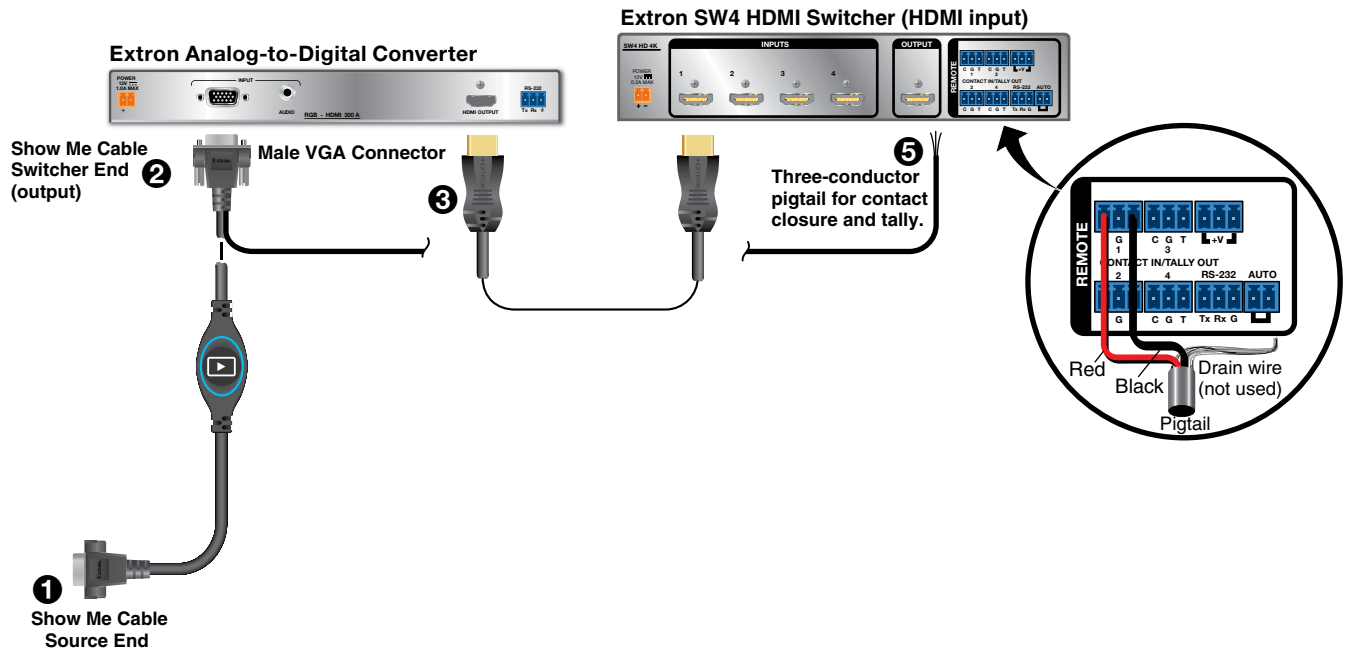

4. (Optional) Connect the audio output from the source device to the 3.5 mm TRS audio input on the converter (the cable is not provided with the TeamWork VGA kit). The audio signal is embedded in the HDMI output signal.
5. Connect the black (Tally Out) and red (Contact) pigtail wires as shown above. The number under the Tally Out and Contact pins must correspond to the video input on the switcher.

NOTES:

- The drain wire does not need to be wired to the switcher. The Show Me cables are grounded via the video connectors.
- Do not connect the Show Me cable to the +V pin on the Extron switcher.

Press the **Share** button to switch the connected source to the main presentation display.

Pressing the **Share** button creates a momentary contact closure, which triggers the switcher to select the connected source device. If a tally output is available, the button will light up blue.

NOTE: The source device provides the +5 VDC supply voltage needed to illuminate the **Share** button. If the source device does not supply this +5 VDC, the **Share** button will not illuminate. Some mobile devices do not provide the required voltage to light up the button.

TeamWork Kits • Installation Guide (Continued)

Connect the Switcher to the Display Device

Connect the switcher HDMI output to the HDMI input of the display device, using the provided cable. If necessary, see the user guide for the display device.

Connect the Display to the System Controller

Connect the power cord from the display device to the power output receptacle of the system controller. TeamWork systems work by controlling the AC power to the display.

Connect the System Controller to the Switcher

Connect the COM port of the system controller to the RS-232 port on the switcher with the provided control cable.

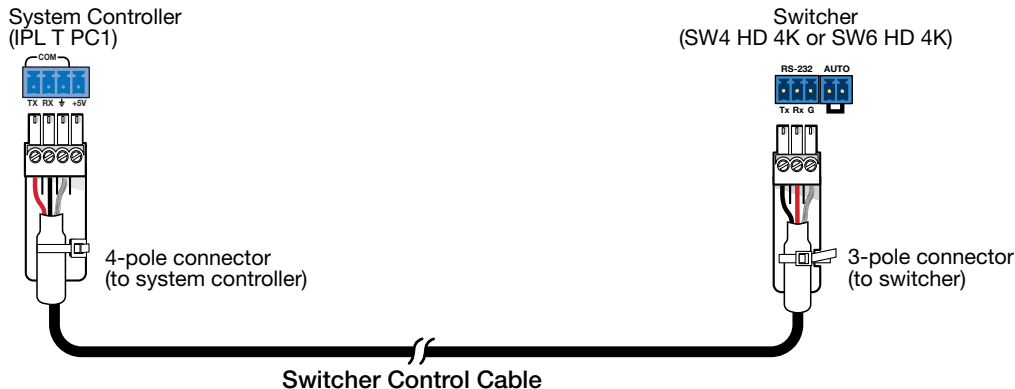

ATTENTION:

- The two ends of the RS-232 control cable are different. One has a 4-pole connector, the other has a 5-pole connector.
- Les deux terminaisons du câble de contrôle RS-232 sont différentes. L'une a un connecteur 4 pôles, l'autre a un connecteur 3 pôles.

Connect Power

The system controller uses an internal power supply. Connect the power cord to a wall outlet.

The TeamWork 600 systems use a 6-input switcher with an internal power supply. Connect the power cord to a wall outlet.

The TeamWork 400 systems use a 4-input switcher with a 12 VDC, 1.5 A power supply, which is provided with the switcher.

ATTENTION:

- Do not connect the power supply to the SW4 HD 4K switcher until you have read the Attention notifications in the "Wiring the Power Supply" section of the *SW HD 4K Series User Guide*.
- Ne branchez pas le sélecteur SW4 HD 4K avant d'avoir lu la mise en garde dans la section « sources d'alimentation » du *SW HD 4K Series User Guide*.

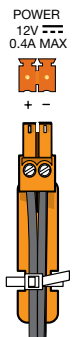

The optional TeamWork VGA kit also includes a 12 VDC, 1.5 A power supply for the analog to digital converter.

TeamWork Kits • Installation Guide (Continued)

Converter SIS™ Commands

The following features have been pre-configured on the RGB-HDMI 300 A. The values should be re-entered if they have been erased by a factory reset (see the *RGB-DVI 300 and RGB-HDMI 300 (A) User Guide* at www.extron.com for a complete explanation of SIS commands).

Feature	SIS Command
Set output signal resolution to 1080p	[Esc] 24*8RATE ←
Enable power save mode	[Esc] 1PSAV ←
Enable Auto-Image	1*1A
Disable auto memories	[Esc] ØAMEM ←
Enable front panel security lockout	1X

[Esc] = Escape key

← = Carriage return (no line feed)

Testing the System

The TeamWork system has been pre-configured so that, once all the connections have been made and the devices are all powered on, there should be no need of further configuration for the system to work. To ensure that the system has been set up correctly, follow these steps:

1. Power on the equipment
 - Source devices
 - Switcher
 - System controller (IPL T PC1)
2. Press the **Power** button (❶) on the front panel of the system controller. The LED (❷) lights green when power is being supplied to the attached output device.
3. Turn on the display and confirm that the display is receiving power.
4. Go to the menu for the display and disable the Sleep Mode feature. If necessary, see the user guide for the display.
5. Press the power button on the power controller. The LED should go out and the display should be turned off.
6. Connect one of the Show Me cables to a video source, such as a laptop.
7. Press the **Show Me** button on that cable. If the source device is providing a video signal, the LED on the Show Me cable lights blue and the display automatically turns on.
8. Connect a second Show Me cable to a second video source.
9. Repeat step 7 to verify that the second source device is providing a video signal and it is the output signal from the switcher. When the button on the second Show Me cable is pressed, the LED lights blue and the LED on the first cable is switched off.
10. Disconnect all the Show Me cables from the source devices. After about 30 seconds without an input signal, the display should turn off.
11. Connect a Show Me cable to a source device and press the **Show Me** button on that cable. As soon as an active video signal is detected, the display should automatically turn on.

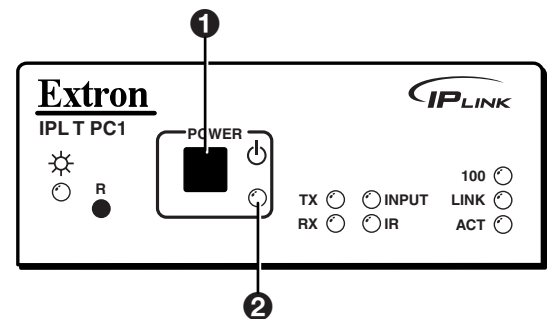

Troubleshooting

No Image on the Display:

Cause 1 — There is a problem with the source device:

Solution — Verify that the source device is powered **on** and outputs an active signal.

Cause 2 — Cable connections are incorrect:

Solution — Verify that the HDMI output cable from the switcher is connected to the current HDMI input of the display.

Cause 3 — Display is off:

Solution 1 — Verify that the display is in the **on** state.

Solution 2 — The TeamWork system turns the display on and off by controlling the AC power. If the display has a Sleep Mode feature, this feature must be disabled to prevent the display from accidentally powering **off**.

TeamWork Kits • Installation Guide (Continued)

Cause 4 — The display has a problem:

Solution — Verify that the display functions correctly.

Cause 5 — The display cannot show video at the incoming resolution:

Solution — The EDID settings on the switcher may need to be changed. Refer to the *SW HD 4K Series User Guide* (see www.extron.com) or contact an Extron Support representative at www.extron.com/company/contactus.aspx.

Show Me Button LEDs Stay Off When Pressed:

Cause 1 — The cable is not plugged into a source device that is producing an active video output signal:

Solution — Verify that the source device is on and producing an active signal.

Cause 2 — Contact or Tally wiring is incorrect:

Solution — See [Show Me Cables](#) (page 7) to ensure the contact and tally pins are correctly wired.

Cause 3 — The switcher is not powered on:

Solution — Verify that the switcher is powered **on**.

Cause 4 — Problem with Show Me cable:

Solution — Try connecting the video source with a different cable. If the second cable works correctly, there may be a problem with the Show Me cable. Contact Extron Support at www.extron.com/company/contactus.aspx.

Cause 5 — Problem with Switcher:

Solution — If none of the cables work correctly, there may be a problem with the switcher. Contact an Extron Support representative at www.extron.com/company/contactus.aspx.

Cause 6 — The source device does not output +5V:

Solution — This is a problem with the source device. HDMI specifications require pin 18 to carry a +5V output and VGA specifications require pin 9 to carry a +5V output.

The Display Does Not Automatically Turn On:

Cause 1 — Incorrect wiring:

Solution — Verify that the RS-232 communication cable is connected properly between the IPLink controller and Extron switcher.

Cause 2 — There is no video signal present at Show Me cables:

Solution — Verify that an active signal is present at the input of any of the Show Me cables.

Cause 3 — IPLink configuration on the system controller is missing or corrupted:

Solution — Contact an Extron Support representative at www.extron.com/company/contactus.aspx.

Cause 4 — Display power is out of sync:

Solution — The display is in standby mode. Turn on the display using the remote or the physical power button.

Cause 5 — Display has sleep mode enabled

Solution — Go to the menu for the display and disable the sleep mode feature. Turn on the display using the remote or physical power button.

The Display Stays On and Never Turns Off:

Cause 1 — Video signal is present at Show Me cables:

Solution — Verify that no active signals are present at the inputs of any of the Show Me cables. The TeamWork system is designed to turn off the Display only when no video signals are present.

