

The Extron ACP 105 EU/MK Audio Control Panel is a fully configurable control interface for use with any Extron ACP-enabled device.

Each ACP 105 EU/MK includes two ACP ports, which support power and communication between the host device and the ACP 105 EU/MK. Up to eight ACP panels can be used per host device for more demanding control needs.

NOTE: The ACP 105 EU front and rear panels are identical to those of the ACP 105 MK. The only difference is the shape of the plastic faceplate attached to the front of the device. The panels function identically.

Planning System Installation

When planning an ACP system installation, consider how many ACP panels to use, maximum cable distance, and mounting (see the ACP 105 EU and ACP 105 MK product pages at www.extron.com for more information regarding the ACP 105 EU/MK).

Front and Rear Panel Features

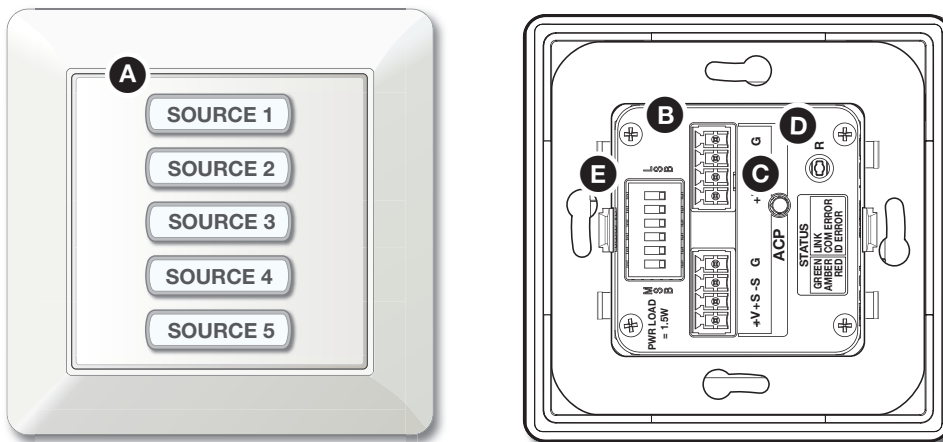

Figure 1. ACP 105 EU/MK

- A** Front Panel Buttons
- B** ACP Ports (2)
- C** Connection Status LED
- D** Reset Button
- E** Bus ID DIP Switches

Installation

Step 1: Get Ready

Use the following checklist to prepare for installation:

- Download and install the latest software, firmware, and device drivers needed to configure the host device and the connected ACP devices (see the host device user guide, available at www.extron.com, for details regarding software and drivers).
- Obtain cables, mounting hardware, and any other supplies required for the installation.

ACP 105 EU/MK • Setup Guide (Continued)

Step 2: Prepare the Installation Site

ATTENTION:

- Installation and service must be performed by authorized personnel only.
- L'installation et l'entretien doivent être effectués par le personnel autorisé uniquement.
- Extron recommends installing the ACP 105 EU/MK into a grounded, UL Listed electrical junction box.
- Extron recommande d'installer le ACP 105 EU/MK dans un boîtier d'encastrement électrique mis à la terre, listé UL.
- If the ACP 105 EU/MK will be installed into fine furniture, it is best to hire a licensed, bonded craftsman to cut the access hole and perform the physical installation so the surface will not be damaged.
- S'il est prévu d'installer le ACP 105 EU/MK dans du beau mobilier, il est préférable de faire appel à un artisan autorisé et qualifié pour couper le trou d'accès et réaliser l'installation de telle façon que la surface ne soit pas endommagée.
- Follow all national and local building and electrical codes that apply to the installation site.
- Respectez tous les codes électriques et du bâtiment, nationaux et locaux, qui s'appliquent au site de l'installation.

NOTE: For the installation to meet UL requirements and comply with National Electrical Code (NEC), the ACP 105 EU/MK must be installed in a UL Listed junction box. The end user or installer must furnish the junction box. It is not included with the ACP 105 EU/MK.

Americans with Disabilities Act (ADA) Compliance

When planning where to install these devices, consider factors affecting accessibility of the button panel such as height from the floor, distance from obstructions, and how far a user must reach to press the buttons. For guidelines, see sections 307 ("Protruding Objects") and 308 ("Reach Ranges") of the 2010 *ADA Standards for Accessible Design* available at <http://www.ada.gov/regs2010/2010ADASTandards/2010ADASTandards.pdf>.

Site Preparation

Extron offers an assortment of mud rings, optional UL Listed in-wall junction boxes, external wall boxes (EWBs), and surface or tabletop mounting boxes for use with the ACP button panels. The ACP 105 EU and ACP 105 MK are 1-gang EU and MK size devices.

Step 3: Removing the Plastic Faceplate, Removing the Button Panel, and Changing the Buttons

The plastic faceplate and buttons can be replaced. Additional buttons ship with the device and others can be ordered from www.extron.com.

To change the buttons:

1. Insert the Extron removal tool (pry tool) between one side of the plastic faceplate and the button plate. Release the catch holding the wallplate to the metal mounting plate (see ① in the figure to the right). If necessary, use the pry tool to release the second catch on the opposite side.
2. Insert a small flat-bladed screw driver into a slot on the button plate to separate the button plate from the control plate (②).
3. Press the blade of the screw driver in until the tab is pushed out of the slot. There is an audible click.
4. Repeat steps 2 and 3 to release all four tabs holding the button plate in place.
5. Tilt the top of the button plate forward as it is removed to prevent the buttons from falling out (③).

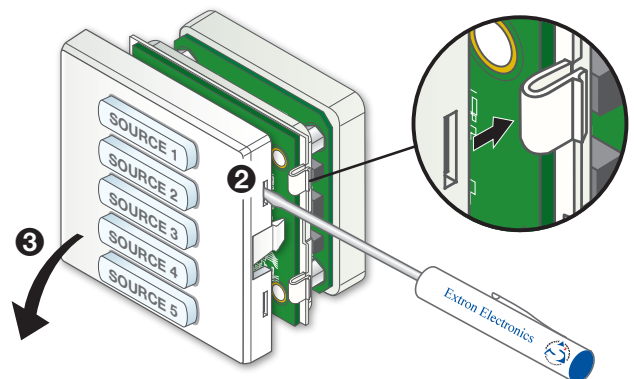
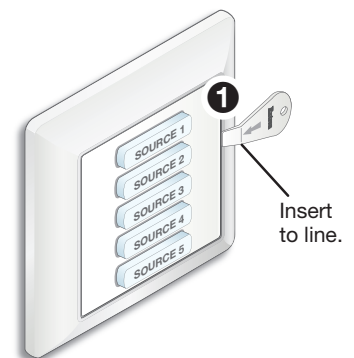

6. To remove a button, press a button backward through its slot in the button plate until the membrane containing the button is free.
7. To replace a button, align the two pegs in the button membrane with the holes located at opposite corners of the empty slot on the back of the button faceplate and push the button forward so it fits in the desired slot (see the figure to the right). Ensure the button text orientation is correct.
8. Repeat steps 5 and 6 to replace any other buttons.
9. Align the back of the button plate with the control plate and press it into place. The four tabs released in steps 2 through 4 snap back into place.
10. Ensure the plastic faceplate and metal mounting plate are in the correct orientation. To reattach the plastic faceplate, press the faceplate back into the metal mounting plate, using the two catches released in step 1 (on the previous page).

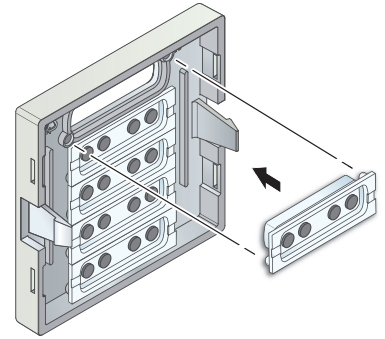

Step 4: Set Bus ID Address

Set the bus identification (bus ID) DIP switches for the ACP 105 EU/MK and any other ACP panels being connected to the system. Each ACP device must have a unique bus ID. If multiple panels have the same bus ID, address conflicts may cause one or more of the panels to not be recognized in DSP Configurator or by the host device. Up to eight ACP devices can be connected in the same system.

ACP Ports

- Connect up to eight (8) ACP endpoint devices per DMP 128 Plus.
- Wire the connectors the same at both ends.
- These ports are identical. You can connect devices interchangeably to either port.
- Do not exceed a total of 1000 feet (305 meters) of cable for connections between the DMP 128 Plus and all of the ACP panels.
- Power is provided by the DMP 128 Plus, a PS 1220EB power inserter, or an Extron 12 VDC power supply.

Bus ID Address DIP Switches

- Use these DIP switches to set the six-bit, binary bus address for the ACP 105 EU/MK.
- Each ACP connected to the same DMP 128 Plus must have a **unique** address.
- Switch 1 (on the left) is the highest value (32, the most significant bit [labeled "MSB"]).
- Switch 6 (on the right) is the lowest (1, the least significant bit [labeled "LSB"]).
- **Up** = on = 1, **Down** = off = 0

Examples:

Unit address	1	18
DIP switches		
Binary address	0 0 0 0 0 1	0 1 0 0 1 0

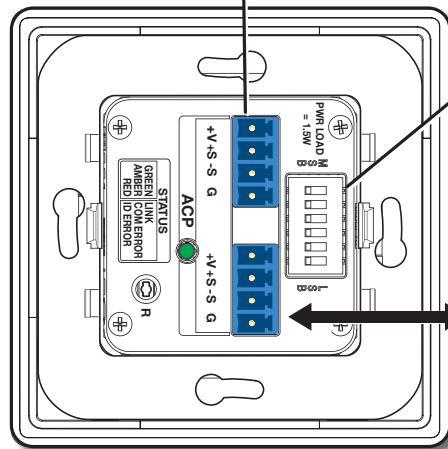







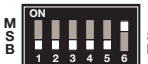

ACP port on a DMP 128 Plus, or on another ACP endpoint

ACP 105 EU/MK • Setup Guide (Continued)

Setting the Bus ID Address

Each ACP device in a system must have a unique six-digit binary bus ID. ACP bus IDs are set using the DIP switch assembly on the rear panel of the ACP 105 EU/MK (see **E** on figure 1 at the beginning of the guide).

Switch 1 on the left sets the most significant bit (highest number, 32) while switch 6 on the right sets the least significant bit (the lowest number, 1). See the example addresses to the right.

Example Addresses		
Bus ID (Decimal)	Binary Address	DIP Switch Setting
0	000000* *Reserved (for controller address)	
1	000001	
2	000010	
3	000011	
4	000100	
5	000101	
6	000110	
7	000111	
8	001000	

Step 5: Cable All Devices

1. Connect the ACP panel to the host device.
2. Connect ACP panels to each other if multiple panels are used in the system (see the wiring diagram below for correct wiring).

NOTES:

- Wire both ends of each ACP cable the same. Connectors are interchangeable between the host device and ACP devices.
- Do NOT power an ACP panel from more than one power source.

3. Apply power to the host device after correctly cabling all devices.

Cabling

Attach cables using the diagram below as a guide. Wiring is the same for all ACP models. Connect a 4-pole captive screw connector to each end of the cable, wiring both ends the same. In most cases, ACP devices are powered by the host device. Power is carried on the V+ pin of the ACP 105 EU/MK and other ACP devices.

Extron STP20-2/1000 or STP20-2P/100 cable is recommended for ACP device connections.

ACP devices that are relatively far from the host device can be connected to an optional Extron PS 1220EB eBUS power inserter or an Extron 12 VDC desktop power supply as shown in the diagrams below and on the next page (see the ACP 105 EU/MK Specifications at www.extron.com to determine if additional power is recommended).

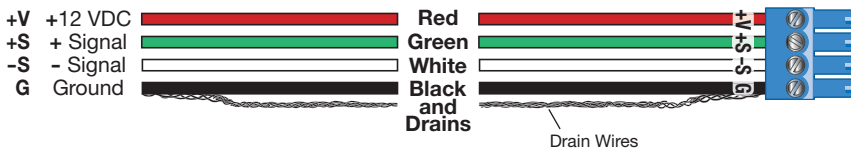

ATTENTION:

- Always use a power supply supplied or specified by Extron. Use of an unauthorized power supply voids all regulatory compliance certification and may cause damage to the supply and the unit.
- Utilisez toujours une source d'alimentation fournie par Extron. L'utilisation d'une source d'alimentation non autorisée annule toute conformité réglementaire et peut endommager la source d'alimentation ainsi que l'unité.
- If not provided with a power supply, this product is intended to be supplied by a UL Listed power source marked "Class 2" or "LPS" and rated output 12 VDC, minimum 1.0 A.
- Si ce produit ne dispose pas de sa propre source d'alimentation électrique, il doit être alimenté par une source d'alimentation certifiée UL de classe 2 ou LPS et paramétré à 12 VDC et 1,0 A minimum.
- Unless otherwise stated, the AC/DC adapters are not suitable for use in air handling spaces or in wall cavities.
- Sauf mention contraire, les adaptateurs AC/DC ne sont pas appropriés pour une utilisation dans les espaces d'aération ou dans les cavités murales.
- The installation must always be in accordance with the applicable provisions of National Electrical Code ANSI/NFPA 70, article 725 and the Canadian Electrical Code part 1, section 16. The power supply shall not be permanently fixed to building structure or similar structure.
- Cette installation doit toujours être en accord avec les mesures qui s'applique au National Electrical Code ANSI/NFPA 70, article 725, et au Canadian Electrical Code, partie 1, section 16. La source d'alimentation ne devra pas être fixée de façon permanente à une structure de bâtiment ou à une structure similaire.

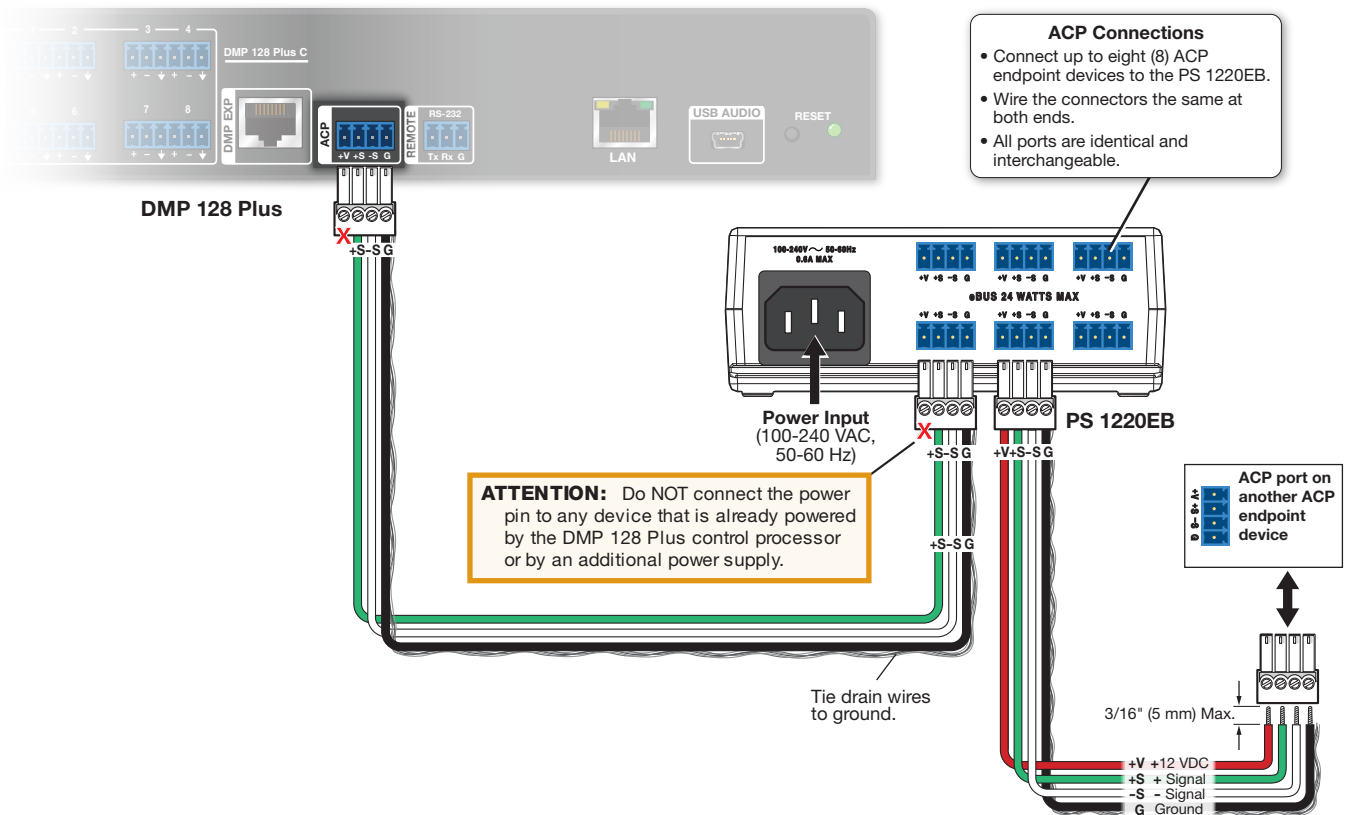

ACP 105 EU/MK • Setup Guide (Continued)

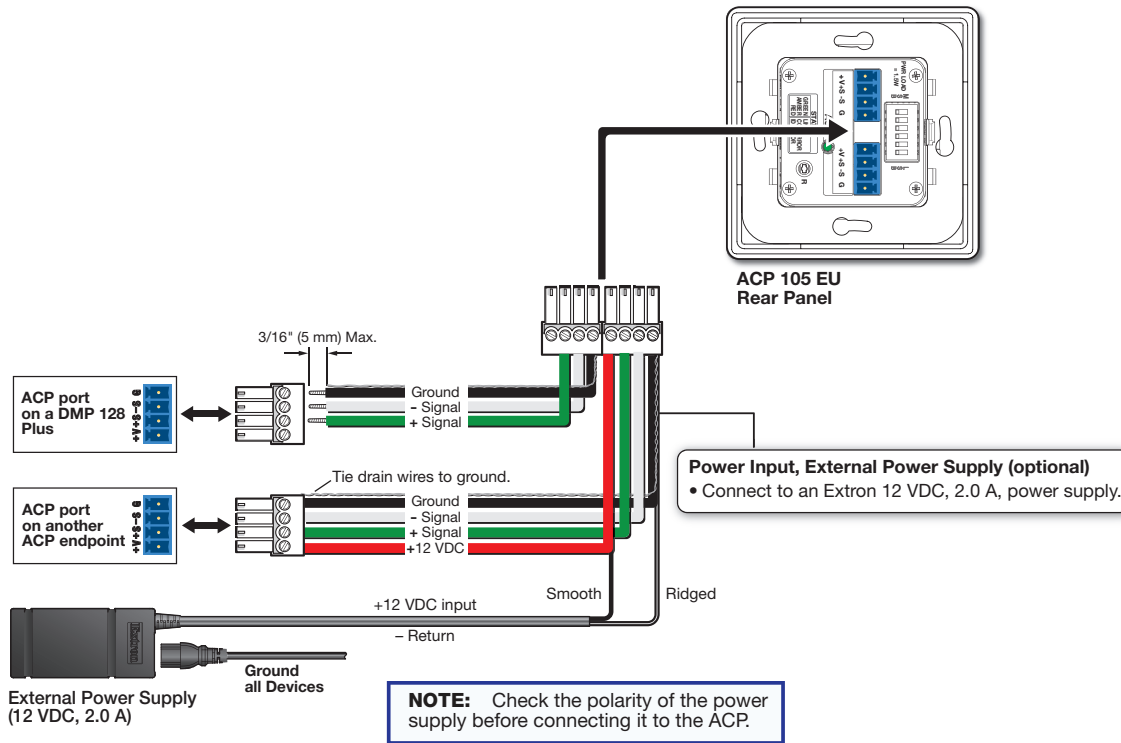

Step 6: Configure the System

NOTE: For complete information on creating configuration files and operating DSP Configurator Software, see the host device user guide or refer to the DSP Configurator Software product page at www.extron.com.

1. Create a new host device configuration file in DSP Configurator and create all groups, presets, and macros to be controlled by the ACP device.
2. Select **Tools>Configure ACPs** in DSP Configurator and configure the ACP button actions and panel IDs.
3. Connect to the host device in Live mode with a TCP/IP connection and push the configuration file to the device.

Step 7: Test and Troubleshoot

1. Verify the ACP bus ID DIP switches are set to the desired address on each unit and that there are no bus ID address conflicts in the system. As mentioned in the rear panel features diagram in step 4 (see page 3), the ACP LED lights green when power and communication are present and there are no bus ID address conflicts. Refer to the legend on the rear panel for other LED behavior indications.
2. Verify cables to and from the ACP devices are wired the same at each end.
3. Test the system:
 - a. Press the ACP device buttons and ensure the buttons light as expected and that the appropriate control actions are triggered. Commands can be verified using DSP Configurator. DataViewer can also be used for command verification if responses are configured.
 - b. Ensure the audio levels respond correctly to the volume and mute buttons.
4. Make adjustments to wiring, bus ID addresses, and system configuration as needed. Remember that the rear panel ports and DIP switches are not accessible after the ACP is mounted. If needed, push a revised configuration to the ACP device through the host device using DSP Configurator.

If you have questions during installation and setup, call the Extron S3 Sales and Technical Support Hotline or the Extron S3 Control Systems Support Hotline (1.800.633.9877).

Step 8: Mounting the ACP 105 EU/MK

Prior to mounting:

1. Feed all device cables through the wall or furniture.

NOTE: If the unit is not installed in a mud ring, the plastic spacer must be installed. The spacer positions the unit to allow the plastic faceplate to attach properly and securely.

2. Ensure the cables are connected to the ACP 105 EU/MK rear panel.

Mounting ACP 105 EU or ACP 105 MK Units to an Electrical Wall Box

NOTES:

- The electrical wall box is not provided and must be purchased separately.
- Install the electrical wall box by following the instructions provided by the manufacturer.
- Use the metal mounting bracket provided with the ACP unit. ACP 105 EU and ACP 105 MK metal mounting brackets are not interchangeable.

To mount an ACP 105 EU/MK:

1. Decide where the panel will be located. Take into consideration the position of wall studs and windows that could obstruct cable runs.
2. Install the electrical wall box by following the instructions provided by the manufacturer (see ❶ in the figure to the right).

NOTES:

- The metal mounting brackets provided with the EU and MK models are different and are not interchangeable.
- Ensure the bracket is in the correct orientation with the side marked "Front" facing away from the wall.
- The EU model is attached with screws at the top and bottom.
- The MK model is attached with screws on both sides.

3. Disconnect power from all devices at the source and run cables through the hole in the wall. Pass them through the metal mounting bracket and plastic faceplate to connect them to the rear panel captive screw connectors.
4. Set the DIP switches to give the panel a unique ID number.
5. Insert the ACP 105 EU/MK into the plastic faceplate (❸) and press the entire assembly into the metal mounting bracket (❷). The device is secured to the metal mounting bracket by two catches (on each side) that hold the wallplate in place.

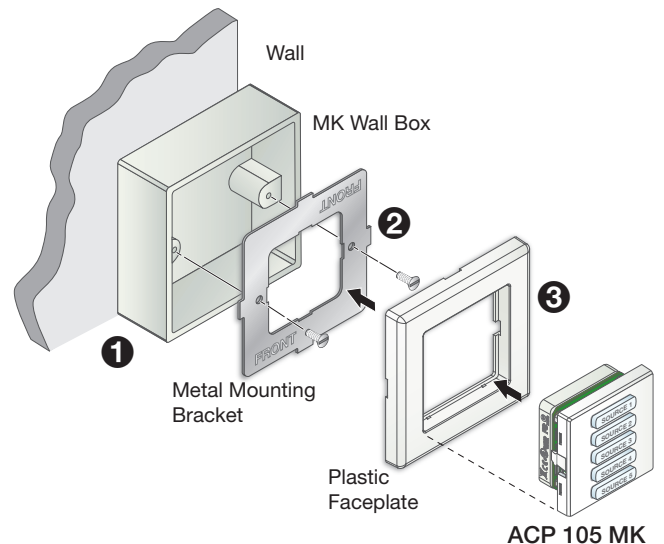
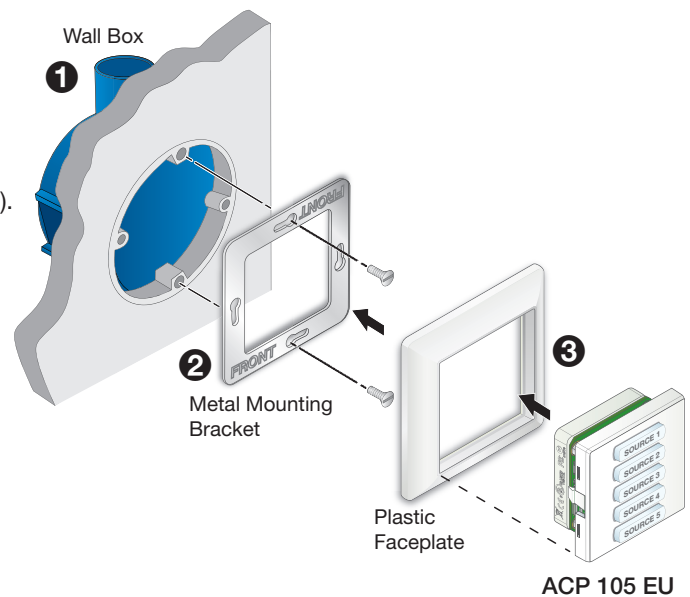

Mounting ACP 105 EU or ACP 105 MK Units in a Raceway

NOTES:

- If there is a gap between the metal mounting bracket and the wall frame, insert the provided spacer between the mounting bracket and the rim of the junction box (see figure below).
The spacer looks very similar to the metal mounting bracket, but has a slightly larger center opening, has holes instead of slots for the mounting screws, and is engraved with the words “Optional Spacer” and “Place behind bracket.”
- Do not use the spacer instead of the metal mounting bracket. The spacer has a larger opening and will not hold the ACP 105 EU/MK securely in the wall frame.

To mount the ACP 105 EU/MK to a raceway using the spacer:

1. Mount a junction box in the raceway (see ① in the figure to the right). Follow the instructions provided by the manufacturer.
 2. If required, align the screw holes of the provided spacer with the holes in the electrical box (②).
 3. Align the screw holes in the metal mounting bracket with the holes in the spacer and electrical box (③).
- NOTE:** Ensure that the front surface of the mounting bracket is facing out (away from the wall).
4. Use the two provided screws to secure the metal mounting bracket and spacer to the junction box (④). Leave the screw heads protruding approximately 1/8 inch (3.18 mm) from the surface of the spacer.
 5. Rotate the metal mounting bracket as necessary to ensure that the device will be aligned correctly on the mounting surface.
 6. Tighten the screws to secure the bracket to the spacer.
 7. Disconnect power from all devices at the source and run cables through the raceway, junction box, spacer, bracket and plastic faceplate. Connect them to the rear panel ACP ports on the device.
 8. Set the bus ID DIP switches to give the panel a unique address.
 9. Insert the device into the wallplate (see ⑤ in the figure above) and press the entire assembly into the metal mounting bracket (⑥).
The ACP 105 EU/MK is secured to the metal mounting bracket by two catches (one on each side) and holds the wallplate in place.

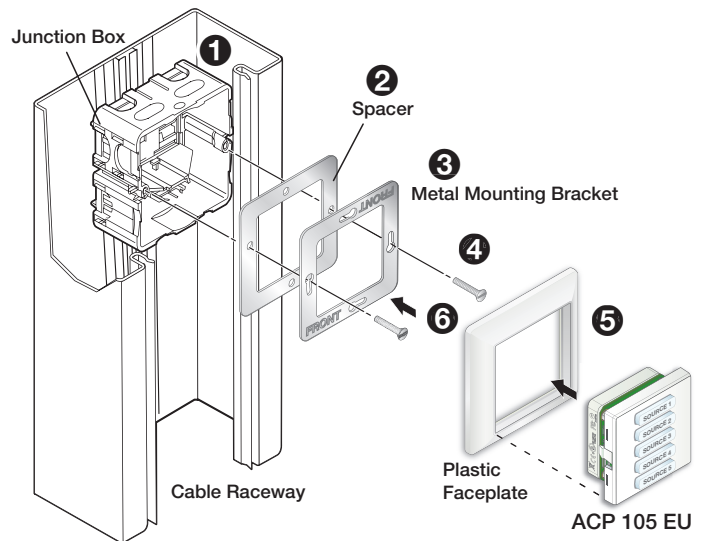

For information on safety guidelines, regulatory compliances, EMI/EMF compatibility, accessibility, and related topics, see the [Extron Safety and Regulatory Compliance Guide](#) on the Extron website.