



UCS FT 901 and UCS FR 902 • User Guide

IMPORTANT NOTE:

Go to www.extron.com for the complete UCS T 901 and UCS R 902 specifications before connecting the products to their power sources.



The UCS FT 901 and UCS FR 902 Fiber Optic USB Extenders extend USB signals from at least USB 3.2, 2.0, and 1.1 peripheral devices up to 492 ft (150 meters) to a USB host computer over multimode fiber optic cable with super speed data transfer rate of up to 5 Gbps.

The transmitter features a USB Type-C connector. The receiver features a built-in active two-port hub that supplies up to 5 V, 1.5 A for each port to power attached devices.

NOTES:

- This product supports USB data ONLY. DisplayPort Alt Mode and power delivery are NOT supported.
- The transmitter is compatible with USB Type C-to-C cable only.
- The use of USB 2.0 hub on the UCS FR 902 is not recommended. If a USB hub is needed, Extron recommends using a USB 3.2 hub. Please contact your Extron application Engineer (AE) for more details.

FCC Class A Notice

This equipment has been tested and found to comply with the limits for a Class A digital device, pursuant to part 15 of the FCC rules. The Class A limits provide reasonable protection against harmful interference when the equipment is operated in a commercial environment. This equipment generates, uses, and can radiate radio frequency energy and, if not installed and used in accordance with the instruction manual, may cause harmful interference to radio communications. Operation of this equipment in a residential area is likely to cause interference. This interference must be corrected at the expense of the user.

NOTE: For more information on safety guidelines, regulatory compliances, EMI/EMF compatibility, accessibility, and related topics, see the “[Extron Safety and Regulatory Compliance Guide](#)” on the Extron website.

Features

- **Point-to-point transmission** — Extends USB peripherals up to 492 ft (150 meters) over fiber optic cable for point-to-point applications.
- **Supports USB 3.2, 2.0, and 1.1 devices** — Supports bulk, control, interrupt, and isochronous transfers as defined by the USB specification.
- **Provides data transfer rates up to 5 Gbps** — Allows for the use of USB 3.2 cameras and other USB conference room peripherals requiring high bandwidth support.
- **Integrated dual-port devices** — The receiver has two integrated USB ports, which provide up to 5 volts, 1.5 amps on each port. This allows simultaneous connection to multiple peripheral devices such as USB cameras, docks, all-in-one conference systems, interactive displays, annotation devices, mass storage, keyboards, and mice in pro AV environments.
- **Real-time status LED indicators for troubleshooting and monitoring** — Front panel LED indicators provide visual confirmation of active host and link status.
- **Rack and furniture mountable** — Low-profile, 1-inch (2.5 cm) high, 3-inch deep (7.6 cm), eighth rack wide (UCS FT 901) and quarter rack wide (UCS FR 902) metal enclosures enable discreet installation, such as beneath a table or behind a display. One (1) ZipClip 100 and two (2) ZipClip 200 mounting accessories are included.
- **Transmitter can be powered via USB host** — UCS FT 901 can be powered by host PC or included external power supply.
- **External Extron Everlast power supply included** — Provides worldwide power compatibility with high-demonstrated reliability and low power consumption (Extron Everlast Power Supply is covered by a 7-year parts and labor warranty).

UCS FT 901 and UCS FR 902 • User Guide (Cont...)

ATTENTION:

- The power supply must not be permanently fixed to the building structure or similar structures.
- La source d'alimentation ne devra pas être fixée de façon permanente à une structure de bâtiment ou à une structure similaire.
- Do not mount the power supply in air handling spaces or in wall cavities.
- Ne pas installer la source d'alimentation dans des espaces d'aération ou dans des cavités murales.
- The installation must always be in accordance with the applicable provisions of National Electrical Code ANSI/NFPA 70, article 725 and the Canadian Electrical Code part 1, section 16.
- Cette installation doit toujours être conforme aux dispositions applicables du Code américain de l'électricité (National Electrical Code) ANSI/NFPA 70, article 725, et du Code canadien de l'électricité, partie 1, section 16.
- The power supply must be located within the same vicinity as the Extron AV processing equipment in an ordinary location, Pollution Degree 2, secured to a podium, a desk, or an equipment rack within a dedicated closet.
- La source d'alimentation doit être située à proximité de l'équipement audiovisuel Extron dans un emplacement habituel, avec un degré de pollution 2, fixée à une estrade, un bureau, ou dans une baie technique à l'intérieur d'un placard dédié.
- Always use a power supply provided by or specified by Extron. Use of an unauthorized power supply voids all regulatory compliance certification and may cause damage to the supply and the end product.
- Utilisez toujours une source d'alimentation fournie ou recommandée par Extron. L'utilisation d'une source d'alimentation non autorisée annule toute certification de conformité réglementaire, et peut endommager la source d'alimentation et l'unité.
- If not provided with a power supply, this product is intended to be supplied by a power source marked "Class 2" or "LPS" and rated at 12 VDC, minimum 1.6 A.
- Si ce produit ne dispose pas de sa propre source d'alimentation électrique, il doit être alimenté par une source d'alimentation de classe 2 ou LPS et paramétré à 12 V et 1,6 A minimum.

- B Host (Input) connector** — Connects a USB Type C-to-C cable between this USB-C port and a USB 3.2 port of a host device. The UCS FT 901 can be powered by a connected host via the USB power circuit or by external power supply.

NOTE: The transmitter is compatible with USB Type C-to-C cable only, and connected to a USB 3.2 host port ONLY. Ensure that the USB cable used between the Host PC and transmitter host port supports at least USB 3.2 for proper operation. USB 3.2 ports are Type C and labeled with a SuperSpeed trident logo (see images below).



C Fiber I/O connectors —

- **Transmitter** — Connects multimode fiber optic cables from the receiver Input connectors to the transmitter Output connectors.
- **Receiver** — Connects multimode fiber optic cables from the transmitter Output connectors to the receiver Input connectors.

- D USB Devices connectors** — The two built-in female USB Type A connectors are USB 3.2, 2.0, and 1.1 compatible, providing +5 VDC at up to 1.5 A to connected USB peripherals requiring power.

Cabling and Setup

Figure 4 shows connections for the UCS FT 901 and UCS FR 902.

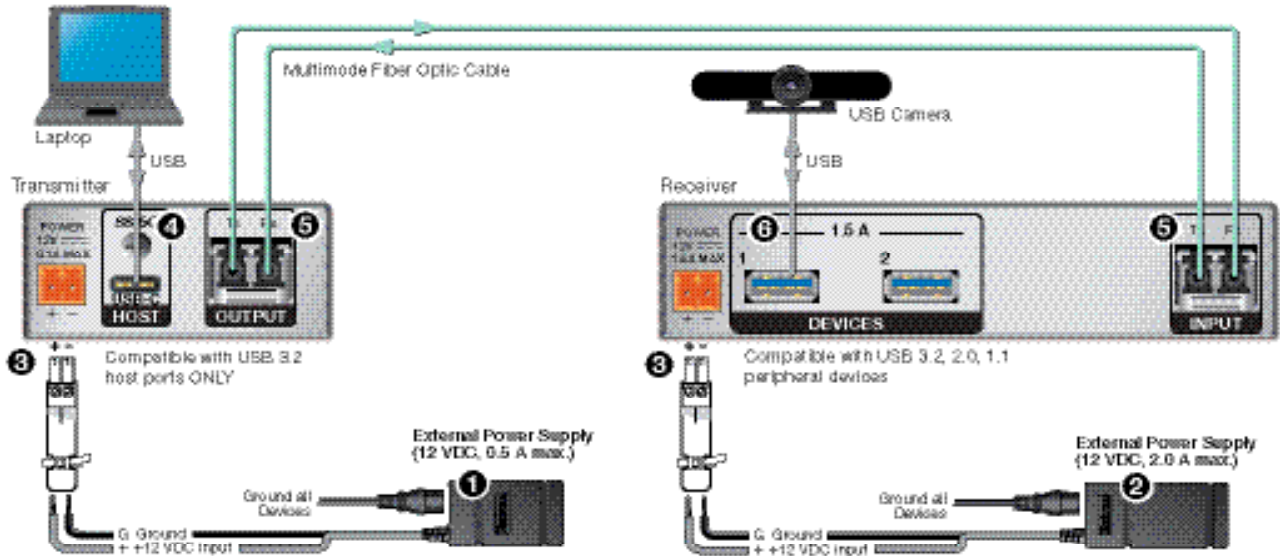

Figure 4. Transmitter and Receiver Connection with Two External Power Supplies

Installation Procedure

ATTENTION:

- Installation and service must be performed by authorized personnel only.
- L'installation et l'entretien doivent être effectués uniquement par un technicien qualifié.

To ensure proper operation, the transmitter, receiver, USB host, and USB peripherals must be connected properly and in the sequence described here (see figure 4, above).

1. Power off all devices that will be directly connected to the receiver.
2. Wire each of the two provided power supplies to their 2-pole captive screw connectors (see figure 5, below).

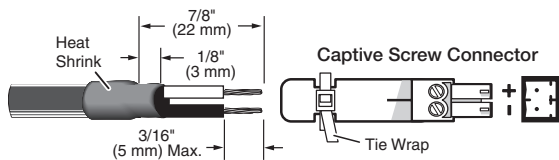

Figure 5. Wiring the Power Connector for the UCS FT 901 and FR 902

NOTE: The UCS FT 901 transmitter can also be powered by the host device, without the need for the external power supply.

3. Plug the two power supply connectors into their respective transmitter or receiver rear panel connectors (see figure 4, 3). Connect the 6 watt power supply (1) to the transmitter, and the 24 watt (2) to the receiver. The green Power LED (see figure 6, A, on page 5) on the front panel of each device lights when each device is powered on.
4. Connect a USB Type C-to-C cable from the host device to the transmitter HOST input (see figure 4, 4). The Host LED (see figure 6, B) lights, indicating that communication between the transmitter and host device has been established.

NOTE: Ensure that the USB cable between the host device and the transmitter (see figure 4, 4) supports USB 3.2 for proper operation.

UCS FT 901 and UCS FR 902 • User Guide (Cont...)

5. Connect a multimode fiber optic cable from the Output port of the transmitter to the Input port of the receiver (figure 4, 5). The transmitter and receiver front panel LINK LEDs will light steadily (figures 6 and 7, C).
6. If appropriate, choose a location and mount the transmitter and receiver
 - For rack mounting, fasten the enclosure to the rack or rack shelf.
 - For furniture mounting, see [ZipClip 100 and 200 Installation and Mounting](#) on the next page.
 - For table mounting, attach the provided four rubber feet to the bottom of the unit and place it where desired.
7. Power on the host computer. On the transmitter, the HOST and LINK LEDs (B and C) light when the computer recognizes the transmitter, and when the transmitter and receiver are connected with each other.
8. Connect up to two USB peripheral devices (such as a camera, keyboard, touchpanel or printer) to the receiver USB ports (figure 4, 6).

The system is now ready to operate.

Front Panel Features

UCS FT 901

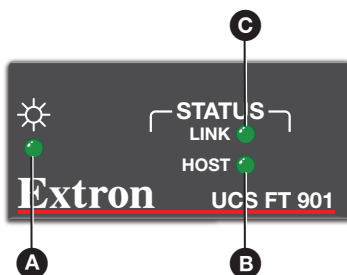

Figure 6. Transmitter Front Panel

UCS FR 902

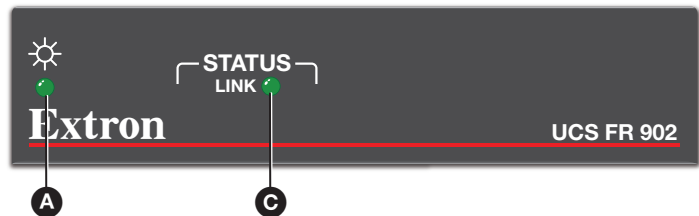

Figure 7. Receiver Front Panel

- A Power LED** — This green LED lights to indicate that the transmitter or receiver unit is receiving power.
- B Host LED** — This green LED lights when the transmitter is powered by and communicating with the active host PC.
- C Link LED** — This green LED lights when the transmitter and receiver are connected by a fiber optic cable, receiving power and communicating with the host PC.

NOTE: If the transmitter is powered by a host PC, but is not connected to the receiver, only the HOST LED (B) lights. If the transmitter and receiver are powered locally and connected via fiber cable, but no PC is connected, the LINK LED (C) does not light on either unit.

UL Guidelines for Rack Mounting

The following Underwriters Laboratories (UL) guidelines pertain to the installation of the UCS FT 901 and UCS FR 902:

CAUTION: Risk of minor personal injury:

- **Elevated operating ambient temperature** — If the equipment is installed in a closed or multi-unit rack assembly, the operating ambient temperature of the rack environment may be greater than room ambient. Therefore, consider installing the equipment in an environment compatible with the maximum ambient temperature (T_{ma}) specified by Extron.
- **Reduced air flow** — Install the equipment in the rack so that the amount of air flow required for safe operation of the equipment is not compromised.
- **Mechanical loading** — Mount the equipment in the rack so that uneven mechanical loading does not create a hazardous condition.
- **Circuit overloading** — When connecting the equipment to the supply circuit, consider the connection of the equipment to the supply circuit and the effect that circuit overloading might have on overcurrent protection and supply wiring. Consider equipment nameplate ratings when addressing this concern.
- **Reliable earthing (grounding)** — Maintain reliable grounding of rack-mounted equipment. Pay particular attention to supply connections other than direct connections to the branch circuit (such as the use of power strips).

Consignes UL pour le Montage en Rack

Les consignes UL (« Underwriters Laboratories ») suivantes concernent l'installation de UCS FT 901 et UCS FR 902:

ATTENTION : Risque de blessure mineure :

- **Température ambiante élevée** — En cas d'installation de l'équipement dans un rack fermé ou composé de plusieurs unités, la température du rack peut être supérieure à la température ambiante. Par conséquent, il est préférable d'installer l'équipement dans un environnement qui respecte la température ambiante maximale (T_{ma}) spécifiée par Extron.
- **Réduction du flux d'air** — Si l'équipement est installé dans un rack, veillez à ce que le flux d'air nécessaire pour un fonctionnement sécurisé de l'équipement soit respecté.
- **Charge mécanique** — Installez l'équipement en rack de manière à éviter toute situation dangereuse causée par le déséquilibre de la charge mécanique.
- **Surcharge électrique** — Lorsque vous connectez l'équipement au circuit d'alimentation, observez la connexion de l'équipement et étudiez les effets possibles d'une surcharge du circuit sur les protections contre les surintensités et les conducteurs d'alimentation. Consultez à cet égard les indications de la plaque d'identification de l'équipement.
- **Mise à la terre** — Assurez-vous que l'équipement est correctement mis à la terre. Accordez une attention particulière aux connexions électriques autres que les connexions directes au circuit de dérivation (ex. : les multiprises).

ZipClip 100 and 200 Installation and Mounting

Both the UCS FT 901 and UCS FR 902, alongside their respective external power supplies (PS 1205 C and PS 1220), can be mounted under a desk, onto a wall or other furniture using the ZipClip 200 and 100 (included). See ZipClip mounting options at www.extron.com.

1. Mount the ZipClip 200 onto a rack rail or an under-desk mounting surface or using the four included mounting screws (see figure 8). For the receiver power supply (PS 1220), mount the ZipClip 100, adjacent to the ZipClip 200. Mount the UCS transmitter or receiver to the ZipCaddy 200.

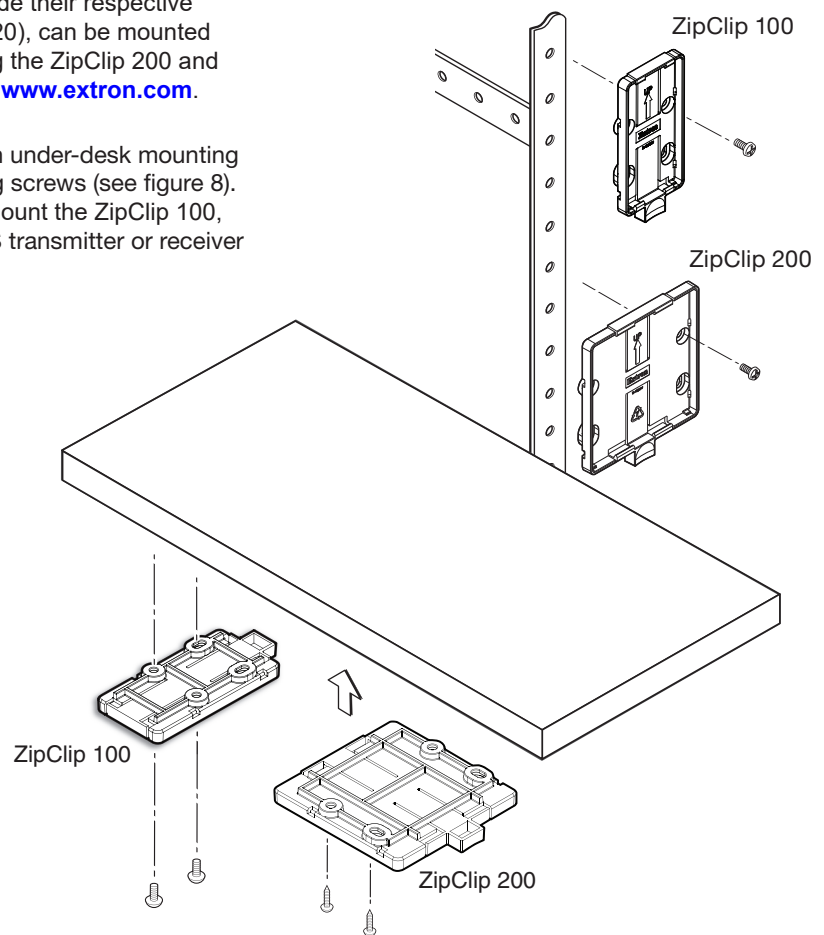

Figure 8. Rack Rail and Under-desk Mounting (ZipClip 100 and 200)

UCS FT 901 and UCS FR 902 • User Guide (Cont...)

2. If mounting the transmitter, also mount its external power supply (PS 1205 C) as follows:

Align the mounting holes on the bottom of the UCS unit with the mounting holes on the ZipCaddy 200 (see figure 9), and fasten the screws.

NOTE: The receiver power supply (PS 1220) attaches directly to the ZipClip 100 (see figure 10).

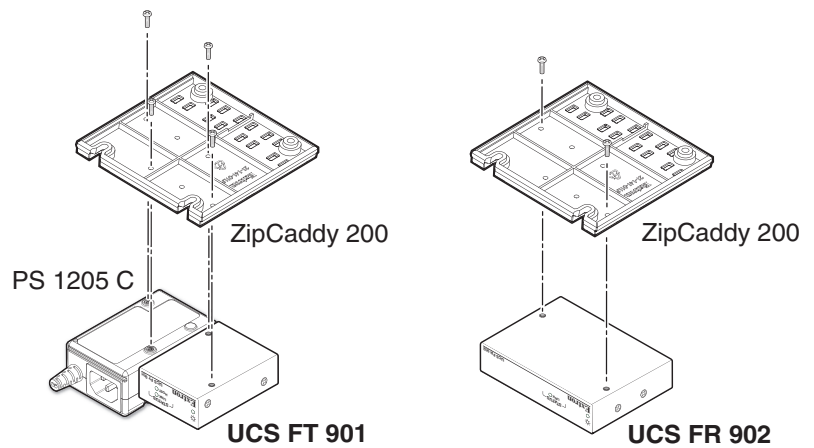

Figure 9. ZipCaddy Mounting (UCS FT 901 and UCS FR 902)

3. The transmitter (with power supply) or receiver can now be easily attached and detached from the ZipClip 200 mounting location, using the quick-release tab.

The receiver power supply (PS 1220) can be attached and detached from the ZipClip 100 (no ZipCaddy necessary).

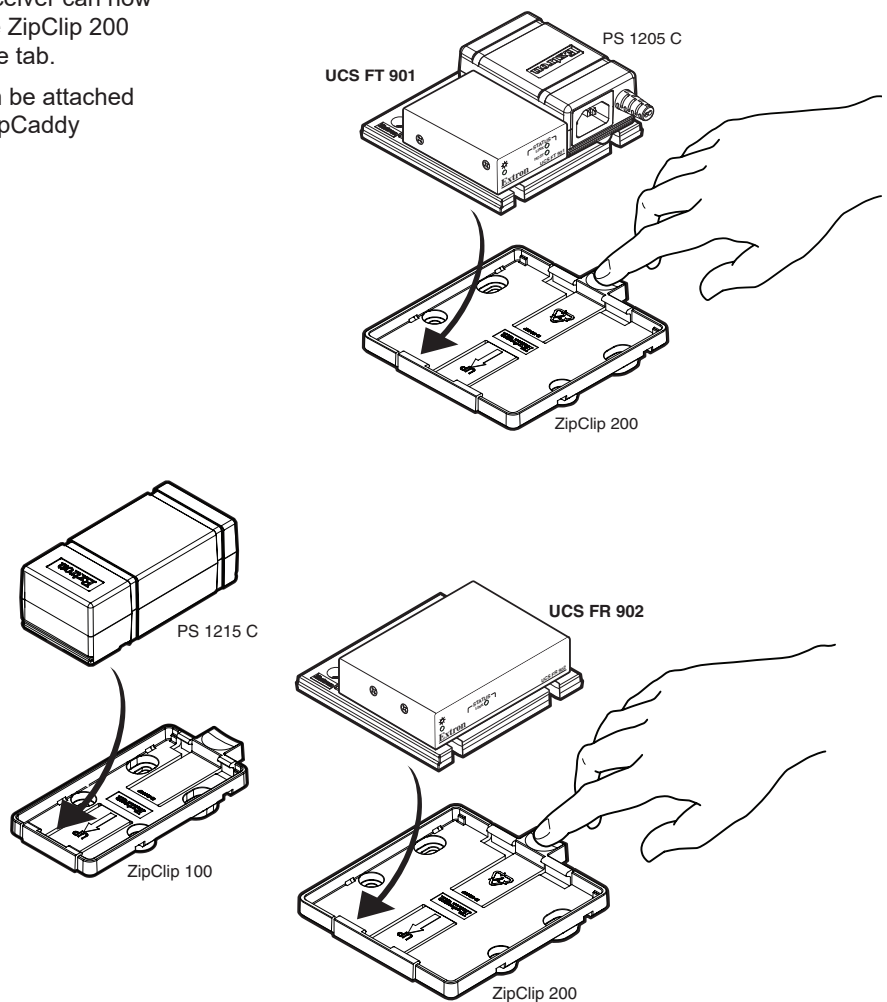

Figure 10. Attaching the UCS FT 901, UCS FR 902, and PS 1220

System Operation

No drivers are required for a host PC to function with the UCS FT 901 and UCS FR 902. The transmitter is detected by the operating system, and appropriate USB drivers are loaded. Certain USB peripherals, such as gaming keyboards, USB interactive white boards, scanners, printers, and similar devices, require specific drivers installed on the PC. To obtain drivers, see the USB device installation instructions or the peripheral device manufacturer website.

The system is fully operational when the transmitter, receiver, PC or USB host, and peripherals are connected and powered. If problems are encountered, ensure that all cables are routed and connected properly, and that the latest drivers for each peripheral are installed.

Troubleshooting

USB signals are generally reliable, but are susceptible to bad connections or signal loss from cables that are too long. The fiber optic cables can have the same issues. To avoid loss of data and communication, follow these guidelines:

- The USB cables that connect the transmitter to the host, or the receiver to peripheral devices, should not exceed 6 feet (1.8 meters).
- When connecting the host or peripherals, use only cables designed for USB signals.
- Avoid or limit the use of adapters.
- The UCS FT 901 and UCS FR 902 work as described in point-to-point applications. Do not use additional adapters, patch panels, or couplers with USB cables or fiber optic cables. Additional links in the signal chain can result in reduction of signal integrity and overall system performance.

When properly connected and operating, the transmitter and receiver Power LEDs, Link LEDs and Host LEDs are lit. Front panel LEDs are also useful for troubleshooting. The following table outlines the status indicated by each LED:

	Transmitter		Receiver	
LED Indicator	On	Off	On	Off
Power	Transmitter is connected to a host PC or 12 VDC power supply, and is operating properly.	Transmitter is NOT connected to a host PC or 12 VDC power supply, or is defective.	12 VDC power supply is connected and operating properly.	12 VDC power supply is not connected, or is defective.
Link	Both transmitter and receiver have power, and are connected properly by a multimode fiber optic cable.	If both Power LEDs are on, the multimode fiber optic cable is not connected or is improperly wired. If either Power LED is off, see the Power LED troubleshooting instructions above. If the Link LED does not light on either unit, but both the transmitter and receiver are locally powered and are connected via fiber cable, then the PC is not connected to the transmitter.	Both transmitter and receiver have power, and are connected properly by a multimode fiber optic cable.	If both Power LEDs are on, the multimode fiber optic cable is not connected or is improperly wired. If either Power LED is off, see the Power LED troubleshooting instructions above. If the Link LED does not light on either unit, but both the transmitter and receiver are locally powered and are connected via fiber cable, then the PC is not connected to the transmitter.
Host	When transmitter power LED is on, this Host LED lights when communication with host PC is established.	If transmitter power LED is on, USB cable is not connected.	N/A	N/A

For information on safety guidelines, regulatory compliances, EMI/EMF compatibility, accessibility, and related topics, see the [Extron Safety and Regulatory Compliance Guide](#) on the Extron website.