

UCS SW 313

Three Input 4K/60 Collaboration
and Presentation Switcher

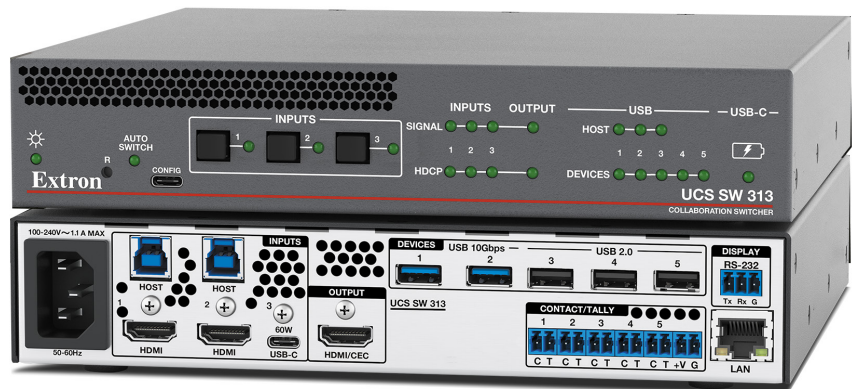

User Guide Collaboration Switchers

Safety Instructions

Safety Instructions • English

WARNING: This symbol, , when used on the product, is intended to alert the user of the presence of uninsulated dangerous voltage within the product's enclosure that may present a risk of electric shock.

ATTENTION: This symbol, , when used on the product, is intended to alert the user of important operating and maintenance (servicing) instructions in the literature provided with the equipment.

For information on safety guidelines, regulatory compliances, EMI/EMF compatibility, accessibility, and related topics, see the Extron Safety and Regulatory Compliance Guide, part number 68-290-01, on the Extron website, www.extron.com.

تعليمات السلامة • العربية

تحذير: هذا الرمز، , عند استخدامه على المنتج، مخصص لتنبيه المستخدم فيما يتعلق بوجود جهد كهربائي غير معزول على الغلاف الخارجي للمنتج وهو ما قد ينطوي على مخاطر حدوث صدمة كهربائية.

انتبه: هذا الرمز، , عند استخدامه على المنتج، مخصص لتنبيه المستخدم بتعليمات التشغيل والصيانة الهامة (الخدمة) في المواد التي يتم توفيرها مع المعدات.

للحصول على المزيد من المعلومات حول إرشادات السلامة، والتوافق التنظيمية، والتوافق الكهرومغناطيسي/المجال الكهرومغناطيسي، وإمكانية الوصول، والموضوعات ذات الصلة، يرجى مراجعة دليل السلامة والتوافق التنظيمي www.extron.com الخاص بإكسترون، الجزء رقم 68-290-01، على موقع إكسترون.

Sicherheitsanweisungen • Deutsch

WARUNG: Dieses Symbol , auf dem Produkt soll den Benutzer darauf aufmerksam machen, dass im Inneren des Gehäuses dieses Produktes gefährliche Spannungen herrschen, die nicht isoliert sind und die einen elektrischen Schlag verursachen können.

VORSICHT: Dieses Symbol , auf dem Produkt soll dem Benutzer in der im Lieferumfang enthaltenen Dokumentation besonders wichtige Hinweise zur Bedienung und Wartung (Instandhaltung) geben.

Weitere Informationen über die Sicherheitsrichtlinien, Produkthandhabung, EMI/EMF-Kompatibilität, Zugänglichkeit und verwandte Themen finden Sie in den Extron-Richtlinien für Sicherheit und Handhabung (Artikelnummer 68-290-01) auf der Extron-Website, www.extron.com.

Instrucciones de seguridad • Español

ADVERTENCIA: Este símbolo, , cuando se utiliza en el producto, avisa al usuario de la presencia de voltaje peligroso sin aislar dentro del producto, lo que puede representar un riesgo de descarga eléctrica.

ATENCIÓN: Este símbolo, , cuando se utiliza en el producto, avisa al usuario de la presencia de importantes instrucciones de uso y mantenimiento estas están incluidas en la documentación proporcionada con el equipo.

Para obtener información sobre directrices de seguridad, cumplimiento de normativas, compatibilidad electromagnética, accesibilidad y temas relacionados, consulte la Guía de cumplimiento de normativas y seguridad de Extron, referencia 68-290-01, en el sitio Web de Extron, www.extron.com.

Instructions de sécurité • Français

AVERTISSEMENT : Ce pictogramme, , lorsqu'il est utilisé sur le produit, signale à l'utilisateur la présence à l'intérieur du boîtier du produit d'une tension électrique dangereuse susceptible de provoquer un choc électrique.

ATTENTION : Ce pictogramme, , lorsqu'il est utilisé sur le produit, signale à l'utilisateur des instructions d'utilisation ou de maintenance importantes qui se trouvent dans la documentation fournie avec l'équipement.

Pour en savoir plus sur les règles de sécurité, la conformité à la réglementation, la compatibilité EMI/EMF, l'accessibilité, et autres sujets connexes, lisez les informations de sécurité et de conformité Extron, réf. 68-290-01, sur le site Extron, www.extron.com.

Istruzioni di sicurezza • Italiano

AVVERTENZA: Il simbolo, , se usato sul prodotto, serve ad avvertire l'utente della presenza di tensione non isolata pericolosa all'interno del contenitore del prodotto che può costituire un rischio di scosse elettriche.

ATTENZIONE: Il simbolo, , se usato sul prodotto, serve ad avvertire l'utente della presenza di importanti istruzioni di funzionamento e manutenzione nella documentazione fornita con l'apparecchio.

Per informazioni su parametri di sicurezza, conformità alle normative, compatibilità EMI/EMF, accessibilità e argomenti simili, fare riferimento alla Guida alla conformità normativa e di sicurezza di Extron, cod. articolo 68-290-01, sul sito web di Extron, www.extron.com.

Instrukcje bezpieczeństwa • Polska

OSTRZEŻENIE: Ten symbol, , gdy używany na produkt, ma na celu poinformować użytkownika o obecności izolowanego i niebezpiecznego napięcia wewnątrz obudowy produktu, który może stanowić zagrożenie porażenia prądem elektrycznym.

UWAGI: Ten symbol, , gdy używany na produkt, jest przeznaczony do ostrzegania użytkownika ważne operacyjne oraz instrukcje konserwacji (obsługi) w literaturze, wyposażone w sprzęt.

Informacji na temat wytycznych w sprawie bezpieczeństwa, regulacji wzajemnej zgodności, zgodność EMI/EMF, dostępności i Tematy pokrewne, zobacz Extron bezpieczeństwa i regulacyjnego zgodności przewodnik, część numer 68-290-01, na stronie internetowej Extron, www.extron.com.

Инструкция по технике безопасности • Русский

ПРЕДУПРЕЖДЕНИЕ: Данный символ, , если указан на продукте, предупреждает пользователя о наличии неизолированного опасного напряжения внутри корпуса продукта, которое может привести к поражению электрическим током.

ВНИМАНИЕ: Данный символ, , если указан на продукте, предупреждает пользователя о наличии важных инструкций по эксплуатации и обслуживанию в руководстве, прилагаемом к данному оборудованию.

Для получения информации о правилах техники безопасности, соблюдении нормативных требований, электромагнитной совместимости (ЭМП/ЭДС), возможности доступа и других вопросах см. руководство по безопасности и соблюдению нормативных требований Extron на сайте Extron: www.extron.com, номер по каталогу - 68-290-01.

安全说明 • 简体中文

警告: 产品上的这个标志意在警告用户，该产品机壳内有暴露的危险电压，有触电危险。

注意: 产品上的这个标志意在提示用户，设备随附的用户手册中有重要的操作和维护(维修)说明。

关于我们产品的安全指南、遵循的规范、EMI/EMF 的兼容性、无障碍使用的特性等相关内容，请访问 Extron 网站，www.extron.com，参见 Extron 安全规范指南，产品编号 68-290-01。

安全記事 • 繁體中文

警告: 若產品上使用此符號, 是為了提醒使用者, 產品機殼內存在未隔離的危險電壓, 可能會導致觸電之風險。

注意: 若產品上使用此符號, 是為了提醒使用者, 設備隨附的用戶手冊中有重要的操作和維護(維修)說明。

有關安全性指導方針、法規遵守、EMI/EMF 相容性、存取範圍和相關主題的詳細資訊, 請瀏覽 Extron 網站: www.extron.com, 然後參閱《Extron 安全性與法規遵守手冊》, 準則編號 68-290-01。

安全上のご注意 • 日本語

警告: この記号 が製品上に表示されている場合は、筐体内に絶縁されていない高電圧が流れ、感電の危険があることを示しています。

注意: この記号 が製品上に表示されている場合は、本機の取扱説明書に記載されている重要な操作と保守(整備)の指示についてユーザーの注意を喚起するものです。

安全上のご注意、法規遵守、EMI/EMF適合性、その他の関連項目については、エクストロンのウェブサイト www.extron.com より『Extron Safety and Regulatory Compliance Guide』(P/N 68-290-01) をご覧ください。

안전 지침 • 한국어

경고: 이 기호 가 제품에 사용될 경우, 제품의 인클로저 내에 있는 접지되지 않은 위험한 전류로 인해 사용자가 감전될 위험이 있음을 경고합니다.

주의: 이 기호 가 제품에 사용될 경우, 장비와 함께 제공된 책자에 나와 있는 주요 운영 및 유지보수(정비) 지침을 경고합니다.

안전 가이드라인, 규제 준수, EMI/EMF 호환성, 접근성, 그리고 관련 항목에 대한 자세한 내용은 Extron 웹 사이트(www.extron.com)의 Extron 안전 및 규제 준수 안내서, 68-290-01 조항을 참조하십시오.

Copyright

© 2025-2026 Extron. All rights reserved. www.extron.com

Trademarks

All trademarks mentioned in this guide are the properties of their respective owners.

The following registered trademarks (®), registered service marks (SM), and trademarks (TM) are the property of RGB Systems, Inc. or Extron (see the current list of trademarks on the [Terms of Use](http://www.extron.com) page at www.extron.com):

Registered Trademarks (®)
Extron®, Cable Cubby®, ControlScript®, CrossPoint®, DTP®, eBUS®, EDID Manager®, EDID Minder®, eLink®, Everlast®, Flat Field®, FlexOS®, Glitch Free®, GlobalViewer®, Global Configurator®, Global Scriptor®, Hideaway®, HyperLane®, IP Intercom®, IP Link®, Key Minder®, LinkLicense®, LockIt Plus®, MediaLink®, MediaPort®, NAV®, NetPA®, PlenumVault®, PoleVault®, PowerCage®, PURE3®, Quantum®, ShareLink®, Show Me®, StudioStation®, SoundField®, SpeedMount®, SpeedSwitch®, System INTEGRATOR®, TeamWork®, TouchLink®, V-Lock®, VN-Matrix®, VoiceLift®, WallVault®, WindoWall®, XPA®, XTP®, XTP Systems®, and ZipClip®
Registered Service Mark (SM) : S3 Service Support Solutions
Trademarks (TM)
AAP™, AFL™ - Accu-RATE Frame Lock, ADSP™ - Advanced Digital Sync Processing, AVEdge™, CableCover™, CDRS™ - Class D Ripple Suppression, Codec Connect™, DDSP™ - Digital Display Sync Processing, DMI™ - Dynamic Motion Interpolation, Driver Configurator™, DSP Configurator™, DSP Configurator PRO™, DSVP™ - Digital Sync Validation Processing, EQIP™, FastBite™, Flex55™, FOX™, FOXBOX™, InstaWake™, IP Intercom HelpDesk™, MAAP™, MicroDigital™, Opti-Torque™, PendantConnect™, ProDSP™, QS-FPC™ - QuickSwitch Front Panel Controller, Room Agent™, Scope-Trigger™, SIS™ - Simple Instruction Set, Skew-Free™, SpeedNav™, Triple-Action Switching™, True4K™, True8K™, Vector™ 4K, WebShare™, XTRA™, and ZipCaddy™

FCC Class A Notice

This equipment has been tested and found to comply with the limits for a Class A digital device, pursuant to part 15 of the FCC rules. The Class A limits provide reasonable protection against harmful interference when the equipment is operated in a commercial environment. This equipment generates, uses, and can radiate radio frequency energy and, if not installed and used in accordance with the instruction manual, may cause harmful interference to radio communications. Operation of this equipment in a residential area is likely to cause interference. This interference must be corrected at the expense of the user.

NOTES:

- This unit was tested with shielded I/O cables on the peripheral devices. Shielded cables must be used to ensure compliance with FCC emissions limits.
- For more information on safety guidelines, regulatory compliances, EMI/EMF compatibility, accessibility, and related topics see the [Extron Safety and Regulatory Compliance Guide](#) on the Extron website.

VCCI-A Notice

この装置は、クラスA情報技術装置です。この装置を家庭環境で使用すると、電波妨害を引き起こすことがあります。その場合には使用者が適切な対策を講ずるよう要求されることがあります。

VCCI-A

Battery Notice

This product contains a battery. **Do not open the unit to replace the battery.** If the battery needs replacing, return the entire unit to Extron (for the correct address, see the [Extron Warranty](#) section on the last page of this guide).

CAUTION: Risk of explosion. Do not replace the battery with an incorrect type. Dispose of used batteries according to the instructions.

ATTENTION : Risque d'explosion. Ne pas remplacer la pile par le mauvais type de pile. Débarrassez-vous des piles usagées selon le mode d'emploi.

Conventions Used in this Guide

Notifications

The following notifications are used in this guide:

CAUTION: Risk of minor personal injury.

ATTENTION : Risque de blessure mineure.

ATTENTION:

- Risk of property damage.
- Risque de dommages matériels.

NOTE: A note draws attention to important information.

Software Commands

Commands are written in the fonts shown here:

```
^AR Merge Scene,,0p1 scene 1,1 ^B 51 ^W^C.0  
[01] R 0004 00300 00400 00800 00600 [02] 35 [17] [03]  
[Esc] [X1] * [X17] * [X20] * [X23] * [X21] CE ←
```

NOTE: For commands and examples of computer or device responses used in this guide, the character “ø” is used for the number zero and “O” is the capital letter “o.”

Computer responses and directory paths that do not have variables are written in the font shown here:

```
Reply from 208.132.180.48: bytes=32 times=2ms TTL=32  
C:\Program Files\Extron
```

Variables are written in slanted form as shown here:

```
ping xxx.xxx.xxx.xxx -t  
SOH R Data STX Command ETB ETX
```

Selectable items, such as menu names, menu options, buttons, tabs, and field names are written in the font shown here:

```
From the File menu, select New.  
Click the OK button.
```

Specifications Availability

Product specifications are available on the Extron website, www.extron.com.

Extron Glossary of Terms

A glossary of terms is available at <https://www.extron.com/technology/glossary.aspx>.

Contents

Introduction.....	1
About this Guide	1
About the UCS SW 313 Switcher	1
Features	1
USB System Architecture	3
Application Diagrams.....	4
Installation.....	5
Installation Overview	5
Rear Panel Connections.....	6
Wiring the CONTACT/TALLY Connectors.....	8
Connecting Using a Show Me Cable	10
LockIt Plus HDMI Cable Lacing Bracket Installation	10
Wiring the LAN Port.....	11
Connecting Multiple UCS SW 313 Switchers in a System	12
Operation.....	13
Front Panel Features.....	13
Powering on the Switcher	14
Selecting an Input.....	14
Auto-switching	15
Auto-switch Modes.....	15
Auto-switch Type	15
Resetting	16
Front Panel Lock Mode (Executive Mode)	17
HDCP.....	17
Inputs	17
Output	17
HDCP Authorized Setting.....	17
HDCP Encryption	18
HDCP Notification	18
Color Bit Depth	18
USB-C Input	18
DisplayPort Alt Mode	18
USB-C Power Delivery.....	19
RS-232 Signal Insertion.....	19
Ethernet to RS-232 Insertion.....	20
Captive Screw Signal Insertion	21

SIS Communication and Control	22
Using the Simple Instruction Set Commands	22
Host-to-switcher Communications	22
Switcher-initiated Messages	22
Error Responses	23
Enabling and Disabling Telnet	23
Using the Command and Response Table	23
Unsolicited Responses.....	24
Symbol Definitions	24
Command and Response Table for SIS Commands	25
Symbol Definitions for CEC Communications Commands.....	36
Command and Response Table for CEC Communications SIS Commands.....	37
Product Configuration Software	39
Downloading PCS from the Website	39
Starting PCS.....	41
Connecting Using the TCP/IP Panel	43
Updating Firmware	44
Firmware Loader	44
Downloading Firmware Loader	44
Updating Firmware Using Firmware Loader	46
Internal Web Page	48
Accessing the Web Page.....	48
Web Page Components.....	49
Details Panel	49
Status Panel	49
Date and Time Panel.....	50
Network Panel.....	53
Passwords Panel	53
Firmware Panel.....	55
Reference Information	57
Best Practices for Cleaning Your Extron Products	57
Mounting the UCS SW 313	57
Tabletop Use	57
Rack Mounting	58

Introduction

This section gives an overview of the UCS SW 313, describes its features, and provides examples of possible application setups. The following topics are included:

- [About this Guide](#)
- [About the UCS SW 313 Switcher](#)
- [Features](#)
- [USB System Architecture](#)
- [Application Diagrams](#)

About this Guide

This guide describes the UCS SW 313 Collaboration switcher and provides instructions for an experienced installer to set up and operate it.

ATTENTION:

- Installation and service must be performed by authorized personnel only.
- L'installation et l'entretien doivent être effectués uniquement par un électricien qualifié.

In this guide, the terms “UCS,” “UCS SW 313,” and “switcher” are used interchangeably to refer to the UCS SW 313.

About the UCS SW 313 Switcher

The UCS SW 313 is a three-input, one-output, 4K collaboration and presentation switcher with USB device connections for unified communications spaces. The inputs support USB-C and HDMI with USB. The USB-C input provides video and audio, USB data, and 60 watts of power from an internal power supply. Five USB peripheral connections support USB cameras or mics. The HDMI output enables resolutions up to 4K @ 60 Hz, and USB devices connect at rates up to USB 10 Gbps. Auto-switching enables operation in collaboration spaces without a full control system, and it can be controlled via Ethernet, including RS-232 control to a local display.

The UCS SW 313 enables easy connection of USB cameras, microphones, and other peripheral devices to user laptops in small meeting spaces. The UCS SW 313 supports switching up to five USB room devices, two that support rates up to USB 10 Gbps while providing 5 V, 900 mA power, and three that support rates up to High Speed (USB 2) while providing 5 V, 500 mA power per port.

The compact half-rack width enclosure mounts under a table or desk, or in an equipment rack. The UCS SW 313 simplifies integration of AV sources and USB cameras with Teams® and Zoom™ meetings in collaboration spaces.

Features

- **Switches USB devices between USB-C and dual HDMI inputs sent to the output display.**
 - **Inputs:** Two HDMI type A with USB Type B connectors and one USB-C connector
 - **Output:** One female HDMI type A connector
- **Single connection for video, USB data, and power for USB-C source devices.**
- **Supports computer and video resolutions up to 4K/60 @ 4:4:4** — Resolutions up to 4096x2160/60 with 4:4:4 chroma sampling at 8 bits of color.
- **Provides USB device connections up to USB 10 Gbps** — For use with USB cameras or microphones.

- **Provides up to 60 watts of power to a USB-C source** — Supports USB Power Delivery to charge a laptop or other USB-C connected device.
- **HDCP 2.3 compliant** — Ensures display of content-protected 4K video media and maintains interoperability with earlier versions of HDCP.
- **Supported HDMI 2.0b specification features include data rates up to 18 Gbps, HDR, Deep Color up to 12 bit, 3D, and HD lossless audio formats**
- **Support for High Dynamic Range (HDR) video** — Enables greater contrast range and wider color gamut by providing video bandwidth, color depth, and metadata interchange capability for HDR video.
- **Auto-input switching** — Automatically switches to the highest-numbered input with an active video signal or to an active input based on a configured priority.
- **Compatible with Show Me cables** — Show Me cables provide convenient connectivity and user input selection and control for collaboration systems.
- **Display control options including RS-232 and CEC over HDMI connection.**
- **Ethernet monitoring and control** — Enables control and proactive monitoring over a LAN or WAN.
- **Multiple control options including Ethernet, contact closure, front panel, and auto-switching.**
- **EDID Minder automatically manages EDID communication between connected devices** — EDID Minder ensures that all sources power up properly and reliably output content for display.
- **User-selectable HDCP authorization** — Allows individual inputs to appear HDCP compliant or non HDCP compliant to the connected source, which is beneficial if the source automatically encrypts all content when connected to an HDCP-compliant device. Protected material is not passed in non HDCP mode.
- **HDCP Visual Confirmation provides a green signal when encrypted content is sent to a non-compliant display** — A full screen green signal is sent when HDCP encrypted content is transmitted to a non HDCP compliant display, providing immediate visual confirmation that protected content cannot be viewed on the display.
- **HDCP authentication and signal presence LED indicators.**
- **Automatic color bit depth management** — The switcher automatically adjusts color bit depth based on the display EDID, preventing color compatibility conflicts between source and display.
- **Front panel LED indicators for signal presence, HDCP, USB Device connectivity, Auto Switch mode, USB-C power, and unit power** — Provides visual indication of system status for real-time feedback and monitoring of key performance parameters.
- **Front panel security lockout** — Prevents unauthorized use in non-secure environments. Set via PCS.
- **Contact closure remote control with tally output** — Allows for automatic operation by an optional occupancy sensor or remote selection of an input channel by a button panel. +5 VDC is provided to light an LED to indicate the currently selected input.
- **Includes LockIt Plus® cable lacing brackets** — Securely fastens HDMI cables to a device, eliminating risk of disconnection.
- **Extron recommends the USBC Pro 8K Series cable for video applications or the USBC Pro Series for data applications.**
- **Extron recommends the USBC cable for video and data applications under 6 feet (1.8 meters).**
- **Compatible with Extron mounting solutions** — Easy mounting with Extron low-profile and under-desk mounts, under-table kits, and rack-shelf options.
- **1U, half rack width metal enclosure** — Compact, low profile enclosure allows discreet installation within furniture or behind a flat panel display.
- **Internal Extron Everlast power supply** — Provides worldwide power compatibility, with high-demonstrated reliability and low power consumption for reduced operating cost.
- **Extron Everlast Power Supply is covered by a 7-year parts and labor warranty.**

USB System Architecture

A USB system architecture refers to the physical bus topology of USB devices connected to a host device. USB devices include USB hubs, USB peripheral devices, or compound devices (devices with a combination of USB hubs and USB peripheral devices built into it).

The system is organized in a tiered star topology to prevent multiple or circular attachments to the bus (see figure 1). Each tier represents a degree of separation from the host device. Per USB specifications, there are seven supported tiers, starting with the host device (or root hub) occupying the first tier.

NOTE: Do not connect more than five daisy-chained hubs to the root hub. The architecture does not support peripheral devices connected to USB hubs occupying the seventh tier.

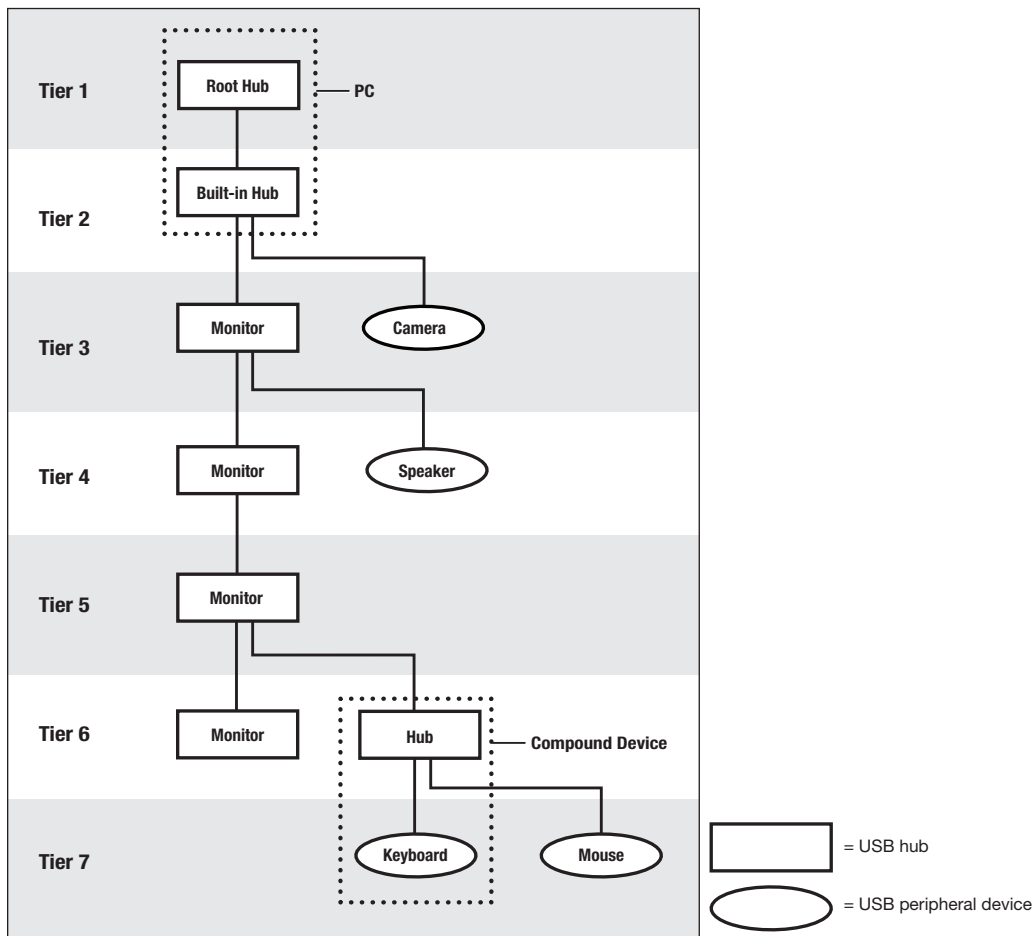

Figure 1. Tiered Star Topology Example for a Computer with Four Monitors

NOTE: Some computers include multiple hubs already connected to each other, occupying multiple tiers in the topology. For example, many computers with USB ports on the front and rear panels or computers with a built-in USB hub and a compound USB peripheral device (such as a touch display) occupy two tiers.

To review the USB system architecture, count all the cascading hubs (including USB hubs enclosed in computers and compound devices) between the host device and the last USB peripheral device.

NOTE: If the host device runs Windows® or macOS™ operating systems, use the following programs to view the hierarchical relationships between USB devices:

- Windows: Device Manager
- macOS: System Profiler or System Information

Application Diagrams

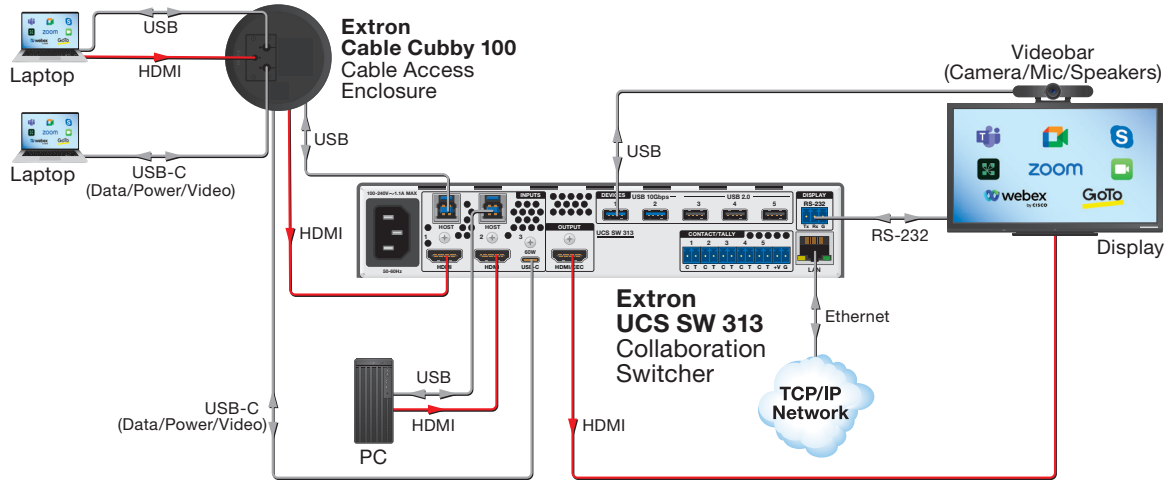

Figure 2. Sample Application for UCS SW 313

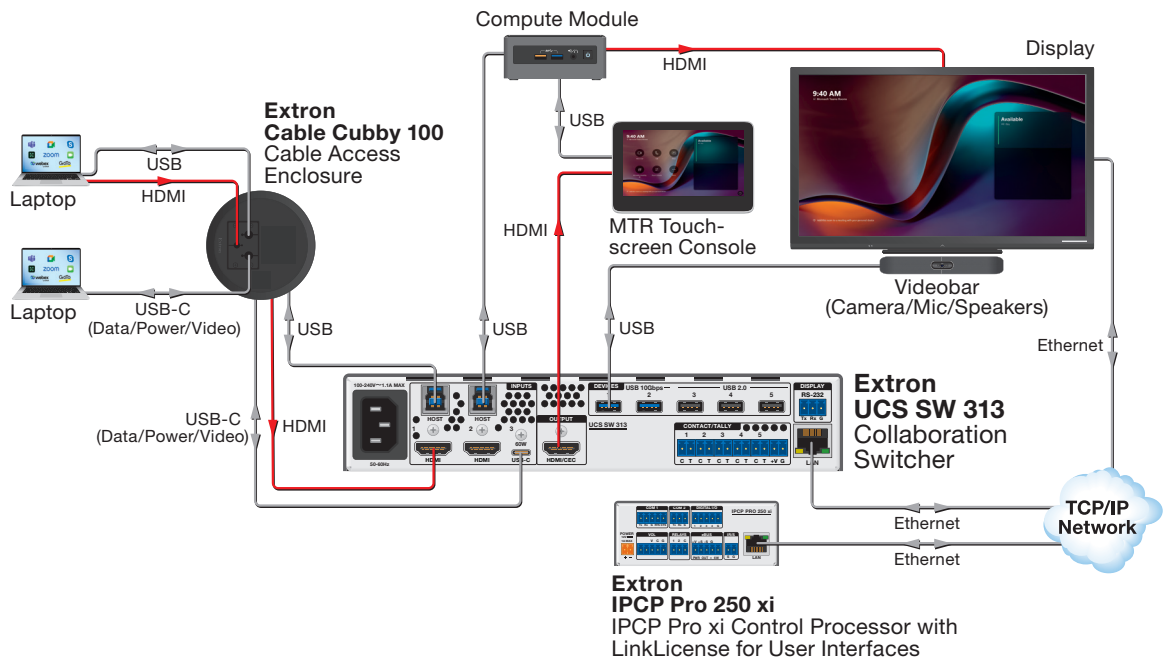

Figure 3. Sample Application for UCS SW 313 — Teams Application

Installation

This section describes the installation and setup of the UCS SW 313 switcher. Topics include:

- [Installation Overview](#)
- [Rear Panel Connections](#)
- [Wiring the CONTACT/TALLY Connectors](#)
- [LockIt Plus HDMI Cable Lacing Bracket Installation](#)
- [Wiring the LAN Port](#)
- [Connecting Multiple UCS SW 313 Switchers in a System](#)

Installation Overview

CAUTION: Remove power from the system before wiring.

ATTENTION : Coupez l'alimentation avant de faire l'installation électrique.

ATTENTION:

- Use electrostatic discharge precautions (be electrically grounded) when making connections. Electrostatic discharge (ESD) can damage equipment, although you may not feel, see, or hear it.
- Prenez des précautions contre les décharges électrostatiques (soyez électriquement relié à la terre) lorsque vous effectuez des connexions. Les décharges électrostatiques (ESD) peuvent endommager l'équipement, même si vous ne pouvez pas le sentir, le voir ou l'entendre.

To install and set up a UCS SW 313 switcher:

1. **Turn off all equipment** and disconnect the unit from the power source.
2. (Optional) **Mount the switcher** on a rack shelf or furniture (see [Reference Information](#) starting on page 57).
3. **Connect video sources and supporting host devices to HDMI inputs 1 and 2:**

Connect an HDMI source and a supporting host device such as a PC or a Next Unit of Computing (NUC) to one or both HDMI and associated host input connectors (see [figure 4](#), [J](#) and [B](#) on page 6).

NOTE: LockIt Plus cable lacing brackets are provided to secure the HDMI cables to the ports to reduce stress on the HDMI connectors and prevent signal loss due to loose cable connections (see [LockIt Plus HDMI Cable Lacing Bracket Installation](#) on page 10).

4. **Connect a USB-C source to the rear panel USB-C connector ([I](#)).**
5. **Connect a video output** — Connect an HDMI display to the HDMI output ([C](#)) to display the transmitted digital image.
6. **Connect peripheral devices** — Connect one or more peripheral USB devices (for example, keyboards or mice) to the USB 3.2 and 2.0 output device ports ([D](#) and [E](#)) as desired.

NOTE: These ports do not provide power if the connected device is getting power from an external power supply.

7. (Optional) **For RS-232 control of a display, connect the RS-232 port** of the display to the DISPLAY port ([F](#)).

8. **Connect a computer** to one of the following UCS ports to configure and control the switcher via SIS commands or PCS:
 - **USB-C CONFIG port** — Connect a USB port on the computer to this USB-C connector via a USB type A to USB-C cable. (see [figure 11](#), **D** on page 17).
 - **LAN port** — Connect an Ethernet cable between the computer and the LAN port via a standard Ethernet cable to control and configure the UCS SW 313 via Ethernet (see figure 4, **G**).
9. **Enable auto-input switching.** Use SIS commands to configure auto-input switching (see the [Auto-switch Mode commands](#) on page 25) (optional).
10. Power on the connected devices.
11. Connect power (**A**) to the switcher.
12. Power on the source devices.

Rear Panel Connections

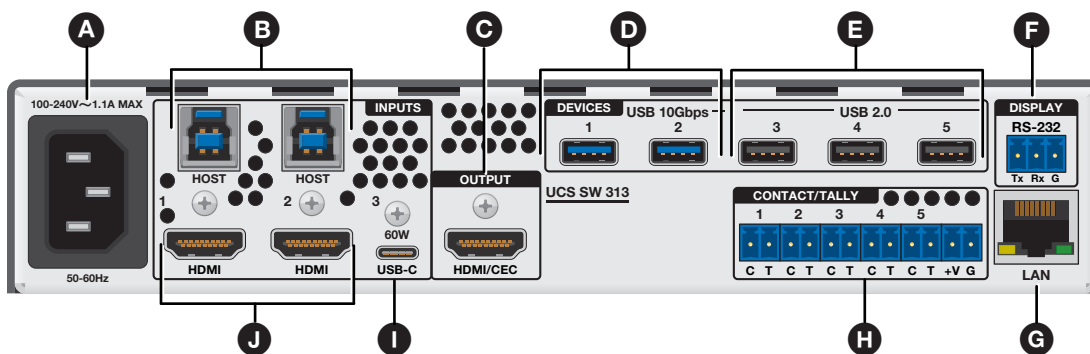

- | | |
|----------------------------------|--------------------------------------|
| A IEC power connector | F RS-232 display control port |
| B USB host ports | G LAN port |
| C HDMI/CEC output | H Contact/Tally ports |
| D USB SS 10G device ports | I USB-C input |
| E USB 2.0 device ports | J HDMI inputs |

Figure 4. UCS SW 313 Rear Panel

- A** **IEC power connector** — Connect a 100-240 VAC IEC power cable to this connector to provide AC power to the switcher.
- B** **USB host ports** — Connect PCs or other USB host devices to these female USB type B connectors for USB 3.2 input in support of HDMI inputs 1 and 2 (**J**).
- C** **HDMI/CEC output** — Connect an HDMI (or DVI with an appropriate adapter) output device to this connector for HDMI video with CEC and embedded audio. The output supports resolutions up to 4096 x 2160 @ 60 Hz, 8-bit, with 4:4:4 chroma sampling.

NOTE: Use the provided LockIt Plus Plus Lacing Brackets to secure the HDMI connectors (see [LockIt Plus HDMI Cable Lacing Bracket Installation](#) on page 10).

- D** **USB SS 10G device ports** — Connect USB 3.2, 2.0, or 1.x devices and HIDs (peripherals such as keyboards, mice, or storage drives) to these blue USB ports. USB 3.2 signals from the inputs are routed to these ports. Each port provides up to 5 V, 900 mA of power to the connected devices.

NOTE: These ports do not provide power if the connected device is receiving power from a separate power supply.

- E USB 2.0 device ports** (see [figure 4](#) on page 6) — Connect USB 2.0 or 1.x devices to these black USB Type A ports. USB 2.0 and 1.x signals from the inputs are routed to these ports. Each port provides up to 5 V, 500 mA of power.

NOTE: These ports do not provide power if the connected device is receiving power from a separate power supply.

- F RS-232 display control port** — Connect this port to the RS-232 connector of a display to control the display. The port can be configured using PCS (see the *UCS SW 313 and UCS 303 Help File*) to control the display in the following modes 0, 1, or 2 (see the table below). See figure 5 to wire this port.

Mode	Function
0	Disabled
1	Built-in internal control of RS-232 capable endpoints such as displays without the need of an external control processor. Custom RS-232 commands can be sent via PCS out of this port based on events or triggers (such as contact closure or video input signal presence). See the <i>UCS SW 313 and UCS 303 Help File</i> , Control Configuration section, for the procedure.
2	External control of RS-232 capable endpoints such as a display using Ethernet to RS-232 insertion. This mode enables serial commands to be passed from the Ethernet port to this RS-232 port. It enables control of endpoints such as the display without needing to run additional cabling from the control processor to the endpoint.

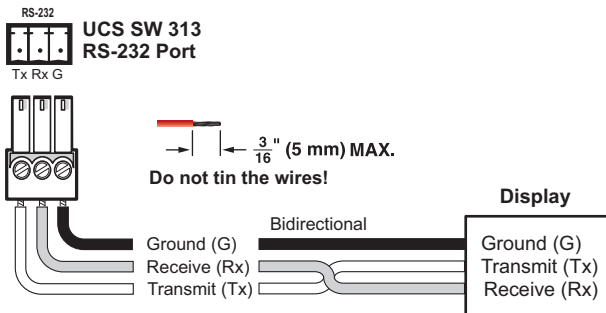

Figure 5. Wiring for RS-232 Display Control

- G LAN port** — Connect the switcher to an active network using an Ethernet cable, terminated with an RJ-45 connector. To wire this port, see [Wiring the LAN Port](#) on page 11.

NOTES:

- If the UCS is set as a DHCP client and cannot locate a DHCP server, the port is set to a local address link.
- All Ethernet interfaces on the UCS SW 313 support up to 10/100/1000 Mbps (Gigabit Ethernet).

- H Contact/Tally ports** — (Optional) Wire a push-button switch or other contact closure device to pin C (contact) and to the shared pin G (ground) of any of these 2-pole connectors (see [Wiring the CONTACT/TALLY Connectors](#) on page 8 for more information). These ports are configured via PCS (see the *UCS SW 313 and UCS 303 Help File*).

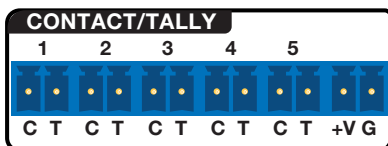

Figure 6. CONTACT/TALLY Ports

Alternatively, wire a Show Me (SM) cable to the C and T pins (see [Connecting Using a Show Me Cable](#) on page 10 for connection instructions).

- ① **USB-C input** (see [figure 4](#) on page 6)— Connect a USB-C source device, such as a laptop or PC, to this USB-C connector. This port can be configured in DP Alt Mode via SIS commands to convert USB-C signals from the connected PC to DisplayPort. Once USB-C has been converted to DP, four DisplayPort lanes are available. The DisplayPort signal is then converted to TMDS, to be output on the HDMI output port.

The USB-C input port provides up to 60 watts of power to the connected source. If the source requires more than 60 watts, this port keeps the device functioning but does not charge it. If the source is connected to an external power supply, the UCS SW 313 does not send power to it.

- ② **HDMI input** — Connect an HDMI (or DVI with appropriate adapters) video input source to these female HDMI ports for HDMI video with embedded audio.

NOTE: LockIt Plus cable lacing brackets are provided to secure the HDMI cables to the ports. This reduces stress on the HDMI connectors and prevents signal loss due to loose cable connections (see [LockIt Plus HDMI Cable Lacing Bracket Installation](#) on page 10 for more information).

Wiring the CONTACT/TALLY Connectors

To make input selections via contact closure, short the C pin of each port momentarily to the ground pin G. Input switching occurs immediately on contact, and **not** on the release. To enable contact closure, connect a push-button contact closure device to a CONTACT/TALLY connector (see [figure 4](#), ④ on page 7).

To identify the currently selected input when the front panel buttons are not visible, connect a device such as an LED to the CONTACT/TALLY connector and to the +V connector (see [figure 7](#), ③ on page 9). When the input being used is selected, the corresponding TaLly Out pin shorts to ground, activating the connected indicator.

ATTENTION:

- The length of the exposed wires in the stripping process is critical. The ideal length is 3/16 inch (5 mm). If the exposed portion is longer, the wires may touch, causing a short circuit between them. If the exposed wires are shorter, they can be easily pulled out, even if tightly fastened by the captive screws.
- La longueur des câbles exposés est primordiale lorsque l'on entreprend de les dénuder. La longueur idéale est de 5 mm (3/16 inches). S'ils sont un peu plus longs, les câbles exposés pourraient se toucher et provoquer un court circuit. S'ils sont un peu plus courts, ils pourraient sortir, même s'ils sont attachés par les vis captives.
- Do not tin the wires. Tinned wires are not as secure in the captive screw terminals <connector> and could pull out.
- Ne pas étamer les câbles. Les câbles étamés ne sont pas aussi bien fixés dans les terminaisons des <connecteurs> à vis captives et pourraient sortir.
- The installation must always be in accordance with the applicable provisions of National Electrical Code ANSI/NFPA 70, article 725 and the Canadian Electrical Code part 1, section 16.
- Cette installation doit toujours être conforme aux dispositions applicables du Code américain de l'électricité (National Electrical Code) ANSI/NFPA 70, article 725, et du Code canadien de l'électricité, partie 1, section 16.

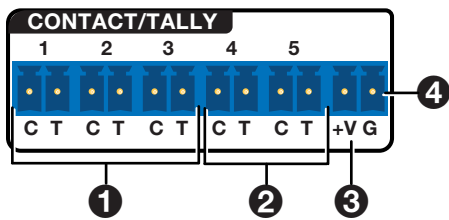

Figure 7. CONTACT/TALLY Ports

The contact closure ports have the following functions:

Contact Closure Pin Number	Function
1	Input 1
2	Input 2
3	Input 3
4	AUX
5	AUX
G	Ground

- Ports 1-3** (see figure 7, ❶) — These can be configured as a mutually exclusive input group to allow for input switching via Show Me (SM) cables. The selected input tally illuminates steadily when displayed, or blinks when muted.

Optionally, successive contact closures of the current input can be configured to toggle AV mute or output sync mute.

If **None** is selected, contact events broadcast unsolicited SIS responses for action via external control system. Tally ports are configured via an external control system.
 - Ports 4 and 5** (❷) — These contact ports can be configured as follows via PCS (see the *UCS SW 313 and UCS 303 Help File*):
 - None** — contact events broadcast unsolicited SIS responses for action via an external control system. Tally ports are configured via external control system.
 - Single switch** — Individual contact input triggers user-defined events (such as Volume Up), along with an optional repeat rate for press and hold actions (such as ramping volume up several steps). The Tally illuminates when the contact port is closed.
 - Toggle switch** — Individual contact input toggles between two sets of user-defined events (such as mute and unmute). The Tally illuminates when the contact port is closed.
 - Group switch** — Pairs two contact inputs to act as a mutually exclusive pair, which trigger events such as system on vs. system off. Tally on the last activated contact remains illuminated.
 - +V connector** — The +V pin constantly outputs +5 VDC power with 200 mA total (shared between pins). Use this pin when power is needed for external Tally LEDs, such as those on the Extron CCB 30 contact closure remote.
- Wire and connect provided 2-pole plugs to the CONTACT/TALLY connectors 1 through 5 as desired (❶ and ❷).
 - Connect contact input and tally output devices to the pin pair for each input. To wire the contact ports:
 - To enable input switching via contact closure, connect a push-button contact closure input device to pin C of the desired contact port, and to the G (ground) pin (❹).
 - To identify the currently selected input when the front panel buttons are not visible, connect an indicator device, such as an LED, to tally output pin T of the same pair of pins.

When the input being used is selected, the corresponding Tally pin shorts to ground, which activates the connected indicator.

3. Insert the power wires for the contact indicator devices into the +V connector (see [figure 7](#), ③ on page 9).
4. Press the button on the contact closure device to switch the connected input to the output.

Connecting Using a Show Me Cable

The CONTACT/TALLY connectors can also be used with Extron Show Me cables. Figure 8 shows how to wire a Show Me cable to a contact/tally input.

For each Show Me cable:

- Connect the **red** (contact) pigtail to the C pin corresponding to the input being used.
- Connect the **black** (tally out) pigtail to the T pin.

NOTE: For a Show Me cable, the ground source needed to trigger the contact and the voltage to drive the tally indicator are supplied by HDMI source device. Therefore, it is not necessary to connect the cable to a G (ground) pin.

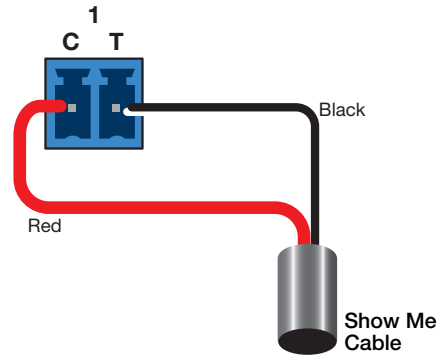

Figure 8. Show Me Cable Connecting Contact and Tally Ports

LockIt Plus HDMI Cable Lacing Bracket Installation

The Extron LockIt Plus lacing bracket secures a standard HDMI cable to most HDMI devices.

NOTE: The HDMI device must have an HDMI connection mounting screw for this bracket to be used.

Follow these instructions to secure the HDMI connectors to the unit with the provided LockIt Plus lacing brackets:

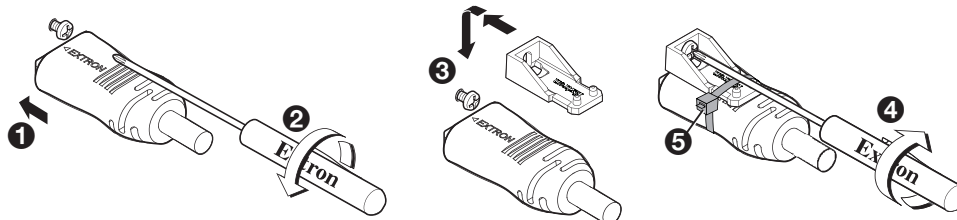

Figure 9. LockIt Plus Installation Diagram

- 1 **Plug in the cable** – Connect the HDMI cable to the HDMI port.
- 2 **Loosen the screw** – Slightly loosen the mounting screw (do not remove it).
- 3 **Attach the bracket** – Place the bracket over the screw.
- 4 **Tighten the screw** – Do not overtighten the connector mounting screw.
- 5 **Secure the cable** – Tighten the tie wrap around the connector and bracket, and cut off the extra length.

ATTENTION:

- Do not overtighten the HDMI connection mounting screw. The shield to which it is fastened is very thin and can easily be stripped.
- Ne serrez pas trop la vis de montage du connecteur HDMI. Le blindage auquel elle est attachée est très fin et peut facilement être dénudé.

Wiring the LAN Port

Ethernet control enables configuration and control of the UCS SW 313 from a remote location using SIS commands (see [Command and Response Table for SIS Commands](#) starting on page 25), PCS (see the *UCS SW 313 and UCS 303 Help File*), or the embedded web pages (see [Internal Web Page](#) starting on page 48).

Default LAN settings:

- **Rear panel LAN IP Address** — 192.168.254.254
- **Front panel USB-C port IP address** — 203.0.113.22 @ port 22023
- **Subnet mask** — 255.255.255.0
- **Gateway** — 0.0.0.0
- **DNS** — 127.0.0.1
- **User name** — admin
- **Password** — The UCS SW 313 unit serial number
- **DHCP** — Off

NOTE: The initial factory configured passwords for all accounts on this device have been set to the device serial number. Passwords are case sensitive. In the event of an absolute system reset, the passwords are reset to extron.

Protocols:

The following protocols are supported:

HTTP (not secure)	DHCP
HTTPS	DNS
SSH	ICMP
SFTP	IPv4
SMTP	SNMP
NTP	UDP
Discovery Service	Extron Global Messaging

ATTENTION:

- Do not connect this device to a telecommunications network.
- Ne connectez pas ces appareils à un réseau de télécommunications.

To wire the LAN connector:

- Use a straight-through cable for connection to a switch, hub, or router.
- Use a crossover cable or a straight-through cable for connection directly to a PC. Wire the connector as shown in figure 10.

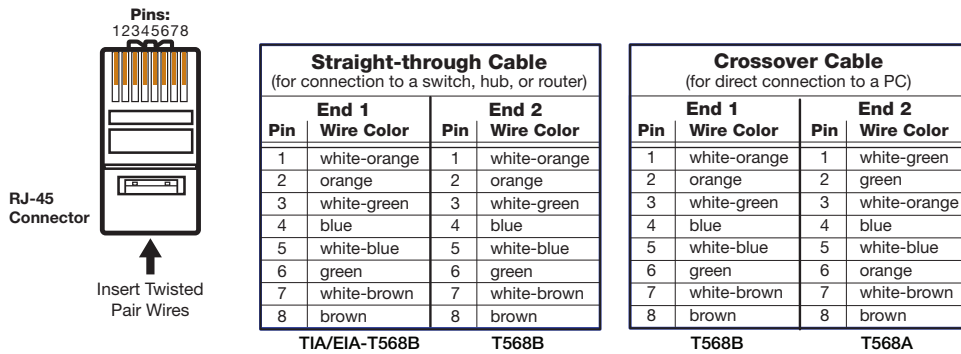

Figure 10. Wiring for Ethernet Control

Connecting Multiple UCS SW 313 Switchers in a System

The USB specification states that a maximum of five hubs (or five UCS SW 313 switchers) can be connected in a series.

NOTE: Do not exceed five cascaded hubs and a total of 127 peripheral devices in the entire system.

Operation

This section describes the operation of the UCS SW 313. Topics include:

- [Front Panel Features](#)
- [Powering on the Switcher](#)
- [Selecting an Input](#)
- [Auto-switching](#)
- [Resetting](#)
- [Front Panel Lock Mode \(Executive Mode\)](#)
- [HDCP](#)
- [Color Bit Depth](#)
- [USB-C Input](#)
- [RS-232 Signal Insertion](#)

Front Panel Features

Figure 11 shows the front panel LEDs and controls of the UCS SW 313.

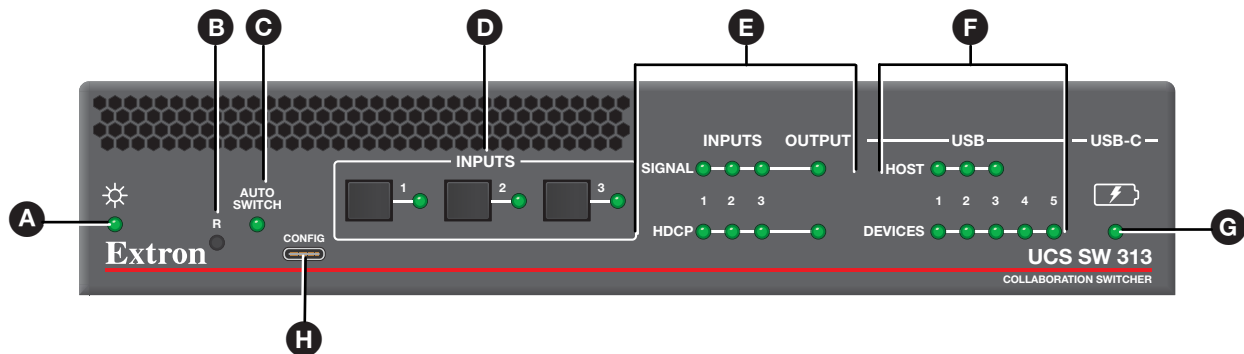

- | | | |
|------------------------------|--|----------------------------|
| A Power and Reset LED | D Input buttons and LEDs | G USB-C power LED |
| B Reset button | E Input and output signal and status LEDs | H USB-C CONFIG port |
| C Auto Switch LED | F USB status LEDs | |

Figure 11. UCS SW 313 Front Panel

- A** **Power and reset LED** — Lights when the unit has power.

While the R (reset) button (see figure 11, **B**) is pressed and held, this LED blinks every 3 seconds to indicate the level of reset initiated if the button is released and momentarily pressed again at that point (see [Resetting](#) on page 16 for more information).

- B** **Reset button** — Using an Extron Tweaker (provided) or other small screwdriver or stylus, press the R button to reset the unit. There are three available reset modes:
- Press and hold the **Reset** button for 3 seconds to return all settings to the factory default, excluding IP settings.
 - Press and hold the **Reset** button for 6 seconds to return all settings to default, including IP settings.
 - Press and hold the **Reset** button while applying power to return all settings to default, and revert the firmware to the factory installed version.

NOTE: You can also reset the switcher to its factory default settings using SIS commands (see [Resets](#) on page 35) or PCS (see the *UCS SW 313 and UCS 303 Help File*).

- C** **Auto Switch LED** — Lights when auto-input switching is in effect (see [Auto-switching](#) on page 15). The switcher can be configured via SIS commands or PCS to automatically select the lowest to highest numbered input with an active signal (see [Auto-switch Modes](#) on page 15).

- D Input buttons and LEDs** (see [figure 11](#) on page 13) — Press these buttons to select an input to switch to the output. When an input is selected, the LED at the right of the input button lights. If auto-input switching is in effect, the input buttons are disabled, but the LEDs continue to light to indicate the selected input (see [Auto-switching](#) on page 15).
- E Input and output signal and status LEDs** — These stacked green LEDs light as follows:
 - **SIGNAL LEDs** — Light when active video content is detected on the corresponding input or the output.
 - **HDCP LEDs** — Light when the corresponding input or the output signal is HDCP encrypted.

NOTES:

- HDCP is authenticated on each input regardless of the currently selected source.
- If the source device connected to the selected input is HDCP encrypted (requires HDCP authentication), the corresponding signal LED may not light unless HDCP has been authenticated.

- F USB status LEDs** — These stacked green LEDs light as follows:
 - **HOST LEDs** — Light to indicate the USB host status for the corresponding input.
 - **DEVICES LEDs** — Light when a peripheral device is connected to the corresponding output port and has been enabled by the selected host.
- G USB-C power LED** — Lights to indicate switcher power delivery to the connected USB-C source.
- H USB-C CONFIG port** — Connect the computer to this USB-C connector for product configuration using Extron SIS commands or PCS.

Powering on the Switcher

To power on the UCS SW 313:

1. Connect all input and output devices to the rear panel ports on the switcher (see [figure 4](#) on page 6).
2. Power on the HDMI output device.
3. Connect the power to the IEC power connector port on the rear panel.

After approximately 4 seconds, the following happens:

- The unit performs a self-test, during which the front panel LEDs each blink once in sequence from left to right. When the self-test completes, the LED for the most recently selected input remains lit.
 - The switcher reads the available EDID information from the connected output device and writes it to memory on each input. When power is removed, these settings remain in memory and are in effect when power is reapplied.
4. Power on the input devices.

Selecting an Input

Switching an input to the output can be done by the following methods:

- **Front panel buttons** — Press the desired input button on the front panel (ensure that auto switching is not enabled). The LED corresponding to the selected input button lights.
- **Auto-switch modes** — Configure the UCS to select the active, connected input based on detection of an active video signal. This can be done via SIS commands (see [Auto-switching](#)).

NOTE: While the UCS SW 313 is in any auto-switch mode, inputs can still be manually selected via front panel buttons or SIS. This allows the user to switch to any input during usage and not rely on auto-switching. Making a manual switch when the unit is in auto-switch mode does not disengage auto-switch.

- **Contact closure** — Attach a contact closure switch or a Show Me cable to a CONTACT/TALLY connector to enable input switching via contact closure. Use the connected switch to select the input (see [Wiring the CONTACT/TALLY Connectors](#) on page 8).
- **Remote control** — Inputs can be selected using SIS commands or PCS (see [Input Selection commands](#) starting on page 25 or the *UCS SW 313 and UCS 303 Help File*).

Auto-switching

Auto-switching allows the UCS SW 313 to automatically select the active, connected input based on detection of an active video signal (TMDS clock activity). If two or more inputs are active, the highest-numbered input port with an active signal is selected (for example, input 3 on a UCS SW 313 switcher).

When auto-input switching is in effect, the green Auto Switch LED on the front panel lights. (Manual switching is still available.)

Auto-switch Modes

The UCS SW 313 switchers provide three auto switch modes, which can be selected via SIS commands (see the [Auto-switch Mode commands](#) on page 25) and PCS (see the *UCS SW 313 and UCS 303 Help File*).

- **Mode 0 (disabled mode)** — Auto-input switching is disabled. Inputs must be selected via front panel buttons, SIS, or PCS.
- **Mode 1 (user-assigned mode)** — The switcher selects the input to which you assign priority (via SIS commands or PCS). If no priority is assigned, the switcher selects the active input with the highest number (default user selection).
- **Mode 2 (input memory priority mode)** — The switcher selects the most recently applied input, and retains a history of the order in which active inputs are connected to the unit. If an active input is removed, the switcher switches to the most recently selected input.
- **Mode 2 timeout** — Using SIS commands or PCS, you can set the number of seconds the switcher delays between when the current input is removed and the unit switches to the most recent previous input. The timeout duration range is 0-500 seconds in 1-second increments. The default is 3 seconds.

Auto-switch Type

The Auto-switch type feature allows you to select which signal is automatically switched. If front panel input buttons are pressed while Auto-switch is enabled, switched signal follows the type that is set. Front panel button presses override the current selected input and switch all signals. However, they do not disable the Auto-switch mode and type.

- **Audio, video, and USB** — When Auto-switch is enabled, audio, video, and USB signals all switch together. This type monitors the active TMDS clock (HDMI input) or AUX channel (USB-C inputs) signal.
- **Audio and video only** — When Auto-switch is enabled, only audio and video signals switch. USB stays enumerated with the user-selected host. This type monitors the active TMDS clock (HDMI input) or AUX channel (USB-C inputs) signal.

Resetting

The recessed **Reset** button on the front panel can initiate three types of reset.

ATTENTION:

- Review the reset types carefully. Using the wrong reset may result in unintended loss of flash memory programming, port reassignment, or unit reboot.
- Étudier de près les différents modes de réinitialisation. Appliquer le mauvais mode de réinitialisation peut causer une perte inattendue de la programmation de la mémoire flash, une reconfiguration des ports ou une réinitialisation du processeur.

Reset Mode Summary			
Mode	Activation	Result	Purpose and Notes
Use Factory Firmware (Run Universal Boot Code)	Hold in the recessed front panel RESET button while applying power to the unit. The power LED blinks twice for confirmation upon power up.	The device reverts to the factory default firmware for a single power cycle.	Temporarily boot up the unit running only the universal boot code, then install the desired firmware. Use this in the event that a firmware update has failed or if incompatibility issues arise with user-loaded firmware
	<p>NOTE: Do not continue to operate the control processor using only the boot code. The unit requires a full firmware package in order to be fully operational. To use the firmware version with which the unit shipped, upload that version again.</p>		
Reset Network Settings	Hold in the RESET button until the power LED blinks twice (once at 3 seconds, again at 6 seconds). Then, release and press the RESET button again within 1 second.	<ul style="list-style-type: none"> • Sets the following back to factory default: <ul style="list-style-type: none"> • Port mapping IP address (192.168.254.254). • Subnet mask address (255.255.255.0). • Gateway IP address (0.0.0.0). • Enables ARP capability. • Turns DHCP off and on. 	Use this mode to reset all IP settings back to factory defaults. Equivalent to SIS command 1ZQQQ (see Resets on page 35).
Reset to Factory Default	Hold in the RESET button until the power LED blinks three times (once at 3 seconds, again at 6 seconds, again at 9 seconds). Then, release and press the RESET button again within 1 second.	<ul style="list-style-type: none"> • Performs a complete reset to factory defaults (except the firmware). • Does everything the Reset Network Settings mode does. • Clears port configurations. • Resets all IP options. • Clears all user settings. • Resets all passwords. • Clears all files from the unit. 	Start over with configuration and uploading. This is equivalent to SIS command ZQQQ. This reset removes the initial serial number password and sets it to extron.

Front Panel Lock Mode (Executive Mode)

Front panel lock mode (executive mode) locks and disables all front panel controls (Ethernet and USB control remain available). Putting the switchers in lock mode enhances security by protecting against inappropriate or accidental changes to settings. If a front panel button is pressed during lock mode, all front panel LEDs blink once.

Lock mode can be configured via SIS commands (see [Set front panel lock mode commands](#) on page 30) or PCS (see the *UCS SW 313 and UCS 303 Help File*). The following lock mode options are available:

- Lock entire front panel
- Disable lock mode (default). All front panel controls are accessible.

To lock or unlock the front panel:

1. The switchers can be locked or unlocked via SIS commands, connecting through the front panel USB port or rear panel LAN port.
2. Executive mode is retained after a power cycle. Any reset mode unlocks the unit.

HDCP

Inputs

The HDMI input negotiates and authenticates HDCP with the source device if the source requires HDCP encryption. The authentication process is repeated whenever the stored EDID is changed or updated, which is indicated by pulling HPD low.

HDCP support can be disabled using SIS commands (see [Input HDCP Authorization](#) on page 26). When the HDCP support is disabled, the input appears as a non-HDCP compliant device to a connected source.

Output

The output is pre-authenticated and encrypted, if required by the connect source. If the output requires encryption but the connected sink device cannot be authenticated, the output displays a green screen.

The following output encryption modes can be selected via SIS commands or PCS:

- **Follow input** — Output is always authenticated but only encrypted when required by input. HDMI authentication attempts are continuous. DVI authentication occurs for a maximum of 10 seconds, then fails.
- **Always encrypt output** — Output is always authenticated and encrypted regardless of whether the input video is encrypted or not. HDMI authentication attempts are continuous. DVI authentication occurs for a maximum of 10 seconds, then fails.

HDCP Authorized Setting

The HDCP Authorized setting, configurable via SIS commands, is for devices such as Mac computers, iPhones, iPads, and some Windows sources that always encrypt their output, if the downstream sink is HDCP compliant.

- **HDCP Authorized On** — The HDMI inputs indicate to the sources that they are capable of handling HDCP content.

When an encrypted or unencrypted source is connected, the video is passed through the system.

- **HDCP Authorized Off** — The HDMI inputs indicate to the sources that they are not capable of handling HDCP content.

When a Macbook, or any of the other devices listed above, is connected, the output video is unencrypted.

When a source playing content that requires video encryption (for example, Blu-ray) is connected, the source does not output video.

HDCP Encryption

The HDCP Encryption status can be viewed via SIS command and the front panel HDCP LED Indicators.

- **Inputs** — All inputs support content encrypted using HDCP 1.x or HDCP 2.2
- **Output** — The output supports encrypting content using HDCP 1.x or HDCP 2.2.

HDCP Notification

HDCP notification provides an indication that encrypted content is trying to be displayed on a non-HDCP compliant sink device. The requirements for the notification can be configured for each output via SIS command (N HDCP).

- **HDCP Notification Enabled** — A green screen is displayed on the output when the input signal is encrypted and the display is not HDCP compliant.
- **HDCP Notification Disabled** — A black screen is displayed when the input signal is encrypted and the display is not HDCP compliant.

Color Bit Depth

There are two options for color depth and deep color support. Color bit depth is configurable for each output via SIS commands (see the **Output Color Bit Depth** commands on page 26) or PCS (see the *UCS SW 313 and UCS 303 Help File*).

- **Automatic** — By monitoring the EDID of the sink, the UCS SW 313 switcher determines the best color depth that is supported by the sink. If the color bit depth of the signal is supported, the signal passes unaltered. If the color bit depth is not supported, then the signal is truncated to the maximum supported by the sink.
- **Force 8-bit** — When output is set to force 8-bit color bit depth, the unit always outputs 8-bit color bit depth.

USB-C Input

The USB-C input supports USB data, audio, video, and USB power delivery. This input is a USB 3.2 port, supporting up to 10 Gbps and is backwards compatible with USB 2.0, 1.1, and 1.0.

DisplayPort Alt Mode

The DP Alt Mode is required for signal conversion to DisplayPort. After USB-C has been converted to DP via DP Alt Mode, four DisplayPort lanes are available. The DisplayPort signal is then converted to TMDS.

The USB-C input host controller can be configured to operate in one of two modes to support a combination of high resolution video and USB via SIS. The four data lanes used and shared by USB 3.x data and DP Alt Mode can be configured to operate in one of the two modes:

- **USB 3.x + USB 2.0 + 4k/30 video — mode 1 (default)**
The USB-C input host controller is configured so that two high speed data Lanes operate in HBR2 mode (5.4 Gbps x 2 lanes = 10.8 Gbps). The two other high speed data lanes are used for USB 3.2 (5 to 10 Gbps) operation.
- **4k/60 video + USB 2.0 only — mode 2**
If the system requires just video and USB 2.0 (no USB 3.x data), then 4k @ 60 Hz can be supported on the USB-C input by configuring it to operate in a mode so that all four high speed lanes for DisplayPort Alt Mode support HBR2 (5.4 Gbps x 4 lanes = 21.6 Gbps).

USB-C Power Delivery

The USB-C port provides up to 60 watts of power to connected source. For sources that require greater than 60 watts of power, it is able to keep the source active, but cannot charge it. If the source is already connected to an external power supply, the UCS SW 313 does not send power to the source.

Power profile:

The unit supplies all identified output voltages of 5 VDC, 9 VDC, 15 VDC, and 20 VDC per the *USB Power Delivery Specifications*.

RS-232 Signal Insertion

To control a display connected to the rear panel Display RS-232 port, the UCS SW 313 allows insertion of RS-232 control signals onto the cable that connects the display to the port. Commands can then be sent via contact closure to control the display (for example, turn the volume up and down).

PCS provides controls to set the serial port parameters and the insertion port starting point. After the display is connected, set up RS-232 insertion as described in the *UCS SW 313 and UCS 303 Help File*, provided with PCS.

The control signals can be inserted in the following ways:

- **Ethernet to RS-232 insertion** (see Ethernet to RS-232 Insertion) — A control signal conveying commands from a control device such as an IPCP 250 is applied to the UCS SW 313 LAN port, then routed to the Display RS-232 port. The RS-232 commands are inserted onto the cable connecting the Display RS-232 port to a display. The RS-232 port can support up to a 115,200 baud rate (the default is 9600 baud).
- **Captive screw insertion** (see [Captive Screw Signal Insertion](#) on page 21) — SIS commands are entered via PCS (see the *UCS SW 313 and UCS 303 Help File*) and sent to the UCS SW 313 LAN port. The commands are then inserted onto the cable connected to the Display RS-232 port and applied to the connected display.

Ethernet to RS-232 Insertion

Figure 12 shows an example of an Ethernet to RS-232 insertion, in which an Extron controller provides control of a display via the UCS SW 313.

Configure this type of insertion as follows:

1. Connect a cable from the control system to the LAN port of the UCS SW 313, directly or via a network.
2. If necessary to match the device to be controlled, configure the RS-232 port protocol (baud rate, parity, data bits, and stop bits) using PCS (see the *UCS SW 313 and UCS 303 Help File*).

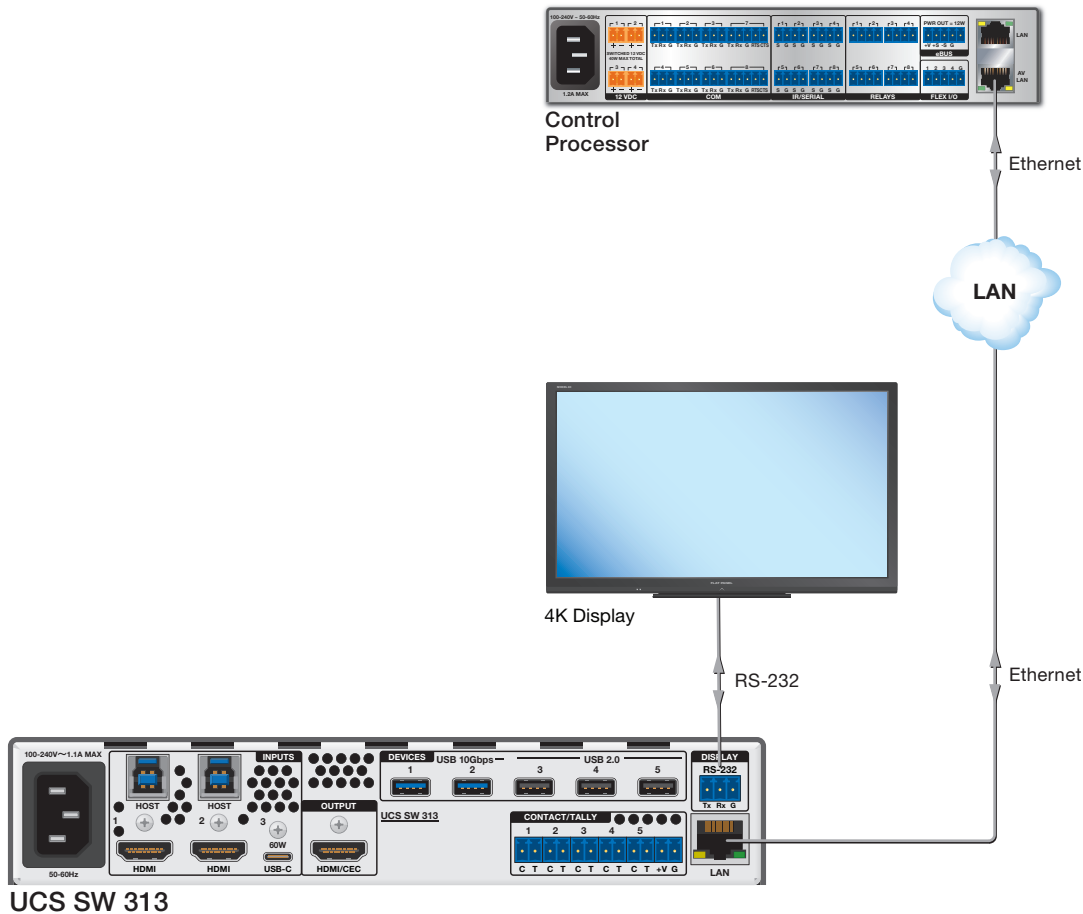

Figure 12. Typical Ethernet to RS-232 Insertion to a Display

3. Connect a serial cable from the display to the UCS SW 313 Display RS-232 port.

Port number

For RS-232 insertion, the insertion port number must be stated from a specific UART start point. This number is entered as the port number when communication is established with the insertion port. Figure 12 shows the default settings for RS-232 insertion.

Output	Output Name	Insertion Port	Method for RS-232	Baud Rate
1	Output 1	2000	Built-in (internal) control	9600

Starting Port:

Starting Port Range: 1024-65533

Figure 13. RS-232 Insertion PCS Screen Showing Defaults

Example: In the UCS SW 313 example below, 2069 was assigned as the output port number, which appears in the Insertion Port column.

Output Port	Output Name	Insertion Port	Method for RS-232	Baud Rate
1	Output 1	2069	Ethernet	9600

The insertion port number can be changed using PCS (see the *UCS SW 313 and UCS 303 Help File* for the procedure).

Captive Screw Signal Insertion

Figure 14 shows an example of a typical captive screw Ethernet insertion, in which a computer running PCS provides control of a display via the UCS SW 313. Configure this type of insertion as follows:

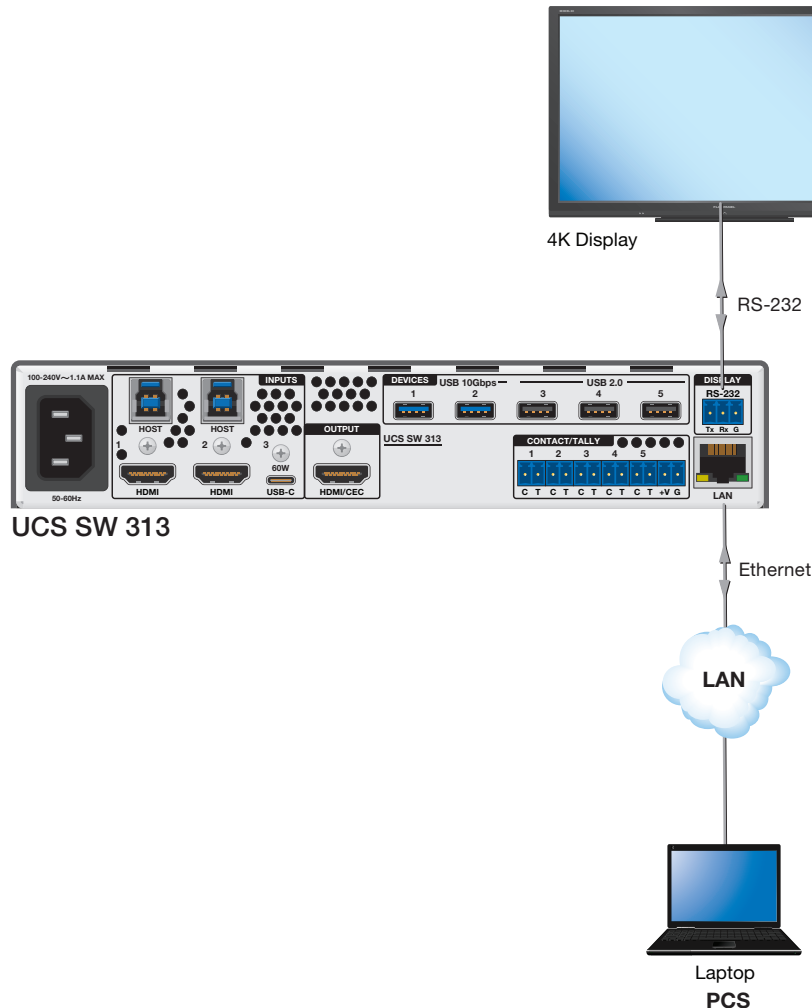

Figure 14. Typical Captive Screw Insertion to a Display

1. Connect the computer to the LAN port of the UCS SW 313.
2. Connect the RS-232 cable from the UCS SW 313 Display RS-232 connector to the RS-232 port of the display to be controlled.

SIS Communication and Control

This section describes remote operation of the UCS SW 313. Topics include:

- [Using the Simple Instruction Set Commands](#)
- [Enabling and Disabling Telnet](#)
- [Using the Command and Response Table](#)
- [Command and Response Table for SIS Commands](#)
- [Command and Response Table for CEC Communications SIS Commands](#)

Using the Simple Instruction Set Commands

The UCS SW 313 can be remotely set up and controlled via Extron SIS commands issued from a computer or control system via the rear panel LAN port (see [figure 4](#), [G](#) on page 6) or the front panel USB-C CONFIG port (see [figure 11](#), [H](#) on page 14).

Host-to-switcher Communications

SIS commands consist of one or more characters per field. No special characters are required to begin or end a command sequence. You can enter these commands from your computer using a communication software program. When the switcher determines that a command is valid, it executes the command and sends a response to the host device. Responses from the UCS SW 313 to the host computer end with a carriage return and a line feed (CR/LF = `↵`), which signals the end of the response character string. A string is one or more characters.

Use one of the following methods to establish communication between the host and the UCS:

- **Ethernet** — Ensure the unit is connected to the host via the rear panel LAN port. To enter SIS commands, use a secure communication utility that supports Secure Shell (SSH). Enter the UCS SW 313 IP address where requested, and use 22023 as the port number.
- **IP over USB** — Connect the host to the front panel USB-C CONFIG port. To enter SIS commands, use a secure communication utility that supports Secure Shell (SSH). Enter 203.0.113.22 for the IP address where requested and 22023 as the port number.

Switcher-initiated Messages

When a local event such as a front panel selection or change in signal status takes place, the switcher responds by sending a message to the host, indicating what change has occurred. No response is required from the host. The switcher sends the following message when it is first powered on:

© Copyright 20nn, Extron Electronics, UCS SW 313, Vx.xx, 60-nnnn-nn↵

- Vx.xx is the firmware version number.
- 60-nnnn-nn is the model part number.

Error Responses

If the switcher is unable to execute a command it receives, it returns an error response to the host. The following error response codes can be sent:

- E06 – Invalid channel change (in auto-switch mode)
- E10 – Invalid command
- E13 – Invalid parameter
- E28 – Bad Filename/File not found

Enabling and Disabling Telnet

By default, Telnet on port 23 is disabled. If it becomes necessary to enable Telnet communication, remap the Telnet port as described below. (The `↵` symbol shown here represents a carriage return with a line feed, in other words, pressing the <Enter> key.)

To enable Telnet:

1. Use a SecureShell (SSH) client (such as PuTTY) to connect to the switcher over port 22023.
2. Enter the following SIS command to remap the Telnet port to 00023:

```
Esc]Z23PMAP↵
```

To disable Telnet:

To disable Telnet communication in order to require the SSH secure communication protocol to transmit SIS commands, remap the Telnet port as follows:

1. Use an SSH client (such as PuTTY) to connect to the switcher using SSH over port 22023, or
Use a Telnet client (such Extron DataViewer) to connect to the switcher over port 23.
2. Enter the following SIS command to remap the Telnet port to 00000.

```
Esc]Z0PMAP↵
```

This disables Telnet at port 23.

See [Ethernet Port Configuration](#) on page 32 for the port remapping SIS commands.

Using the Command and Response Table

The [Command and Response Table for SIS Commands](#) starting on page 25 lists valid ASCII and hexadecimal command codes, the switcher responses to the host, and a description of the command function or the results of executing the command.

The conversion table below is for use with the command and response table.

ASCII to Hex Conversion Table															
Space	20	!	21	"	22	#	23	\$	24	%	25	&	26	'	27
(28)	29	*	2A	+	2B	,	2C	-	2D	.	2E	/	2F
0	30	1	31	2	32	3	33	4	34	5	35	6	36	7	37
8	38	9	39	:	3A	;	3B	<	3C	=	3D	>	3E	?	3F
@	40	A	41	B	42	C	43	D	44	E	45	F	46	G	47
H	48	I	49	J	4A	K	4B	L	4C	M	4D	N	4E	O	4F
P	50	Q	51	R	52	S	53	T	54	U	55	V	56	W	57
X	58	Y	59	Z	5A	[5B	\	5C]	5D	^	5E	_	5F
`	60	a	61	b	62	c	63	d	64	e	65	f	66	g	67
h	68	i	69	j	6A	k	6B	l	6C	m	6D	n	6E	o	6F
p	70	q	71	r	72	s	73	t	74	u	75	v	76	w	77
x	78	y	79	z	7A	{	7B		7C	}	7D	~	7E	DEL	7F

Figure 15. ASCII to Hex Conversion Table

Unsolicited Responses

Sig[x3]•[x3]•[x3]•*[x3]←	Broadcast when signal status changes on any input or the output
Hdcp1[x12]•[x12]•[x12]←	Broadcast when HDCP status changes on any input
Hdcp0[x13]←	Broadcast when HDCP status changes on the output
In[x1]•All←	Broadcast when input selection changes via the front panel or auto-switch

Symbol Definitions

← = CR/LF (carriage return with line feed) (hex 0D 0A)

← or | = Soft carriage return (no line feed)

• = Space

[Esc] or W = Escape

NOTE: Commands are **not** case-sensitive.

For symbol definitions for specific commands, see the command listing in the [Command and Response Table for SIS Commands](#) starting on page 26.

Command and Response Table for SIS Commands

Command	ASCII Command Host to Switcher	Response Switcher to Host	Additional Description
Signal Status (corresponding to front panel LEDs)			
Input and output signal status	<code>[Esc]0LS ←</code> or <code>[Esc]LS ←</code>	<code>[X3]•[X3]•[X3]*[X3] ←</code> Sig <code>[X3]•[X3]•[X3]*[X3] ←</code>	View signal status <code>[X3]</code> of the inputs and the output. <i>Inputs * output</i>
Input HDCP status	<code>[Esc]I HDCP ←</code>	<code>[X12]•[X12]•[X12] ←</code> <i>In verbose modes 2 and 3:</i> HdcpI <code>[X12]•[X12]•[X12] ←</code>	View HDCP status <code>[X12]</code> of the inputs.
Output HDCP Status	<code>[Esc]O HDCP ←</code>	<code>[X13] ←</code> <i>In verbose modes 2 and 3:</i> HdcpO <code>[X13] ←</code>	View HDCP status <code>[X13]</code> of the output.
Input Selection			
Select all inputs	<code>[X1]!</code>	In <code>[X1]•All ←</code>	Select all inputs, video, audio, and USB.
Select an input — video and audio only	<code>[X1]%</code>	In <code>[X1]•Vid ←</code>	Select input <code>[X1]</code> , audio and video only.
View selected input — audio and video only	<code>%</code>	<code>[X1] ←</code>	View the selected input, audio and video only
Select input — USB only	<code>[X1]^</code>	In <code>[X1]•USB ←</code>	Select input <code>[X1]</code> , USB only
View selected input — USB only	<code>^</code>	<code>[X1] ←</code>	View the selected input (USB only).
Auto-switch Mode			
Set auto-switch mode	<code>[Esc][X16]AUSW ←</code>	Ausw <code>[X16] ←</code>	Set the auto-switch mode to <code>[X16]</code> .
View mode setting	<code>[Esc]AUSW ←</code>	<code>[X16] ←</code>	View the auto-switch mode.
Set user priority order for mode 1	<code>[Esc]P[X17]•[X17]•...[X17]AUSW ←</code>	AuswP <code>[X17]•[X17]•...[X17] ←</code>	Set the user-defined priority number for mode 1.
View user priority order for mode 1	<code>[Esc]PAUSW ←</code>	<code>[X17]•[X17]•...[X17] ←</code> <i>In verbose modes 2 and 3:</i> AuswP <code>[X17]•[X17]•...[X17] ←</code>	View the user-defined priority order.
View machine priority order for mode 2	<code>[Esc]O AUSW ←</code>	<code>[X17]•[X17]•...[X17] ←</code> AuswO <code>[X17]•[X17]•...[X17] ←</code>	View the priority order set by the UCS SW 313.
KEY:			
<code>[X1]</code> = Input number		0 - 3	
<code>[X3]</code> = On or off, detected or not detected		0 = Break tie	
<code>[X12]</code> = HDCP status		0 = Off or not detected	
		1 = On or detected	
<code>[X16]</code> = Auto-switch mode		0 = No source detected	
		1 = Source detected with HDCP	
		2 = Source detected without HDCP	
<code>[X17]</code> = Auto-switch priority		0 = Off or disabled (default)	
		1 = User-defined priority	
		2 = Input memory priority	
		1 = Input 1, 2 = input 2, 3 = input 3	

Command	ASCII Command Host to Switcher	Response Switcher to Host	Additional Description
Input (continued)			
Auto-switch Mode (continued)			
Set auto-switch timeout for mode 2	EscT[X18]AUSW←	AuswT[X18]↵	Set the number of seconds after which auto-switch times out.
View auto-switch timeout	EscTAUSW←	[X18]↵ AuswT[X18]↵	View the auto-switch time-out setting.
Mute Video and Audio Output			
Mute the output	[X2] B	Vmt[X2]↵	Mute the output.
Video output mute status	B	[X2]↵	View mute status [X2] for the output.
Input HDCP Authorization			
Set HDCP authorization per input	EscE[X1]*[X3]HDCP←	HdcpE[X1]*[X3]↵	Set HDCP authorization for input [X1] to [X3].
Set HDCP authorization all inputs	EscE[X3]HDCP←	HdcpE[X3]↵	Set HDCP authorization for all inputs to [X3].
HDCP authorization status	EscEHDCP←	[X3]•[X3]•[X3]↵ <i>In verbose modes 2 and 3:</i> HdcpE[X3]•[X3]•[X3]↵	View HDCP authorization status of all inputs.
Output			
Output HDCP Mode			
Set output HDCP mode	EscS[X4] HDCP←	HdcpS[X4]↵	Set HDCP authorization for the output to [X4].
Output HDCP Mode Status	EscSHDCP←	[X4]↵ HdcpS[X4]↵	View HDCP authorization status of the output.
Output Format			
Set TMDS format for the output	Esc[X5]VTPO←	Vtpo[X5]↵	Set output format [X5] for the output.
Output TMDS format status	EscVTPO←	[X5]↵	View the TMDS output format.
KEY:			
[X1] = Input number		0-3, 0 = Break tie	
[X2] = Muted or unmuted		0 = Mute off (default), 1 = Mute on, 2 = mute video and sync	
[X3] = On or off, detected or not detected		0 = Off or disabled, 1 = On or disabled	
[X4] = Output HDCP mode		0 = Off or disabled. Disables all HDCP authentication and encryption attempts. 1 = Encrypt as required by input. Continuous trials for HDMI sinks. Trials for 10 seconds on DVI sinks, then fail (default). 2 = Always encrypt. Continuous trials for HDMI sinks. Trials for 10 seconds on DVI sinks, then fail.	
[X5] = Output TMDS format		1 = Auto. HDMI RGB Full if the sink is HDMI, force DVI format if the sink is DVI (default). 2 = DVI RGB 444 Full 3 = HDMI RGB 444 Full 4 = HDMI RGB 444 Limited 5 = HDMI YUV 444 Limited 6 = HDMI YUV 422 Limited	
[X18] = Auto-switch timeout (mode 2)		0-500 seconds in 1-second intervals. Default is 3 seconds.	

Command	ASCII Command Host to Switcher	Response Switcher to Host	Additional Description
Output (continued)			
Output Color Bit Depth			
Set color bit depth for the output	<code>[Esc]V[X9]BITD←</code>	BitdV[X9]←	Set the color bit depth to [X9] for the output.
Output color bit depth Status	<code>[Esc]V BITD←</code>	[X9]←	View the color bit depth for the output.
Output 5 V Mode			
Set output 5 V mode for the output	<code>[Esc]M[X14]HPLG←</code>	Hp1gM [X14]←	Set the output 5 V mode to [X14].
View output 5 V mode	<code>[Esc]MHPLG←</code>	[X14]← <i>In verbose modes 2 and 3:</i> Hp1gM [X14]←	View the 5 V output mode setting.
HDCP Notification			
Set HDCP notification for the output	<code>[Esc]N[X3]HDCP←</code>	HdcpN[X3]←	Enable or disable HDCP notification for the output.
HDCP notification status	<code>[Esc]NHDCP←</code>	[X3]← <i>In verbose modes 2 and 3:</i> HdcpN[X3]←	View HDCP notification status [X3].
KEY:			
[X3] = HDCP notification status		0 = Off or disabled	
		1 = On or enabled	
[X9] = Output color bit depth		1 = Auto, based on sink EDID (default)	
		2 = Force 8-bit/color	
[X14] = Output 5 V mode		1 = Auto (5 V is enabled when a source with 5 V is present, disabled when 5 V source is not detected.)	
		2 = 5 V always enabled (default).	
EDID Minder			
EDID Transfer			
Import EDID (.bin) to input (store) slot	<code>[Esc]I[X6],<filename>EDID←</code>	EdidI[X6]←	Import a 128 or 256-byte binary EDID file to input slot [X6].
Export EDID (.bin) to PC	<code>[Esc]E[X6],<filename>EDID←</code>	EdidE[X6]←	Export a 128 or 256-byte binary EDID file from any position in the EDID lookup table ([X6]).
EDID Other			
View input EDID in HEX Format	<code>[Esc]R[X1]EDID←</code>	[X7]←	HEX data from EDID assigned to input [X1].
View input EDID Native Rate	<code>[Esc]N[X1]EDID←</code>	[X8]←	Native rate of EDID assigned to input [X1]
KEY:			
[X6] = EDID slot number			
[X7] = 128 or 256 byte EDID raw HEX (text form) from currently assigned EDID			
[X8] = Native resolution and refresh rate from currently assigned EDID			<i>Example: 1920x1080 @ 60 Hz.</i>

Command	ASCII Command Host to Switcher	Response Switcher to Host	Additional Description
USB Signal Status			
View input host status	<code>[Esc]I USBC ←</code>	<code>[X3]•[X3]•[X3] ←</code> <i>In verbose modes 2 and 3:</i> <code>UsbcI[X3]•[X3]•[X3] ←</code>	View signal presence <code>[X3]</code> on the two USB 3.2 type B host inputs and the USB-C input. Response format: <i>Host input 1 • host input 2 • USB-C input</i>
View USB output device status	<code>[Esc]O USBC ←</code>	<code>[X3]•[X3]•[X3]•[X3]•[X3] ←</code> <i>In verbose modes 2 and 3:</i> <code>UsbcO[X3]•[X3]•[X3]•[X3]•[X3] ←</code>	View signal presence <code>[X3]</code> on the five USB type A device ports. Response format: <i>Port1•port2•port3•port4•port5</i>
DisplayPort Alt Mode Lane Configuration			
Set USB 2.0/3.x mode	<code>[Esc]F3*[X22]USBC ←</code>	<code>UsbcF 3*[X22] ←</code>	Set operating mode <code>[X22]</code> (internal or external control) of the DisplayPort input.
View USB 2.0/3.x mode	<code>[Esc]F3 USBC ←</code>	<code>[X22] ←</code>	View the current Display port mode.
USB Device Port Status			
Enable or disable device port	<code>[Esc] X [X23]*[X3]USBC ←</code>	<code>UsbcX[X23]*[X3] ←</code>	Set state of device port <code>[X23]</code> to <code>[X3]</code> .
Enable or disable all device ports	<code>[Esc] X [X3]USBC ←</code>	<code>UsbcX[X3] ←</code>	Set state of all device ports to <code>[X3]</code> .
View all device ports status	<code>[Esc] X USBC ←</code>	<code>[X3]•[X3]•[X3]•[X3]•[X3] ←</code> <i>In verbose modes 2 and 3:</i> <code>UsbcX[X3]•[X3]•[X3]•[X3]•[X3] ←</code>	View status <code>[X3]</code> of all USB device ports.
USB 3.x Speed			
Set USB 3.x speed	<code>[Esc]S [X1]*[X38] USBC ←</code>	<code>UsbcS[X1]*[X38] ←</code>	Set the USB 3.x speed for host port <code>[X1]</code> to <code>[X38]</code> .
View all USB 3.x speed	<code>[Esc]S USBC ←</code>	<code>[X38] ←</code> <i>In verbose modes 2 and 3:</i> <code>UsbcS[X38] ←</code>	View USB 3.x speed <code>[X38]</code> for all ports.
View all USB 3.x speed per port	<code>[Esc]S [X1] USBC ←</code>	<code>[X38] ←</code> <i>In verbose modes 2 and 3:</i> <code>UsbcS[X1]*[X38] ←</code>	View USB 3.x speed <code>[X38]</code> for USB host port <code>[X1]</code> .
IP Configuration			
Set DHCP mode	<code>[Esc][X3]DH ←</code>	<code>Idh[X3] ←</code>	Set Dynamic Host Configuration Protocol (DHCP) to <code>[X3]</code> to enable or disable automatic assigning of IP addresses.
View DHCP mode	<code>[Esc]DH ←</code>	<code>[X3] ←</code>	View DHCP status <code>[X3]</code> .
KEY:			
<code>[X1]</code> = USB host port (input number)		1 - 3	
<code>[X3]</code> = On or Off setting		0 = Off or disabled (default), 1 = On or enabled	
<code>[X22]</code> = DP Alt mode setting		1 = USB 3.x + 2.0 + 4K/30 video (default), 2 = 2.0 + 4K/60 video	
<code>[X23]</code> = Device port number		0 to 5	
<code>[X38]</code> = USB 3.x port speed		10 = 10 Gbps, 5 = 5 Gbps	

Command	ASCII Command Host to Switcher	Response Switcher to Host	Additional Description
IP Configuration (continued)			
Set IP address	Esc X30 CI ←	Ipi• X30 ↵	Set unit IP address to X30 .
View IP Address	Esc CI ←	X30 ↵	View IP address X30 .
Set subnet mask	Esc X31 CS ←	Ips• X31 ↵	Set subnet mask X31 for the unit.
View subnet mask	Esc CS ←	X31 ↵	View subnet mask X31 .
Set gateway address	Esc X32 CS ←	Ips• X32 ↵	Set subnet mask X32 for the unit.
View gateway address	Esc CS ←	X32 ↵	View subnet mask X32 .
Set DNS server IP address	Esc X33 DI ←	Ipd• X33 ↵	Set DNS server address X33 for the unit.
View DNS server IP address	Esc DI ←	X33 ↵	View DNS server address X33 .
Set date and time	Esc X36 CT ←	Ipt• X36 ↵	Set local date and time, format <i>MM/DD/YY-HH:MM:SS</i> .
View date and time	Esc CT ←	X36 ↵	View local date and time, format <i>Www</i> (day of week), <i>dd</i> , <i>Mmm</i> , <i>YYYY</i> , <i>HH:MM:SS</i> .
Get connection listing	Esc CC ←	{ <i>Number of connections</i> }↵ <i>In verbose modes 2 and 3:</i> Icc { <i>Number of connections</i> }↵	View the number of devices connected to the unit.
View hardware (MAC) address	Esc CH ←	X34 ↵ <i>In verbose modes 2 and 3:</i> Iph• X34 ↵	View media access code (MAC) hardware address X34 for the unit.
KEY:			
X30 = IP address		Format <i>nnn.nnn.nnn.nnn</i> (Default is 192.168.254.254)	
X31 = Subnet mask		Format <i>nnn.nnn.nnn.nnn</i> (Default is 255.255.255.0)	
X32 = Gateway address		Format <i>nnn.nnn.nnn.nnn</i> (Default is 0.0.0.0)	
X33 = DNS server address		Format <i>nnn.nnn.nnn.nnn</i> (Default is 127.0.0.1)	
X34 = MAC address		Format <i>00-05-A6-XX-XX-XX</i>	

Command	ASCII Command Host to Switcher	Response Switcher to Host	Additional Description
IP Configuration (continued)			
CISG Commands			
NOTE: Setting any values with the CISG command changes DHCP from On to Off, and the C _{isg} response is followed by a Boot2 response (in verbose mode).			
Set IP address	<code>[Esc] X37*X30CISG ←</code>	<code>Cisg•X37*X30/X35 ←</code>	Set the product IP address to <code>X30</code> and the subnet mask prefix to <code>X35</code> on network server <code>X37</code> .
Set IP address and subnet mask	<code>[Esc] X37*X30*X35CISG ←</code>	<code>Cisg•X37*X30/X35*X30 ←</code>	Set the product IP address to <code>X30</code> , and the subnet mask prefix to <code>X35</code> .
Set IP, subnet, and gateway addresses	<code>[Esc] X37*X30/X35*X30CISG ←</code>	<code>Cisg•X37*X30/X35*X30 ←</code>	Set the IP address to <code>X30</code> , the subnet mask prefix to <code>X35</code> , and gateway address to <code>X32</code> at one time.
View IP, subnet, and gateway addresses	<code>[Esc]X37CISG ←</code>	<code>X30/X35*X30 ←</code> <i>In verbose modes 2 and 3:</i> <code>Cisg•X30/X35*X30 ←</code>	View IP address, subnet mask prefix, and gateway address at one time.
KEY:			
<code>X30</code> = IP address		Format <i>nnn.nnn.nnn.nnn</i> (Default is 192.168.254.254)	
<code>X32</code> = Gateway address		Format <i>nnn.nnn.nnn.nnn</i> (Default is 0.0.0.0)	
<code>X33</code> = DNS server address		Format <i>nnn.nnn.nnn.nnn</i> (Default is 127.0.0.1)	
<code>X34</code> = MAC address		Format <i>00-05-A6-XX-XX-XX</i>	
<code>X35</code> = Subnet mask prefix (CISG commands)		Subnet mask prefix (subnet mask bits). In CISG commands, the default subnet mask 255.255.255.0 is represented as prefix value /24.	
<code>X36</code> = Date and time		Set format: <i>MM/DD/YY-HH:MM:SS</i> Example: 08/17/21-13:51:30 View format: <i>Day of week, day•month•year•hour:minutes:seconds (Www,DD•Mmm•YYYY•HH:MM:SS)</i> Example: Fri, 21 Jun 2002 10:54:00	
<code>X37</code> = Network interface card (NIC) number		1-3 (If the NIC number is not applicable to the UCS SW 313, an E13 error message is returned.)	
Front Panel Lock Mode			
Set front panel lock mode	<code>X21X</code>	<code>ExeX21 ←</code>	Enable or disable front panel lockout (executive mode).
View front panel lock mode	X	<code>X21 ←</code>	View front panel lock status <code>X21</code> .
Power Save Mode			
Set power save mode	<code>[Esc]X3PSAV ←</code>	<code>PsavX3 ←</code>	Enable or disable power save.
View power save mode status	<code>[Esc]PSAV ←</code>	<code>X3 ←</code>	View power save mode On or Off status.
KEY:			
<code>X3</code> = Power save mode setting		0 = Off or disabled (default), 1 = On or enabled	
<code>X21</code> = Front panel lock (executive) mode		0 = Off or disabled (default), 1 = Front panel lockout	

Command	ASCII Command Host to Switcher	Response Switcher to Host	Additional Description
---------	-----------------------------------	------------------------------	------------------------

IP Configuration (continued)

Verbose Mode

Set verbose mode	<code>Esc X10 CV ←</code>	<code>Vrb X10 ↵</code>	
View verbose mode status	<code>Esc CV ←</code>	<code>X10 ↵</code>	View current verbose mode <code>X10</code> .

NOTES:

- In **verbose response** mode, the switcher responds with unsolicited responses for value and setting changes that may result from a signal change, or a setting adjustment made via another interface.
For example, the switcher can send out a notice of a change in some setting without receiving a query via a PC or a control system. That change could have been a result of an internal process, a selection made from the front panel, or a selection made via PCS. This is an example of a verbose relationship between the controller and a connected device.
- If **tagged responses** are enabled, all View type commands return the command string plus the data, the same as in responses for setting a value. For example:
Command: `Esc CN ←` (View unit name)
Response: `Ipn • X11 ↵` (tagged response) or `X11 ↵` (untagged response)

	Verbose Responses	Tagged Responses
<code>X10 Value</code>	Receive unsolicited responses (messages) for all actions initiated via any source (touchpanel, port input, internal web page changes, or commands) instead of only for SIS ommands.	Receive tagged responses to read or view commands. (Responses to SIS commands are always tagged. Turning tagged responses on adds tags to the responses to SIS read requests.)
0		
1	✓	
2		✓
3	✓	✓

Unit Name

Set unit name	<code>Esc X11 CN ←</code>	<code>Ipn • X11 ↵</code>	Assign name <code>X11</code> for the unit.
Set unit name to default	<code>Esc • CN ←</code>	<code>Ipn • X15 ↵</code>	Set the UCS SW 313 device name to default <code>X15</code> .
View unit name	<code>Esc CN ←</code>	<code>X11 ↵</code>	

NOTES:

- Changes made to any TCP/IP settings do not take effect until the reboot network command (`Esc 2B00T ←`) is issued.
- IP address setup commands that are followed by ²⁴ require Administrator permission to enter. Attempts to issue them without Administrator status result in an E24 (privilege violation) error message.

KEY:

<code>X10</code> = Verbose mode	0 = None (default for IP connection) 1 = Verbose mode 2 = Tagged responses for queries 3 = Verbose mode and tagged responses for queries
<code>X11</code> = Unit name	Text string of up to 24 characters. Permitted characters include letters (A-Z), digits (0-9), and the hyphen or minus sign (-). Blank and space characters are not allowed. The first character must be a letter, and the last character cannot be a hyphen.
<code>X15</code> = Default unit name	Model name followed by the last three character pairs of the MAC address. <i>Example:</i> UCS-313-00-02-3D
<code>X21</code> = Front panel lock (executive) mode	0 = Off or disabled (default), 1 = Front panel lockout

Command	ASCII Command Host to Switcher	Response Switcher to Host	Additional Description
IP Configuration (continued)			
Ethernet Port Configuration			
Set web port map	<code>[Esc]W {port number}PMAP←</code>	<code>Pmap W{port number}↵</code>	Set the web port number.
Reset web port map	<code>[Esc]W 80 PMAP←</code>	<code>Pmap W 00080↵</code>	Set the web port number to 80 (default).
Disable web port	<code>[Esc]W 0 PMAP←</code>	<code>Pmap W 00000↵</code>	Disable the web port.
View web port mapping	<code>[Esc]W PMAP←</code>	<code>{port number}↵</code>	View the currently set web port.
Set Telnet port map	<code>[Esc]Z {port number}PMAP←</code>	<code>Pmap Z{port number}↵</code>	Set the Telnet port number.
NOTE: Telnet port 23 is disabled by default.			
Reset Telnet port map	<code>[Esc]Z 23 PMAP←</code>	<code>Pmap Z 00023↵</code>	Set the Telnet port number to 23 (default).
Disable Telnet port	<code>[Esc]Z 0 PMAP←</code>	<code>Pmap Z 00000↵</code>	Disable the Telnet port.
View Telnet port mapping	<code>[Esc]Z PMAP←</code>	<code>{port number}↵</code>	View the current Telnet port.
SIS-over-SSH			
NOTES:			
<ul style="list-style-type: none"> The echo setting must match the type of SSH client used. With echo enabled (default), characters that are typed into the client window are echoed in the window along with the SIS response, and are also sent to the server. With echo disabled, the characters are not echoed but are simply sent to the server. The echo setting applies only to current (not global) connection. Control systems should turn echo off after connecting. 			
Enable echo (default)	<code>[Esc]1ECHO←</code>	<code>Echo 1↵</code>	Echo on: All data sent is echoed back to the sender, followed by the response. Extra carriage returns may also be received when echo is on.
Disable echo	<code>[Esc]0ECHO←</code>	<code>Echo 0↵</code>	Echo off: only the response is sent to the sender.
View echo status	<code>[Esc]ECHO←</code>	<code>[X3]↵</code>	View the echo setting.
Set SIS-over-SSH port map	<code>[Esc]B[X37]*{port number} PMAP←</code>	<code>PmapB•[X37]*{port number}↵</code>	Set the SIS-over-SSH port.
Reset SIS-over-SSH port map	<code>[Esc]B[X37]*22023 PMAP←</code>	<code>PmapB•[X37]*22023↵</code>	Reset the SSH port to the default 22023.
Disable SIS-over-SSH port	<code>[Esc]B[X37]*0 PMAP←</code>	<code>PmapB•[X37]*00000↵</code>	Disable the SIS-over-SSH port.
View the SIS-over-SSH port mapping	<code>[Esc]B[X37] PMAP←</code>	<code>{port number}↵</code>	View the current SIS-over-SSH port mapping.
KEY:			
<code>[X3]</code> = Echo status		0 = Off or disabled, 1 = On or enabled (default)	
<code>[X37]</code> = Network interface card (NIC) number		1-2	

Command	ASCII Command Host to Switcher	Response Switcher to Host	Additional Description
IP Configuration (continued)			
Passwords			
NOTE: The initial passwords set at the factory are the serial number of the unit. However, if the unit is reset (via the ZQQQ SIS command or the front panel Reset button), this password reverts to extron.			
Set administrator password	<code>[Esc]X27CA←</code>	<code>Ipa•X27↵</code>	Set the administrator password to <code>X27</code> .
View administrator password	<code>[Esc]CA←</code>	<code>****↵</code> or <code>↵</code> <i>In verbose modes 2 and 3:</i> <code>Ipa•****↵</code> or <code>Ipa↵</code>	View the administrator password.
Reset (clear) administrator password	<code>[Esc]•CA←</code>	<code>Ipa•↵</code>	Reset or clear the administrator password.
Set user password	<code>[Esc]X27CA←</code>	<code>Ipu•X27↵</code>	Set the user password.
View user password	<code>[Esc]CA←</code>	<code>****↵</code> or <code>↵</code> <i>In verbose modes 2 and 3:</i> <code>Ipu•****↵</code> or <code>Ipu↵</code>	View the user password. If there is a valid password, the response is <code>****↵</code> . If there is no password, the response is <code>↵</code> .
Reset (clear) user password	<code>[Esc]•CA←</code>	<code>Ipu•↵</code>	Reset or clear the user password.
KEY:			
<code>X27</code> = Password		<ul style="list-style-type: none"> Length is 1-128 characters. All human-readable characters are permitted except . The password cannot be a single space. Passwords are case-sensitive. A user password cannot be assigned if no administrative password exists. An E14 error code is returned. If the admin password is cleared, the user password is cleared also. 	
NOTE: If there is a valid password, the response is <code>****↵</code> . If there is no password, the response is <code>↵</code> .			
Contact/Tally Port Status			
Contact Port Status			
View individual contact port status	<code>[Esc]X28CNTC←</code>	<code>X29↵</code>	View the contact status <code>X29</code> of contact port <code>X28</code> .
View status of all contact ports	<code>[Esc]CNTC←</code>	<code>X29•...X29↵</code>	View status <code>X29</code> of all ports.
Tally Port Status			
Set individual port state	<code>[Esc]X28*X29TALY←</code>	<code>TalyX28*X29↵</code>	Set the tally output state for port <code>X28</code> to <code>X29</code> .
Set states of all ports	<code>[Esc]X29...X29TALY←</code>	<code>TalyX29...X29↵</code>	Set all tally ports at once to port state <code>X29</code> .
View individual tally port status	<code>[Esc]X28TALY←</code>	<code>X29↵</code>	View the tally status <code>X29</code> of tally port <code>X28</code> .
View status of all tally ports	<code>[Esc]TALY←</code>	<code>X29•...X29↵</code>	View status <code>X29</code> of all tally ports.
KEY:			
<code>X28</code> = Contact/Tally port number		1 through 5	
<code>X29</code> = Contact/Tally port state		0 = Open, 1 = Closed	

Command	ASCII Command Host to Switcher	Response Switcher to Host	Additional Description
Information Requests			
Information	I	In $\overline{x1}$ •Afmt $\overline{x19}$ •Ausw $\overline{x16}$ ↵	View input number $\overline{x1}$, input audio format $\overline{x19}$, and auto-switch mode $\overline{x16}$ for the selected input.
Query part number	N	$\overline{x20}$ ↵ <i>In verbose modes 2 and 3:</i> Pno• $\overline{x20}$ ↵	View the UCS SW 313 unit part number.
Query model name	1I	UCS-313↵ <i>In verbose modes 2 and 3:</i> Inf01*UCS-313↵	View the UCS SW 313 model name.
Query firmware version	Q	$\overline{x24}$ ↵	View current firmware version $\overline{x24}$.
Query firmware version with build	*Q	$\overline{x25}$ ↵	Show full firmware version $\overline{x25}$.
Query detailed firmware versions	0Q	$\overline{x26}$ ↵	Show the full firmware version plus build number and any special text ($\overline{x26}$).

NOTE: For $\overline{x24}$, the following symbols may appear after the version number (see the example below):

- * = The firmware version is the current or active version.
- ?. ?? = Only the factory firmware version is loaded. This replaces the updated firmware version.
- ^ = The default factory firmware version is loaded instead of the listed version due to a firmware reset to factory defaults.
- ! = The current firmware version is corrupted.

Example response:

Cmd.	Version number	Kernel version	Upload date and time	Indicator	Model description
001.00-1.00.0000-b115	(2.07LX-UCS 313	-Fri, 19 Jul 2024 15.42 UTC)	-1.00.0000-b004*	(2.07LX-UCS 313	-Tue, 03 Aug 2023 17:56 UTC)↵
Boot loader version	Factory base firmware version		Updated firmware version		

KEY:

- | | |
|---|---|
| $\overline{x1}$ = Input number | Number of the currently selected input. |
| $\overline{x16}$ = Auto-switch timeout (mode 2) | 0-500 seconds in 1-second intervals. Default is 3 seconds. |
| $\overline{x19}$ = Input audio format | 0 = None (muted), 1 = Digital (default) |
| $\overline{x20}$ = Unit part number | 60-1797-01 |
| $\overline{x24}$ = Firmware boot loader version | Shown to second decimal place (<i>n.nn</i>) |
| $\overline{x25}$ = Full firmware version | <i>n.nn.nnnn</i> |
| $\overline{x26}$ = Full firmware version — advanced | Full firmware version with build and any special text (<i>n.nn.nnnn-bnnn</i>) |

Command	ASCII Command Host to Switcher	Response Switcher to Host	Additional Description
Resets			
Reset to factory defaults	Esc ZXXX ←	Zpx↵	Reset the switcher to factory default values.
Reset all IP settings	Esc 1ZQQQ ←	Zpq1↵	Reset only IP settings to factory values.
NOTE: This command includes the 2BOOT ← command (reboot the system and discard network settings) so a separate 2BOOT ← command is not required. The Zpq1↵ response is followed by Reconfig↵ and Boot2↵ responses.			
Reset all settings except IP settings	Esc ZY ←	Zpy↵	Reset all device settings to factory defaults except IP settings (communication is preserved). This command is recommended for after a firmware update.
Absolute system reset	Esc ZQQQ ←	Zpq↵	Reset all device settings to factory defaults except the firmware version.
NOTE: Entering this command or performing an absolute system reset via the front panel Reset button (see Resetting on page 16) changes the current passwords (whether user-set or the factory-set serial number) to extron.			

Symbol Definitions for CEC Communications Commands

- X40** = CEC mode
 0 = Disable CEC operations for this IO port (default)
 2 = Enable insertion (unidirectional)
 4 = Enable insertion and publish received CEC messages (bidirectional) (recommended mode)
- X41** = CEC status
 0 = CEC mode 0 disabled
 2 = CEC mode 2 enabled but no device detected (unidirectional)
 3 = CEC mode 2 enabled and device detected (unidirectional)
 4 = CEC mode 4 enabled but no device detected (bidirectional)
 5 = CEC mode 4 enabled and device detected (bidirectional)
- X42** = Source logical address (our pseudo): 0 through 15 (-1 = not found or port not enabled)
- X43** = Destination logical address (theirs): 0 through 15 (-1 = not found or port not enabled)

CEC Logical Addresses	
Address	Device
0	TV
1	Recording Device 1
2	Recording Device 2
3	Tuner 1
4	Playback Device 1
5	Audio System
6	Tuner 2
7	Tuner 3
8	Playback Device 2
9	Recording Device 3
10	Tuner 4
11	Playback Device 3
12	Reserved
13	Reserved
14	Free Use
15	Unregistered (as initiator address) Broadcast (as destination address)

- X44** = CEC command: Predefined actions as strings within double quotes: “PwrOn”, “PwrOff”, or “ShowMe”
- X45** = Send result
 0 = Failed (NAK)
 1 = Success (ACK) of entire message
 2 = Unable to send
- X46** = CEC physical address: four hexadecimal digits
 Example: %10%00 for 1000
- X48** = CEC data: User selected elements (0 to 15) in the form of percent sign followed by two hex digits
 (Example: %2A%07%FF)
- X49** = CEC address byte: In the form of percent sign followed by two hex digits
 Example: %E0 = Extron output (14) to TV (0)

NOTE: Unless otherwise indicated, commands are not case-sensitive.

Command and Response Table for CEC Communications SIS Commands

Command	ASCII Command (Host to Switcher)	Response (Switcher to Host)	Additional Description
CEC Enable/Disable			
Enable or disable the output CEC	<code>[Esc]01*[X40]CCEC←</code>	<code>Ccec01*[X40]←</code>	
View output CEC status	<code>[Esc]01CCEC←</code> Verbose mode 2/3	<code>[X41]*[X42]*[X43]←</code> <code>Ccec01*[X41]*[X42]*[X43]←</code>	
Send CEC Commands			
Default Discovered Target Logical Address			
Send CEC data to Output (downstream sink)	<code>[Esc]01*[X44]DCEC←</code> or <code>[Esc]01*[X43]DCEC←</code>	<code>Dcec01*[X49][X44]*[X45]←</code>	The response is always in a hex representation (<code>[X48]</code>), for example: <code>%2A%07%FF</code> .
Broadcast to All Devices			
Send CEC data to Output (downstream sink)	<code>[Esc]01*15*[X44]DCEC←</code> or <code>[Esc]01*15*[X48]DCEC←</code>	<code>Dcec01*[X49][X48]*[X45]←</code>	
NOTE: Attempting to send a CEC command to an input or output that is disabled returns an E14 error.			
KEY:			
<code>[X40]</code> = CEC mode		0 = Disable CEC operation for this IO port (default) 2 = Enable insertion and break CEC connection input to output (unidirectional) 4 = Enable insertion and publish received CEC messages (bidirectional)	
<code>[X41]</code> = CEC status		0 = CEC mode 0 disabled 2 = CEC mode 2 enabled but no device detected (unidirectional) 3 = CEC mode 2 enabled and device detected (unidirectional) 4 = CEC mode 4 enabled but no device detected (bidirectional) 5 = CEC mode 4 enabled and device detected (bidirectional)	
<code>[X42]</code> = Source logical address (our pseudo)		0 through 15 (-1 = not found or port not enabled) s = Destination logical address (theirs): 0 through 15 (-1 = not found or port not enabled) (See CEC Logical Addresses on page 36.)	
<code>[X44]</code> = CEC command		Predefined actions as strings within double quotes: "PwrOn", "PwrOff", or "ShowMe".	
<code>[X45]</code> = Send result		0 = Failed (NAK) device not detected, 1 = Success (ACK) device detected, 2 = Unable to send	
<code>[X48]</code> = CEC data		User selected elements (0 to 15) in the form of percent sign followed by two hex digits (Example: <code>%2A%07%FF</code>)	
<code>[X49]</code> = CEC address byte		In the form of a percent sign (%) followed by two hex digits <i>Example:</i> <code>%E0</code> = Extron output (14) to TV (0)	

Command	ASCII Command (Host to Switcher)	Response (Switcher to Host)	Additional Description
CEC Usage Examples			
Unidirectional Mode — No CEC received data messages (including answers to queries) desired			
Set mode	<code>[Esc]00*2CCEC←</code>	<code>Ccec00*2←</code>	Power on TV on output 1.
Send data	<code>[Esc]00*"PwrOn"DCEC←</code> or <code>[Esc]00*%04DCEC←</code>	<code>Dcec00*%E0%04*1←</code>	
Bidirectional Mode — CEC received data messages desired			
Set mode	<code>[Esc]00*4CCEC←</code>	<code>Ccec00*4←</code>	Switch TV on output 1 to our signal (HDMI 2 on TV).
Send data	<code>[Esc]00*"ShowMe"DCEC←</code> or <code>[Esc]00*15*%82%20%00DCEC←</code>	<code>Dcec00*%EF%82%20%00*1←</code>	
Examples of possible unsolicited messages		<code>Ceco0*%0F%32%65%6E%67*1←</code> <code>Ceco0*%0E*1←</code>	TV broadcast command to set the menu language to English ("eng"). TV pings us to confirm we are still there.
NOTE: Asynchronous received data messages from CEC in bidirectional mode (4) format:			<code>Ceci[X1]*[X49][X46]*[X45]←</code> <code>Ceco1*[X49][X46]*[X45]←</code>
Other CEC Commands			
Rediscover device on output	<code>[Esc]01QCEC←</code>	<code>Qcec01*1←</code> <code>Qcec01*0*[X45]←</code> ... <code>Qcec01*13*[X45]←</code>	
Report physical address of output port	<code>[Esc]01PCEC←</code> Verbose mode 2/3 <i>Example</i>	<code>[X46]←</code> <code>Pcec01*[X46]←</code> <code>%10%00</code>	For 1000 (usually first HDMI input on TV).
KEY:			
<code>[X1]</code>	= Input number	1 to 3	
<code>[X45]</code>	= Send result	0 = Failed (NAK) device not detected 1 = Success (ACK) devices detected 2 = Unable to send	
<code>[X46]</code>	= CEC physical address	Four hexadecimal digits in the form of %xx%xx (<i>Example:</i> %32%00)	
<code>[X49]</code>	= CEC address byte	In the form of percent sign followed by two hex digits <i>Example:</i> %E0 = Extron output (14) to TV (0)	

Product Configuration Software

The Extron Product Configuration Software (PCS) offers another way to configure the UCS SW 313 Collaboration switchers via a USB-C connector in addition to the SIS commands. This section describes software installation and communication, along with updating firmware. Topics in this section include:

- [Downloading PCS from the Website](#)
- [Starting PCS](#)
- [Updating Firmware](#)
- [Firmware Loader](#)

The Extron PCS software program is a Windows-based program for the UCS that provides a convenient way to configure the input and output, audio, and image settings. It lets you perform nearly all the other functions that can be accomplished via the front panel controls or SIS commands.

Downloading PCS from the Website

To use the Product Configuration Software, download the latest version of the program from the [Extron web page](#) and install it on the PC connected to the UCS, as described in the following sections. You can also download updates to the UCS software as they become available.

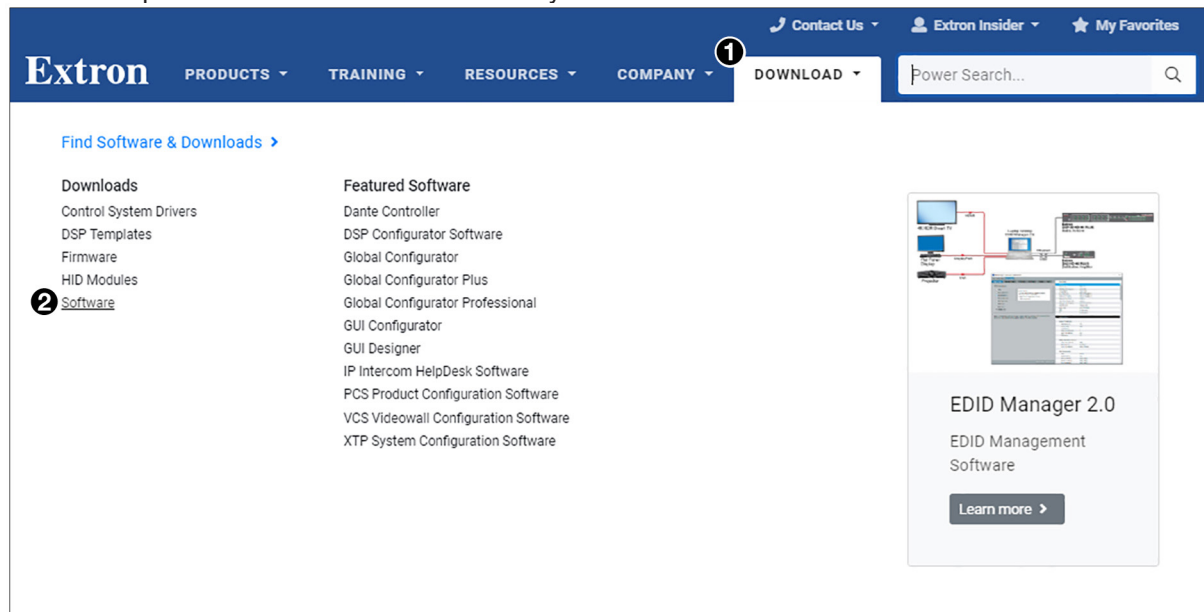

Figure 16. Download Center Page on the Extron Website

To access the software:

1. On the Extron website, hover the pointer over the **DownLoad** tab (see figure 16, ❶).
2. Click the **Software** link (❷) in the DownLoads column.

- On the Download Center screen, click on the down arrow in the **Search Software** box to see a list of the downloadable software (see figure 17, ❶). If you need an Extron Insider ID number to access this box, see your Extron representative.

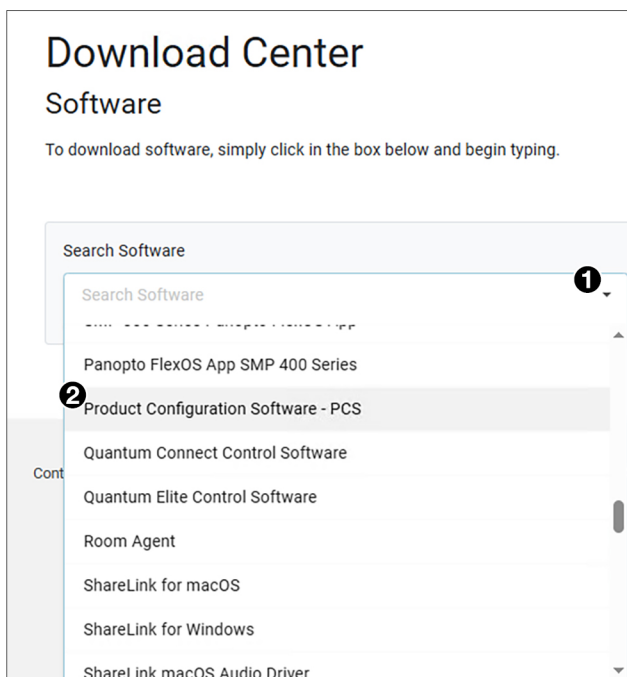

Figure 17. PCS Links on Software Download Center Screen

- From the drop-down list, select Product Configuration Software - PCS (❷).
- On the Product Configuration Software - PCS Download Center screen, click the link to the active PCS version (see figure 18, ❶). After a few seconds, a link to the VCS installer on your PC appears.

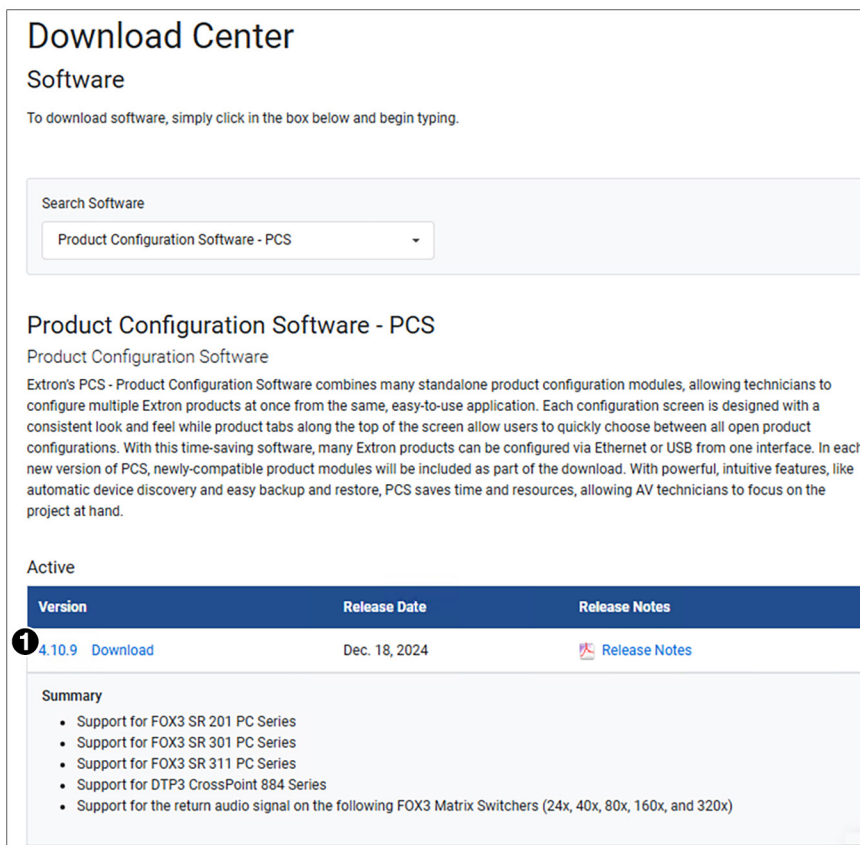

Figure 18. PCS Download Center Screen

6. Click the link to locate the installer file, then follow the instructions on the screen to complete the PCS installation.
7. On the login page that appears next, fill in the required information to log in to www.extron.com (if you need an Extron Insider ID number, see your Extron representative).
8. Follow the instructions on the subsequent screens to complete the software program installation. By default, the configuration program files are stored on your computer at:
C:\Program Files (x86)\Extron\Extron PCS.
If there is not already an Extron folder in your Program Files (x86) folder, the installation program creates it.

Starting PCS

In order to use the PCS software, the UCS must be connected to your computer via the front panel USB-C port or the rear panel LAN port.

1. To start the configuration program, do either of the following:
 - From the desktop Start menu, select **Extron/Extron Product Configuration Software**.
The Extron Product Configuration Software window opens.
 - Double-click on the EAF.exe file, located on your computer at
c:\Program Files(x86)]\Extron\Extron PCS.
2. In the Device Discovery panel of the PCS window, click on the name of your UCS SW 313 (see figure 19, ①). (You may need to scroll to locate it, depending on the number of devices listed.) The **Connect** button (②) becomes available.

NOTE: If the UCS is connected via the LAN port (UCS SW 313 only), its IP address is displayed in the IP Address column. If it has a USB connection, the generic address for devices connected via IP over USB (203.0.113.22) is displayed.

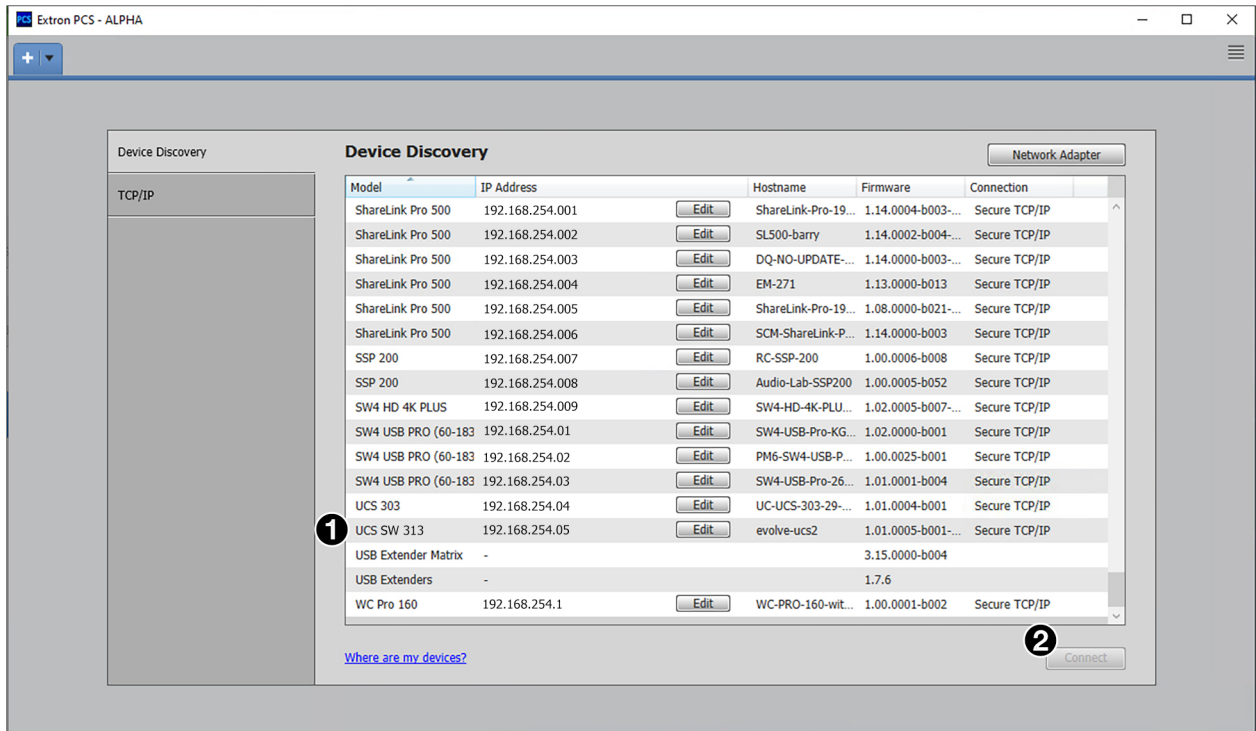

Figure 19. Device Discovery Panel on PCS Connection Screen

- Click **Connect** (see [figure 19](#), [2](#) on page 41), or double-click on the UCS name in the Device Discovery list. If the unit has a password defined, the following prompt opens:

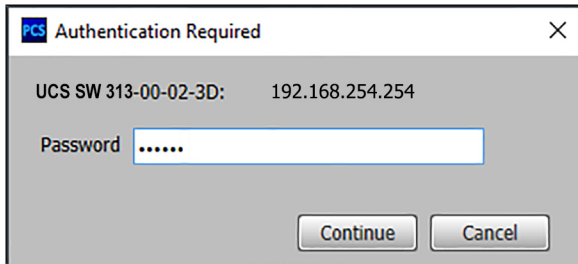

Figure 20. Password Prompt

- Enter the password for the unit and click **Continue**.

NOTE: The factory configured passwords for all accounts on this device have been set to the device serial number. Passwords are case sensitive. In the event of an absolute system reset, the passwords are set to extron.

- If this is the first time you have opened the current version of PCS, the Tutorial screen appears, identifying items on the toolbar at the top of the PCS screen. When finished viewing the tutorial, click **OK** to close the screen. The Extron PCS device configuration window opens.

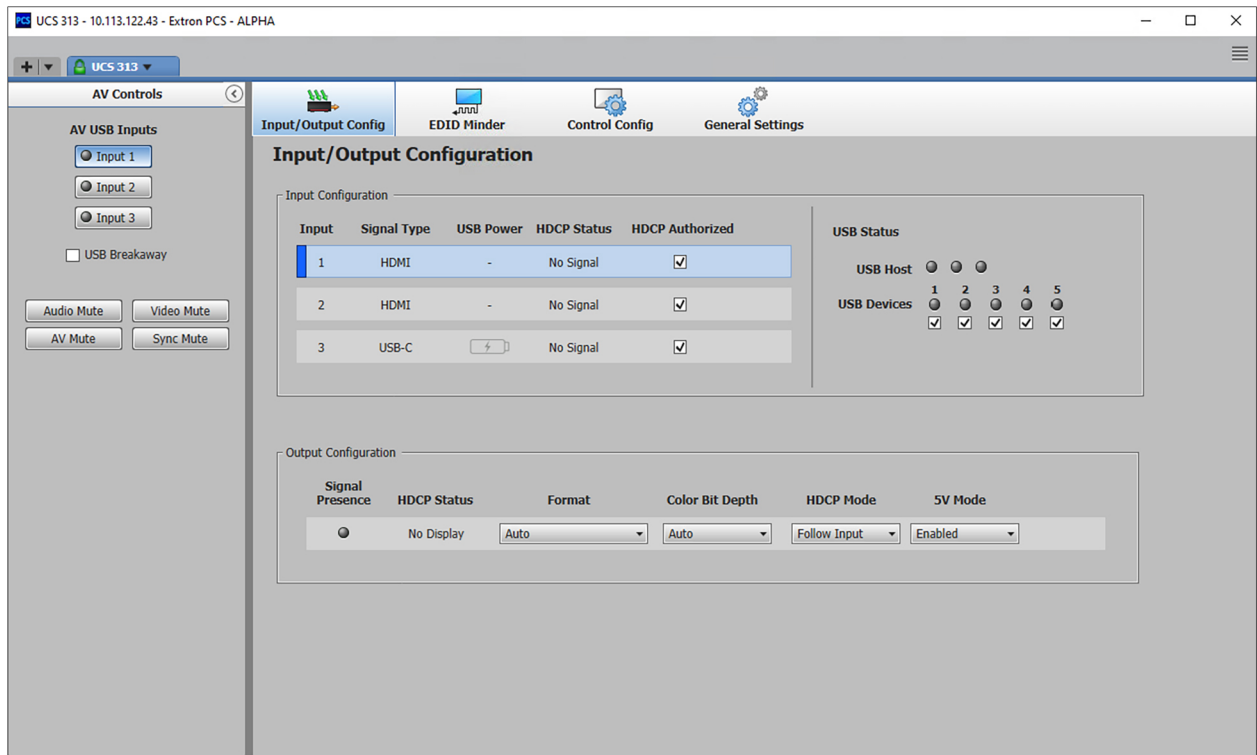

Figure 21. UCS SW 313 Device Configuration Window

Connecting Using the TCP/IP Panel

The TCP/IP panel connects PCS to a specific device through Ethernet. To access this panel, click the **TCP/IP** tab to the left of the Device Discovery panel (see figure 22, ①).

The screenshot shows the 'TCP/IP' panel within a 'Device Discovery' window. On the left, a sidebar contains a 'TCP/IP' tab, which is highlighted with a circled '1'. The main area is titled 'TCP/IP' and contains two configuration sections. The first section, 'Target Device', is highlighted with a circled '2' and includes fields for 'IP Address/Hostname' (192.168.254.254), 'Password' (masked with dots), and 'Port' (blank), along with a 'Show Characters' checkbox. Below this, a checkbox for 'Enable Indirect Connection' is checked and highlighted with a circled '3'. The second section, 'IP Link Pro Control Processor with AV LAN', is highlighted with a circled '4' and includes fields for 'IP Address/Hostname' (192.168.254.1) and 'Password' (masked with dots), along with a 'Show Characters' checkbox. At the bottom right, a 'Connect' button is highlighted with a circled '5'.

Figure 22. TCP/IP Panel

To connect directly to a connected device with a known IP address:

1. In the **IP Address/Hostname** field of the Target Device panel (②), enter the IP address of the desired device.
2. Enter the device password in the **Password** field.

NOTES:

- The factory configured passwords for all accounts on this device have been set to the device serial number. Passwords are case sensitive. In the event of an absolute system reset, the administrator passwords are set to extron and the user passwords are set to no password (blank).
- If desired, select the **Show Characters** checkbox (below the **Port** field) to display the password characters.

3. In the **Port** field of the Target Device panel (②), enter the port number of the desired device (the default port is 4523).

NOTE: If the TCP/IP port number is not known, leave this field blank. PCS scans for the port and fills it in.

4. Click the **Connect** button (⑤). A new device tab opens.

To connect indirectly to a device through a control processor via an AV LAN:

If your UCS SW 313 is connected to an AV LAN, you can connect to it through a control processor such as an Extron IPCP, as follows:

1. In the **IP Address/Hostname** field of the Target Device panel (②), enter the IP address of the UCS SW 313 on the AV LAN, as well as the port number (the default is 4523) and the password.
2. Select the **Enable Indirect Connection** checkbox (③).
3. In the **IP Address/Hostname** field of the IP Link Control Processor with AV LAN panel (④), enter the IP address of the control processor connected to the AV LAN.

4. Enter the password.
5. Click **Connect** (see [figure 22](#), **5** on page 43). The TCP/IP window closes and the UCS device configuration window opens.

See the *UCS SW 313 and UCS 303 Help File*, included with PCS, for instructions on using this software to configure the UCS.

Updating Firmware

Extron periodically updates product firmware. Before updating any Extron product to the latest revision level, be sure to read the supplied release notes or contact Extron Technical Support to determine if your product requires a firmware update.

You can update firmware using PCS (see the *UCS SW 313 and UCS 303 Help File*) the UCS SW 313 web page (see [Firmware Panel](#) on page 55), or Toolbelt (see the *Toolbelt Help File*).

Firmware Loader

The Firmware Loader program enables you to upload new versions of firmware to your UCS SW 313. The program also provides a means of uploading firmware files to multiple devices simultaneously. When you are notified that new firmware is available for your switcher, download the firmware file from the Extron website and install it on your computer (see [Downloading Firmware Loader](#) on page 44). You can then upload the new version of firmware to the switcher.

Before updating any Extron product to the latest revision level, be sure to read the supplied release notes or contact Extron Technical Support to determine if your product requires a firmware update.

Downloading Firmware Loader

To obtain Firmware Loader from the Extron website:

1. On the Extron website, select the **Download** tab (see [figure 23](#), **1**).

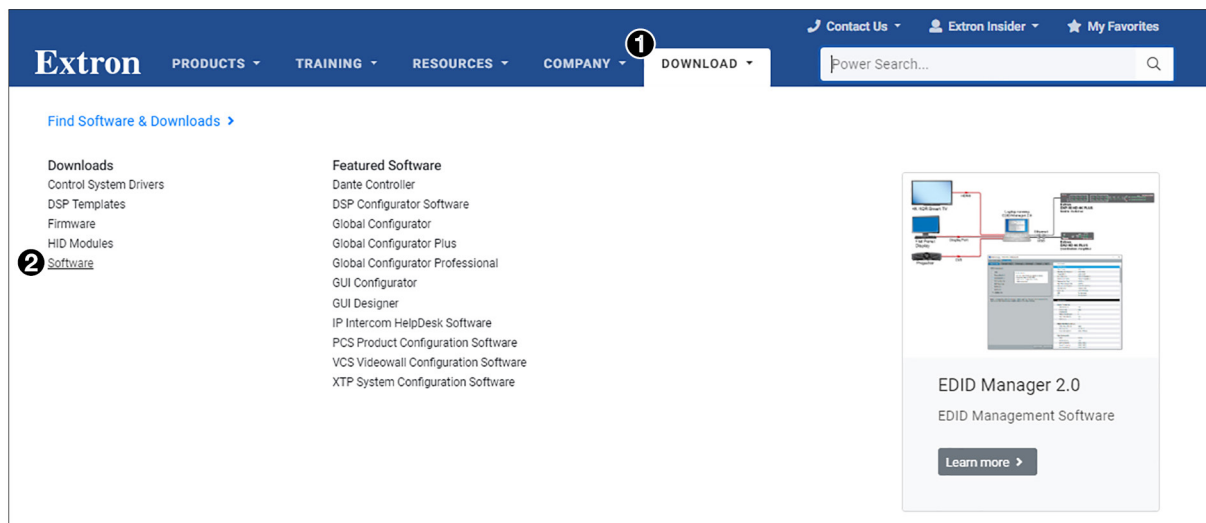

Figure 23. Software Link on the Download Page

2. Click the **Software** link (**2**) in the Downloads column.

3. On the Software Download Center screen, click on the down arrow (see figure 24, ❶) in the **Search Software** box and select **Firmware Loader** from the drop-down list. If you need an Extron Insider ID number to access this box, see your Extron representative.

Download Center
Software

To download software, simply click in the box below and begin typing.

Search Software
Firmware Loader ❶

Firmware Loader
Free Firmware Upgrade Utility

Extron Firmware Loader is a free Windows compatible software utility that allows one or more Extron products with field-upgradable firmware to be updated simultaneously. The utility supports firmware updates to Extron products connected via USB, RS-232, or Ethernet. Powerful features such as a product dropdown list, multiple communication methods, and simultaneous multi-device upload provide greater flexibility for more elaborate control systems.

Active

Version	Release Date	Release Notes
❷ 5.3.0 Download	Mar. 20, 2018	Release Notes

Summary
New in the Current Release

- o Ability to load firmware to devices that have sub-devices
- o Various bug fixes

Figure 24. Firmware Loader Download Center Page

4. Click the link to the active Firmware Loader version (❷). After a few seconds, a link to the firmware installer file in your Downloads folder appears.

NOTE: When downloaded from the Extron website, by default the Firmware Loader files are placed at C:\Program Files (x86)\Extron\FWLoader.

5. Click the link to the installer file, then follow the instructions on the screens to install the Firmware Loader.

Updating Firmware Using Firmware Loader

To use Firmware Loader to upload a new firmware file to your unit:

1. Open the Firmware Loader via your desktop Start menu. The Firmware Loader window opens with the Add Device dialog box displayed in front of it.
2. From the Device Name drop-down list (see figure 25, ①), select **UCS SW 313**.
3. Click **Connect** (②). If the connection is successful, UCS SW 313 ✓ is displayed in green in the Connected Device panel (③).

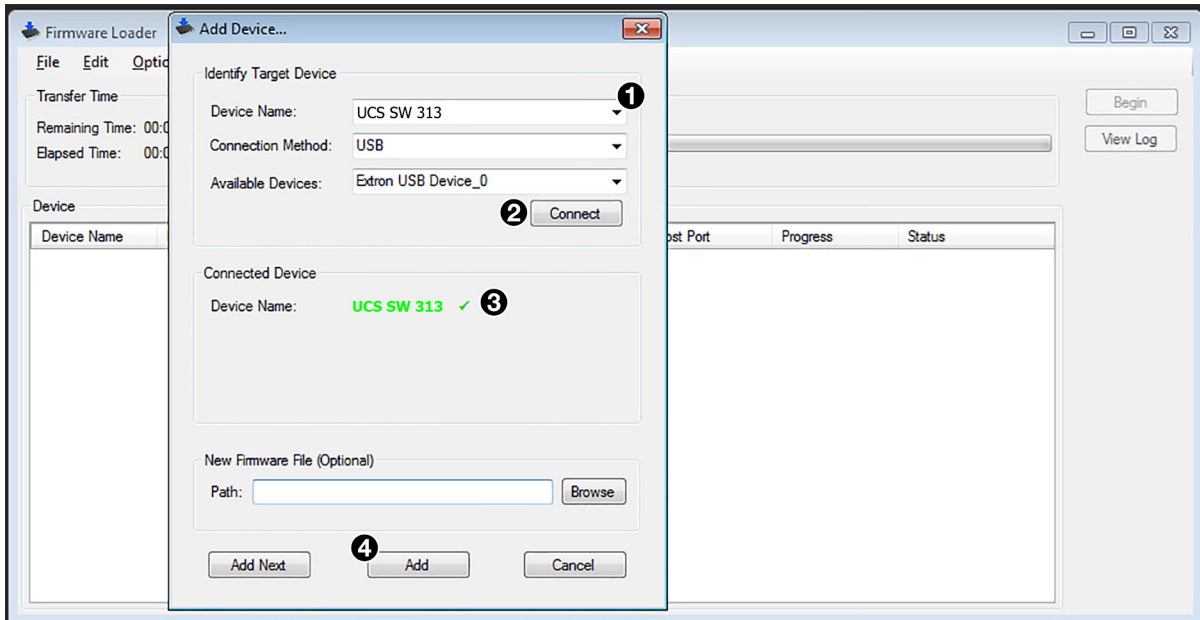

Figure 25. Successful Connection to the Switcher via Firmware Loader

4. Click **Add** (④) at the bottom of the dialog box. The Add Device window closes, and the UCS SW 313 information is added to the Device panel of the Firmware Loader dialog box.
5. Double click on <double click to set> in the New Firmware File column.
6. In the Choose Firmware File window, browse to locate the new firmware file, select it (see figure 26, ① on page 47) and click **Open** (②).

ATTENTION:

- Valid firmware files must have the file extension .eff. A file with any other extension is not a firmware upgrade for this product and could cause the device to stop functioning.
- Les fichiers firmware valides doivent contenir l'extension fichier .eff. Un fichier avec n'importe quelle autre extension n'est pas une mise à jour de firmware pour cet appareil et l'appareil pourrait arrêter de fonctionner.

NOTES:

- When downloaded from the Extron website, by default the firmware is placed at C:\Program Files (x86)\Extron\Firmware\UCS SW 313.
- To get the part number for your unit, see [Query part number](#) on page 34.

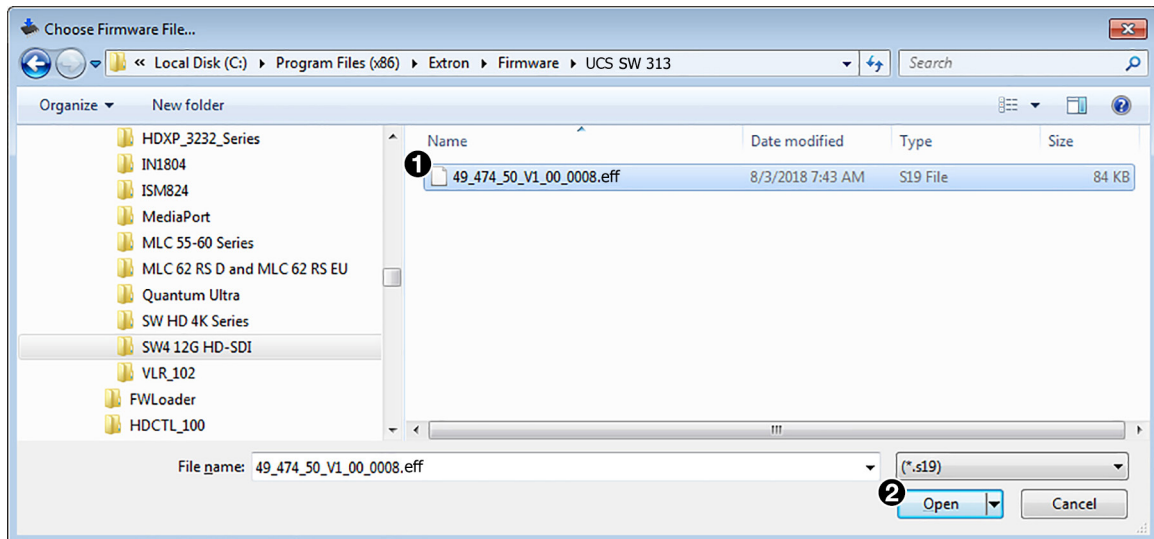

Figure 26. Choose Firmware File Window

ATTENTION:

- Valid firmware files must have the file extension `.eff`. A file with any other extension is not a firmware upgrade for this product and could cause the device to stop functioning.
- Les fichiers firmware valides doivent contenir l'extension fichier `.eff`. Un fichier avec n'importe quelle autre extension n'est pas une mise à jour de firmware pour cet appareil et l'appareil pourrait arrêter de fonctionner.

7. In the Firmware Loader dialog box, click **Begin** (see figure 27, ①).

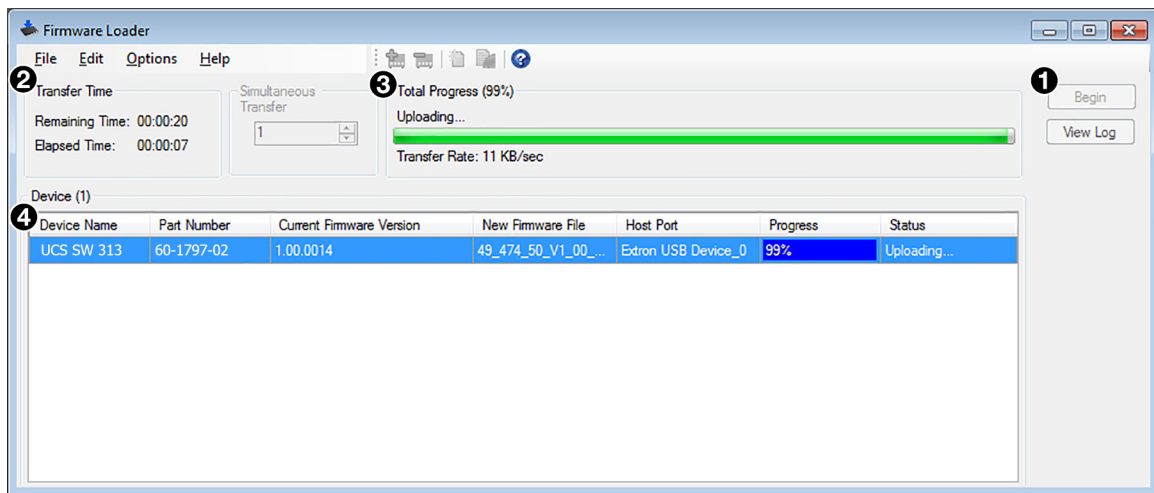

Figure 27. Firmware Upload in Progress

The following indicators show the progress of the update:

- The Transfer Time panel shows the amounts of remaining and elapsed time for the update (②).
 - The Total Progress panel (③) displays a progress bar with `Uploading...` above it.
 - In the Devices panel (④), the Progress column displays an incrementing percentage and another progress bar. The Status column displays `Uploading`.
8. The upload is complete when the Remaining Time panel shows `00.00.00`, the Progress column shows `100%`, and `Completed` is displayed above the progress bar and in the Status column. Close the Firmware Loader dialog box.

NOTE: The original factory-installed firmware is permanently available on the UCS SW 313. If the attempted firmware upload fails for any reason, the switcher reverts to the factory version.

Internal Web Page

The embedded UCS SW 313 web page enables you to monitor and adjust certain settings of the UCS through its Ethernet port, connected via a LAN, WAN, or IP over USB, and using a web browser such as Microsoft Edge®, Google® Chrome®, or Firefox®. This factory-installed web page is always available and cannot be erased or overwritten.

- [Accessing the Web Page](#)
- [Web Page Components](#)

Accessing the Web Page

To access the web page:

1. In the Address field of your web browser, enter either of the following:
 - The IP address of your unit.

NOTE: If the local system administrators have not changed the IP address, use the factory-specified default **192.168.254.254** in this field.

- The IP over USB address: **203.0.113.22**
2. Press the <Enter> key. The sign-in screen of the internal web page opens.
3. On the sign-in screen, enter your user name in the **Username** field (see figure 28, **1**). The default name is **Admin**.
4. If a password has been defined, enter it in the **Password** field (**2**).

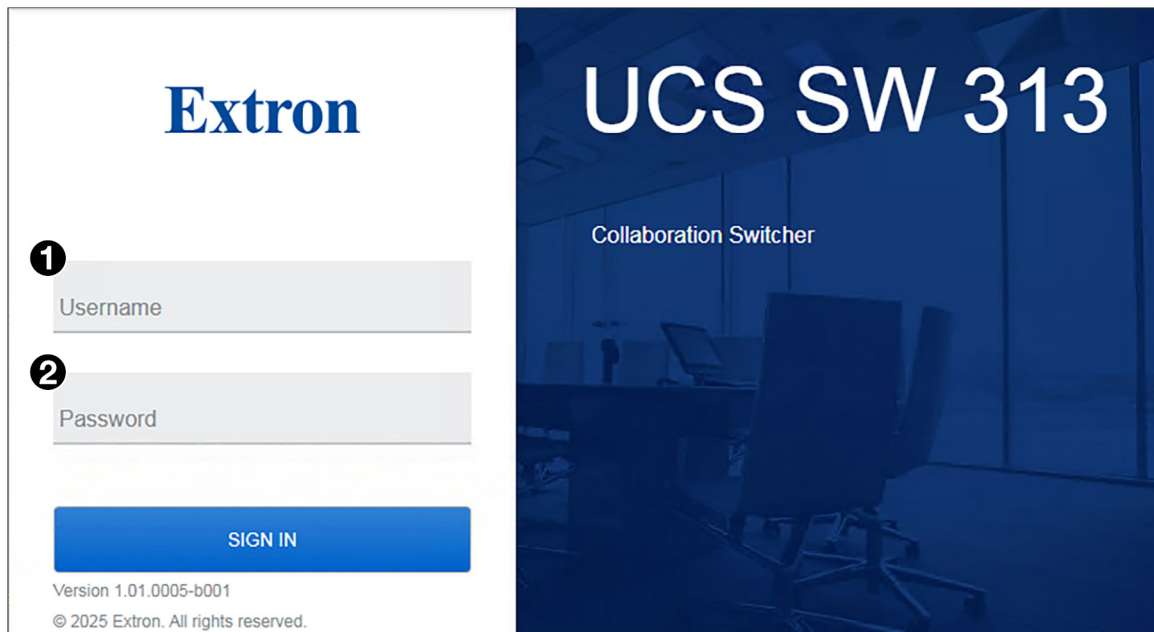

Figure 28. Web Page Sign-in Screen

Web Page Components

The Device Utilities screen contains the following items. To access any of the five Settings drop-down panels, click the down arrow to the right of its name to expand it. To collapse a settings panel when finished editing it, click the up arrow to the right of its name.

UCS SW 313 | UCS-SW-313-2C-C6-7F admin

Device Utilities

1 Details		2 Status	
Hostname	UCS-SW-313-2C-C6-7F	Date and Time	2/22/2025 07:44 PM
Description	Collaboration Switcher	Timezone	(UTC-08:00)
Part Number	60-1797-02	Uptime	1 Day 1 Hour
Serial Number	A32TLXK	Temperature	131.18°F / 55.1°C

Settings

- 3 Date and Time
- 4 Network
- 5 Passwords
- 6 Firmware

1 Details Panel **4 Network Panel**
2 Status Panel **5 Passwords Panel**
3 Date and Time Panel **6 Firmware Panel**

Figure 29. Internal Web Page

Details Panel

This view-only panel contains the following information about the unit (see figure 29, **1**):

- The unit name (Hostname)
- Product description (Collaboration Switcher)
- Part number (60-1797-0n)
- Unit serial number

Status Panel

This view-only panel contains the following unit status information (figure 29, **2**):

- The current date and time (These settings can be configured via the Date and Time panel, see [Date and Time Panel](#) on page 50.)
- The time zone in which the unit is operating (This setting can be configured via the Date and Time panel.)
- Uptime — The amount of days and hours the unit has been running
- The unit internal temperature in Fahrenheit and Celsius

Date and Time Panel

The following settings are available via the Date and Time panel:

Syncing the date and time on the UCS to the PC

To set the unit date and time to match that of the computer:

Click the **SYNC TO PC** button (see figure 30, ①). (Clicking the **EDIT** button first is optional.)

When the sync is completed, the current date and time appear in the **Date | Time** field, followed by a green check mark (②).

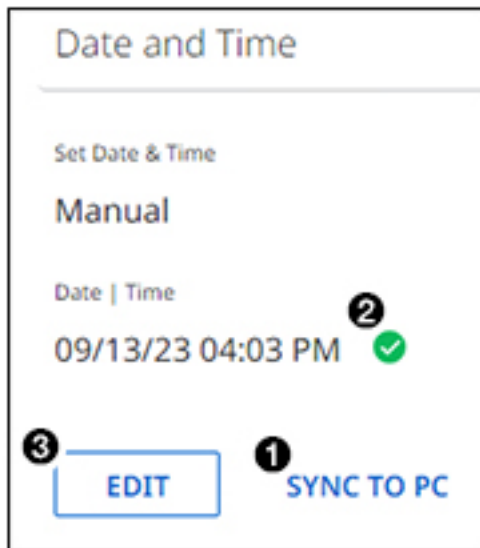

Figure 30. Syncing UCS Date and Time to the PC

NOTE: The Set Date & Time field must be set to Manual. If it is set to Sync to NTP Servers, the **SYNC to PC** button is unavailable. Click **EDIT**, then select the **Manual** radio button and click **SAVE** (see [Syncing to NTP servers](#) on page 52).

Editing the date, time, and time zone manually

To set the date, time, or time zone manually:

1. In the Date and Time panel, click the **EDIT** button (see [figure 30](#), **3** on page 51).

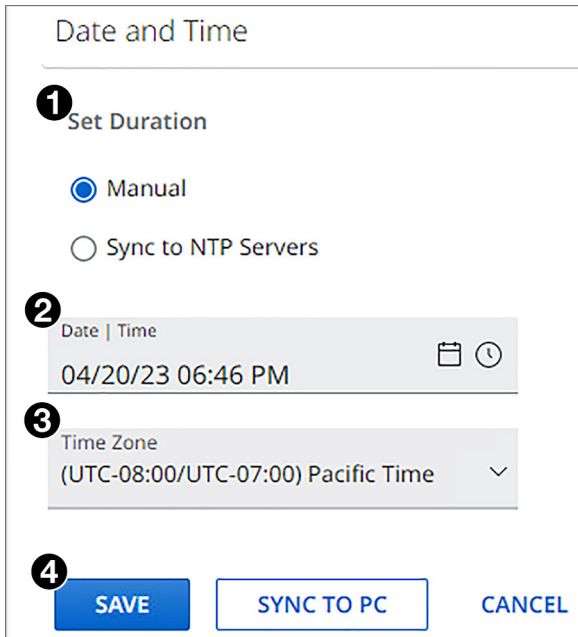

Figure 31. Date and Time Editing Panel

2. Under Set Duration, select **Manual**.
3. On the Date and Time editing panel, set the time, date, and time zone as desired:
 - **Date and Time** — In the **Date | Time** field (see [figure 31](#), **1**), either click on the hour and minute text fields and type in the time, or click the **Datepicker** (see [figure 32](#), **1**) or the **Timepicker** (**2**) icon to display the following panels:

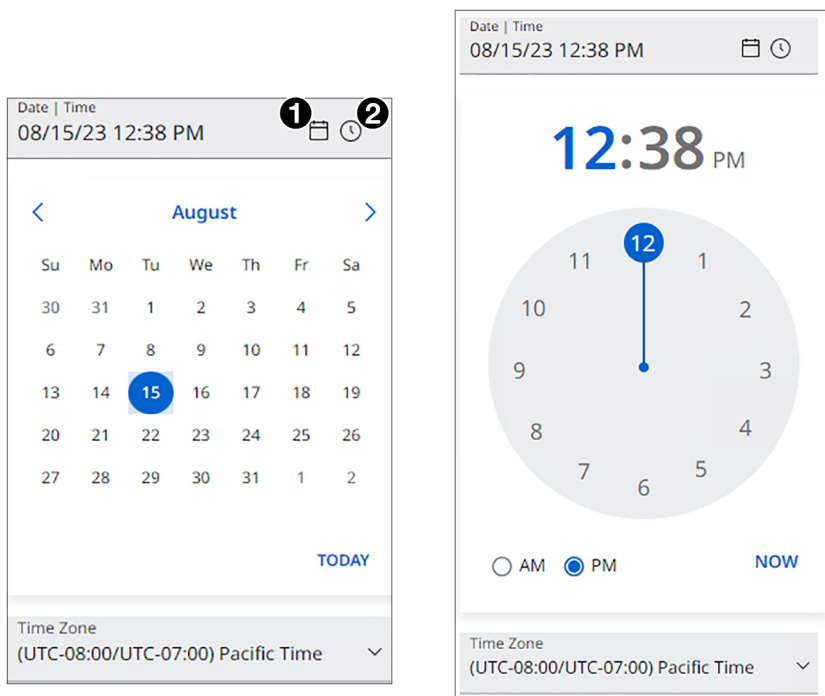

Figure 32. Datepicker and Timepicker Screens

- **Date** — On the Datepicker screen, either select the desired date from the calendar (current month only) or click **TODAY** to display the current date in the **Date | Time** field. To select a different month, click the right and left arrows at the top of the screen to display the desired month and year.
 - **Time** — On the Timepicker screen, click on the hour or minutes above the clock, then click on the desired number on the clock. To display the current time in the **Date | Time** field, click **NOW**. Select the **AM** or **PM** radio button.
 - **Time Zone** — In the **Timezone** field, select the desired time zone for the UCS from the drop-down menu (see [figure 31](#), [3](#) on page 52).
4. When finished entering settings, click **SAVE** ([4](#)) to confirm them, or **CANCEL** to close the dialog box without implementing the settings.

Syncing to NTP servers

To set the date, time, and time zone by syncing the UCS SW 313 with a network server:

Figure 33. Syncing the UCS SW 313 to Network Servers

1. Select the **Sync to NTP Servers** radio button.
2. If desired, select the time zone for the UCS from the **Time Zone** drop-down list (see [figure 33](#), [2](#)).
3. Enter the IP addresses of up to three network servers from which the UCS can obtain the date and time ([3](#)).
4. Click **SAVE** ([4](#)).

When syncing to NTP servers is enabled, the UCS syncs to the server at the address entered in the **NTP Server #1** space. If it fails to connect to server #1, it tries server #2, then server #3.

Network Panel

In the Network panel you can set the hostname, IP address, subnet mask, and gateway address for your UCS SW 313, and turn DHCP on and off. You can also view the MAC address of the unit. To set the IP addresses:

1. Click the down arrow at the right of the **Network** field to view the network settings.

The screenshot shows the 'Network' settings panel. At the top, there is a title 'Network' with an upward-pointing arrow. Below it, the 'Device Name / Hostname' field is set to 'UCS-SW-313-2C-C6-7F' and is marked with a circled '1'. The 'DHCP' toggle switch is currently turned off and is marked with a circled '2'. The 'IP Address' field is set to '192.168.254.254' and is marked with a circled '3'. The 'Subnet Mask' field is set to '255.255.255.0' and is marked with a circled '4'. The 'Default Gateway' field is set to '10.113.112.100' and is marked with a circled '5'. The 'DNS Server' field is set to '0.0.0.0' and is marked with a circled '6'. The 'MAC Address' field is set to '00-05-A6-2C-C6-7F'. At the bottom, there are 'SAVE' and 'CANCEL' buttons, with the 'SAVE' button marked with a circled '7'.

Figure 34. Edit Network Settings Screen

2. Edit the network settings as desired:
 - **Device Name / Hostname** — Enter a name for the unit (see figure 34, **1**).
 - **DHCP** — Click the DHCP button (**2**) to toggle DHCP on and off. When DHCP is enabled (On), the unit configures its IP address and other network settings from the DHCP server. The default is Off.
 - **IP Address (3)**, **Subnet Mask (4)**, **Default Gateway address (5)**, **DNS Server (6)** — To set any of these addresses, click in the desired field and enter the address.
3. When finished editing, click **SAVE (7)** to confirm your changes or **CANCEL** to close the window without making changes. You can also close the window by clicking the X in the upper-right corner of the screen.

NOTE: If DHCP is being enabled, the web page attempts to redirect and connect to the unit via the unit name (TCP/IP hostname). If a static IP address is being set, the web page attempts to connect to the new IP address.

Passwords Panel

NOTE: The factory configured passwords for all accounts on this device have been set to the device serial number. Passwords are case sensitive. In the event of an absolute system reset, these passwords are reset to the default password, which is extron.

To set admin and optional user passwords on the UCS, click the down arrow to the right of Passwords to display the settings.

NOTE: The following rules apply to passwords:

- Length is 1-128 characters.
- All human-readable characters are permitted except |.
- The administrator password can be changed, but it cannot be removed. A user password can be deleted by entering a single space as the password.

Assigning an administrator password

1. In the Passwords panel, click **EDIT**. The password settings are displayed.

The screenshot shows a 'Passwords' panel with the following elements:

- Admin Password** field (masked with dots) with callout 1.
- Confirm Admin Password** field (masked with dots) with callout 2.
- CREATE** button (blue) with callout 3.
- CANCEL** button (grey).
- Show Password** checkbox.
- User P...** section with **Not Set** text and an **EDIT** button with callout 4.

Figure 35. Passwords Panel

2. In the **Admin Password** field (see figure 35, 1), enter the new administrator password. The password appears as masked characters. To see the actual characters, select the **Show Password** checkbox.
3. In the **Confirm Admin Password** field (2), reenter the password from the **Admin Password** field.
4. Click the blue **CREATE** button (3). (You may need to click this button again to make it available.)
The UCS SW 313 web page closes and the login page is displayed.
5. Enter the username (the default is **Admin**) and the new password to access the UCS SW 313 web page.

Assigning a user password (optional)

1. To assign a user password, click **EDIT** (4) in the User Password panel.
2. Repeat steps 2 through 4 in the User panel.

Resetting an assigned admin password to default

1. In the **Admin Password** field, enter a single space.
2. Enter a single space in the **Confirm Admin Password** field.
3. Click **Create**. The password is reset to the default password, which is **extron**.

Removing a user password

The screenshot shows a 'User Password' panel with the following elements:

- User Password** field (masked with dots).
- Confirm User Password** field (masked with dots).
- CREATE** button (blue).
- CANCEL** button (grey).
- Show Password** checkbox.

Figure 36. Removing a User Password

1. In the **User Password** field, enter a single space.
2. Enter a single space in the **Confirm User Password** field.
3. Click **SAVE**. The password is deleted.

Firmware Panel

The Firmware panel displays the current firmware version and the date it was last updated. You can update the firmware on your UCS from this panel (firmware files can be downloaded from www.extron.com).

To update firmware:

1. In the Firmware panel, click the **Select File** button (see figure 37, ❶).

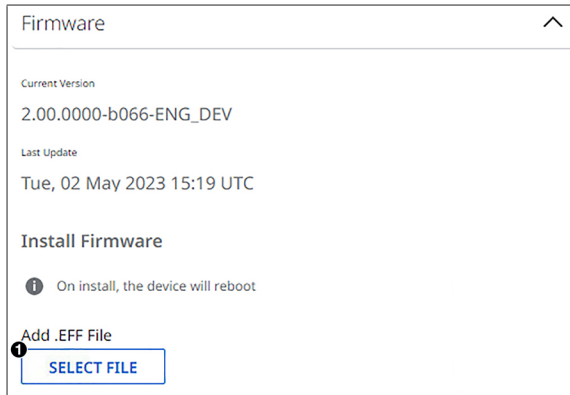

Figure 37. SELECT FILE Button on the Firmware Panel

2. In the Open dialog box, browse to locate the new firmware file on your computer (by default the file is stored at C:\Program Files (x86)\Extron\Firmware).

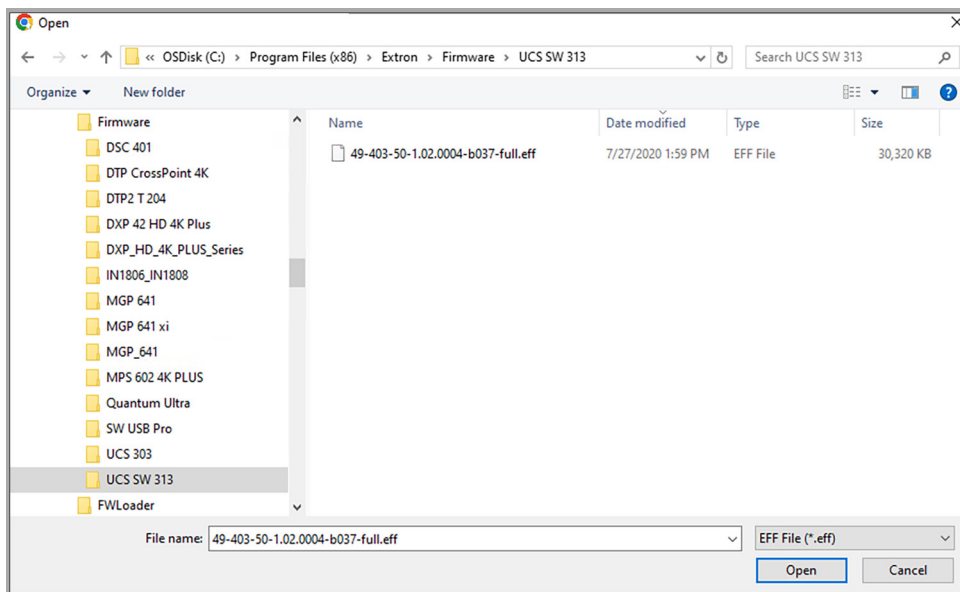

Figure 38. Open Window for UCS SW 313 Firmware

ATTENTION:

- Valid firmware files must have an .eff file extension. A file with any other extension is not a firmware upgrade for this device and could cause the unit to stop functioning.
- Les fichiers firmware valides doivent contenir l'extension fichier .eff. Un fichier avec n'importe quelle autre extension n'est pas une mise à jour de firmware pour cet appareil et l'appareil pourrait arrêter de fonctionner.

3. Double-click the firmware file name. The Open window closes, and the firmware file name appears in the Update Firmware panel on the web page (see figure 39, ①).

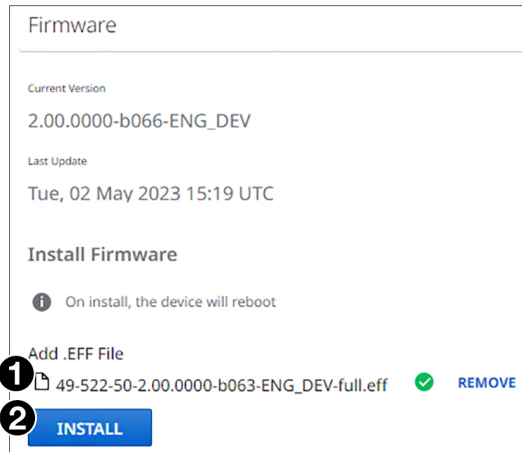

Figure 39. Firmware Update Dialog Box with a Firmware File Selected

4. Click **Install** (see figure 39, ②) to begin uploading the firmware. (If you want to cancel the update, click the X button in the upper-right corner of the Update Firmware panel.)

The Installing Firmware window opens, containing three indicators that show the progress of the update: File Uploading, Installing Firmware, and Rebooting (see figure 40).

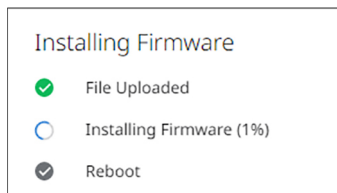

Figure 40. Firmware Update Progress Window

NOTE: While the firmware is uploading and rebooting, do not press any front panel buttons or make any selections on the web pages.

When the update is complete, the unit restarts, and the login web page is displayed. After you log in, the new firmware filename appears under **Current Version** in the Firmware panel of the web page.

Reference Information

This section contains the following topics:

- [Best Practices for Cleaning Your Extron Products](#)
- [Mounting the UCS SW 313](#)

Best Practices for Cleaning Your Extron Products

Depending on the device, application, and location, there may be times when it becomes necessary to clean your Extron product. Frequently touched devices, such as touchscreens and button panels, require regular cleaning to ensure their surfaces remain sanitary. Plastic surfaces and cosmetic finishes can be damaged by long term exposure to chemicals. Therefore, Extron recommends the following guidelines when cleaning our products.

All Extron products can be safely cleaned with:

- 70% concentration or higher Isopropyl Alcohol
- Disinfectant cleaners that:
 - Are non-ammonium based (for example, contains no ammonium chloride).
 - Contain 2% or less sodium hypochlorite (for example, 2% bleach, 98% water).



Regardless of the device, it is important to follow these general guidelines when cleaning:

1. If possible, unplug the device.
2. Spray the cleaner on a lint-free cloth until the cloth is damp.
3. Do not spray the cleaner directly onto the product.
4. Gently clean the product surface using the cloth.

Your health and safety are an Extron priority. Keeping devices clean, especially those in high-traffic environments and high-use applications, is a crucial step in minimizing the spread of infections. Please contact Extron if you have any questions about the guidelines outlined in this section or if you have a question about cleaning a specific Extron product.

Mounting the UCS SW 313

The UCS SW 313 can be set on a table or mounted on a rack shelf.

ATTENTION:

- Installation and service must be performed by authorized personnel only.
- L'installation et l'entretien doivent être effectués uniquement par un technicien qualifié.

Tabletop Use

Attach the provided four self-adhesive rubber feet to the UCS SW 313 for tabletop use. Place the switcher where desired.

Rack Mounting

The UCS SW 313 switcher can be mounted on a full- or half-rack shelf, or through or under furniture. Mounting kits are available at www.extron.com. For mounting procedures, see the instructions provided with the mounting option.

UL guidelines for rack mounting

The following Underwriters Laboratories (UL) guidelines pertain to the safe installation of the UCS SW 313 in a rack.

CAUTION:

- **Elevated operating ambient temperature** — If the equipment is installed in a closed or multi-unit rack assembly, the operating ambient temperature of the rack environment may be greater than room ambient temperature. Therefore, install the equipment in an environment compatible with the maximum ambient temperature (TMA = +122 °F, +50 °C) specified by Extron.
- **Reduced air flow** — Install the equipment in a rack so that the amount of air flow required for safe operation of the equipment is not compromised.
- **Mechanical loading** — When mounting the equipment in the rack, ensure that uneven mechanical loading does not cause a hazardous condition.
- **Circuit overloading** — When connecting the equipment to the supply circuit, consider the effect that circuit overloading might have on overcurrent protection and supply wiring. Consider equipment nameplate ratings when addressing this concern.
- **Reliable earthing (grounding)** — Maintain reliable grounding of rack-mounted equipment. Pay particular attention to supply connections other than direct connections to the branch circuit (for example, use of power strips).

Consignes UL pour le montage en rack

Les consignes UL (« Underwriters Laboratories ») suivantes concernent l'installation en rack d'un boîtier UCS SW 313 :

ATTENTION :

- **Température ambiante élevée** — En cas d'installation de l'équipement dans un rack fermé ou composé de plusieurs unités, la température du rack peut être supérieure à la température ambiante. Par conséquent, il est préférable d'installer l'équipement dans un environnement qui respecte la température ambiante maximale (T_{ma}) spécifiée par Extron.
- **Réduction du flux d'air** — Si l'équipement est installé dans un rack, veillez à ce que le flux d'air nécessaire pour un fonctionnement sécurisé de l'équipement soit respecté.
- **Charge mécanique** — Installez l'équipement en rack de manière à éviter toute situation dangereuse causée par le déséquilibre de la charge mécanique.
- **Surcharge électrique** — Lorsque vous connectez l'équipement au circuit d'alimentation, observez la connexion de l'équipement et étudiez les effets possibles d'une surcharge du circuit sur les protections contre les surintensités et les conducteurs d'alimentation. Consultez à cet égard les indications de la plaque d'identification de l'équipement.
- **Mise à la terre** — Assurez-vous que l'équipement est correctement mis à la terre. Accordez une attention particulière aux connexions électriques autres que les connexions directes au circuit de dérivation (ex. : les multiprises).

Extron Warranty



Extron warrants its powered products against defects in materials and workmanship for a period of three years from the date of invoice. In the event of malfunction during the warranty period, Extron will repair or replace a product to whatever extent it shall deem necessary to restore the product to proper operating condition.

This Limited Warranty does not apply if the fault has been caused by misuse, improper handling care, electrical or mechanical abuse, abnormal operating conditions or non-Extron authorized modification to the product. Extron Electronics makes no further warranties either expressed or implied with respect to the product and its quality, performance, merchantability, or fitness for any particular use. In no event will Extron Electronics be liable for direct, indirect, or consequential damages resulting from any defect in this product even if Extron Electronics has been advised of such damage. Please note that laws vary from state to state and country to country, and that some provisions of this warranty may not apply to you.

Powered Warranty Exception

Everlast™ Power Supplies — Extron warrants Everlast power supplies against any defects in materials and workmanship for a period of seven years from the date of invoice. In the event of a malfunction during the warranty period, Extron will repair or replace the power supply to its original operating condition. Extron engineers will examine the returned product and determine whether the Everlast Power Supply Warranty or Powered Product Warranty applies.

Speakers — Extron warrants Flat Field®, SoundField®, SpeedMount®, Column Array, and System INTEGRATOR® speakers against any defects in materials and workmanship for a period of five years from the date of invoice.

Touchscreens — Extron warrants touchscreen display and overlay components against any defects in materials and workmanship for a period of one year from the date of invoice.

Annotator 300 — Extron warrants the Annotator 300 against any defects in materials and workmanship for a period of five years from the date of invoice.

Non-Powered Warranty Exception

Cable Cubby, Hideaway Surface Access Enclosures and Retractors — Extron warrants Cable Cubby cable access enclosures, HSA Hideaway Surface Access enclosures, and Retractor cable retraction modules for a period of three years from the date of invoice.

Active Cables and Active Adapters — Extron warrants active cables and active adapter cables for a period of three years from the date of invoice.

Cable Termination Tools and Dies — Extron warrants cable termination tools for a period of three years from the date of invoice, excluding the die.

Return Information

Units must be returned insured, with shipping charges prepaid. If not insured, you assume the risk of loss or damage during shipment. Returned units must include the serial number and a description of the problem, as well as the name of the person to contact in case there are any questions.

NOTE: To assure the highest level of service, a return authorization number must be obtained from Extron before products are returned for service. Products must be shipped to Extron, prepaid along with proof of purchase **only** after obtaining a Return Authorization (RA) number from the Extron Customer Support department.

Please contact Extron to receive an RA (Return Authorization) number:

USA: 714.491.1500 or 800.633.9876

Asia: 65.6383.4400

Europe: 31.33.453.4040 or 800.3987.6673

Japan: 81.3.3511.7655

Africa and Middle East: 971.4.299.1800