

## User's Manual



## *SCP 100 Control Pad* System 5α Accessories



## Chapter One - Installation

System 5 <sub>cr</sub> Options: SCP 100 .....	1-1
Installing the SCP 100 (60-270-01, 02 & 03) .....	1-1
Electrical Wall Boxes .....	1-2
Making Cables .....	1-3
Testing the SCP 100 .....	1-4

## Chapter Two - SCP 100 Operation and Reference

SCP 100 Operation .....	2-1
Room Button and LED .....	2-1
Display Controls .....	2-2
Audio Controls and Indicators .....	2-2
Five Input Select Buttons .....	2-2
Extron's Comm-Link Cable .....	2-3
Part Numbers .....	2-3
Engineering Drawing (not to scale) .....	2-4
Cutout Template (drawn to scale) .....	2-5
Index for System 5 manual .....	2-7

The following icons may be used in this manual:

 — *Important information – for example, an action or a step that must be done before proceeding.*

 — *A Warning – possible dangerous voltage present.*

 — *A Warning – possible damage could occur.*

 — *A Note, a Hint, or a Tip that may be helpful.*

### Other reference material

System 5 Switching system – System 5 manual (68-388-01)  
 Index – System 5 manual (68-388-01)  
 Glossary of terms – System 5 manual (68-388-01)  
 IR Broadcaster manual (68-392-01)  
 Power Sensor manual (68-391-01)  
 IR 40 Instruction card (68-405-01)

*SCP 100 User's Manual  
 (used with System 5<sub>cr</sub> Switcher)  
 68-390-01, Rev. A, 99-02*





# **Chapter One**

## **Introduction and Features**

*SCP 100 Installation*

*Installing Electrical Boxes*

*Making Cables*

*Specifications*

## System 5<sub>cr</sub> Accessories: SCP 100

 — For simplicity, the System 5<sub>cr</sub> is often referred to as System 5.

There can be one or two optional SCP 100 remote panels installed on a System 5. All of the System 5 front panel normal operation functions can be controlled from an SCP 100, except for the Setup (Config) procedures.

Signals received by the SCP 100's IR port are transferred by hard-wired cable to the System 5. For details on front panel operations, see the System 5 User's Manual (68-388-01).

 — Setup, or "Config" cannot be done from an SCP 100.

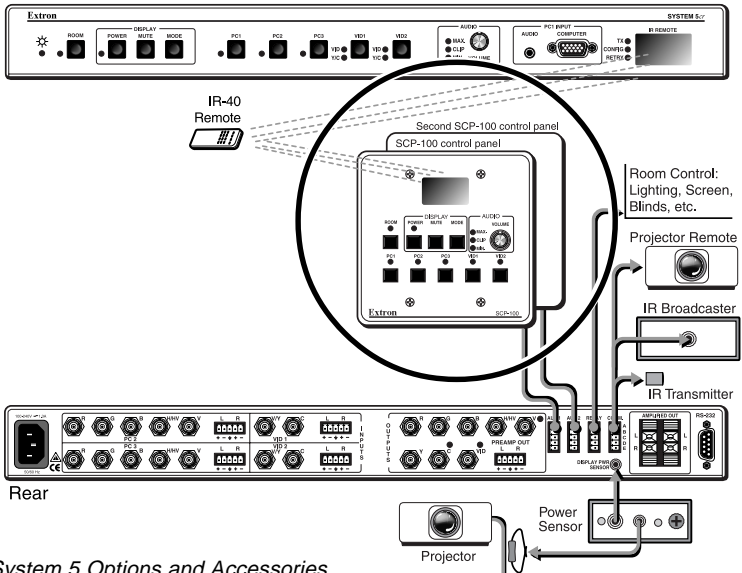

Figure 1-1. System 5 Options and Accessories

The SCP 100 can be mounted in a wall, podium, table, etc., using a standard, 2-gang electrical box, as illustrated in Figure 1-2. How and where it mounted is the decision of the system designer.

Each SCP 100 is connected to the System 5 by a cable, using 3.5 mm, 5-pole captive screw connectors. The connectors are provided with each unit, however, because cable length requirements vary, cables are the responsibility of the installer.

### Installing the SCP 100 (60-270-01, 02 & 03)

The SCP 100 is designed to be used with standard electrical wall boxes, such as those used for light switches. Figure 1-2 shows how it can be installed in a wall, desk, podium, etc. The procedures provided here assume that the electrical wall boxes have been installed and the cable(s) have been run for the interface system.

## Electrical Wall Boxes

- ▲ — When installing the SCP 100, adhere to all country, state and local electrical codes.
- ▲ — Extron provides an electrical box with each SCP 100. However, you may choose a different box. Because of the loose tolerances for electrical boxes, it is recommended that you measure the exact box that you plan to use before making any precise cuts. Also refer to the box dimensions (2.5" deep), and not the SCP 100 dimensions.

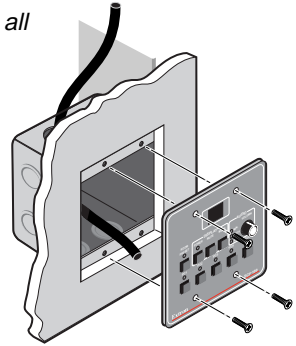

Figure 1-2. The SCP 100 mounts in a standard electrical wall box.

Page 2-5 has a template that may be used for cutting a hole to accommodate an SCP 100 and the electrical box.

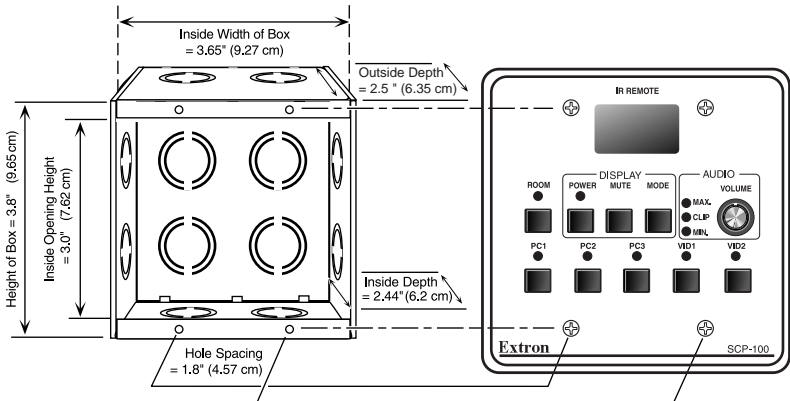

Figure 1-3. A standard electrical wall box dimensions

Use screws, bolts or nails to install the electrical box, depending upon the type and thickness of the material to which the box is being attached. See examples in Figure 1-4.

- For wood, use four #8 to #10 wood or sheet metal screws. A minimum of 1/2 inch (1.25 cm) of screw threads must penetrate the wood. If the wood material is a 2x4, such as a wall stud, 10-penny or larger nails may be used.
- For attaching the electrical box to metal, use four #8 to #10 sheet metal screws (self-tapping) or #8 to #10 machine bolts with matching nuts.

- ▲ — The electrical box must be deep enough to accommodate the electronics within the SCP 100 unit, as well as the cable.

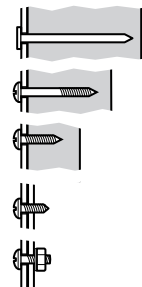



Figure 1-4. Use screws, nails or bolts to attach the electrical box.

## Making Cables

Extron provides the 3.5 mm captive screw connectors with the SCP-100, however a cable will have to be made to fit your installation requirements. Wire the cable to be used between the System 5 connector marked Aux1 or Aux2 (rear panel) and the SCP 100 for a one-to-one configuration (wire pin #1 of one connector to pin #1 of the other, #2 to #2, etc.) The contact assignments are shown in Figure 1-5. Both ends of the cable use a 3.5 mm, captive screw connector. No soldering is required for this connector, simply insert the wires as shown in Figure 3 and tighten the screws.

 — The maximum cable length for an SCP 100 to System 5 application is 300 feet (91.4 meters).

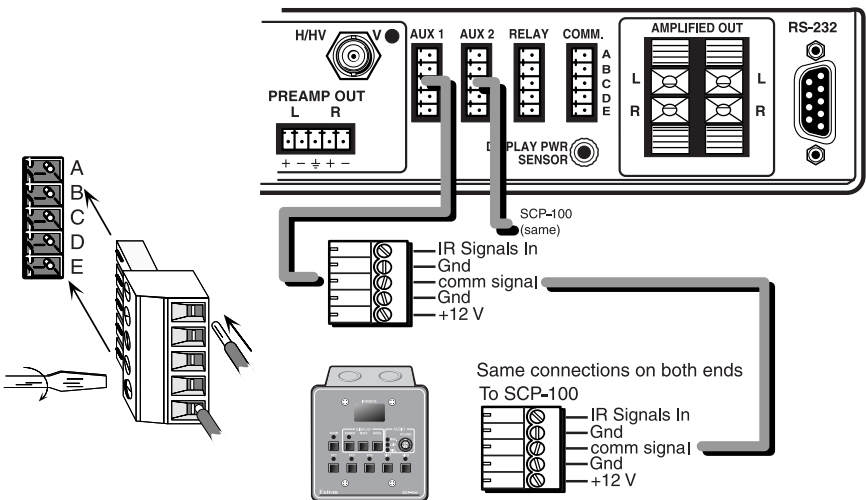

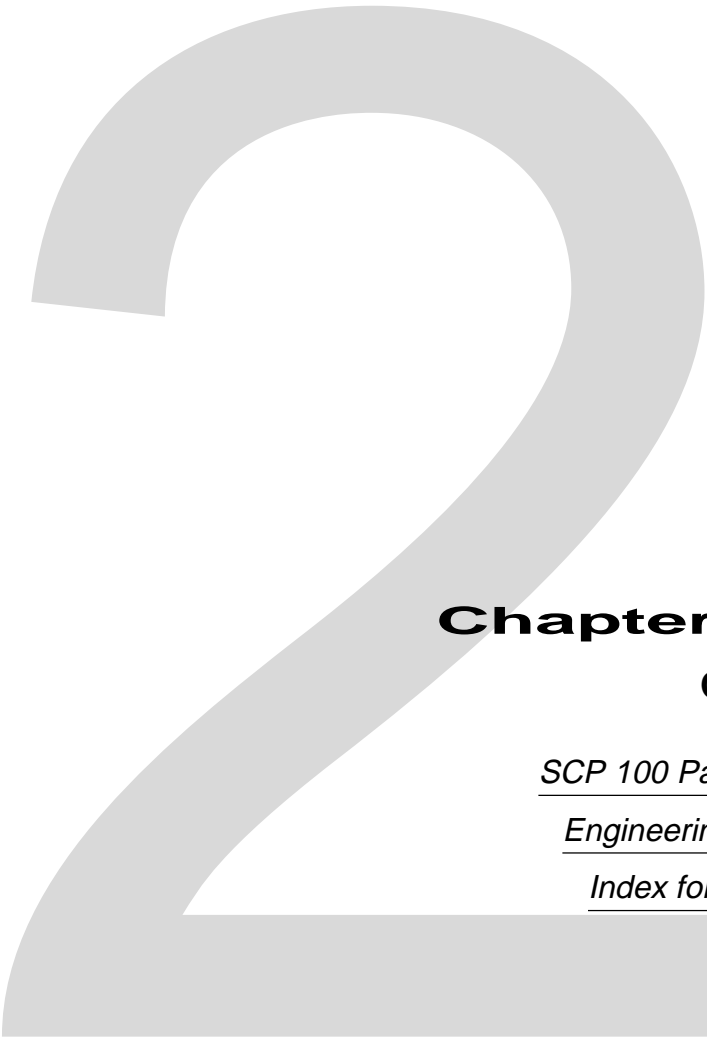

Figure 1-5. Contact assignments for SCP 100 to System 5 connections

## Testing the SCP 100

When finished, either end of the cable can plug to either device. However, because there will be +12 volts from the System 5, it is best to plug the cable to the SCP 100 first, and then to the System 5. There is no setup procedure for this device. Proceed with the operation of the panel(s) to verify that it is working properly.

 — The IR 40 remote can be used from a distance of up to 100 feet (30.5 meters) from the SCP 100 IR port.



**Chapter Two**  
**Operation**

*SCP 100 Panel Buttons*

*Engineering Drawings*

*Index for System 5cr*

## SCP 100 Operation

The SCP 100 panel replicates the normal operations of the front panel. The function names are the same. As stated earlier, Setup (or Config) Mode operations cannot be done from the SCP 100.

The IR Remote port receives IR 40 signals and sends them to the System 5 by the cable. Signals from other IR devices are blocked at the System 5.

Any “learned” IR commands that are stored in the System 5 memory will be transmitted from the System 5’s IR emitter or the optional IR Broadcaster when the associated button is pressed on the SCP 100 panel, just as it will when that same front panel button is pressed.

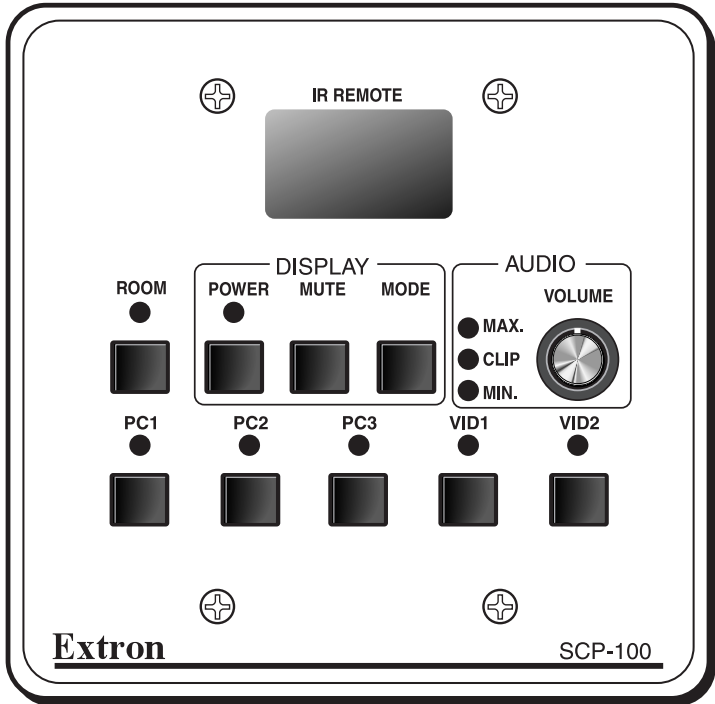

Figure 2-1. SCP 100 panel controls are similar to those on the front panel.

### Room Button and LED

This button and LED work with the relay contact connections provided on the rear panel of the System 5. The button can activate/deactivate a room condition, such as turn lights on/off and raise/lower a viewing screen. The LED indicates when the condition exists. Exactly how the feature is used depends upon the user-defined application and what is connected to the “Relay” connector on the rear panel.

The Room button can operate in one of two ways: latching (press on, press off) or momentary (press on, release off). This programming can **only** be done through Windows® Control Program (RS-232).



– For example, pressing the Room button once could lower a screen and turn room lights off and the LED will remain lit. Press the button again to turn the room lights on, raise the viewing screen and the LED goes out.

## Display Controls



— These buttons only function after being programmed. (See Setup Mode Procedures in the System 5 manual or product label.)

**Power** – After this button has been setup to learn the power on and off from the projector's IR remote control, it will power the display device on or off. There is a power up and power down delay for many projectors. The Display Power LED will blink fast during projector power up and will blink slowly during projector power down. The blinking time is generated within the System 5, and its duration can be programmed through RS-232. The blink duration does **not** come from the projector.

**Mute** – This button functions as the display's Mute on/Mute off switch, after it has learned the video mute signal from the projector's IR remote.

**Mode** – Effective on display devices that do not automatically detect the type of video signal, this button changes the mode of the display device between computer-video, composite video and S-Video. This also takes the place of the single-button (step) mode function found on some projector remote controls.

## Audio Controls and Indicators

The Audio **Volume** Control knob and LEDs for the amplified output.

**Max LED** – lights when the audio output level control has reached its maximum point. This does not indicate the audio level.

**Clip LED** – lights when the output level is beginning to overdrive (peak). This indicator is used to set the audio attenuation for the inputs. Clip level is when this LED blinks occasionally.

**Min LED** – lights when the audio output level control has reached its minimum point. This does not indicate the audio level.



– When all audio inputs have been set up to the same level coming into the System 5, the Volume knob functions as the master volume control for the amplified output. (See Setup Mode Procedures.)

## Five Input Select Buttons

**PC1** – select button for PC Video and Audio. This selects the input from the VGA/Audio connectors on the System 5 front panel.

**PC2** and **PC3** – select buttons for an RGBS or RGBHV source (and audio) from the PC2 or PC3 sections of the rear panel. This could be from a computer or through a computer-video interface.

**VID1** and **VID2** – select buttons for the two Composite Video or S-Video inputs sources (VCR, DVD, etc.)

## Extron's Comm-Link cable

Comm-Link cable was designed for installations such as the System 5. You may choose to use this or a similar low-loss cable.

Pin assignments and suggested Wire usage is as follows:

- A = Signal without carrier (violet or blue) = 22 AWG
- B = Ground (black) = 18 AWG
- C = Signal with carrier (white) = 22 AWG
- D = Ground (Drain) = 24 AWG
- E = +12V (red) = 18 AWG

### Comm-Link Cable

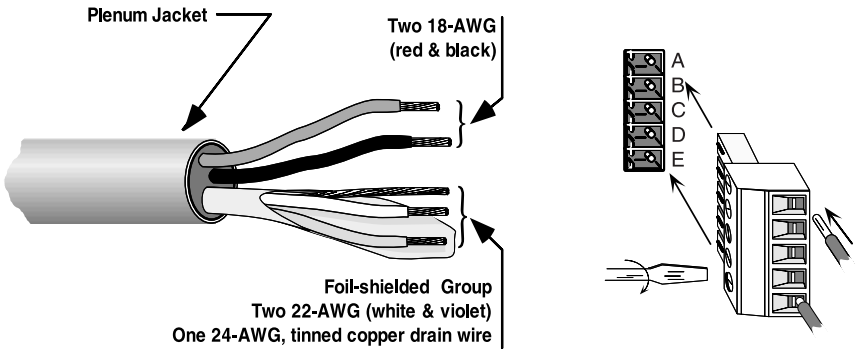

Figure 2-2. Extron's Comm-Link cable was designed for use with the SCP 100.

### Part Numbers

Comm-Link Cable:Cut lengths	Part #	
	50 feet	26-461-01
	100 feet	26-461-02
	200 feet	26-461-03
	400 feet	26-461-04
<b>Bulk spools:</b>		
	500 feet	22-119-02
	1,000 feet	22-119-03
<b>SCP 100 Panels:</b>		
	Gray	60-239-01
	Black	60-239-02
	White	60-239-03
<b>Captive Screw Connector:</b>		
	5-pole, 3.5 mm	10-319-10
(included with each SCP 100)		

**Engineering Drawing (not to scale)**

This drawing may be used to show dimensions and parts of the SCP-100 panel.

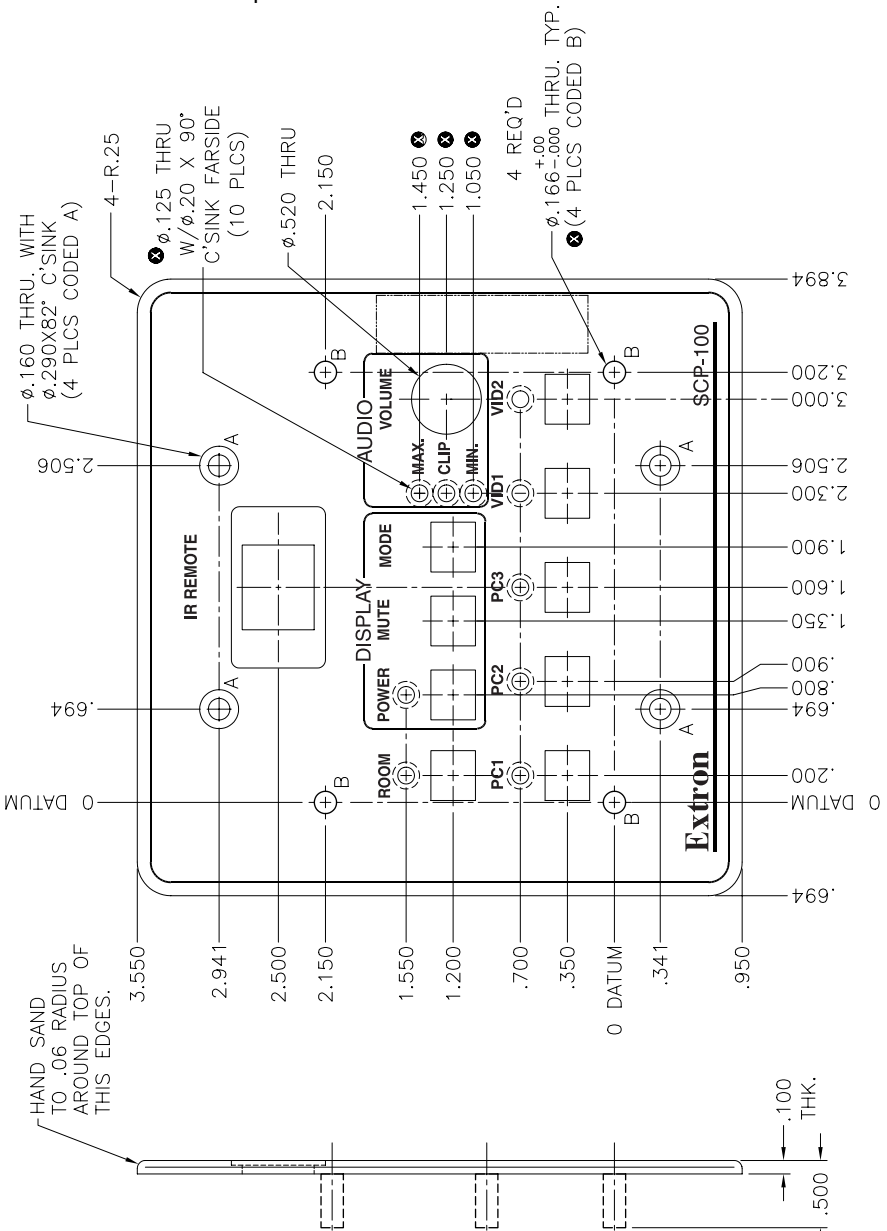

Figure 2-3. Not-to-Scale engineering drawing

### Cutout Template (drawn to scale)

This drawing may be used as a template for cutting a hole to accommodate a 2-gang electrical box. However, because of the loose tolerances for electrical box dimensions, it is recommended that you measure the exact box that you plan to use before making any critical cuts.

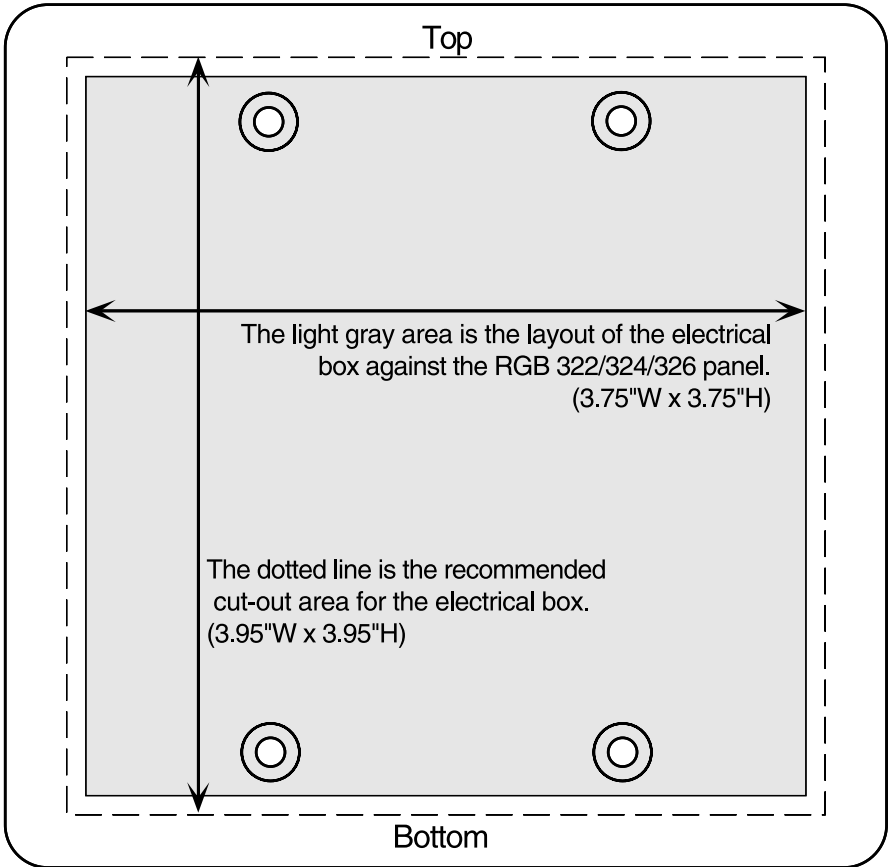

Figure 2-4. Scale drawing for cutting hole.