

CA 83T Column Array Speaker • Setup Guide



IMPORTANT NOTE:

Go to www.extron.com for the complete user guide, installation instructions, and specifications before connecting the product to the power source.



ATTENTION: DO NOT discard the packaging foam end caps. These are needed for the installation.

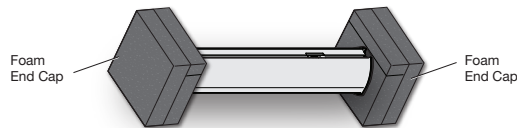

Figure 1. CA 83T Speaker with Foam End Caps

⚠ WARNING: Potential risk of severe injury. Installation and service must be performed by authorized personnel only.

AVERTISSEMENT : Risque potentiel de blessure grave ou de mort. L'installation et l'entretien doivent être effectués par le personnel autorisé uniquement.

NOTE: Observe all applicable building codes and local ordinances when installing the CA 83T speaker.

The CA 83T Column Array Speaker setup guide provides instructions for an experienced installer to mount the Extron CA 83T series column array speaker and wiring connections.

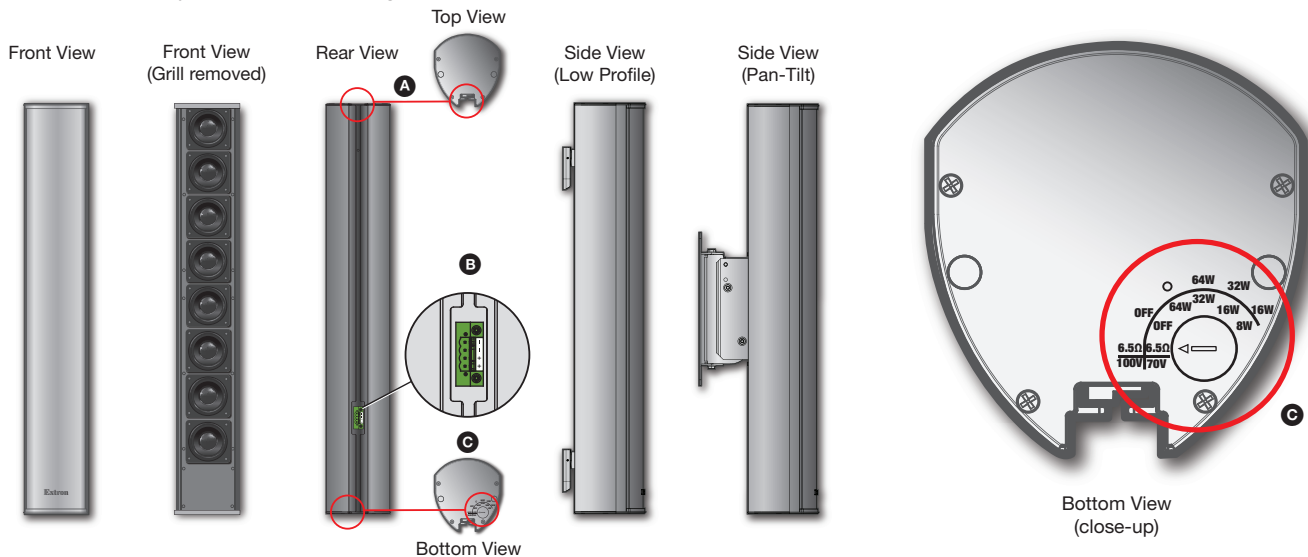

Figure 2. CA 83T Product Diagram

- A** Mounting Bracket T-slot (see figure 2) — Runs the entire length of the speaker enclosure. Carriage Bolts (for SMK LP CA 83T) or Anchor Plates (SMK PT CA) can slide in through either end to the desired locations. Secure and re-adjust if needed.
- B** 4-pole 5mm captive screw input connector — For installing speaker wires, see [Speaker Wiring Options](#) on page 9.
- C** Rotary Tap Selector Switch — Set the rotary tap selector switch to the appropriate setting using a small screwdriver.

ATTENTION:

- When setting the taps for a distributed (high impedance) system, do not set above the rated power of the amplifier.
- Lors de la mise en place des capteurs pour un système distribué (haute impédance), n'exploitez pas le système au delà du niveau d'alimentation de l'amplificateur.
- When connecting multiple speakers in 8-ohm mode, be sure that the combined rated impedance does not equal a value less than the minimum rated impedance of the amplifier.
- Lors de la connexion de plusieurs enceintes en mode 8 ohm, assurez vous que le niveau d'impédance combinée ne soit pas équivalent à une valeur inférieure à l'impédance minimum de l'amplificateur.

CA 83T Speaker • Setup Guide (Continued)

Mounting Options

The CA 83T column loudspeaker can be wall mounted with either of the following mounting options:

SMK LP CA Low-Profile Mounting Bracket Kit — mounts flat; can be adjusted for $\pm 2.5^\circ$ and $\pm 5^\circ$ tilt.

SMK PT CA Pan-Tilt Mounting Bracket Kit (see page 4) — allows up to 15° tilt and $\pm 74^\circ$ panning.

NOTE: Do not discard the Mounting Template or foam end caps until entire installation process is complete.

SMK LP CA Low-Profile Mounting Bracket Kit

The SMK LP CA Low-Profile Bracket allows for the CA 83T column loudspeaker to be positioned flat against the wall (less than 1" off the surface), where little to no tilt is required (up to $\pm 5^\circ$ tilt max).

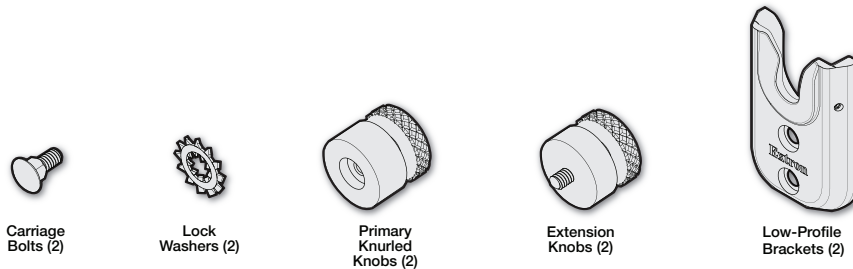

Figure 3. SMK LP CA Low-Profile Bracket Kit

Mounting the Low Profile Wall Brackets

1. Position the CA 83T mounting template, side B (see figure 4), to the wall where you want to mount the speaker. Use a pushpin or piece of tape to secure the top end of the template to the wall (1). Ensure the template is level, then secure the bottom end with an additional pushpin or piece of tape (2).
2. Mark four screw locations or drill four pilot holes through the template (3), for four screws (not included) to secure two Low-Profile Brackets to the wall.
3. When marking or drilling is complete, remove the template from the wall. DO NOT discard the template.
4. If necessary, cut a hole in the wall to route cables to the CA 83T speaker.
5. If not done already, drill four pilot holes through the marked locations on the wall.
6. Use appropriate hardware to securely attach the low-profile brackets to the wall (4) (example – using #14 x 1 3/4" self-tapping wood or metal screws and 1/4" SAE washers). **DO NOT** mount Low-Profile Brackets over the Mounting Template.

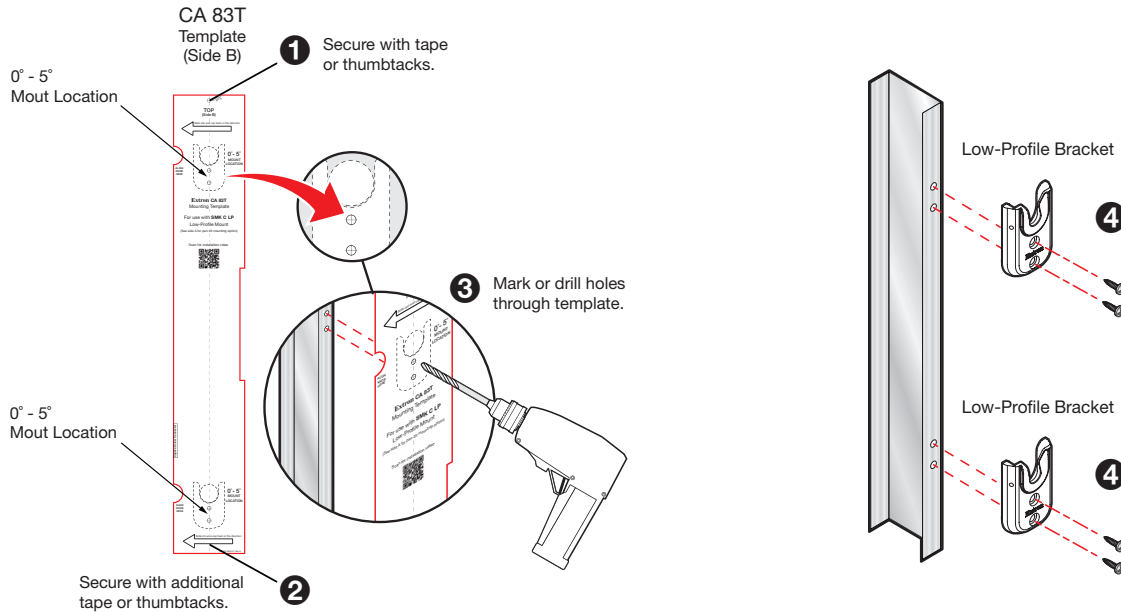

Figure 4. Installing the SMK LP CA Low-Profile Brackets

Mounting Carriage Bolts and Knurled Knobs onto the Speaker

1. Remove the CA 83T speaker from the box and set face-down on a flat surface with the two foam caps still attached. Note the input connector is on the bottom end of the speaker.

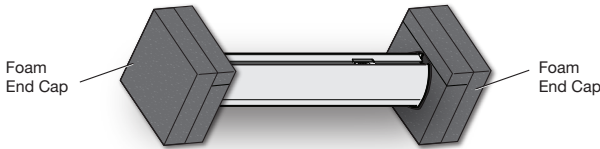

Figure 5. CA 83T with Foam End Caps

2. Brace the top end of the speaker with your hand as you remove the top foam cap (see figure 6, ①). Slide two included carriage bolts and washers into the T-slot (②), and place the foam cap back on the speaker.

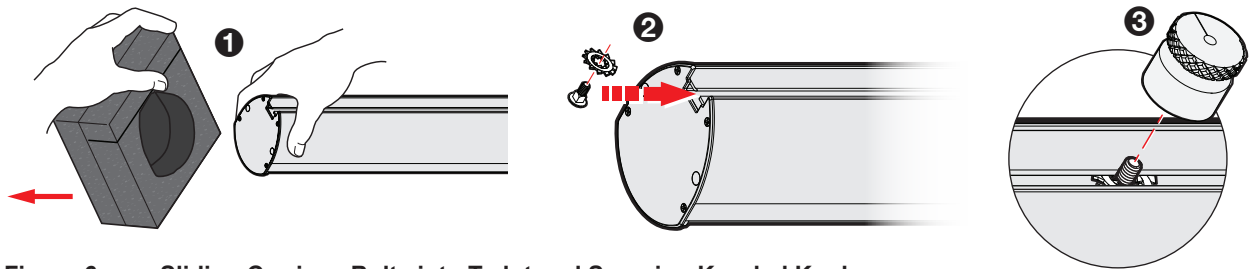

Figure 6. Sliding Carriage Bolts into T-slot and Securing Knurled Knobs

3. Screw the two Primary Knurled Knobs onto the two carriage bolts (③). Do not tighten. The knobs should be loose enough to slide up and down the T-slot.
4. Find the slotted grooves on the foam end pieces and slide in the template with side “B” facing up.

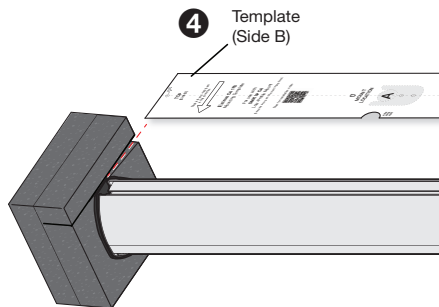

Figure 7. Insert Mounting Template side “B” into Foam Slots

5. Align the Knurled Knobs into the mount positions and tighten to secure. Tighten the knobs an additional 1/4 turn for safety.

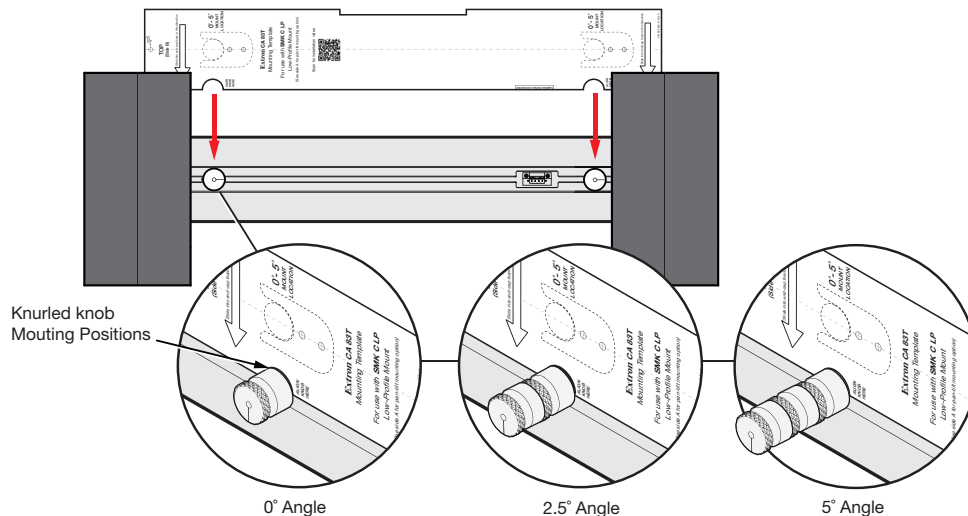

Figure 8. Align and Secure Speaker Bracket Assembly

6. To add tilt, screw one or both 2.5° Extension Knobs onto the desired Primary Knob (see figure 8).

CA 83T Speaker • Setup Guide (Continued)

Mounting the Speaker onto the Wall Brackets

NOTE: If cable ties are required, mount the **Secondary Tie-off** (see page 9) onto the T-slot before mounting the speaker assembly.

1. Slide the two Knurled Knobs into the two Low-Profile Brackets (see figure on the right, **1**).
2. Using a 5/64" or 2 mm hex wrench, secure the speaker in place by tightening one or both set screws (**2**) for each bracket.
3. If more than 5° tilt is required, see **SMK PT CA Pan-Tilt Mounting Bracket Kit** below.

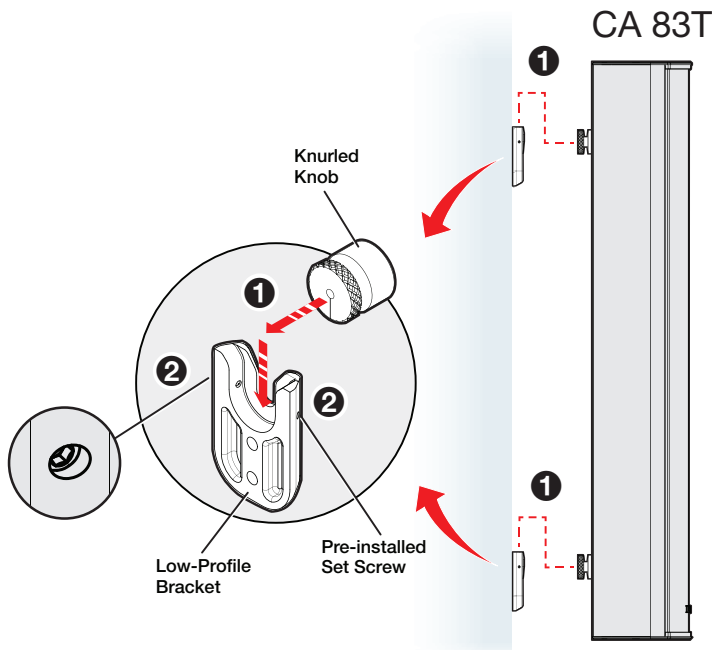

Figure 9. Securing the CA Speaker Low Profile Mount

SMK PT CA Pan-Tilt Mounting Bracket Kit

The SMK PT CA Pan-Tilt mounting bracket kit allows the speaker to be placed in a wide array of positions. When the bracket is secured to the wall, the installer can fasten the column to the bracket and make fine adjustments without carrying the weight of the speaker.

Discrete precision tilt angles are available for 0°, 5°, 10°, and 15° stops. There are also continuously adjustable angles from 0° to 15° provided in the slot.

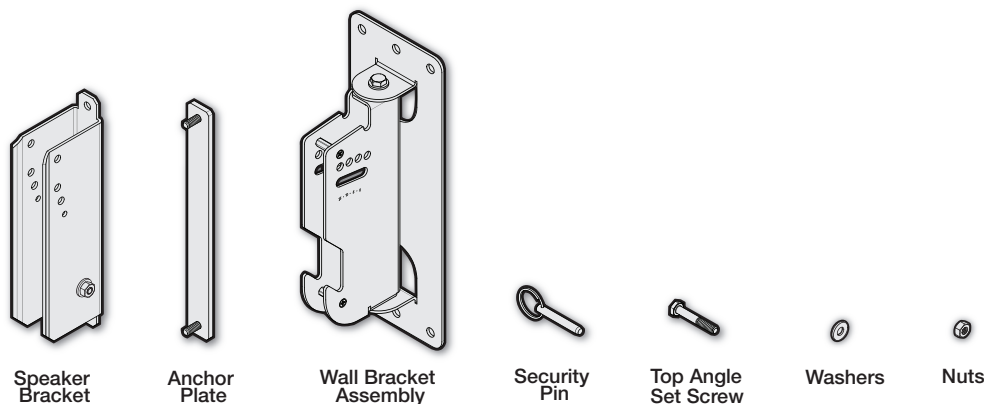

Figure 10. SMK PT CA Pan-Tilt Bracket Kit

Mounting the Pan-Tilt Wall Bracket Assembly

1. Position the included CA 83T mounting template, side A, (see figure on the right) to the wall where you want to mount the speaker. Use pushpin or tape to secure template to the wall (1). Ensure the template is level and secure the bottom with an additional pushpin or piece of tape.

NOTES:

- If the Wall Bracket Assembly cannot be attached to at least two wall studs, then attach one end of the assembly to the wall using one stud and attach the other end using two (not included) 1/4" Kap Toggles.
- If the studs must align with the middle of the Wall Bracket Assembly, secure the assembly to the studs using two screws, and to the wall using two (not included) 1/4" Kap Toggles (one on the leftmost top slot and one on the rightmost top slot).

2. Mark or drill the the wall stud locations through the template (3) where four screws (not included) will secure the Wall Bracket Assembly to the wall.
3. When marking is complete, remove the template from the wall. Set aside, but DO NOT discard.
4. If necessary, cut a hole in the wall to route cables to the CA 83T speaker.
5. If not already done, drill four pilot holes through the marked locations on the wall.
6. Use appropriate hardware to securely attach the Wall Plate Assembly to the wall studs (4). (for example - using #14 x 1 3/4" self-tapping wood or metal screws and 1/4" SAE washers)

DO NOT mount Wall Bracket Assembly over the Mounting Template.

CA 83T
Template
(Side A)

- 1 Secure with tape or thumbtacks.

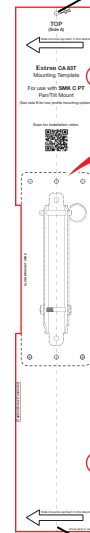

- 3 Mark or drill holes through template.

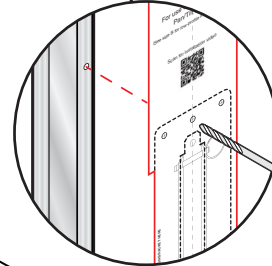

- 2 Secure with additional tape or thumbtacks.



Use mounting screws
(not included) to secure.

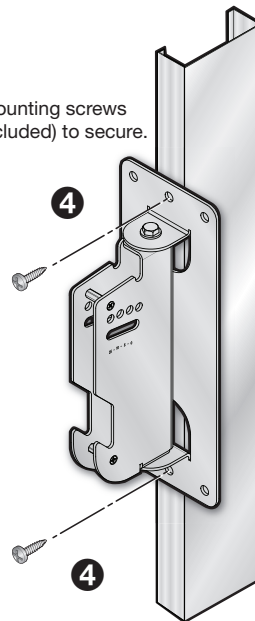

Mounting the Speaker Bracket and Anchor Plate onto the Speaker

1. Remove the CA 83T speaker from the box and set face-down on a flat surface with the foam end caps still attached. Note the input connector is on the bottom end of the speaker.

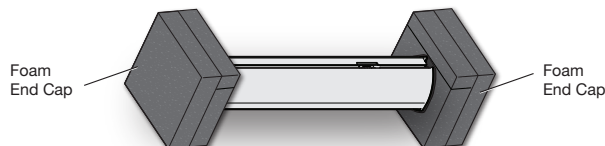

Figure 11. CA 83T with Foam End Caps

CA 83T Speaker • Setup Guide (Continued)

2. Brace the top of the speaker with your hand as you remove the top-end foam piece (❶). Slide the Anchor Plate into the T-slot (❷), and place the foam piece back on the speaker.

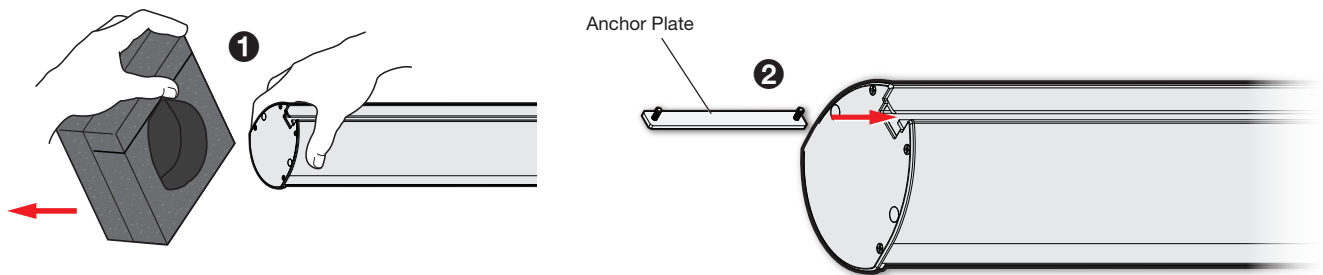

Figure 12. Sliding Anchor Plate into T-slot

3. Secure the Speaker Bracket to the anchor plate with two supplied washers and nuts. Do not tighten. The Speaker Bracket assembly should be loose enough to slide up or down the T-slot.

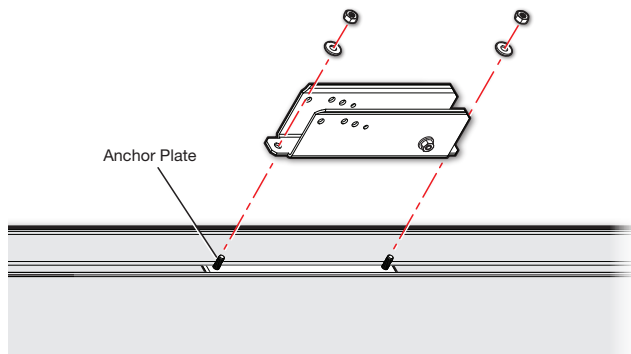

Figure 13. Securing Speaker Bracket to Anchor Plate

4. Find the slotted grooves on the foam end pieces and slide in the template, with side “A” facing up.
5. Align the Speaker Bracket assembly with the rectangular cutout and tighten the two nuts to 85-90 in-lb (7.0 - 7.5 ft-lb) (9.6 - 10.1 N-m) to secure the Speaker Bracket in place.

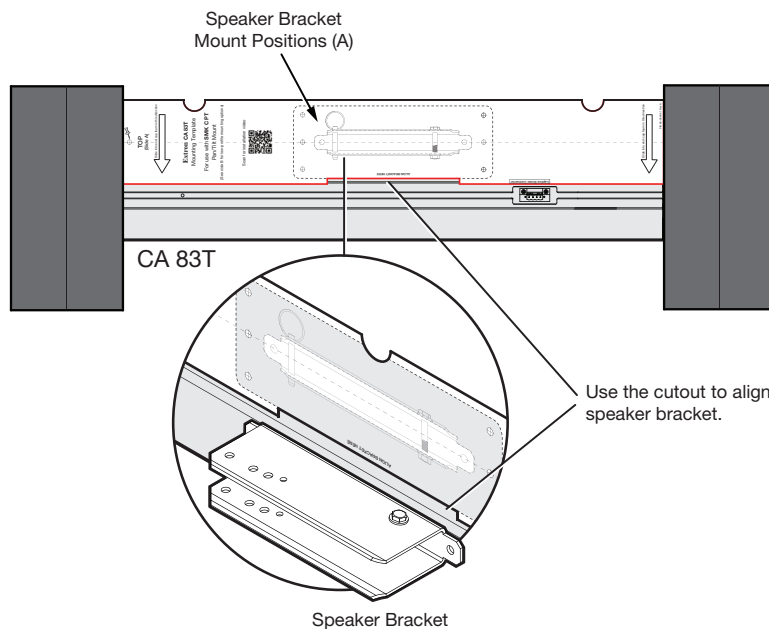

Figure 14. Align and Secure Speaker Bracket Assembly

Mounting the Speaker onto the Pan-Tilt Wall Bracket Assembly

NOTE: If cable ties are required, mount the [Secondary Tie-off](#) (see page 9) onto the T-slot before mounting the speaker assembly.

1. Insert the Security Pin in top hole of Speaker Bracket.

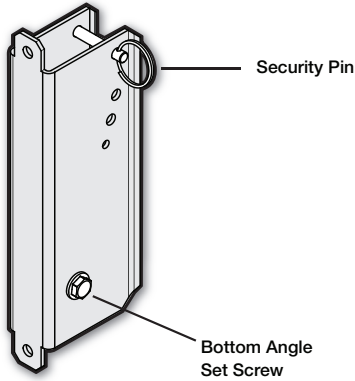

Figure 15. Security Pin and Bottom Angle Set Screw

2. Attach speaker to Wall Bracket Assembly by lowering the Speaker Bracket and bottom Angle Set Screw onto the Wall Bracket Assembly mounting hooks (see figure 15, ①) and push speaker towards the wall until the Security Pin locks into the Security Pin Hook (②).

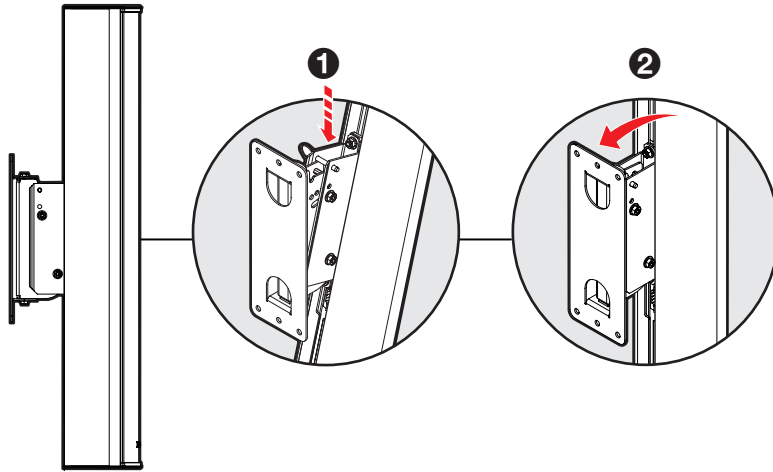

Figure 16. Attaching Speaker to Wall Mount

The speaker is now fully supported by the wall mount, though not fully secured. Refer to [Adjusting the Pan-Tilt Bracket Angles](#) on page 8 for the next steps.

CA 83T Speaker • Setup Guide (Continued)

Adjusting the Pan-Tilt Bracket Angles

Adjusting Tilt Angle

If the speaker is to be set at 0°, then insert an Angle Set Screw in the 0° hole of the Wall Bracket Assembly through the Speaker Bracket.

If the speaker is to be set at an angle of 5, 10, or 15°, gently pull speaker from the top to free the Security Pin from the Security Pin Hook. Align Speaker Bracket with the Wall Bracket Assembly to the required angle. Set in place with the top Angle Set Screw and secure with a washer and nut. Do not allow the speaker to tilt forward more than 15° during this operation.

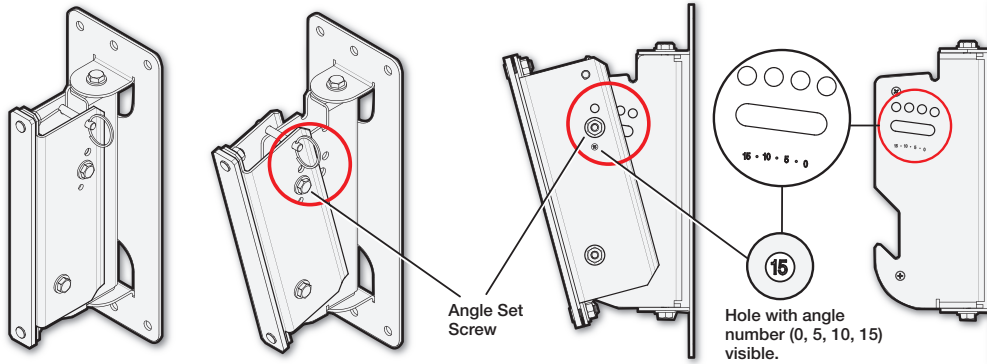

Figure 17. Setting Tilt Angle with Angle Set Screw

If the speaker is to be set at an angle other than one of the presets, insert the Angle Set Screw through the angle adjustment slot (see figure 17). Position speaker at required angle and tighten Angle Set Screw to 85-90 in-lb (7.0 - 7.5 ft-lb) (9.6 - 10.1 N-m) to secure.

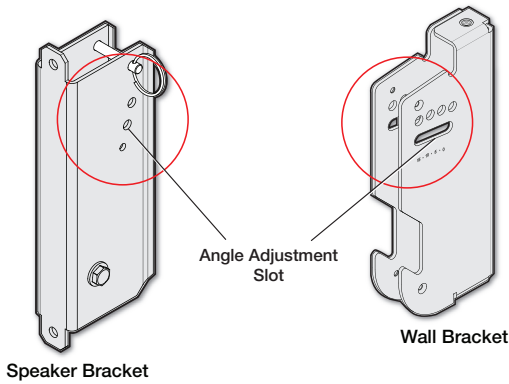

Figure 18. Angle Adjustment Slot

Adjusting Pan Angle

Set the speaker pan angle and tighten Pan Angle Set Screws (top and bottom, see diagram on the right).

The speaker can be adjusted up to 74° to the left or right when the tilt angle is set to 0°.

Tighten Pan Angle Set Screws to 35-40 in-lb (2.9- 3.3 ft-lb) (3.9 – 4.5 N-m).

NOTE: There may be limitations to the maximum pan angle that can be set, based on available space and amount of tilt. See the table below for more details.

SMK PT CA Maximum Pan Angle			
0° Down-Tilt	5° Down-Tilt	10° Down-Tilt	15° Down-Tilt
± 74°	± 69°	± 61°	± 51°

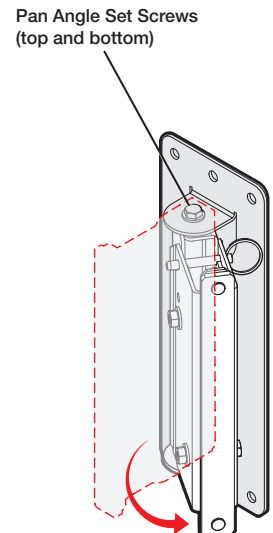

Secondary Tie-off

The Secondary Tie-off option secures the speaker to a suitable anchor point on the wall or ceiling. It is included for regions that require it.

1. Slide the Secondary Tie-off assembly into the top end of the T-slot.
2. Tighten nut to secure the assembly in place.
3. Attach tie cable to building structure.

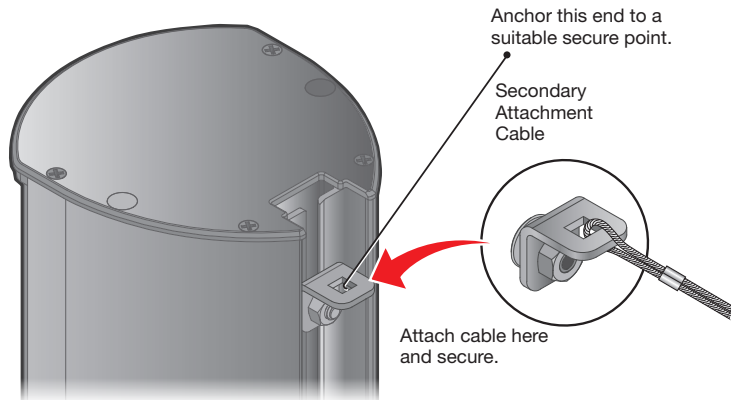
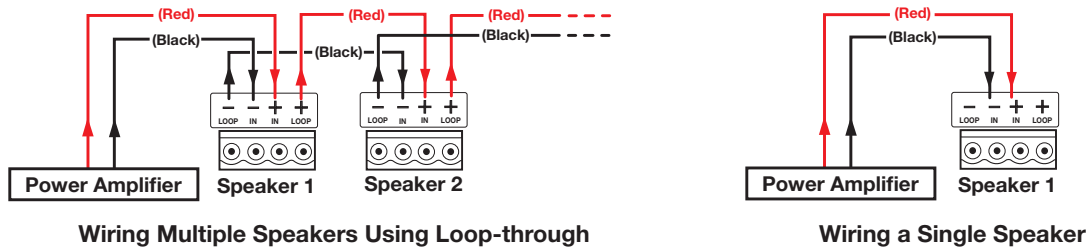

Figure 19. Securing the Secondary Tie-off

Speaker Wiring Options

Use one of the following two methods to attach the speaker wires to the captive screw connector (as per configuration).



Wiring Multiple Speakers Using Loop-through

Wiring a Single Speaker

When a chain of speakers is wired this way, disconnecting one speaker removes power from all downstream speakers.

Figure 20. Speaker Wiring Options

NOTES:

- When connecting multiple speakers in 6.5-ohm mode, be sure that the combined rated impedance does not equal a value less than the minimum rated impedance of the amplifier.
- When connecting in 70V/100V mode, be sure the combined wattage of the taps of all speakers is less than the rated wattage of the amplifier output.
- The connector can support wire gauges up to 12 AWG.

Mounting Template Diagram

NOTE: This image is NOT to scale.

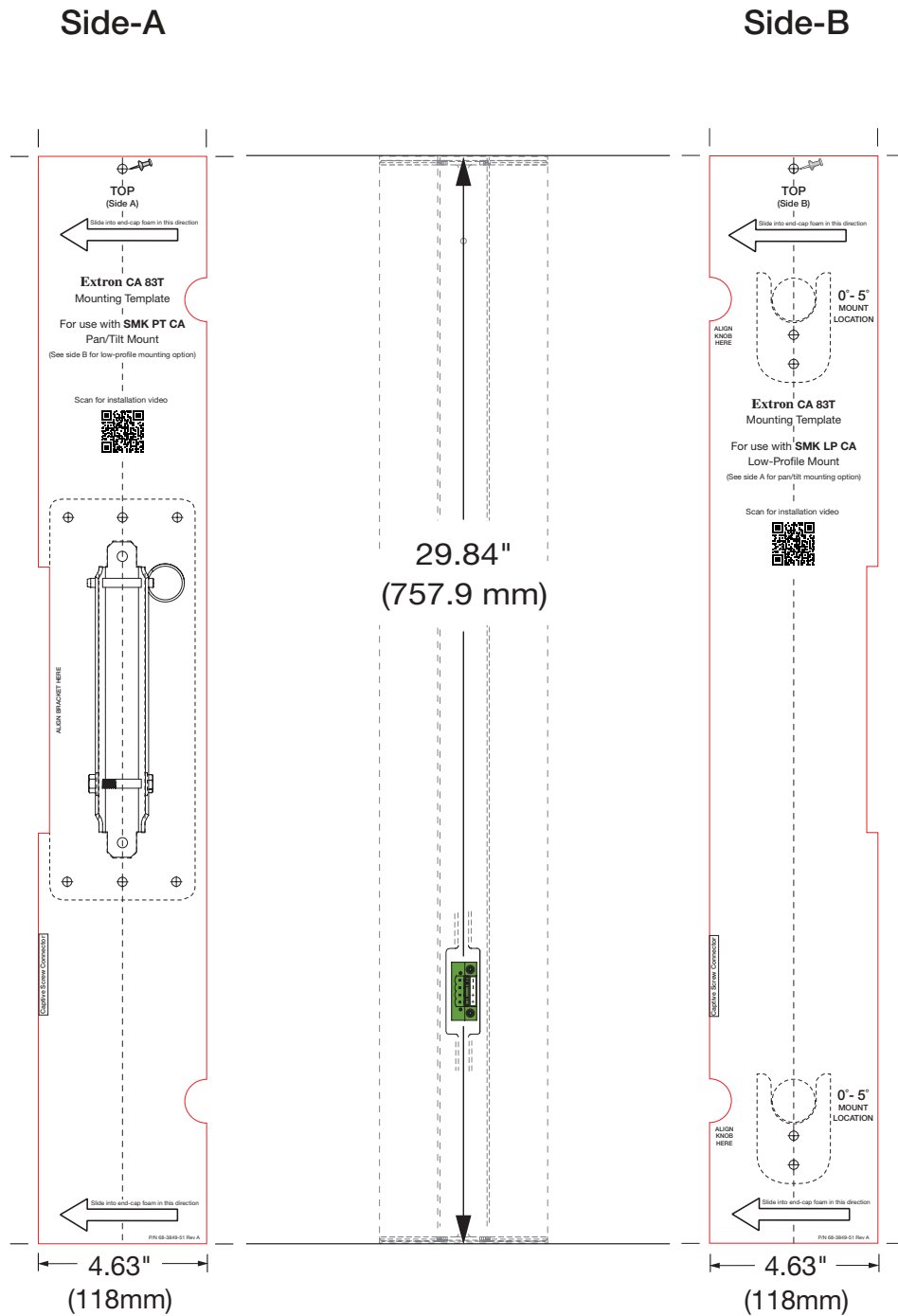

Figure 21. CA 83T Speaker Mounting Template (NOT to scale)

For information on safety guidelines, regulatory compliances, EMI/EMF compatibility, accessibility, and related topics, see the [Extron Safety and Regulatory Compliance Guide](#) on the Extron website.