

## Setup Guide

**IMPORTANT:**  
Refer to [www.extron.com](http://www.extron.com) for the complete user manual and installation instructions before connecting the product to the power source.



**Fiber Matrix 6400**  
Configurable Fiber Optic Digital Matrix Switchers

<b>Extron USA - West</b> Headquarters +800.633.9876 Inside USA / Canada Only +1.714.491.1500 +1.714.491.1517 FAX	<b>Extron USA - East</b> +800.633.9876 Inside USA / Canada Only +1.919.863.1794 +1.919.863.1797 FAX	<b>Extron Europe</b> +800.3987.6673 Inside Europe Only +31.33.453.4040 +31.33.453.4050 FAX	<b>Extron Asia</b> +800.7339.8766 Inside Asia Only +65.6383.4400 +65.6383.4664 FAX	<b>Extron Japan</b> +81.3.3511.7655 +81.3.3511.7656 FAX	<b>Extron China</b> +400.883.1568 Inside China Only +86.21.3760.1568 +86.21.3760.1566 FAX	<b>Extron Middle East</b> +971.4.2991800 +971.4.2991880 FAX
---	---	--	--	---	---	---

# Precautions

## Safety Instructions • English



This symbol is intended to alert the user of important operating and maintenance (servicing) instructions in the literature provided with the equipment.



This symbol is intended to alert the user of the presence of uninsulated dangerous voltage within the product's enclosure that may present a risk of electric shock.

## Caution

**Read Instructions** • Read and understand all safety and operating instructions before using the equipment.

**Retain Instructions** • The safety instructions should be kept for future reference.

**Follow Warnings** • Follow all warnings and instructions marked on the equipment or in the user information.

**Avoid Attachments** • Do not use tools or attachments that are not recommended by the equipment manufacturer because they may be hazardous.

## Consignes de Sécurité • Français



Ce symbole sert à avertir l'utilisateur que la documentation fournie avec le matériel contient des instructions importantes concernant l'exploitation et la maintenance (réparation).



Ce symbole sert à avertir l'utilisateur de la présence dans le boîtier de l'appareil de tensions dangereuses non isolées posant des risques d'électrocution.

## Attention

**Lire les instructions** • Prendre connaissance de toutes les consignes de sécurité et d'exploitation avant d'utiliser le matériel.

**Conservier les instructions** • Ranger les consignes de sécurité afin de pouvoir les consulter à l'avenir.

**Respecter les avertissements** • Observer tous les avertissements et consignes marqués sur le matériel ou présentés dans la documentation utilisateur.

**Éviter les pièces de fixation** • Ne pas utiliser de pièces de fixation ni d'outils non recommandés par le fabricant du matériel car cela risquerait de poser certains dangers.

## Sicherheitsanleitungen • Deutsch



Dieses Symbol soll dem Benutzer in der im Lieferumfang enthaltenen Dokumentation besonders wichtige Hinweise zur Bedienung und Wartung (Instandhaltung) geben.



Dieses Symbol soll den Benutzer darauf aufmerksam machen, daß im Inneren des Gehäuses dieses Produktes gefährliche Spannungen, die nicht isoliert sind und die einen elektrischen Schock verursachen können, herrschen.

## Achtung

**Lesen der Anleitungen** • Bevor Sie das Gerät zum ersten Mal verwenden, sollten Sie alle Sicherheits- und Bedienungsanleitungen genau durchlesen und verstehen.

**Aufbewahren der Anleitungen** • Die Hinweise zur elektrischen Sicherheit des Produktes sollten Sie aufbewahren, damit Sie im Bedarfsfall darauf zurückgreifen können.

**Befolgen der Warnhinweise** • Befolgen Sie alle Warnhinweise und Anleitungen auf dem Gerät oder in der Benutzerdokumentation.

**Keine Zusatzgeräte** • Verwenden Sie keine Werkzeuge oder Zusatzgeräte, die nicht ausdrücklich vom Hersteller empfohlen wurden, da diese eine Gefahrenquelle darstellen können.

## Instrucciones de seguridad • Español



Este símbolo se utiliza para advertir al usuario sobre instrucciones importantes de operación y mantenimiento (o cambio de partes) que se desean destacar en el contenido de la documentación suministrada con los equipos.



Este símbolo se utiliza para advertir al usuario sobre la presencia de elementos con voltaje peligroso sin protección aislante, que puedan encontrarse dentro de la caja o alojamiento del producto, y que puedan representar riesgo de electrocución.

## Precaución

**Leer las instrucciones** • Leer y analizar todas las instrucciones de operación y seguridad, antes de usar el equipo.

**Conservar las instrucciones** • Conservar las instrucciones de seguridad para futura consulta.

**Obedecer las advertencias** • Todas las advertencias e instrucciones marcadas en el equipo o en la documentación del usuario, deben ser obedecidas.

**Evitar el uso de accesorios** • No usar herramientas o accesorios que no sean específicamente recomendados por el fabricante, ya que podrían implicar riesgos.

## Warning

**Power sources** • This equipment should be operated only from the power source indicated on the product. This equipment is intended to be used with a main power system with a grounded (neutral) conductor. The third (grounding) pin is a safety feature, do not attempt to bypass or disable it.

**Power disconnection** • To remove power from the equipment safely, remove all power cords from the rear of the equipment, or the desktop power module (if detachable), or from the power source receptacle (wall plug).

**Power cord protection** • Power cords should be routed so that they are not likely to be stepped on or pinched by items placed upon or against them.

**Servicing** • Refer all servicing to qualified service personnel. There are no user-serviceable parts inside. To prevent the risk of shock, do not attempt to service this equipment yourself because opening or removing covers may expose you to dangerous voltage or other hazards.

**Slots and openings** • If the equipment has slots or holes in the enclosure, these are provided to prevent overheating of sensitive components inside. These openings must never be blocked by other objects.

**Lithium battery** • There is a danger of explosion if battery is incorrectly replaced. Replace it only with the same or equivalent type recommended by the manufacturer. Dispose of used batteries according to the manufacturer's instructions.

## Avertissement

**Alimentations** • Ne faire fonctionner ce matériel qu'avec la source d'alimentation indiquée sur l'appareil. Ce matériel doit être utilisé avec une alimentation principale comportant un fil de terre (neutre). Le troisième contact (de mise à la terre) constitue un dispositif de sécurité : n'essayez pas de le contourner ni de le désactiver.

**Déconnexion de l'alimentation** • Pour mettre le matériel hors tension sans danger, déconnectez tous les cordons d'alimentation de l'arrière de l'appareil ou du module d'alimentation de bureau (s'il est amovible) ou encore de la prise secteur.

**Protection du cordon d'alimentation** • Acheminer les cordons d'alimentation de manière à ce que personne ne risque de marcher dessus et à ce qu'ils ne soient pas écrasés ou pincés par des objets.

**Réparation-maintenance** • Faire exécuter toutes les interventions de réparation-maintenance par un technicien qualifié. Aucun des éléments internes ne peut être réparé par l'utilisateur. Afin d'éviter tout danger d'électrocution, l'utilisateur ne doit pas essayer de procéder lui-même à ces opérations car l'ouverture ou le retrait des couvercles risquent de l'exposer à de hautes tensions et autres dangers.

**Fentes et orifices** • Si le boîtier de l'appareil comporte des fentes ou des orifices, ceux-ci servent à empêcher les composants internes sensibles de surchauffer. Ces ouvertures ne doivent jamais être bloquées par des objets.

**Lithium Batterie** • Il a danger d'explosion s'il y a remplacement incorrect de la batterie. Remplacer uniquement avec une batterie du même type ou d'un type équivalent recommandé par le constructeur. Mettre au rebut les batteries usagées conformément aux instructions du fabricant.

## Vorsicht

**Stromquellen** • Dieses Gerät sollte nur über die auf dem Produkt angegebene Stromquelle betrieben werden. Dieses Gerät wurde für eine Verwendung mit einer Hauptstromleitung mit einem geerdeten (neutralen) Leiter konzipiert. Der dritte Kontakt ist für einen Erdschluss, und stellt eine Sicherheitsfunktion dar. Diese sollte nicht umgangen oder außer Betrieb gesetzt werden.

**Stromunterbrechung** • Um das Gerät auf sichere Weise vom Netz zu trennen, sollten Sie alle Netzkabel aus der Rückseite des Gerätes, aus der externen Stromversorgung (falls dies möglich ist) oder aus der Wandsteckdose ziehen.

**Schutz des Netzkabels** • Netzkabel sollten stets so verlegt werden, daß sie nicht im Weg liegen und niemand darauf treten kann oder unmittelbar dagegen gestellt werden können.

**Wartung** • Alle Wartungsmaßnahmen sollten nur von qualifiziertem Servicepersonal durchgeführt werden. Die internen Komponenten des Gerätes sind wartungsfrei. Zur Vermeidung eines elektrischen Schocks versuchen Sie in keinem Fall, dieses Gerät selbst öffnen, da beim Entfernen der Abdeckungen die Gefahr eines elektrischen Schlags und/oder andere Gefahren bestehen.

**Schlitze und Öffnungen** • Wenn das Gerät Schlitze oder Löcher im Gehäuse aufweist, dienen diese zur Vermeidung einer Überhitzung der empfindlichen Teile im Inneren. Diese Öffnungen dürfen niemals von anderen Objekten blockiert werden.

**Litium-Batterie** • Explosionsgefahr, falls die Batterie nicht richtig ersetzt wird. Ersetzen Sie verbrauchte Batterien nur durch den gleichen oder einen vergleichbaren Batterietyp, der auch vom Hersteller empfohlen wird. Entsorgen Sie verbrauchte Batterien bitte gemäß den Herstelleranweisungen.

## Advertencia

**Alimentación eléctrica** • Este equipo debe conectarse únicamente a la fuente/tipo de alimentación eléctrica indicada en el mismo. La alimentación eléctrica de este equipo debe provenir de un sistema de distribución general con conductor neutro a tierra. La tercera pata (puesta a tierra) es una medida de seguridad, no puentearla ni eliminarla.

**Desconexión de alimentación eléctrica** • Para desconectar con seguridad la acometida de alimentación eléctrica al equipo, desenchufar todos los cables de alimentación en el panel trasero del equipo, o desenchufar el módulo de alimentación (si fuera independiente), o desenchufar el cable del receptáculo de la pared.

**Protección del cables de alimentación** • Los cables de alimentación eléctrica se deben instalar en lugares donde no sean pisados ni apretados por objetos que se puedan apoyar sobre ellos.

**Reparaciones/mantenimiento** • Solicitar siempre los servicios técnicos de personal calificado. En el interior no hay partes a las que el usuario deba acceder. Para evitar riesgo de electrocución, no intentar personalmente la reparación/mantenimiento de este equipo, ya que al abrir o extraer las tapas puede quedar expuesto a voltajes peligrosos u otros riesgos.

**Ranuras y aberturas** • Si el equipo posee ranuras o orificios en su caja/alojamiento, es para evitar el sobrecalentamiento de componentes internos sensibles. Estas aberturas nunca se deben obstruir con otros objetos.

**Batería de litio** • Existe riesgo de explosión si esta batería se coloca en la posición incorrecta. Cambiar esta batería únicamente con el mismo tipo (o su equivalente) recomendado por el fabricante. Desachar las baterías usadas siguiendo las instrucciones del fabricante.

# Extron's Warranty

Extron Electronics warrants this product against defects in materials and workmanship for a period of three years from the date of purchase. In the event of malfunction during the warranty period attributable directly to faulty workmanship and/or materials, Extron Electronics will, at its option, repair or replace said products or components, to whatever extent it shall deem necessary to restore said product to proper operating condition, provided that it is returned within the warranty period, with proof of purchase and description of malfunction to:

**USA, Canada, South America, and Central America:**

Extron Electronics  
1001 East Ball Road  
Anaheim, CA 92805, USA

## Asia:

Extron Electronics, Asia  
135 Joo Seng Road, #04-01  
PM Industrial Bldg.  
Singapore 368363

**Europe, Africa, and the Middle East:**

Extron Electronics, Europe  
Beeldschermweg 6C  
3821 AH Amersfoort  
The Netherlands

## Japan:

Extron Electronics, Japan  
Kyodo Building  
16 Ichibancho  
Chiyoda-ku, Tokyo 102-0082  
Japan

This Limited Warranty does not apply if the fault has been caused by misuse, improper handling care, electrical or mechanical abuse, abnormal operating conditions or non-Extron authorized modification to the product.

*If it has been determined that the product is defective, please call Extron and ask for an Applications Engineer at (714) 491-1500 (USA), 31.33.453.4040 (Europe), 65.6383.4400 (Asia), or 81.3.3511.7655 (Japan) to receive an RA# (Return Authorization number). This will begin the repair process as quickly as possible.*

Units must be returned insured, with shipping charges prepaid. If not insured, you assume the risk of loss or damage during shipment. Returned units must include the serial number and a description of the problem, as well as the name of the person to contact in case there are any questions.

Extron Electronics makes no further warranties either expressed or implied with respect to the product and its quality, performance, merchantability, or fitness for any particular use. In no event will Extron Electronics be liable for direct, indirect, or consequential damages resulting from any defect in this product even if Extron Electronics has been advised of such damage.

Please note that laws vary from state to state and country to country, and that some provisions of this warranty may not apply to you.

---

## 安全须知 • 中文



这个符号提示用户该设备用户手册中有重要的操作和维护说明。



这个符号警告用户该设备机壳内有暴露的危险电压，有触电危险。

### 注意

**阅读说明书** • 用户使用该设备前必须阅读并理解所有安全和使用说明。

**保存说明书** • 用户应保存安全说明书以备将来使用。

**遵守警告** • 用户应遵守产品和用户指南上的所有安全和操作说明。

**避免追加** • 不要使用该产品厂商没有推荐的工具或追加设备，以避免危险。

### 警告

**电源** • 该设备只能使用产品上标明的电源。设备必须使用有地线的供电系统供电。第三条线（地线）是安全设施，不能不用或跳过。

**拔掉电源** • 为安全地从设备拔掉电源，请拔掉所有设备后或桌面电源的电源线，或任何接到市电系统的电源线。

**电源线保护** • 妥善布线，避免被踩踏，或重物挤压。

**维护** • 所有维修必须由认证的维修人员进行。设备内部没有用户可以更换的零件。为避免出现触电危险不要自己试图打开设备盖子维修该设备。

**通风孔** • 有些设备机壳上有通风槽或孔，它们是用来防止机内敏感元件过热。不要用任何东西挡住通风孔。

**锂电池** • 不正确的更换电池会有爆炸的危险。必须使用与厂家推荐的相同或相近型号的电池。按照生产厂的建议处理废弃电池。

## FCC Class A Notice

This equipment has been tested and found to comply with the limits for a Class A digital device, pursuant to part 15 of the FCC Rules. Front Panel Operation is subject to the following two conditions: (1) this device may not cause harmful interference, and (2) this device must accept any interference received, including interference that may cause undesired operation. The Class A limits are designed to provide reasonable protection against harmful interference when the equipment is operated in a commercial environment. This equipment generates, uses, and can radiate radio frequency energy and, if not installed and used in accordance with the instruction manual, may cause harmful interference to radio communications. Front Panel Operation of this equipment in a residential area is likely to cause harmful interference, in which case the user will be required to correct the interference at his own expense.

### NOTE

*This unit was tested with shielded cables on the peripheral devices. Shielded cables must be used with the unit to ensure compliance with FCC emissions limits.*

# Table of Contents

---

<b>Chapter One • Introduction</b> .....	1-1
About this Manual .....	1-2
About the Fiber Matrix 6400 Switchers .....	1-2
Configurability and transmission modes .....	1-4
<b>Chapter Two • Installation</b> .....	2-1
Rear Panel .....	2-2
A note on I/O boards .....	2-2
Making connections.....	2-4
Front Panel.....	2-6
<b>Chapter Three • Front Panel Operation</b> .....	3-1
Creating a Tie.....	3-2
Viewing Ties (and Muting Outputs).....	3-2
Saving or Recalling a Preset.....	3-3
Locking Out the Front Panel (Executive Mode).....	3-3
<b>Chapter Four • Remote Control</b> .....	4-1
Selected SIS Commands.....	4-2
Establishing a network (Ethernet) connection .....	4-2
Connection timeouts .....	4-2
Number of connections.....	4-3
Verbose mode.....	4-3
Host-to-switcher instructions .....	4-3
Installing and Starting the Control Program .....	4-8
Installing the program .....	4-8
Starting the program.....	4-9
Accessing the HTML Pages .....	4-11
Configuring for Network Communication .....	4-11
Loading the start-up page.....	4-13
<b>Chapter Five • Maintenance and Modifications</b> .....	5-1
Removing and Installing an I/O Board or Blank Panel..	5-2
Removing and Installing a Power Supply Module .....	5-4



# 1 Chapter One

## Introduction

About this Manual

About the Fiber Matrix 6400 Switchers

*All trademarks mentioned in this manual are the properties of their respective owners.*

# Introduction

**WARNING** The Fiber Matrix 6400's fiber optic I/O boards output continuous invisible light, which may be harmful and dangerous to the eyes; use with caution.

- Do not look into the rear panel fiber optic cable connectors or into the fiber optic cables themselves.
- Plug the attached dust caps into the optical transceivers when the fiber optic cable is unplugged.

**NOTE** For more information on any subject in this guide, refer to the Fiber Matrix 6400 Switcher User's Manual, available on the Extron DVD or at [www.extron.com](http://www.extron.com).

## About this Manual

This setup guide helps you to easily and quickly set up and configure your Extron Fiber Matrix 6400 Switcher. Step by step instructions show you how to:

- Connect the hardware
- Perform basic operations
- Use both the front panel controls and selected Simple Instruction Set (SIS™) commands
- Load and start up the Windows®-based Matrix Switchers Control Program
- Connect to the built-in HTML pages, which you can use to operate the switcher
- Replace the I/O boards and power supplies

## About the Fiber Matrix 6400 Switchers

The Fiber Matrix 6400 (figure 1-1) is a configurable matrix switcher that distributes optical and electrical signals. Fiber optic I/O boards route signals that are compatible with all Extron FOX 500 fiber optic product lines. SDI/HD-SDI I/O boards route serial digital interface (SDI) and high definition serial digital interface (HD-SDI) signals. The matrix switcher routes any input signal to any combination of outputs. An optical input can be tied to optical and/or SDI/HD-SDI outputs and an SDI/HD-SDI input can be tied to SDI/HD-SDI and/or optical outputs. The matrix switcher can route multiple input/output configurations simultaneously.

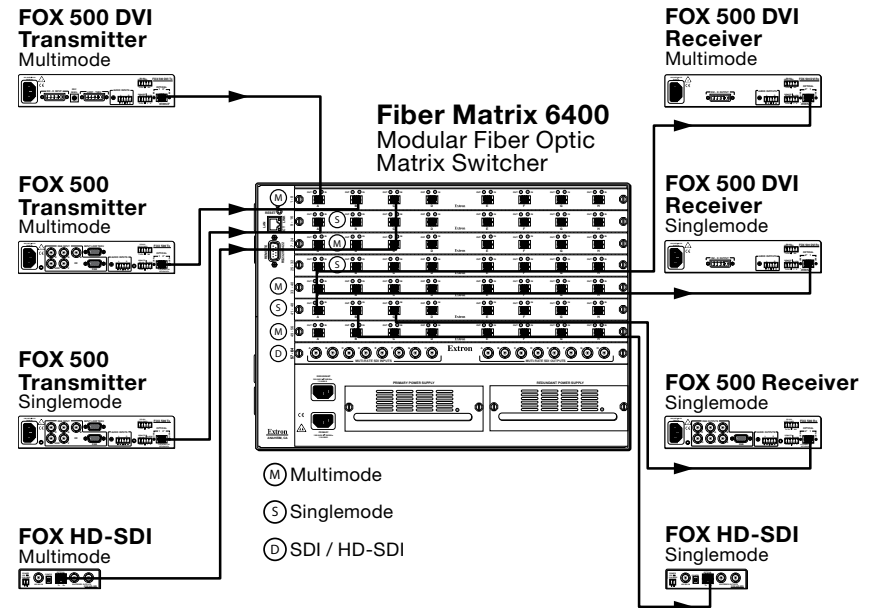

**Figure 1-1 — Typical Fiber Matrix 6400 application**

The Extron proprietary fiber optic signal, generated by FOX 500 transmitters, can include video, stereo audio, and transmitter-to-receiver RS-232 serial communication. The video component of the signal can be RGB video, Digital Visual Interface (DVI) video, SDI/HD-SDI video, or low resolution video, depending on the transmitter and receiver.

The matrix switcher can be remotely controlled via its Ethernet LAN port or either of two serial ports using either Windows-based Extron Matrix Switchers Control Program or the SIS.

The switcher has two internal, hot-swappable 100 VAC to 240 VAC, 50-60 Hz, 180-watt power supplies that provide worldwide power compatibility and reliability.

**NOTE** Compatible optical signals are digital signals from 270 Mbs through 4.25 Gbps that are sent and received via fiber optic small form factor pluggable (SFP) modules. The Fiber Matrix 6400 supports all compatible optical signals, whether transmitted or received by an Extron FOX system component or not.

**NOTE** The FOX 500 transmitter-to-receiver communications, including the serial link, occupy one matrix switcher input and output.

This matrix switcher also supports the FOX 500 return (receiver-to-transmitter) serial communications, but returning this signal stream to the transmitter occupies a separate matrix switcher input and output.

### Configurability and transmission modes

The Fiber Matrix is assembled from individual input/output (I/O) boards. The switcher can include up to eight I/O boards, each of which supports eight inputs by eight outputs. The three types of I/O boards are:

- **Singlemode fiber optic 8x8 I/O board**, equipped with removable fiber optic transceiver modules
- **Multimode fiber optic 8x8 I/O board**, equipped with removable fiber optic transceiver modules
- **SDI/HD-SDI 8x8 I/O board**, equipped with permanent BNC connectors

**NOTE** As listed above, two versions of the fiber optic I/O boards are documented in this manual. They are categorized by the type of fiber optic cable, multimode or singlemode, which defines the effective range of transmission:

- **Singlemode** — Very long distance, up to 30 km (18.75 miles)
- **Multimode** — Long distance, up to 150 m (450 feet)

By adding or removing I/O boards, you can expand and contract the Fiber Matrix from an 8-input by 8-output matrix to a 64-input by 64-output matrix.

**NOTE** On a fiber optic I/O board as delivered from Extron, all transceiver modules are configured the same: either all multimode or all singlemode. You **can** mix multimode and singlemode fiber optic I/O boards in a Fiber Matrix switcher, but you must ensure that you connect the proper transmission mode fiber cables to the board.



# 2 Chapter Two

## Installation

Rear Panel

Front Panel

# Installation

## Rear Panel

### A note on I/O boards

See figure 2-1. Each I/O board is identified by the input and output numbers supported by the board position. The transceiver modules on the I/O boards are identified as A through H.

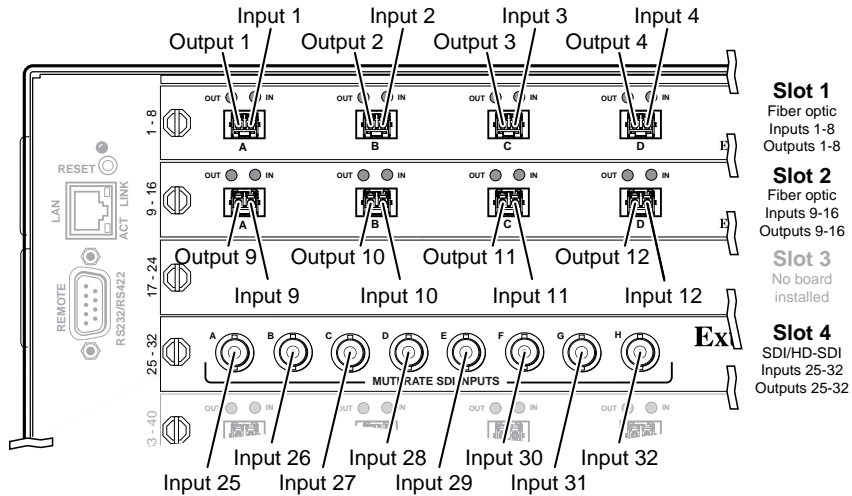
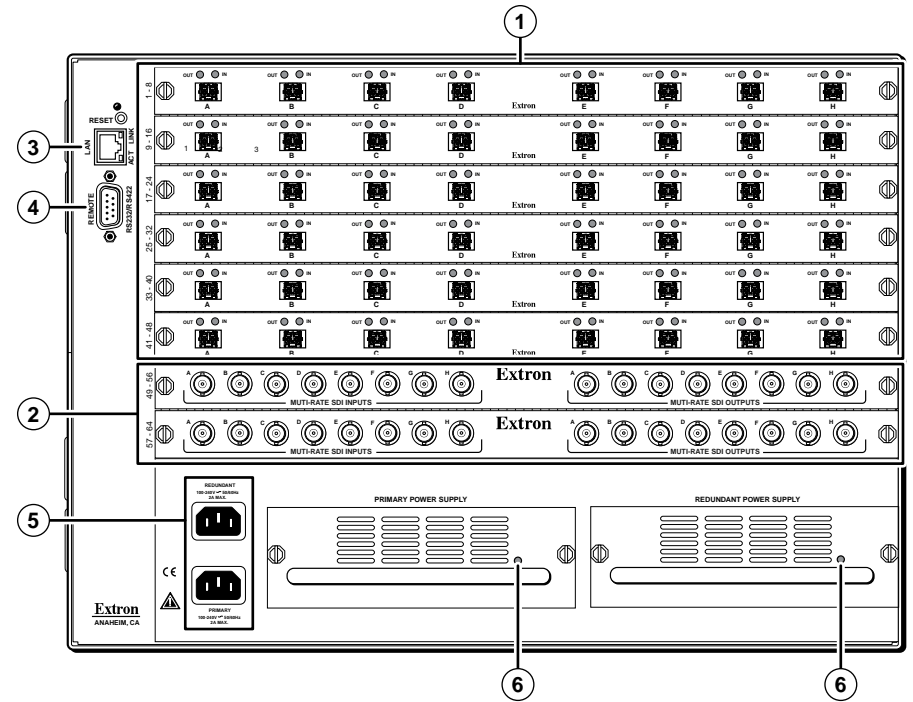

**Figure 2-1 — Arrangement of inputs and outputs on the I/O boards**

The board position designators correspond to the input and output numbers served by that position (1 - 8, 9 - 16, and so on).

The location designators, A through H on each board correspond to the transceiver modules, numbered from left to right, each of which includes an input and an output.

See figure 2-1. The input and output numbers supported by the I/O board in location 9 - 16 are as follows: A = 9, B = 10, C = 11, D = 12, E = 13, F = 14, G = 15, and H = 16.)



**Figure 2-2 — Fiber Matrix 6400 Switcher rear panel**

- ① Fiber optic connectors and LEDs — See page 2-4.
- ② SDI/HDI-SDI BNC connectors — See page 2-5.
- ③ Ethernet connection (LAN connector) — See page 2-5.
- ④ Remote port — See page 2-5.
- ⑤ Power connectors — See page 2-5.
- ⑥ Power indicator LEDs — See page 2-5.

## Making connections

### ① Fiber optic connectors and LEDs —

**WARNING** This unit outputs continuous invisible light, which may be harmful and dangerous to the eyes; use with caution. For additional safety, plug the attached dust caps into the optical transceivers when the fiber optic cable is unplugged.

**NOTE** Ensure that you use the proper fiber cable for your I/O board. Typically, singlemode fiber has a yellow jacket and multimode cable has an orange jacket.

**NOTE** The Fiber Matrix 6400 uses one connector on the block as an input and the second connector on the same block as a separate output.

**1a) Input connector —**  
Connect a fiber optic cable between each Input LC connector and a FOX 500 Tx or any other compatible Extron FOX 500 device.

**NOTE** Or, for the FOX 500 serial return, (receiver-to-transmitter) function, connect the free end to the Optical 2 connector on a FOX 500 Rx receiver.

**Input LED —** When lit, the link is active (light is received).

**1b) Output connector —**  
Connect a fiber optic cable between each output LC connector and a FOX 500 Rx or any other compatible Extron FOX 500 device.

**NOTE** Or, for the FOX 500 serial return, (receiver-to-transmitter) function, connect the free end to the Optical 2 connector on a FOX 500 Tx transmitter.

**Output LED —** This LED is always lit.

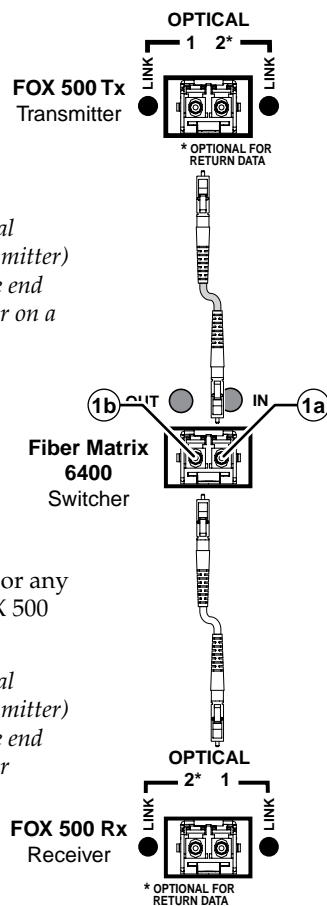

### ② BNC connectors —

**2a) Multi-rate SDI Input connectors —** Connect HD-SDI, SDI, or 3G-SDI video inputs to these BNC connectors.

**2b) Multi-rate SDI Output connectors —** Connect digital displays to these BNC connectors.

### ③ Ethernet port —

If desired, connect a network WAN or LAN hub, a control system, or a computer to the Ethernet RJ-45 port.

**Network connection —** Wire as a patch (straight) cable.

**Computer or control system connection —** Wire the interface cable as a crossover cable.

**NOTE** The factory default IP address is 192.168.254.254.

### ④ Remote port —

If desired, connect a control system or computer to the rear panel Remote RS-232/RS-422 port.

Pin	RS-232	Function	RS-422	Function
1	—	Not used	—	Not used
2	TX	Transmit	TX-	Transmit (-)
3	RX	Receive	RX-	Receive (-)
4	—	Not used	—	Not used
5	Gnd	Ground	Gnd	Ground
6	—	Not used	—	Not used
7	—	Not used	RX+	Receive (+)
8	—	Not used	TX+	Transmit (+)
9	—	Not used	—	Not used

**Figure 2-6 — Audio output connector wiring**

### ⑤ Power connector —

Plug the switcher into two grounded AC sources.

**NOTE** For reliability, connect the Redundant power cord to either an uninterruptible power source or to a power source that is completely independent from the primary power source.

### ⑥ Primary and Redundant power supply indicator LEDs —

**Green —** Indicates that the associated power supply is operating within normal tolerances.

**Red —** Indicates that the associated power supply is operating outside the normal tolerances or has failed. See chapter 5, "Maintenance and Modifications" to replace the power supply.

### Front Panel

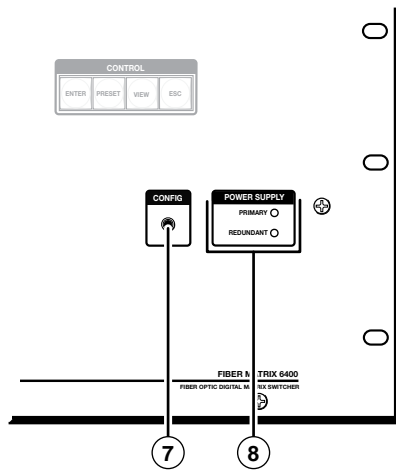

**Figure 2-7 — Front panel configuration port**

- ⑦ **Configuration port** — If desired, connect a control system or computer to the front panel Configuration (RS-232) port. Use an optional 9-pin D to 2.5 mm mini jack TRS RS-232 cable, part #70-335-01.
- ⑧ **Primary and Redundant Power Supply LEDs** —
  - Green** — Indicates that the associated power supply is operating within normal tolerances.
  - Red** — Indicates that the associated power supply is operating outside the normal tolerances or has failed. See chapter 4, “Maintenance and Modifications”, to replace the power supply.



## Fiber Matrix 6400 Switcher

# Chapter Three

## Front Panel Operation

Creating a Tie

Viewing Ties (and Muting Outputs)

Saving or Recalling a Preset

Locking Out the Front Panel (Executive Mode)

## Front Panel Operation

### Creating a Tie

1. Press and release the Esc button to clear any input button, output button, or control button indicators that may be lit.
2. Press and release the desired input button.

The button lights to indicate the selection.



3. Press and release the desired output button(s).

The output buttons blink to indicate the potential ties.



The Enter button blinks to indicate the need to confirm the change.

4. Press and release the Enter button. All button indicators turn off.

### Viewing Ties (and Muting Outputs)

1. Press the View button. Output buttons light for outputs that have no ties established.

**NOTE** If an output button blinks, that output is muted. To toggle mute on and off, press and hold the output button for 2 seconds.

2. Press an input button. The buttons for all tied outputs light.
3. Press an output button. The buttons for the tied input and all tied outputs light.
4. Press the View button. All input and output buttons return to an unlit state.

### Saving or Recalling a Preset

1. Save a preset — Press and hold the Preset button until it flashes.

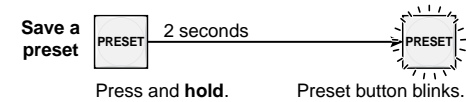

- Recall a preset — Press and release the Preset button.

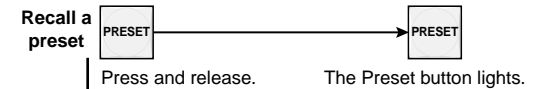

All input and output buttons with assigned presets light red. When a preset is saved, the configuration data at assigned preset locations will be overwritten.



2. Press and release the desired input or output button.

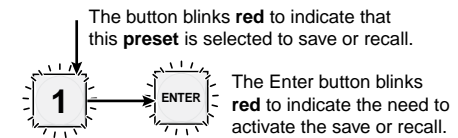

3. Press and release the Enter button.

### Locking Out the Front Panel (Executive Mode)

To toggle the lock on and off, simultaneously press and hold the Enter button and the Esc button for approximately 2 seconds.

Press and hold the Enter and Esc buttons simultaneously to toggle executive mode on or off.

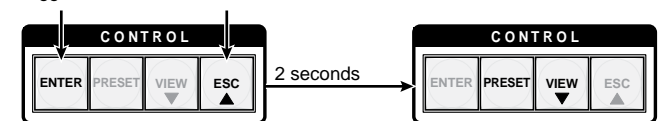

The Preset and View buttons blink twice to indicate the mode change. Release the buttons.



# Chapter Four

## **Remote Control**

Selected SIS Commands

Installing and Starting the Control Program

Accessing the HTML Pages

## Selected SIS Commands

The switchers have Simple Instruction Set (SIS) commands that you can use for operation and configuration. You can run these commands from a PC connected to either of the switcher's serial ports or the Ethernet port. See ③, ④, and ⑦, on pages 2-5 and 2-6, for connection information.

### Establishing a network (Ethernet) connection

**NOTE** *If you connect to the switcher via the LAN port, and it is the first time you have done so, you may change the controller's default settings (IP address, subnet mask, and [optional] administrator name and password). See "Configuring for Network Communication" for details.*

Establish a network connection as follows:

1. Open a TCP socket to port 23 using the switcher's IP address.

**NOTE** *The factory default IP address is 192.168.254.254.*

The switcher responds with a copyright message including the date, the name of the product, the firmware version, the part number, and the current date/time.

**NOTE** *If the switcher is not password-protected, the device is now ready to accept SIS commands.*

*If the switcher is password-protected, a password prompt appears.*

2. If the switcher is password-protected, enter the appropriate password.

If the password is accepted, the switcher responds with *Login User* or *Login Administrator*.

If the password is not accepted, the *Password* prompt reappears.

### Connection timeouts

The Ethernet link times out and disconnects after a designated period of no communication. By default, this timeout value is set to 5 minutes, but the value can be changed. See the *Configure port timeout* SIS commands on page 4-7.

**NOTE** *Extron recommends leaving the default timeout at 5 minutes and periodically issuing the Query (Q) command to keep the connection active or disconnecting the socket and reopening the connection when necessary.*

### Number of connections

A switcher can have up to 200 simultaneous TCP connections, including all HTTP sockets and Telnet connections. When the connection limit is reached, the switcher accepts no new connections until some have been closed. No error message or indication is given that the connection limit has been reached. To maximize performance of your switcher, the number of connections should stay low and unnecessary open sockets should be closed.

### Verbose mode

Telnet connections to a switcher can be used to monitor for changes that occur on the switcher, such as front panel operations and SIS commands from other Telnet sockets or a serial port. For a Telnet session to receive change notices from the switcher, the Telnet session must be in verbose mode 3. See the *Set verbose mode* command on page 4-7. In verbose mode 3, the Telnet socket reports changes in messages that resemble SIS command responses.

### Host-to-switcher instructions

The switcher accepts SIS commands through either serial port. SIS commands consist of one or more characters per command field. They do not require any special characters to begin or end the command character sequence. Each switcher response to an SIS command ends with a carriage return and a line feed (CR/LF = ) , which signals the end of the response character string. A string is one or more characters.

**NOTE** *The table that begins on the next page is a partial list of SIS commands. For a complete listing, refer to the Fiber Matrix 6400 Switcher User's Manual.*



Command	ASCII command (host to switcher)	Response (switcher to host)	Additional description
<b>Front panel lock (executive mode)</b>			
Lock all front panel functions	1X	Exe1 ←	Enable Lock mode 1.
Unlock all front panel functions	0X	Exe0 ←	Enable Lock mode 0.
View lock status	X	X5 ←	
<b>Information requests</b>			
Information request	I	V[X6]X[X7]•A[X6]X[X7]•S[X8]X[X8]²...X[X8]² ←	V[X6]X[X7] shows the number of available inputs and outputs for this configuration. A[X6]X[X7] has no meaning for this product. S[X8]X[X8]²...X[X8]² shows the board type installed in each slot.
Request part number	N	60-878-01 ←	
Query controller firmware version	Q	X9 ←	
<i>Example:</i>	Q	1.23 ←	The factory-installed controller firmware version is 1.23 (sample value only).

- NOTE**
- X5 = Lock mode
    - 0 = unlocked
    - 1 = locked
  - X6 = Inputs
    - Total number of inputs for this switcher
  - X7 = Outputs
    - Total number of outputs for this switcher
  - X8 = Board installed
    - 0 = No board installed
    - 1 = 8x8 multimode board
    - 2 = 8x8 singlemode board
    - 3 = SDI/HD-SDI board
    - x = Unknown board or mix of transceivers installed
  - X9 = Firmware version number to second decimal place (x.xx)

Command	ASCII command (host to switcher)	Response (switcher to host)	Additional description
<b>IP setup</b>			
Set IP address	EscX10CI ←	IpiX10 ←	
Read IP address	EscCI ←	X10 ←	
Set subnet mask	EscX10CS ←	IpsX10 ←	
Read subnet mask	EscCS ←	X10 ←	
Set gateway IP address	EscX10CG ←	IpgX10 ←	
Read gateway IP address	EscCG ←	X10 ←	
Set DHCP on or off	EscX11DH ←	IdhX11 ←	
Read DHCP on/off status	EscDH ←	X11 ←	
Set verbose mode	EscX12CV ←	VrbX12 ←	
Read verbose mode	EscCV ←	X12 ←	
Configure current port timeout	Esc0*X13TC ←	Pti0*X13 ←	
Read current port timeout	Esc0TC ←	X13 ←	
Configure global IP port timeout	Esc1*X13TC ←	Pti1*X13 ←	
Read global IP port timeout	Esc1TC ←	X13 ←	

- NOTE**
- X10 = IP address
    - ###.###.###.###
  - X11 = DHCP
    - 0 = 1 off, 1 = on
  - X12 = Verbose mode
    - 0 = clear/none (default for Telnet connection)
    - 1 = verbose mode (default for RS-232/RS-422 connection)
    - 2 = tagged responses for queries
    - 3 = verbose mode and tagged for queries
  - X13 = Port timeout interval
    - 1 (= 10 seconds) - 65000 (default is 30 = 300 seconds = 5 minutes)

## Installing and Starting the Control Program

Another way to operate the switcher is via the Windows®-based Matrix Switchers Control Program. This program is contained on the Extron Software Products DVD (included with the switcher). Run this program on a PC connected to either of the switcher's serial ports or the Ethernet port. See ③, ④, and ⑦, on pages 2-5 and 2-6, for connection information. The program must be installed on a Windows-based computer and cannot be run from the DVD.

**NOTE** For details on operating the program, refer to the Fiber Matrix 6400 Switcher User's Manual, chapter 5, "Matrix Software".

### Installing the program

1. Insert the DVD into the drive. The installation program should start automatically.

The Extron software DVD window appears.



**NOTE** If the installation program does not self-start, run *Launch.exe* from the DVD.

2. Click the **Software** tab.
3. Scroll to the Matrix Switchers program and click **Install**.

• **Matrix Switchers**  
RS-232 Windows  
Control Program.



4. Follow the on-screen instructions. The installation program creates a C:\Program Files\Extron\Matrix\_Switchers directory and an "Extron Electronics\Matrix Switchers" group folder. It installs the following four programs:

- MATRIX Switcher+ Control Program
- MATRIX Switcher+ Help
- Uninstall MATRIX Switcher
- Check for Matrix Updates

### Starting the program

**NOTE** If you connect to the switcher via the LAN port, and it is the first time you have done so, you may change the controller's default settings (IP address, subnet mask, and [optional] administrator name and password). See "Configuring for Network Communication" for details.

1. Click **Start > Programs > Extron Electronics > Matrix Switchers > MATRIX Switcher + Control Pgm.**

The Comm Port Selection window appears.

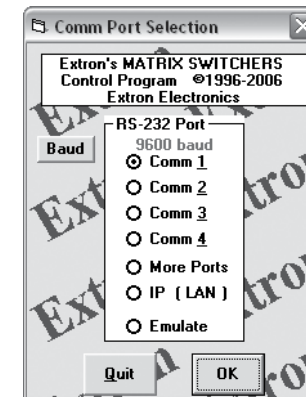

2. Choose the comm (serial) port that is connected to the switcher or **IP [LAN]**.

**NOTE** For a comm port, check the baud rate displayed in the Comm Port Selection window. If you need to change the baud rate, click the **Baud** button and double-click the desired baud rate.

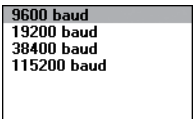

Click **OK**.

If you selected a serial port in step 2, the Matrix Switchers Control Program is ready for operation.

- If you selected IP [LAN] in step 2, the IP Connection window appears.

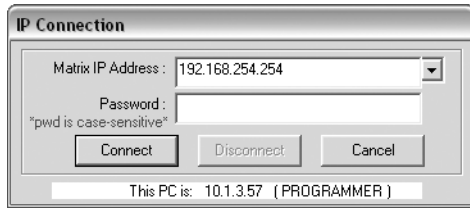

- Examine the Matrix IP Address field, which displays the last Matrix IP address entered.

If necessary, enter the correct IP address in the field.

**NOTE** 192.168.254.254 is the factory-specified default value for this field.

- If the switcher is password-protected, enter the appropriate administrator or user password in the Password field.
- Click **Connect**. The Matrix Switchers Control Program is ready for operation.

## Accessing the HTML Pages

Another way to operate the switcher is via its factory-installed HTML pages, which are always available and cannot be erased or overwritten. The switcher's HTML pages are accessible through its LAN port, connected via a LAN or WAN, using a Web browser such as Microsoft Internet Explorer. See ⑦, on page 2-6, for connection information.

## Configuring for Network Communication

The first time you connect a PC to a switcher via its LAN port, you may need to temporarily change the PC's IP settings in order to communicate with the controller. Then you must change the controller's default settings (IP address, subnet mask, and [optional] administrator name and password) in order to use the unit on an intranet (LAN) or on the Internet. After you have set up the Fiber Matrix 6400 for network communication, you can reset the PC to its original network configuration.

**NOTE** The computer and the switcher must both be connected to the same subnet on a LAN (using a straight-through cable). Alternatively, you can use a crossover Ethernet cable to connect the controller directly to the computer.

Use the ARP command to configure the IP address as follows:

- Obtain a valid IP address for the Fiber Matrix 6400 from the network administrator.
- Obtain the switcher's MAC address (UID #) from the label on its rear panel. The MAC address should have this format: 00-05-A6-xx-xx-xx.
- If the switcher has never been configured and is still set for factory defaults, go to step 4. If not, perform a Mode 4 system reset. For detailed information on reset modes, see "Rear Panel Operations" in the Fiber Matrix 6400 Switcher User's Manual.

**NOTE** The switcher must be configured with the factory default IP address (192.168.254.254) before the ARP command is executed, as described below.

- At the PC, access the MS-DOS® command prompt, then enter the `arp -s` command. Type in the desired new IP address for the unit (obtained in step 1) and the unit's MAC address (from the unit's rear panel). For example: `arp -s 10.13.197.7 00-05-A6-03-69-B0` and then press {Enter}.

After receiving the `arp -s` command, the controller changes to the new address and starts responding to the ping requests, as described in step 5.

**NOTE** You must ping the Fiber Matrix 6400 as shown in step 5 for the IP address change to take place. The response should show the new IP address, as shown in the following figure.

- Execute a ping command by entering "ping" followed by a space and the new IP address at the command prompt. For example:  
`ping 10.13.197.7`

```
C:\>ping 10.13.197.7

Pinging 10.13.197.7 with 32 bytes of data:

Reply from 10.13.197.7: bytes=32 time<10ms TTL=128
Reply from 10.13.197.7: bytes=32 time<10ms TTL=128
Reply from 10.13.197.7: bytes=32 time<10ms TTL=128
Reply from 10.13.197.7: bytes=32 time<10ms TTL=128

Ping statistics for 10.13.197.7:
    Packets: Sent = 4, Received = 4, Lost = 0 (0% loss),
    Approximate round trip times in milli-seconds:
        Minimum = 0ms, Maximum = 0ms, Average = 0ms
```

**NOTE** You can reconnect using either Telnet or a Web browser to verify that the update was successful.

- After verifying that the IP address change was successful, enter and issue the "`arp -d`" command at the DOS prompt. For example:  
`arp -d 10.13.197.7` removes 10.13.197.7 from the ARP table  
or  
`arp -d*` removes all static IP addresses from the ARP table.

## Loading the start-up page

**NOTE** If your Ethernet connection to the matrix switcher is unstable, try turning off the proxy server in your Web browser. In Microsoft Internet Explorer, click **Tools** > **Internet Options** > **Connections** > **LAN Settings**, uncheck the **Use a proxy server...** box, and then click **OK**.

**NOTE** For details on operating the switcher via HTML pages, refer to the Fiber Matrix 6400 Switcher User's Manual, chapter 6, "HTML Operation".

- Start the Web browser program.
- Click in the browser's Address field.
- Enter the Matrix IP address in the browser's Address field.

**NOTE** 192.168.254.254 is the factory-specified default value for this field.

- Press the keyboard Enter key. The switcher checks to see if it is password-protected.

If the switcher is not password-protected, it checks and downloads the HTML start-up page. The switcher is ready for operation via HTML remote control.

If the switcher is password-protected, it downloads the Enter Network Password page.



**NOTE** A User name entry is not required.

- Enter the appropriate administrator or user password in the Password field and click **OK**.
- The switcher downloads the HTML start-up page. The switcher is ready for operation via HTML remote control.



# 5 Chapter Five

## **Maintenance and Modifications**

Removing and Installing an I/O Board or Blank Panel

Removing and installing a Power Supply Module

## Maintenance and Modifications

### Removing and Installing an I/O Board or Blank Panel

**WARNING** The Fiber Matrix 6400 fiber optic I/O boards output continuous invisible light, which may be harmful and dangerous to the eyes; use with caution.

- Do not look into the rear panel fiber optic cable connectors or into the fiber optic cables themselves.
- Plug the attached dust caps into the optical transceivers when the fiber optic cable is unplugged.

**NOTE** As factory configured, the fiber optic I/O boards are configured as either 100 percent singlemode or 100 percent multimode, but you can remove a fiber optic transceiver module (one input and one output) of one transmission mode and replace it with a block of the other transmission mode.

You can mix transmission mode transceiver modules on a fiber optic I/O board, provided that you ensure that each fiber cable and connected devices are the appropriate transmission mode for the transceiver module.

Typically, singlemode fiber has a yellow jacket and multimode cable has an orange jacket.

**NOTE** For proper cooling and air flow, boards and/or blank panels should be installed in all locations during normal switcher operations.

**NOTE** See "A note on I/O boards", on page 2-2, to understand the different arrangement of connectors on the various I/O boards.

Circuit boards can be replaced to accommodate SDI/HD-SDI (electric) signals. They can be added or removed to increase or decrease the I/O configuration (size) of the Fiber Matrix.

Remove and replace an I/O board or blank panel as follows:

**NOTE** The I/O boards are hot-swappable. You do not need to power down the switcher to remove an I/O board.

1. For an I/O board, disconnect any connected cables.
2. Rotate the left and right knurled knobs to completely loosen the captive screws.
3. Gently pull on the knurled knobs/captive screws to loosen the board or panel from the backplane.
4. Slide the board or panel out of the chassis (below).

**CAUTION** Do not touch the electronic components or the connectors on the backplane or on the circuit boards without being electrically grounded. Handle circuit boards by their edges only. Electrostatic discharge can damage circuits, even if you cannot feel, see, or hear it.

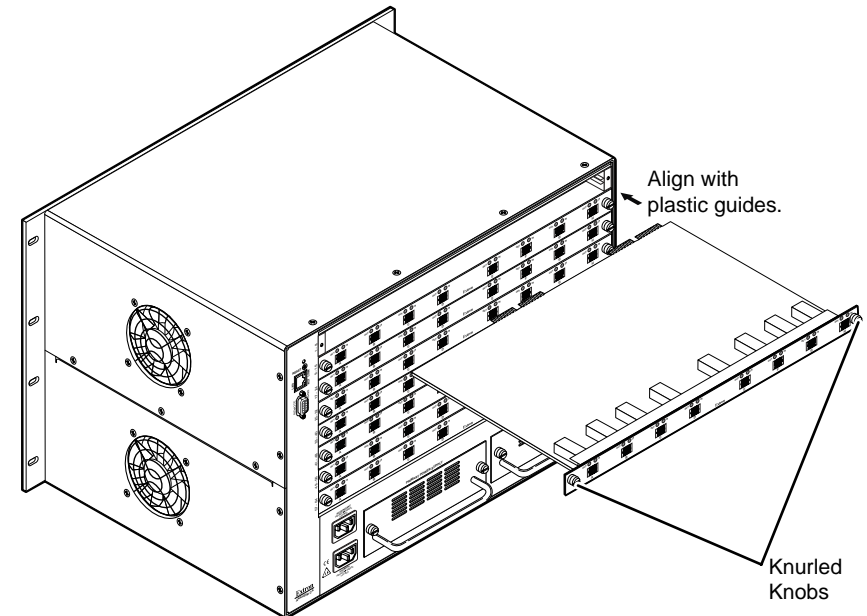

5. Place the removed board on an anti-static surface or in an anti-static container.
6. For an I/O board, orient the board to be installed so that transceiver module A (fiber board) or input BNC A (SDI/HD-SDI board) is on the left and transceiver module or output BNC H is on the right.
7. For an I/O board, align the board with the left and right chassis guides (above).

## Maintenance and Modifications, cont'd

8. Gently slide the board or blank panel into the enclosure. For an I/O board, slide the board toward the front panel until it meets resistance.
9. Gently seat the board or panel in the backplane.
10. Tighten the left and right knurled knobs/captive screws to lock the board or panel in place.

**NOTE** *If necessary, use a screwdriver to tighten the knurled knobs/captive screws.*

## Removing and Installing a Power Supply Module

The two power supply modules (primary power supply and redundant power supply) are identical and hot-swappable. Each power supply module has a 2-color LED, visible on the rear panel, that indicates the status of the power supply outputs. If the LED is lit green, the power supply is operating normally. If the LED is lit red, the supply has failed and should be replaced at the earliest opportunity.

**NOTE** *The power supply modules are hot-swappable. Either power supply can be removed without powering down the switcher. You do not need to power down the switcher to install a power supply.*

1. Rotate the left and right knurled knobs to completely loosen the captive screws.
2. Gently pull on the handle to loosen the power supply from the backplane.
3. Slide the power supply out of the chassis.
4. Orient the power supply module to be installed with the LED to the right.
5. Align the flanges on the power supply module with the left and right power supply guides (see the next page).
6. Gently slide the power supply module into the enclosure until the power supply meets resistance.
7. Gently seat the power supply in the backplane.
8. Tighten the left and right knurled knobs/captive screws to lock the power supply in place.

**NOTE** *If necessary, use a screwdriver to tighten the knurled knobs/captive screws.*

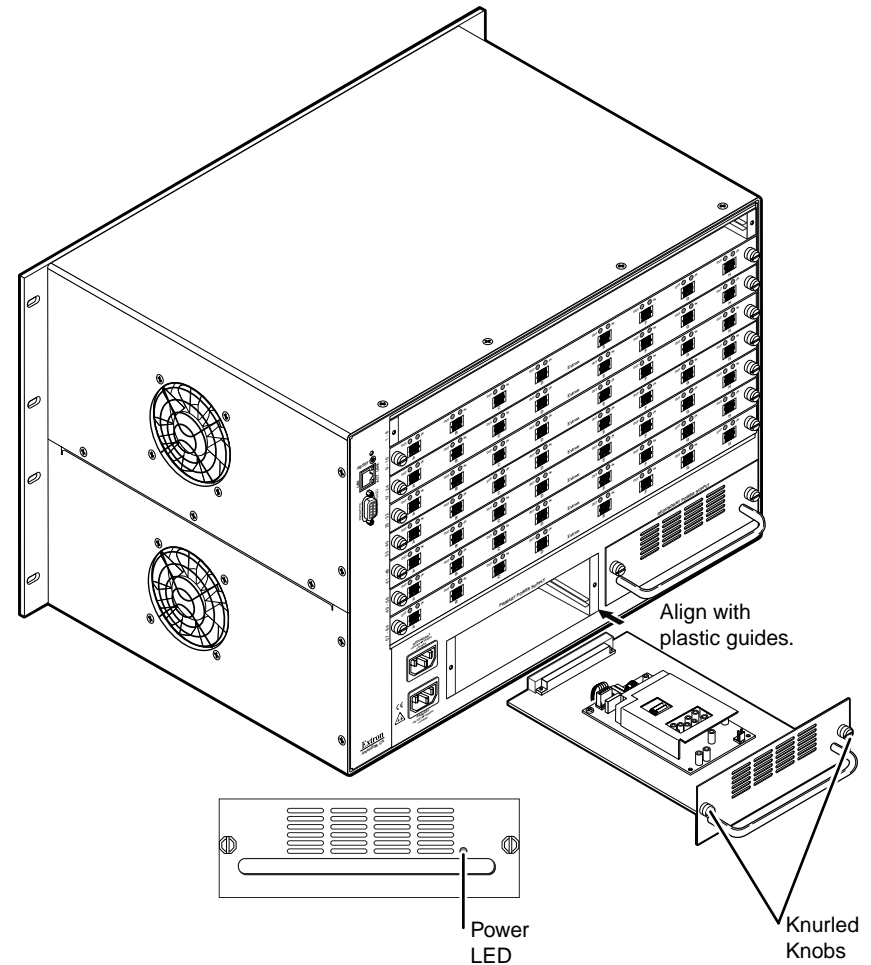

## **Maintenance and Modifications, cont'd**

---