

User's Manual



Fiber Matrix 6400

Configurable Fiber Optic Digital Matrix Switcher

Precautions

Safety Instructions • English



This symbol is intended to alert the user of important operating and maintenance (servicing) instructions in the literature provided with the equipment.



This symbol is intended to alert the user of the presence of uninsulated dangerous voltage within the product's enclosure that may present a risk of electric shock.

Caution

Read Instructions • Read and understand all safety and operating instructions before using the equipment.

Retain Instructions • The safety instructions should be kept for future reference.

Follow Warnings • Follow all warnings and instructions marked on the equipment or in the user information.

Avoid Attachments • Do not use tools or attachments that are not recommended by the equipment manufacturer because they may be hazardous.

Consignes de Sécurité • Français



Ce symbole sert à avertir l'utilisateur que la documentation fournie avec le matériel contient des instructions importantes concernant l'exploitation et la maintenance (réparation).



Ce symbole sert à avertir l'utilisateur de la présence dans le boîtier de l'appareil de tensions dangereuses non isolées posant des risques d'électrocution.

Attention

Lire les instructions • Prendre connaissance de toutes les consignes de sécurité et d'exploitation avant d'utiliser le matériel.

Conservier les instructions • Ranger les consignes de sécurité afin de pouvoir les consulter à l'avenir.

Respecter les avertissements • Observer tous les avertissements et consignes marqués sur le matériel ou présentés dans la documentation utilisateur.

Eviter les pièces de fixation • Ne pas utiliser de pièces de fixation ni d'outils non recommandés par le fabricant du matériel car cela risquerait de poser certains dangers.

Sicherheitsanleitungen • Deutsch



Dieses Symbol soll dem Benutzer in der im Lieferumfang enthaltenen Dokumentation besonders wichtige Hinweise zur Bedienung und Wartung (Instandhaltung) geben.



Dieses Symbol soll den Benutzer darauf aufmerksam machen, daß im Inneren des Gehäuses dieses Produktes gefährliche Spannungen, die nicht isoliert sind und die einen elektrischen Schock verursachen können, herrschen.

Achtung

Lesen der Anleitungen • Bevor Sie das Gerät zum ersten Mal verwenden, sollten Sie alle Sicherheits- und Bedienungsanleitungen genau durchlesen und verstehen.

Aufbewahren der Anleitungen • Die Hinweise zur elektrischen Sicherheit des Produktes sollten Sie aufbewahren, damit Sie im Bedarfsfall darauf zurückgreifen können.

Befolgen der Warnhinweise • Befolgen Sie alle Warnhinweise und Anleitungen auf dem Gerät oder in der Benutzerdokumentation.

Keine Zusatzgeräte • Verwenden Sie keine Werkzeuge oder Zusatzgeräte, die nicht ausdrücklich vom Hersteller empfohlen wurden, da diese eine Gefahrenquelle darstellen können.

Instrucciones de seguridad • Español



Este símbolo se utiliza para advertir al usuario sobre instrucciones importantes de operación y mantenimiento (o cambio de partes) que se desean destacar en el contenido de la documentación suministrada con los equipos.



Este símbolo se utiliza para advertir al usuario sobre la presencia de elementos con voltaje peligroso sin protección aislante, que puedan encontrarse dentro de la caja o alojamiento del producto, y que puedan representar riesgo de electrocución.

Precaucion

Leer las instrucciones • Leer y analizar todas las instrucciones de operación y seguridad, antes de usar el equipo.

Conservar las instrucciones • Conservar las instrucciones de seguridad para futura consulta.

Obedecer las advertencias • Todas las advertencias e instrucciones marcadas en el equipo o en la documentación del usuario, deben ser obedecidas.

Evitar el uso de accesorios • No usar herramientas o accesorios que no sean específicamente recomendados por el fabricante, ya que podrían implicar riesgos.

安全须知 • 中文



这个符号提示用户该设备用户手册中有重要的操作和维护说明。



这个符号警告用户该设备机壳内有暴露的危险电压，有触电危险。

注意

阅读说明书 • 用户使用该设备前必须阅读并理解所有安全和使用说明。

保存说明书 • 用户应保存安全说明书以备将来使用。

遵守警告 • 用户应遵守产品和用户指南上的所有安全和操作说明。

避免追加 • 不要使用该产品厂商没有推荐的工具或追加设备，以避免危险。

Warning

Power sources • This equipment should be operated only from the power source indicated on the product. This equipment is intended to be used with a main power system with a grounded (neutral) conductor. The third (grounding) pin is a safety feature, do not attempt to bypass or disable it.

Power disconnection • To remove power from the equipment safely, remove all power cords from the rear of the equipment, or the desktop power module (if detachable), or from the power source receptacle (wall plug).

Power cord protection • Power cords should be routed so that they are not likely to be stepped on or pinched by items placed upon or against them.

Servicing • Refer all servicing to qualified service personnel. There are no user-serviceable parts inside. To prevent the risk of shock, do not attempt to service this equipment yourself because opening or removing covers may expose you to dangerous voltage or other hazards.

Slots and openings • If the equipment has slots or holes in the enclosure, these are provided to prevent overheating of sensitive components inside. These openings must never be blocked by other objects.

Lithium battery • There is a danger of explosion if battery is incorrectly replaced. Replace it only with the same or equivalent type recommended by the manufacturer. Dispose of used batteries according to the manufacturer's instructions.

Avertissement

Alimentations • Ne faire fonctionner ce matériel qu'avec la source d'alimentation indiquée sur l'appareil. Ce matériel doit être utilisé avec une alimentation principale comportant un fil de terre (neutre). Le troisième contact (de mise à la terre) constitue un dispositif de sécurité : n'essayez pas de la contourner ni de la désactiver.

Déconnexion de l'alimentation • Pour mettre le matériel hors tension sans danger, déconnectez tous les cordons d'alimentation de l'arrière de l'appareil ou du module d'alimentation de bureau (s'il est amovible) ou encore de la prise secteur.

Protection du cordon d'alimentation • Acheminer les cordons d'alimentation de manière à ce que personne ne risque de marcher dessus et à ce qu'ils ne soient pas écrasés ou pincés par des objets.

Réparation-maintenance • Faire exécuter toutes les interventions de réparation-maintenance par un technicien qualifié. Aucun des éléments internes ne peut être réparé par l'utilisateur. Afin d'éviter tout danger d'électrocution, l'utilisateur ne doit pas essayer de procéder lui-même à ces opérations car l'ouverture ou le retrait des couvercles risquent de l'exposer à de hautes tensions et autres dangers.

Fentes et orifices • Si le boîtier de l'appareil comporte des fentes ou des orifices, ceux-ci servent à empêcher les composants internes sensibles de surchauffer. Ces ouvertures ne doivent jamais être bloquées par des objets.

Lithium Batterie • Il a danger d'explosion s'il y a remplacement incorrect de la batterie. Remplacer uniquement avec une batterie du même type ou d'un type équivalent recommandé par le constructeur. Mettre au rebut les batteries usagées conformément aux instructions du fabricant.

Vorsicht

Stromquellen • Dieses Gerät sollte nur über die auf dem Produkt angegebene Stromquelle betrieben werden. Dieses Gerät wurde für eine Verwendung mit einer Hauptstromleitung mit einem geerdeten (neutralen) Leiter konzipiert. Der dritte Kontakt ist für einen Erdschluß, und stellt eine Sicherheitsfunktion dar. Dieses sollte nicht umgangen oder außer Betrieb gesetzt werden.

Stromunterbrechung • Um das Gerät auf sichere Weise vom Netz zu trennen, sollten Sie alle Netzkabel aus der Rückseite des Gerätes, aus der externen Stromversorgung (falls dies möglich ist) oder aus der Wandsteckdose ziehen.

Schutz des Netzkabels • Netzkabel sollten stets so verlegt werden, daß sie nicht im Weg liegen und niemand darauf treten kann oder Objekte darauf- oder unmittelbar dagegengestellt werden können.

Wartung • Alle Wartungsmaßnahmen sollten nur von qualifiziertem Servicepersonal durchgeführt werden. Die internen Komponenten des Gerätes sind wartungsfrei. Zur Vermeidung eines elektrischen Schocks versuchen Sie in keinem Fall, dieses Gerät selbst öffnen, da beim Entfernen der Abdeckungen die Gefahr eines elektrischen Schlags und/oder andere Gefahren bestehen.

Schlitze und Öffnungen • Wenn das Gerät Schlitze oder Löcher im Gehäuse aufweist, dienen diese zur Vermeidung einer Überhitzung der empfindlichen Teile im Inneren. Diese Öffnungen dürfen niemals von anderen Objekten blockiert werden.

Lithium-Batterie • Explosionsgefahr, falls die Batterie nicht richtig ersetzt wird. Ersetzen Sie verbrauchte Batterien nur durch den gleichen oder einen vergleichbaren Batterietyp, der auch vom Hersteller empfohlen wird. Entsorgen Sie verbrauchte Batterien bitte gemäß den Herstelleranweisungen.

Advertencia

Alimentación eléctrica • Este equipo debe conectarse únicamente a la fuente/tipo de alimentación eléctrica indicada en el mismo. La alimentación eléctrica de este equipo debe provenir de un sistema de distribución general con conductor neutro a tierra. La tercera pata (puesta a tierra) es una medida de seguridad, no puentearla ni eliminarla.

Desconexión de alimentación eléctrica • Para desconectar con seguridad la acometida de alimentación eléctrica al equipo, desenchufar todos los cables de alimentación en el panel trasero del equipo, o desenchufar el módulo de alimentación (si fuera independiente), o desenchufar el cable del receptáculo de la pared.

Protección del cables de alimentación • Los cables de alimentación eléctrica se deben instalar en lugares donde no sean pisados ni apretados por objetos que se puedan apoyar sobre ellos.

Reparaciones/mantenimiento • Solicitar siempre los servicios técnicos de personal calificado. En el interior no hay partes a las que el usuario deba acceder. Para evitar riesgo de electrocución, no intentar personalmente la reparación/mantenimiento de este equipo, ya que al abrir o extraer las tapas puede quedar expuesto a voltajes peligrosos u otros riesgos.

Ranuras y aberturas • Si el equipo posee ranuras o orificios en su caja/alojamiento, es para evitar el sobrecalentamiento de componentes internos sensibles. Estas aberturas nunca se deben obstruir con otros objetos.

Batería de litio • Existe riesgo de explosión si esta batería se coloca en la posición incorrecta. Cambiar esta batería únicamente con el mismo tipo (o su equivalente) recomendado por el fabricante. Desachar las baterías usadas siguiendo las instrucciones del fabricante.

警告

电源 • 该设备只能使用产品上标明的电源。设备必须使用有地线的供电系统供电。第三条线（地线）是安全设施，不能不用或跳过。

拔掉电源 • 为安全地从设备拔掉电源，请拔掉所有设备后或桌面电源的电源线，或任何接到市电系统的电源线。

电源线保护 • 妥善布线，避免被踩踏，或重物挤压。

维护 • 所有维修必须由认证的维修人员进行。设备内部没有用户可以更换的零件。为避免出现触电危险不要自己试图打开设备盖子维修该设备。

通风孔 • 有些设备机壳上有通风槽或孔，它们是用来防止机内敏感元件过热。不要有任何东西挡住通风孔。

锂电池 • 不正确的更换电池会有爆炸的危险。必须使用与厂家推荐的相同或相近型号的电池。按照生产厂的建议处理废弃电池。

FCC Class A Notice

This equipment has been tested and found to comply with the limits for a Class A digital device, pursuant to part 15 of the FCC Rules. Operation is subject to the following two conditions: (1) this device may not cause harmful interference, and (2) this device must accept any interference received, including interference that may cause undesired operation. The Class A limits are designed to provide reasonable protection against harmful interference when the equipment is operated in a commercial environment. This equipment generates, uses, and can radiate radio frequency energy and, if not installed and used in accordance with the instruction manual, may cause harmful interference to radio communications. Operation of this equipment in a residential area is likely to cause harmful interference, in which case the user will be required to correct the interference at his own expense.

NOTE *This unit was tested with shielded cables on the peripheral devices. Shielded cables must be used with the unit to ensure compliance with FCC emissions limits.*

Table of Contents

Chapter One • Introduction	1-1
About this Manual	1-2
About the Fiber Matrix 6400 Switcher	1-2
Fiber cable transmission modes	1-4
Definitions	1-4
Features	1-4
Chapter Two • Installation	2-1
Setup/Installation Checklist	2-2
Get ready.....	2-2
Configure the Fiber Matrix.....	2-2
Perform physical installation.....	2-2
Ancillary operations.....	2-2
Mounting the Switcher	2-2
UL guidelines	2-2
Mounting instructions.....	2-2
Rear Panel Cabling and Features	2-3
I/O boards.....	2-4
Reset button and LED.....	2-6
Ethernet connection	2-6
Cabling	2-6
RJ-45 connector wiring.....	2-7
Remote port.....	2-7
Power	2-8
Front Panel Configuration Port	2-8
Chapter Three • Operation	3-1
Front Panel Controls and Indicators	3-2
Input and output buttons.....	3-3
Control buttons.....	3-4
Power indicators.....	3-6
Button labels.....	3-6
Rear Panel Power Indicators	3-7
Front Panel Operations	3-7
Definitions.....	3-8
Power	3-8
Creating a configuration	3-9
Example 1: Creating a set of ties	3-10
Example 2: Adding a tie to a set of ties	3-11
Example 3: Removing a tie from a set of ties	3-13
Viewing a configuration	3-14
Example 4: Viewing ties	3-15

Table of Contents, cont'd

I/O grouping.....	3-17
Example 5: Grouping inputs and outputs.....	3-19
Using presets.....	3-21
Example 6: Saving a preset	3-21
Example 7: Recalling a preset	3-22
Muting and unmuting outputs.....	3-23
Example 9: Muting and unmuting an output.....	3-24
Locking out the front panel (Executive mode)	3-25
Performing a system reset from the front panel.....	3-26
Background illumination	3-26
Selecting the rear panel Remote port protocol and baud rate	3-27
Rear Panel Operations	3-28
Performing soft system resets (resets 3, 4, and 5).....	3-29
Performing a hard reset (reset 1)	3-30
Troubleshooting	3-31
Configuration Worksheets	3-32
Worksheet example 1: System equipment.....	3-32
Worksheet example 2: Daily configuration.....	3-34
Worksheet example 3: Test configuration	3-36
Blank configuration worksheet	3-38
Chapter Four • Programmer's Guide	4-1
Serial Ports	4-2
Rear panel Remote port.....	4-2
Front panel Configuration port.....	4-3
Ethernet (LAN) Port	4-4
Ethernet connection	4-4
Default IP addresses.....	4-4
Establishing a connection	4-5
Connection Timeouts.....	4-5
Number of connections.....	4-5
Using Verbose Mode.....	4-5
Host-to-Switcher Instructions	4-6
Switcher-Initiated Messages	4-6
Switcher Error Responses	4-7
Using the Command/Response Tables	4-7
Symbol definitions	4-8
Command/response table for SIS commands.....	4-9
Command/Response Table for IP-Specific SIS Commands	4-17
Symbol definitions	4-17
Command/response table for IP-Specific SIS commands	4-18
Special Characters	4-19

Chapter Five • Matrix Software	5-1
Matrix Switchers Control Program	5-2
Installing the software	5-2
Software operation via Ethernet	5-3
Using the Matrix Switcher Control software	5-4
IP Settings/Options window	5-8
Address and Name fields.....	5-9
Hardware Address field.....	5-9
Use DHCP checkbox.....	5-9
Date, Time (local), and GMT (offset) fields	5-10
Sync Time to PC button	5-10
Use Daylight Savings checkbox.....	5-10
Administrator Password and User Password fields.....	5-10
E-mail Addressee fields	5-11
Updating firmware	5-12
Ethernet-connected firmware upload.....	5-14
Serial-port-connected firmware upload.....	5-15
Uploading HTML files.....	5-17
Windows buttons, drop boxes, and trash can	5-18
Windows menus.....	5-18
File menu	5-18
Tools menu.....	5-19
Preferences menu.....	5-21
Master-Reset selection	5-21
Using Emulation mode.....	5-22
Using the help system	5-22
Button-Label Generator Program	5-23
Installing the Button-Label Generator software.....	5-23
Using the Button-Label Generator software	5-24
Chapter Six • HTML Operation	6-1
Opening the Switcher’s Embedded Web Pages	6-2
Status Tab	6-3
System Status page	6-3
Input Link page	6-4
Configuration Tab	6-5
System Settings page.....	6-5
IP Settings fields	6-5
Unit Name field.....	6-5
DHCP radio buttons.....	6-6
IP Address field	6-6
Gateway IP Address field.....	6-6
Subnet Mask field	6-6
MAC Address field	6-6
Firmware field.....	6-6
Model field.....	6-6
Part Number field	6-6
Date/Time Settings fields	6-7

Table of Contents, cont'd

Passwords page	6-8
Email Settings page	6-9
Mail IP Address field.....	6-9
Domain Name field	6-9
Email Address fields.....	6-10
Firmware Upgrade page	6-10
File Management Tab	6-12
File Management page	6-12
Special Characters	6-12
Chapter Seven • Maintenance and Modifications	7-1
Removing and Installing the I/O Board or Blank Panel	7-2
Removing the I/O board or blank panel.....	7-3
Installing the I/O board or blank panel	7-4
Removing and Installing the Power Supply Module	7-4
Removing the power supply module.....	7-4
Installing the power supply module	7-5
Removing and Installing Button Labels	7-6
Installing labels in the matrix switcher's buttons.....	7-6
Button label blanks.....	7-7
Appendix A • Ethernet Connection	A-1
Ethernet Link	A-2
Ethernet connection	A-2
Default IP address	A-2
Pinging to determine Extron IP address.....	A-2
Pinging to determine Web IP address.....	A-3
Connecting as a Telnet client	A-3
Telnet tips.....	A-4
Open	A-4
Escape character and Esc key	A-4
Local echo.....	A-4
Set carriage return-line feed.....	A-5
Close	A-5
Help	A-5
Quit.....	A-5
Subnetting — A Primer	A-6
Gateways.....	A-6
Local and remote devices.....	A-6
IP addresses and octets.....	A-6
Subnet masks and octets.....	A-6
Determining whether devices are on the same subnet	A-7

Appendix B • Specifications, Part Numbers, Accessories	B-1
Specifications	B-2
Part Numbers and Accessories	B-5
Fiber Matrix switcher part numbers.....	B-5
Included parts.....	B-5
Replacement/configuration change parts.....	B-5
Optional accessories	B-6

Table of Contents, cont'd



Fiber Matrix 6400 Switcher

1 Chapter One

Introduction

About this Manual

About the Fiber Matrix 6400 Switcher

Definitions

Features

Introduction

About this Manual

This manual contains installation, configuration, and operating information for the Extron Fiber Matrix 6400 matrix switcher with user-replaceable singlemode fiber optic I/O boards, multimode fiber optic I/O boards, and serial digital interface (SDI) and high definition serial digital interface (HD-SDI) I/O boards.

NOTE *The multimode and singlemode fiber optic I/O boards are physically and functionally identical, with the exception of the effective range of transmission. In this manual, any reference to fiber optic transmission applies to either transmission mode unless otherwise specified.*

About the Fiber Matrix 6400 Switcher

WARNING *The Fiber Matrix 6400's fiber optic I/O boards output continuous invisible light, which may be harmful and dangerous to the eyes; use with caution.*

- **Do not look** into the rear panel fiber optic cable connectors or into the fiber optic cables themselves.
- Plug the attached dust caps into the optical transceivers when the fiber optic cable is unplugged.

The Fiber Matrix 6400 (figure 1-1) is a configurable matrix switcher that distributes optical and electrical signals. Fiber optic I/O boards route signals that are compatible with all Extron FOX 500 fiber optic product lines. SDI/HD-SDI I/O boards route SDI and HD-SDI signals. The matrix switcher routes any input signal to any combination of outputs. An optical input can be tied to optical and/or SDI/HD-SDI outputs and an SDI/HD-SDI input can be tied to SDI/HD-SDI and/or optical outputs. The matrix switcher can route multiple input/output configurations simultaneously.

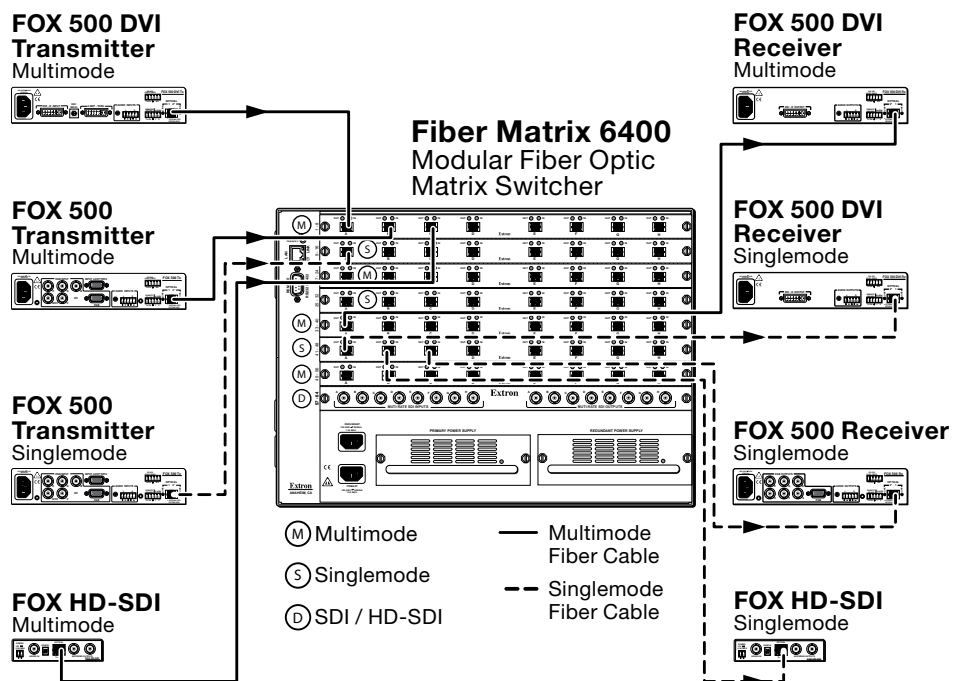

Figure 1-1 — Typical Fiber Matrix 6400 application

The Extron proprietary fiber optic signal, generated by equipment such as FOX 500 transmitters, can include video, stereo audio, and transmitter-to-receiver RS-232 serial communications. The video component of the signal can be RGB video, Digital Visual Interface (DVI) video, SDI/HD-SDI video, or low resolution video, depending on the transmitter and receiver. The switcher has two internal, hot-swappable 100 VAC to 240 VAC, 50-60 Hz, 180-watt power supplies that provide worldwide power compatibility and reliability.

NOTE *Compatible optical signals are digital signals from 270 Mbs through 4.25 Gbps that are sent and received via fiber optic small form factor pluggable (SFP) modules. The Fiber Matrix 6400 supports all compatible optical signals, whether transmitted or received by an Extron FOX system component or not.*

NOTE *The FOX 500 transmitter-to receiver communications, including the serial link, occupy one matrix switcher input and output. This matrix switcher also supports the FOX 500 return (receiver-to-transmitter) serial communications, but returning this signal stream to the transmitter occupies a separate matrix switcher input and output.*

The matrix switcher is a single box solution to complex fiber optic and/or SDI/HD-SDI signal routing applications. Each input and output is individually isolated and buffered, and any input(s) can be switched to any one or all outputs with virtually no crosstalk or signal noise between channels.

The Fiber Matrix is assembled from individual input/output (I/O) boards. The switcher can include up to eight I/O boards, each of which supports 8 inputs by 8 outputs. By adding or removing I/O boards, the Fiber Matrix is expandable and contractable, from an 8-input by 8-output matrix to a 64-input by 64-output matrix. The matrix switcher inputs and outputs the optical signals that it routes on fiber optic transceiver modules and the SDI/HD-SDI video signals on BNC connectors.

The matrix switcher can be remotely controlled via its rear panel RS-232/RS-422 Remote port, its rear panel LAN port, and its front panel Configuration (RS-232) port using either Extron's Windows®-based Matrix Switchers Control Program or the Simple Instruction Set (SIS™). The SIS is a set of basic ASCII code commands that provide simple control through a control system or PC without programming long, obscure strings of code. SIS commands can be entered via either serial port.

The switcher can be operated remotely by any of the following connected to either serial port:

- a control system
- a PC
- an Extron MKP 2000 or MKP 3000 remote control panel
- (RS-232/RS-422 only) an Extron MCP 1000 remote control panel and/or MKP 1000 remote keypad

The matrix switcher is housed in a rack-mountable, 7U high metal enclosure with mounting flanges for standard 19" racks.

Fiber cable transmission modes

Two versions of Fiber Matrix switcher fiber optic I/O boards are documented in this manual. They are categorized by the type of fiber optic cable, multimode or singlemode, which defines the effective range of transmission:

- **Multimode** — Long distance, up to 300 m (985')
- **Singlemode** — Very long distance, up to 30 km (18.75 miles)

NOTE *All transceiver modules on a fiber optic I/O board, as delivered from Extron, are configured the same; either all multimode or all singlemode.*

NOTE *You can mix multimode and singlemode fiber optic I/O boards in a Fiber Matrix switcher, but you must ensure that you connect the proper transmission mode fiber cables to the board.*

Definitions

The following terms, which apply to all Extron matrix switchers, are used throughout this manual:

Tie — An input-to-output connection.

Set of ties — An input tied to two or more outputs. (An output can never be tied to more than one input.)

Configuration — One or more ties or one or more sets of ties.

Current configuration — The configuration that is currently active in the switcher (also called “configuration 0”).

Global memory preset — A configuration that has been stored. Up to 64 global memory presets can be stored in memory. When a preset is retrieved from memory, it becomes the current configuration. Presets can be saved and recalled from the front panel and any of the serial or LAN ports. For front panel operations, preset locations are assigned to the input buttons.

Room — A subset of outputs that are logically related to each other, as determined by the operator. The switchers support up to 10 rooms, each of which can have up to 10 presets.

Room memory preset — A configuration consisting of outputs in a single room that has been stored. When a room preset is retrieved from memory, it becomes the current configuration.

Features

Fiber optic inputs and outputs — With fiber optic I/O boards, the switchers input and output fiber optic signals on optical connectors. The fiber optic I/O boards support digital signals from 270 Mbps through 4.25 Gbps.

SDI, HD-SDI, or 3G-SDI inputs and outputs — With SDI/HD-SDI I/O boards, the switchers input and output SDI and HD-SDI signals on BNC connectors. The SDI/HD-SDI I/O boards support multi-rate SDI at rates up to 2.97 Gbps, and comply with SMPTE 259M-C, 292M, 424M, and ITU digital video standards.

Cross-format compatibility —

- An input on an SDI/HD-SDI I/O board can be tied to an output on a fiber optic I/O board.
- An input on a fiber optic I/O board can be tied to an output on an SDI/HD-SDI I/O board.

Switching flexibility — The switcher provides individually buffered, independent matrix switched outputs.

- **Tie any input to any or all outputs.**
- **Quick multiple tie** — Multiple inputs can be switched to multiple outputs simultaneously. This allows all displays (outputs) to change from source to source at the same time.

Input link detection — In critical environments or unmanned, remote locations, it may be vital to know that sources are active and switching. The switcher confirms that input sources are active by detecting light. Link detection provides instantaneous feedback via the switchers' serial ports or LAN port. The input information can be displayed on any control system or in a Windows-based control program on a local-area network (LAN) or Internet (IP) connection.

Rooming — The switcher can be programmed to group multiple outputs to specific "rooms", allowing them to have their own presets.

Operational reliability — The Fiber Matrix 6400 can support round-the-clock operation in mission-critical applications, using a combination of hot-swappable components and redundant power supplies.

- **Field upgradable, hot-swappable modular design** — The architecture of the Fiber Matrix 6400 allows you to repair, upgrade, reconfigure, or expand the matrix by simply installing a new I/O board or replacing a board of one type with one of another. Hot-swappable components let you replace any I/O board at any time — without powering down the switcher.
- **Primary and redundant, hot-swappable power supplies** — The hot-swappable, externally mounted redundant power supply is configured to automatically take over the load from the primary supply in the case of a failure.

The complete power circuit, from the plug, through the power supply, to the power's insertion onto the power distribution plane, is separate and redundant (figure 1-2). If the installation includes uninterruptible or completely separate power sources, the switcher will remain powered up through any power interruption short of a simultaneous loss of power on both power sources.

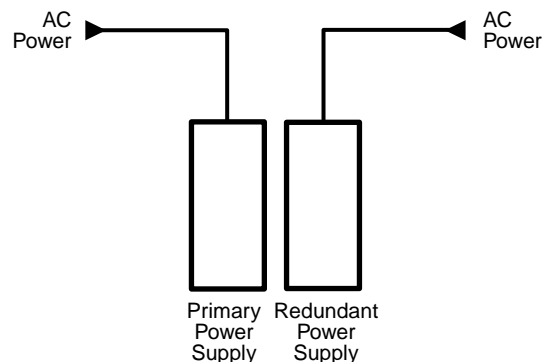

Figure 1-2 — Redundant power supply backs up primary

Introduction, cont'd

The hot-swappable redundant power supply means zero downtime for the switcher and no loss of functionality should one power supply fail. Should a primary power supply fail, the redundant power supply immediately assumes the load of the failed primary supply. A failed power supply is easily replaceable from the rear at any time—without powering down the matrix, and with no tools required.

- **Two AC power inputs**

Operational flexibility — Operations such as input/output selection and setting of presets can be performed on the front panel or via the Ethernet or either serial port link. The serial ports allow remote control via a PC or a control system. The Ethernet link allows multiple remote links with two levels of password protection.

- **Front Panel Controller**
- **Windows-based control/configuration program**
- **Simple Instruction Set (SIS)**
- **Remote control panels and keypads**

Upgradeable firmware — The firmware that controls all switcher operation can be upgraded in the field via RS-232/RS-422 or Ethernet, without taking the switcher out of service. Firmware upgrades are available for download on the Extron Web site, www.extron.com, and can be installed using the Windows-based control/configuration program or the built-in HTML pages.

Labeling — Extron's included button label software lets you create labels to place in the front panel I/O buttons, with names, alphanumeric characters, or color bitmaps for easy and intuitive input and output selection. Alternatively, labels can be made with any Brother™ P-Touch™ or comparable labeler.

Global memory presets

Rack mountability

Front panel security lockout modes (*Executive mode*) — If a matrix switcher is installed in an open area, where operation by unauthorized personnel may be a problem, a security lockout mode can be implemented. When the front panel is locked, a special button combination or SIS command is required to unlock the front panel controller and make the front panel fully operational.

I/O grouping



Fiber Matrix 6400 Switcher

2 Chapter Two

Installation

Setup/Installation Checklist

Mounting the Switcher

Rear Panel Cabling and Features

Front Panel Configuration Port

Installation

Setup/Installation Checklist

Get ready

- Familiarize yourself with the Fiber Matrix switchers.
- Obtain IP setting information for the Fiber Matrix from the local network administrator. Read Appendix A, "Ethernet Connection".

Configure the Fiber Matrix

- Install the desired I/O boards (page 7-4).

Perform physical installation

- If desired, create (page 5-25) and replace button labels (page 7-6).
- If desired, install the switcher in a rack (below).
- Cable input and output devices to the I/O ports (page 2-5).
- If desired, connect computers or control systems to the serial ports and/or LAN port (page 2-6, page 2-8, and page 2-9).
- Connect power (page 2-8).
- Test the switcher by creating a tie (page 3-10).

Ancillary operations

- Install the Windows-based control/configuration program (page 5-2).

Mounting the Switcher

UL guidelines

The following Underwriters Laboratories (UL) guidelines pertain to the installation of the Fiber Matrix into a rack.

1. **Elevated operating ambient temperature** — If the equipment installed in a closed or multi-unit rack assembly, the operating ambient temperature of the rack environment may be greater than room ambient temperature. Therefore, install the Fiber Matrix in an environment compatible with the maximum ambient temperature ($T_{ma} = +122\text{ }^{\circ}\text{F}$, $+50\text{ }^{\circ}\text{C}$) specified by Extron.
2. **Reduced air flow** — Install the equipment in a rack so that the amount of air flow required for safe operation of the equipment is not compromised.
3. **Mechanical loading** — Mount the equipment in the rack so that a hazardous condition is not achieved due to uneven mechanical loading.
4. **Circuit overloading** — Connect the equipment to the supply circuit and consider the effect that circuit overloading might have on overcurrent protection and supply wiring. Appropriate consideration of equipment nameplate ratings should be used when addressing this concern.
5. **Reliable earthing (grounding)** — Maintain reliable grounding of rack-mounted equipment. Pay particular attention to supply connections other than direct connections to the branch circuit (e.g. use of power strips).

Mounting instructions

The Fiber Matrix 6400 matrix switcher is housed in a rack-mountable, 7U high metal enclosure with mounting flanges for standard 19" racks. If desired, rack mount the switcher as follows:

1. Insert the switcher into the rack, aligning the holes in the mounting bracket with those in the rack.
2. Secure the switcher to the rack using the supplied bolts.

Rear Panel Cabling and Features

WARNING

The Fiber Matrix 6400 fiber optic I/O boards output continuous invisible light, which may be harmful and dangerous to the eyes; use with caution.

- Do not look into the rear panel fiber optic cable connectors or into the fiber optic cables themselves.
- Plug the attached dust caps into the optical transceivers when the fiber optic cable is unplugged.

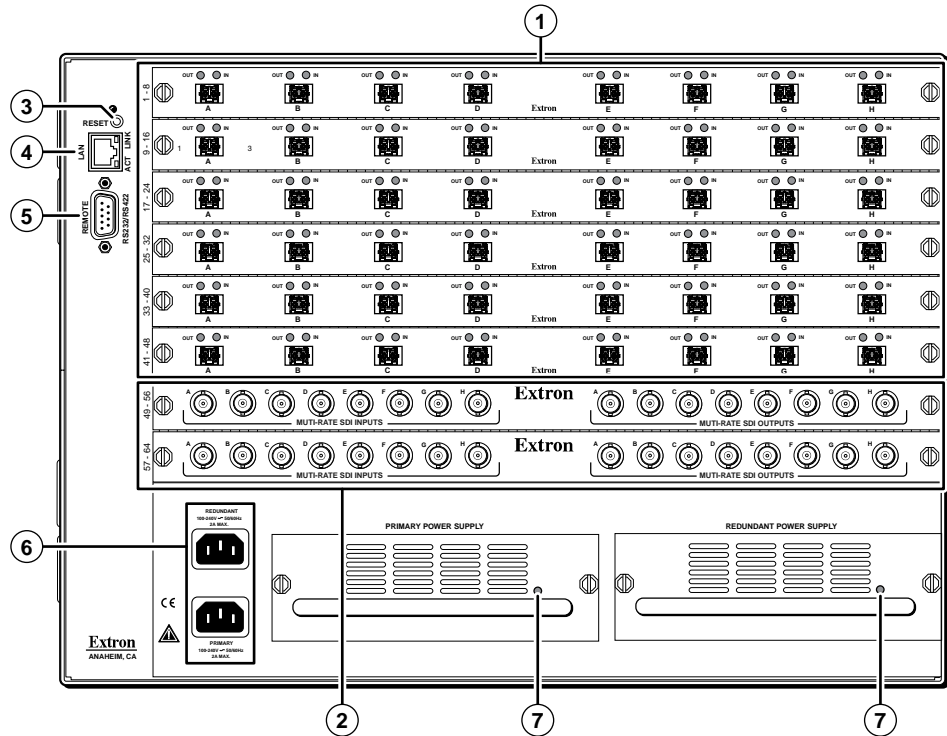

Figure 2-1 — Fiber Matrix 6400 fiber optic matrix switcher rear panel

CAUTION

Use electrostatic discharge (ESD) precautions (be electrically grounded) when making connections. Electrostatic discharge can damage equipment, even if you cannot feel, see, or hear it.

Remove system power before making all connections.

- ① Fiber optic connectors and LEDs — See page 2-5.
- ② SDI/HD-SDI connectors and LEDs — See page 2-5.
- ③ Reset button — See page 2-6.
- ④ Ethernet connection (LAN connector) — See page 2-6.
- ⑤ Remote port — See page 2-8.
- ⑥ Power connectors — See page 2-8.
- ⑦ Power indicator LEDs — See page 2-8.

Installation, cont'd

I/O boards

The transceiver modules on fiber optic I/O boards and the BNC connectors on SDI/HD-SDI boards are identified as A through H. Each I/O board is identified by the input and output numbers supported by the board position (1 - 8, 9 - 16, and so on). See figure 2-2.

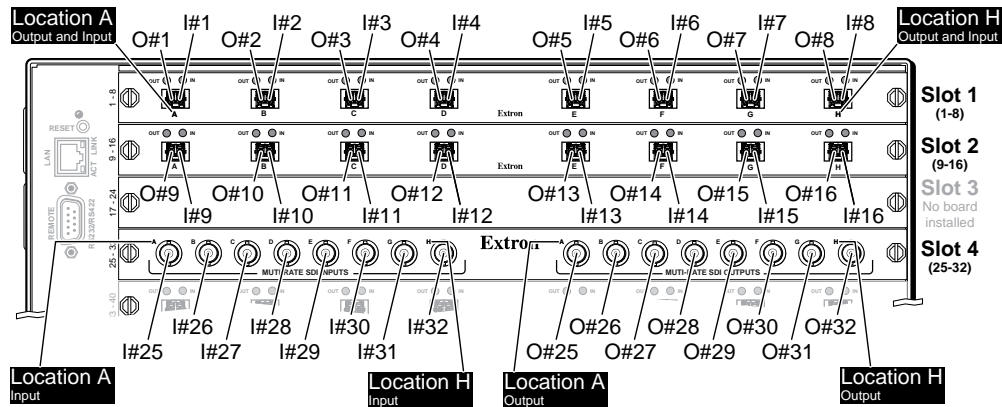

Figure 2-2 — Arrangement of inputs and outputs on the I/O boards

Slot	Inputs and outputs
1	1 through 8
2	9 through 16
3	17 through 24
4	25 through 32
5	33 through 40
6	41 through 48
7	49 through 56
8	57 through 64

Locations A through H correspond to the output and input numbers identified by the board position numbers. (For example, the output and input numbers supported by the I/O board in location 9 - 16 are as follows: A = 9, B = 10, C = 11, D = 12, E = 13, F = 14, G = 15, and H = 16.)

On the fiber optic I/O boards, locations A through H correspond to the transceiver modules, each of which includes an output and an input. Therefore, locations A through H are numbered from left to right.

On the SDI/HD-SDI I/O boards, inputs and outputs are grouped separately, with inputs A through H on the left and outputs A through H on the right.

① Fiber optic connectors and LEDs —

WARNING This unit outputs continuous invisible light, which may be harmful and dangerous to the eyes; use with caution. For additional safety, plug the attached dust caps into the optical transceivers when the fiber optic cable is unplugged.

NOTE Ensure that you use the proper fiber cable for your I/O board. Typically, singlemode fiber has a yellow jacket and multimode cable has an orange jacket.

NOTE Unlike the FOX 500 transmitters and receivers, which output an optical stream on one connector in a block and receive a return optical stream on the second connector in the same block, the Fiber Matrix 6400 uses one connector on the block as an input and the second connector on the same block as a separate output.

①a **Input connector** — For all one-way video, audio, and/or serial communications output by a transmitter, connect a fiber optic cable to the Input LC connector.

Connect the free end of this fiber optic cable to the Optical 1 LC connector on a FOX 500 Tx transmitter or to any other compatible Extron FOX 500 device.

NOTE Or, for the FOX 500 serial return, (receiver-to-transmitter) function, connect the free end to the Optical 2 connector on a FOX 500 Rx receiver.

Input LED — When lit, the link is active (light is received).

①b **Output connector** — For all one-way video, audio, and/or serial communications output to a receiver, connect a fiber optic cable to the Output LC connector.

Connect the free end of this fiber optic cable to the Optical 1 LC connector on a FOX 500 Rx receiver or to any other compatible Extron FOX 500 device.

NOTE Or, for the FOX 500 serial return, (receiver-to-transmitter) function, connect the free end to the Optical 2 connector on a FOX 500 Tx transmitter.

Output LED — Light is always output, even when no input is tied to the output. This LED is always lit.

② BNC connectors —

②a **Multi-rate SDI Input connectors** — Connect HD-SDI, SDI, or 3G-SDI video inputs to these BNC connectors.

②b **Multi-rate SDI Output connectors** — Connect digital displays to these BNC connectors.

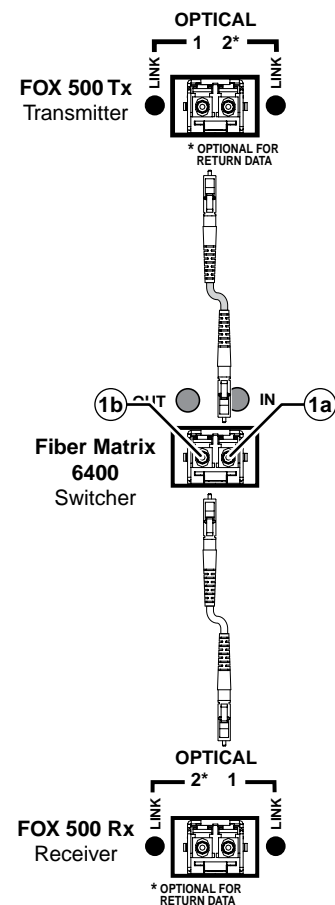

Figure 2-3 — Optical connections

Installation, cont'd

Reset button and LED

- ③ **Reset button** — The Reset button initiates four levels of reset of the matrix switcher. For four different reset levels, press and hold the button while the switcher is running or while you power up the switcher.



See “Rear Panel Operations” in chapter 3, “Operation”, for details.

- **Events (mode 3) reset** — Hold Reset for 3 seconds, then release it and push it again to toggle events monitoring on and off.
- **IP settings (mode 4) reset** — Hold Reset for 6 seconds, then release it and push it again to reset the switcher’s IP functions.

NOTE *The IP settings reset does not replace any user-installed firmware.*

- **Absolute (mode 5) reset** — Hold Reset for 9 seconds, then release it and push it again to restore the switcher to the default factory conditions.
- **Hard reset** — Hold Reset while powering up the switcher to restore the switcher to the default factory conditions.

NOTE *Factory loaded firmware is active until it is replaced or the power is cycled.*

Hard reset does not clear the current configuration.

Ethernet connection

- ④ **LAN port** — If desired, for IP control of the system, connect the matrix switcher to a PC or to an Ethernet LAN, via this RJ-45 connector. You can use a PC to control the networked switcher with SIS commands from anywhere in the world. You can also control the switcher from a PC that is running Extron’s Windows-based control/configuration program or has downloaded HTML pages from the switcher.

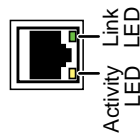

Link LED indicator — The Link LED indicates that the switcher is properly connected to an Ethernet LAN. This LED should light steadily.

Act LED indicator — The Act LED indicates transmission of data packets on the RJ-45 connector. This LED should flicker as the switcher communicates.

Cabling

It is vital that your Ethernet cables be the correct cable type and that they be properly terminated with the correct pinout. Ethernet links use Category (CAT) 3, CAT 5e, or CAT 6, unshielded twisted pair (UTP) or shielded twisted pair (STP) cables, terminated with RJ-45 connectors. Ethernet cables are limited to a length of 328’ (100 m).

NOTE *Do not use standard telephone cables. Telephone cables do not support Ethernet or Fast Ethernet.*

Do not stretch or bend cables. Transmission errors can occur.

The cable used depends on your network speed. The switcher supports both 10 Mbps (10Base-T — Ethernet) and 100 Mbps (100Base-T — Fast Ethernet), half-duplex and full-duplex Ethernet connections.

- 10Base-T Ethernet requires CAT 3 UTP or STP cable at minimum.
- 100Base-T Fast Ethernet requires CAT 5e UTP or STP cable at minimum.

RJ-45 connector wiring

The Ethernet cable can be terminated as a straight-through cable or a crossover cable and must be properly terminated for your application (figure 2-4).

- **Crossover cable** — Direct connection between the computer and the Fiber Matrix switcher
- **Patch (straight) cable** — Connection of the Fiber Matrix switcher to an Ethernet LAN

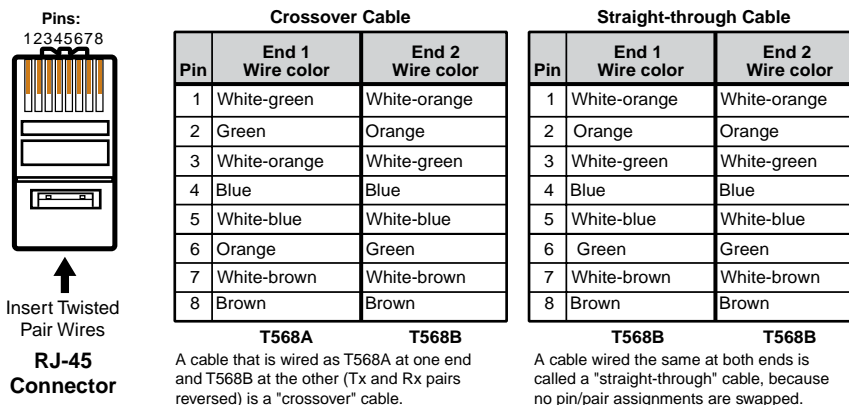

Figure 2-4 — RJ-45 connector and pinout tables

Remote port

- ⑤ **Remote RS-232/RS-422 connector** — Connect a host device, such as a computer, touch panel control, or RS-232 capable PDA to the switcher via this 9-pin D connector for serial RS-232/RS-422 control (figure 2-5).

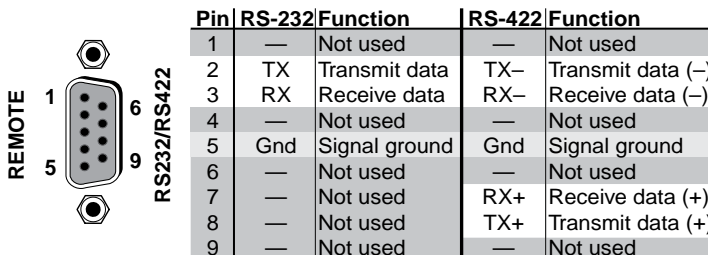

Figure 2-5 — Remote RS-232/RS-422 connector

See chapter 4, "Programmer's Guide", for definitions of the SIS commands (serial commands to control the switcher via this connector) and chapter 5, "Matrix Software", for details on how to install and use the control/configuration software.

NOTE The switcher can support either the RS-232 or RS-422 serial communication protocol, and can operate at 9600, 19200, 38400, or 115200 baud rates. See "Selecting the rear panel Remote port protocol and baud rate" on page 3-27, to configure the RS-232/RS-422 port from the front panel.

If desired, connect an MKP 2000 or MKP 3000 remote control panel to the switcher's RS-232/RS-422 connector. Refer to the *MKP 2000 Remote Control Panel User's Manual* or the *MKP 3000 User's Manual* for details.

Installation, cont'd

Power

- ⑥ **Primary and Redundant AC power connectors** — Plug standard IEC power cords into these connector to connect the switcher to 100 VAC to 240 VAC, 50-60 Hz power sources.

NOTE For the most reliable power, connect the Redundant power cord to either an uninterruptible power source or to a power source that is completely independent from the primary power source.

- ⑦ **Primary and Redundant power supply indicator LEDs** —

Green — Indicates that the associated power supply is operating within normal tolerances.

Red — Indicates that the associated power supply is operating outside the normal tolerances or has failed. See chapter 7, “Maintenance and Modifications” to replace the power supply.

Front Panel Configuration Port

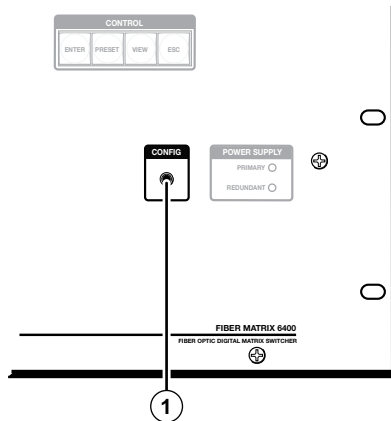

Figure 2-6 — Front panel configuration port

- ① **Configuration port** — This 2.5 mm mini stereo jack serves the same serial communications function as the rear panel Remote port, but it is easier to access than the rear port after the matrix switcher has been installed and cabled. The optional 9-pin D to 2.5 mm mini jack TRS RS-232 cable, part #70-335-01 (figure 2-7), can be used for this connection.

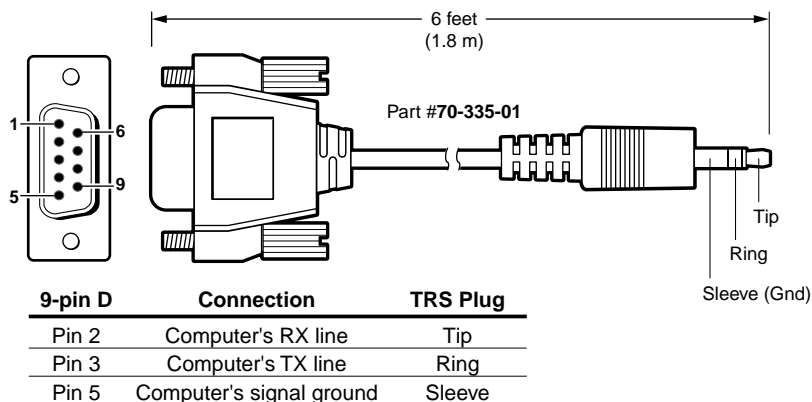

Figure 2-7 — Optional 9-pin TRS RS-232 cable

NOTE *This port is independent of the rear panel Remote port and is not affected by changes to the rear panel port's protocol. This front panel port's protocol can be changed under SIS command control only. See the Command/Response table for IP-specific SIS commands, in chapter 4, "Programmer's Guide", to configure all ports under SIS control.*

NOTE *Both the front panel Configuration port connection and the rear panel Remote port connection can be active at the same time.*

This port is RS-232 only, with its default protocols as follows:

- 9600 baud
- 1 stop bit
- no parity
- no flow control
- 8 data bits

NOTE *The maximum distances from the matrix switcher to the controlling device can vary up to 200 feet (61 m). Factors such as cable gauge, baud rates, environment, and output levels (from the switcher and the controlling device) all affect transmission distance. Distances of about 50 feet (15 m) are typically not a problem. In some cases the matrix switcher may be capable of serial communications via RS-232 up to 250 feet (76 m) away.*

Installation, cont'd



Fiber Matrix 6400 Switcher

Chapter Three

Operation

Front Panel Controls and Indicators

Rear Panel Power Indicators

Front Panel Operations

Rear Panel Operations

Troubleshooting

Configuration Worksheets

Operation

Front Panel Controls and Indicators

The front panel controls (figure 3-1) are grouped into two sets. The input and output buttons are grouped on the left side of the control panel. The control buttons are grouped on the right side of the panel.

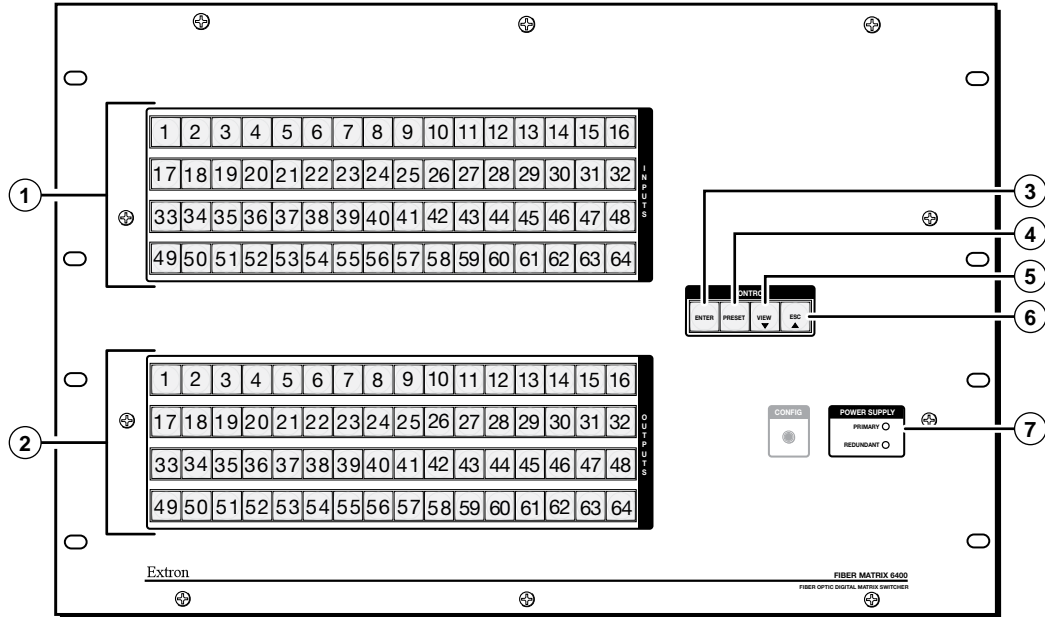







Figure 3-1 — Front panel, Fiber Matrix 6400 matrix switcher

The illuminated pushbuttons can be labeled with text and/or graphics. The buttons can be set to provide amber background illumination all the time or the background illumination can be turned off (see “Background illumination”, on page 3-26). The buttons blink or are lit at full intensity (depending on the operation) when selected.

- ① **Input buttons** — See page 3-3.
- ② **Output buttons** — See page 3-4.
- ③ **Enter button** — See page 3-4.
- ④ **Preset button** — See page 3-5.
- ⑤ **View button** — See page 3-5.
- ⑥ **Esc button** — See page 3-6.
- ⑦ **Power indicators** — See page 3-6.

Input and output buttons



Primary functions			
Action:	Select input or output for tie being created.		
Indications:	<i>Blink:</i> potential tie/untie. <i>Lit:</i> current tie		
			 through  
Secondary functions			
I/O Grouping	Action 1:	<i>Input 1 and Output 1:</i> Select I/O Group mode.	
	Action 2/ indication:	Assign an input or output to the selected group. <i>Lit:</i> Input or output is assigned to the selected group.	
Presets	Action/ indication:	Select a preset in <i>Preset</i> mode. <i>Lit:</i> A preset has already been saved to this location. <i>Blinking:</i> Preset location is selected to be saved.	
Output mutes	Action/ indication:	<i>Outputs:</i> Press and hold to mute the output. <i>Outputs, blinking:</i> Output is muted.	
Port configuration	Action/ indication:		<i>Output 63:</i> Select RS-232. <i>Blink:</i> selected <i>Output 64:</i> Select RS-422. <i>Blink:</i> selected
Background illumination	Action:	<i>Input 1 and Input 2:</i> Toggle between background illumination or buttons unlit.	

- ① **Input buttons** — The input buttons have two primary functions (•) and three secondary functions (□):
- Select an input.
 - Identify the selected input.
 - **(Input 1 only)** With the Output 1 button, select *I/O Group* mode. See “I/O grouping” on page 3-17.
 - Select a preset. See “Using presets” on page 3-21.
 - (Input 1 and Input 2 only) Toggle background illumination of the buttons on and off. See “Background illumination” on page 3-26.

Operation, cont'd

- ② **Output buttons** — The output buttons have two primary functions (•) and four secondary functions (□):
- Select output(s).
 - Identify the selected output(s).
 - **(Output 1 only)** With the Input 1 button, select *I/O Group* mode. See “I/O grouping” on page 3-17.
 - Select a preset. See “Using presets” on page 3-21.
 - Mute the output. See “Muting and unmuting outputs” on page 3-23.
 - **Output 63** — Select the RS-232 protocol for the RS-232/RS-422 port in *Serial Port Selection and Configuration* mode and indicate its selection. See “Selecting the rear panel Remote port protocol and baud rate” on page 3-27.
 - **Output 64** — Select the RS-422 protocol for the RS-232/RS-422 port in *Serial Port Selection and Configuration* mode and indicate its selection. See “Selecting the rear panel Remote port protocol and baud rate” on page 3-27.

Control buttons

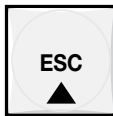
Primary functions					
Action:	Save changes	Select <i>Preset</i> mode	Select <i>View</i> mode	Cancel/escape	
Indication:	<i>Blink:</i> save needed	<i>Blink:</i> Save preset <i>Lit:</i> Recall preset	<i>View</i> mode selected	Flashes once	
					
Secondary functions					
I/O Grouping	Action/indication:	Select group 1.	Select group 2.	Select group 3.	Select group 4.
Port configuration	Action 1:	Select <i>Configuration</i> mode			
	Action 2/indication:	Select 9600 baud. <i>Blink:</i> selected	Select 19200 baud. <i>Blink:</i> selected	Select 38400 baud. <i>Blink:</i> selected	Select 115200 baud. <i>Blink:</i> selected
Front panel locks	Action:	With Esc, toggle front panel lock on and off.	Flash twice to indicated the front panel has been locked or unlocked.	With Enter, toggle front panel lock on and off.	

- ③ **Enter button** — The Enter button has three primary functions (•) and four secondary functions (□):
- Save changes that you make on the front panel. To create a simple configuration:
 - Press the desired input button (⓪).
 - Press the desired output button(s) (Ⓜ).
 - Press the Enter button.
 - Indicate that a potential tie has been created but not saved.
 - Indicate that a global preset has been selected to be saved or recalled but that the preset action has not been accomplished.

-
- ❑ In the *I/O Group* mode, select group 1 and indicate its selection. See “*I/O grouping*” on page 3-17.
 - ❑ With the Preset, View, and Esc buttons, select *Serial Port Selection and Configuration* mode. See “*Selecting the rear panel Remote port protocol and baud rate*” on page 3-27.
 - ❑ Select 9600 baud for the RS-232/RS-422 port in *Serial Port Selection and Configuration* mode and indicate its selection. See “*Selecting the rear panel Remote port protocol and baud rate*” on page 3-27.
 - ❑ With the Esc button, toggles the front panel lock on and off. See “*Locking out the front panel (Executive mode)*” on page 3-25.
- ④ **Preset button** — The Preset button has two primary functions (•) and four secondary functions (❑):
- Activates *Save Preset* mode to save a configuration as a preset and *Recall Preset* mode to activate a previously-defined preset.
 - Blinks when *Save Preset* mode is active and lights steadily when *Recall Preset* mode is active.
 - ❑ In the *I/O Group* mode, select group 2 and indicate its selection. See “*I/O grouping*” on page 3-17.
 - ❑ With the Enter, View, and Esc buttons, select *Serial Port Selection and Configuration* mode. See “*Selecting the rear panel Remote port protocol and baud rate*” on page 3-27.
 - ❑ Select 19200 baud for the RS-232/RS-422 port in *Serial Port Selection and Configuration* mode and indicate its selection. See “*Selecting the rear panel Remote port protocol and baud rate*” on page 3-27.
 - ❑ With the View button, indicate that the front panel lock has been toggled on or off. See “*Locking out the front panel (Executive mode)*” on page 3-25.
- ⑤ **View button** — The View button has two primary functions (•) and four secondary functions (❑):
- Select *View-only* mode that displays the current configuration.
- NOTE** *View-only mode also provides a way to mute and unmute the outputs. See “Muting and unmuting outputs” on page 3-23.*
- Indicate that *View-only* mode is active.
 - ❑ In the *I/O Group* mode, select group 3 and indicate its selection. See “*I/O grouping*” on page 3-17.
 - ❑ With the Enter, Preset, and Esc buttons, select *Serial Port Selection and Configuration* mode. See “*Selecting the rear panel Remote port protocol and baud rate*” on page 3-27.
 - ❑ Select 38400 baud for the RS-232/RS-422 port in *Serial Port Selection and Configuration* mode and indicate its selection. See “*Selecting the rear panel Remote port protocol and baud rate*” on page 3-27.
 - ❑ With the Preset button, indicate that the front panel lock has been toggled on or off. See “*Locking out the front panel (Executive mode)*” on page 3-25.

Operation, cont'd

- ⑥ **Esc button** — The Esc button has two primary functions (•) and four secondary functions (□):
- Cancel operations or selections in progress and reset the front panel button indicators.

NOTE *The Esc button does **not** reset the current configuration or any presets.*

- Flashes once to indicate that the escape function has been activated.
- In the *I/O Group* mode, select group 4 and indicate its selection. See “I/O grouping” on page 3-17.
- With the Enter, Preset, and View buttons, select *Serial Port Selection and Configuration* mode. See “Selecting the rear panel Remote port protocol and baud rate” on page 3-27.
- Select 115200 baud for the RS-232/RS-422 port in *Serial Port Selection and Configuration* mode and indicate its selection. See “Selecting the rear panel Remote port protocol and baud rate” on page 3-27.
- With the Enter button, toggles the front panel lock on and off. See “Locking out the front panel (*Executive mode*)” on page 3-25.

Power indicators

- ⑦ **Primary and Redundant Power Supply LEDs** —

Green — Indicates that the associated power supply is operating within normal tolerances.

Red — Indicates that the associated power supply is operating outside the normal tolerances or has failed. See chapter 7, “Maintenance and Modifications”, to replace the power supply.

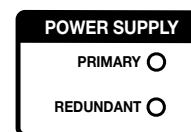

Button labels

The numbered translucent covers on the input and output pushbuttons can be removed and replaced to insert labels behind them.

Input and output labels can be created easily with Extron’s Button-Label Generator software, which ships with every Extron matrix switcher. Each input and output can be labeled with names, alphanumeric characters, or even color bitmaps for easy and intuitive input and output selection (figure 3-2). See chapter 5, “Matrix Software”, for details on using the labeling software. See chapter 7, “Maintenance and Modifications”, for blank labels and a procedure for removing and replacing the translucent covers.

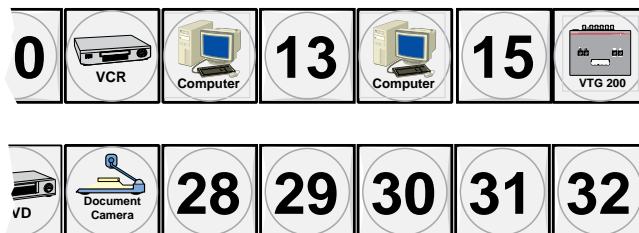

Figure 3-2 — Sample button labels and icons

Rear Panel Power Indicators

The two power supply modules (primary power supply and redundant power supply, figure 3-3) each have a 2-color LED.

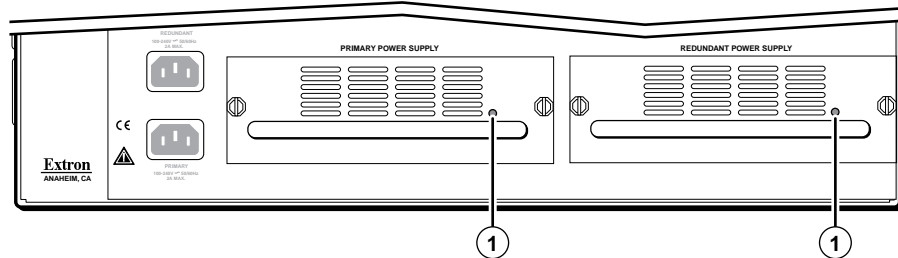

Figure 3-3 — Rear panel power supply indicators

① **Primary and Redundant Power Supply LEDs —**

Green — Indicates that the associated power supply is operating within normal tolerances.

Red — Indicates that the associated power supply has failed. See chapter 7, “Maintenance and Modifications”, to replace the power supply.

Front Panel Operations

The following paragraphs detail the power-up process and then provide sample procedures for the following actions:

- Creating ties, sets of ties, and configurations
- Changing a configuration
- Viewing ties, sets of ties, and configurations
- Creating I/O groups
- Saving a preset
- Recalling a preset
- Muting and unmuting outputs
- Locking and unlocking the front panel
- Performing front panel resets
- Reading and setting the RS-232/RS-422 Remote port settings

Operation, cont'd

Definitions

The following terms, which apply to Extron matrix switchers, are used throughout this manual:

Tie — An input-to-output connection.

Set of ties — An input **typed** to two or more outputs. (An output can never be tied to more than one input.)

Configuration — One or more **ties** or one or more **sets of ties**.

Current configuration — The **configuration** that is currently active in the switcher (also called **configuration 0**)

Global memory preset — A **configuration** that has been stored. Up to 64 **global memory presets** can be stored in memory. When a **preset** is retrieved from memory, it becomes the **current configuration**. Presets can be saved and recalled from the front panel and any of the serial or LAN ports. For front panel operations, preset locations are assigned to the input buttons.

Room — A subset of outputs that are logically related to each other, as determined by the operator. The switchers support up to 10 **rooms**, each of which can consist of from 1 to 16 outputs.

Room memory preset — A **configuration** consisting of outputs in a single **room** that has been stored. When a **room preset** is retrieved from memory, it becomes the **current configuration**.

Power

Apply power by connecting one or both power cords (Primary and Redundant) to the AC source(s). The switcher performs a self-test that flashes the front panel button indicators red, green, red, and amber and then turns them either off or to background illumination. An error-free power up self-test sequence leaves all control buttons either unlit or showing background illumination.

The current configuration and all presets are saved in non-volatile memory. When power is applied, the most recent configuration is retrieved. The previous presets remain intact.

If an error occurs during the self-test, the switcher locks up. If your switcher locks up on power-up, call the Extron S³ Sales & Technical Support Hotline. See the rear cover of this manual for the phone number in your region of the world.

Creating a configuration

The current configuration can be changed using the front panel buttons. Change the current configuration as follows:

1. Press the Esc button to clear any front panel button indications that may be lit.
2. Select the desired input and output(s) by pressing the input and output buttons. Input buttons and output buttons light or blink green to indicate ties.
 - To indicate **potential ties**, output buttons **blink** when an input is selected.
 - To indicate **current ties**, output buttons **light steadily** when an input is selected.
 - To clear unwanted outputs, press and release the associated lit output buttons. To indicate **potential unties**, output buttons **blink** when an output is deselected but not untied from the input.
3. Press and release the Enter button to accept the tie.
4. Repeat steps 1 through 3 to create or delete additional ties until the desired configuration is complete.

NOTE

- *Only one input can be tied to an output.*
- *If a tie is made between an input and an output, and the selected output was previously tied to another input, the older tie is broken in favor of the newer tie.*
- *If an input with no tie is selected, only that input's button lights.*
- *As each input and output is selected, the associated output button blinks to indicate a tentative tie. Buttons for output(s) that were already tied to the input light steadily. Outputs that are already tied can be left on, along with new blinking selections, or toggled off by pressing the associated output button.*
- *If you press the input button for an I/O grouped input and then try to select an output in a different group, you cannot select the associated output button. The associated input button remains lit.*
- *An optical input can be tied to optical and/or SDI/HD-SDI outputs, and an SDI/HD-SDI input can be tied to SDI/HD-SDI and/or optical outputs.*

Operation, cont'd

Example 1: Creating a set of ties

In the following example, input 5 is tied to outputs 3, 4, and 8. The steps show the front panel indications that result from your action.

NOTE This example assumes that there are no ties in the current configuration.

1. **Clear all selections:** Press and release the Esc button.

Press the Esc button to clear all selections.

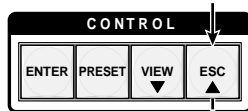

The button flashes once.

2. **Select an input:** Press and release the Input 5 button.

Press and release the Input 5 button.
The button lights.

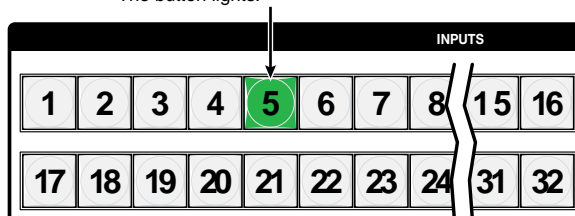

3. **Select the outputs:** Press and release the Output 3, Output 4, and Output 8 buttons.

Press and release the Output 3, Output 4, and Output 8 buttons.
The buttons blink to indicate that the selected input will be tied to these outputs.

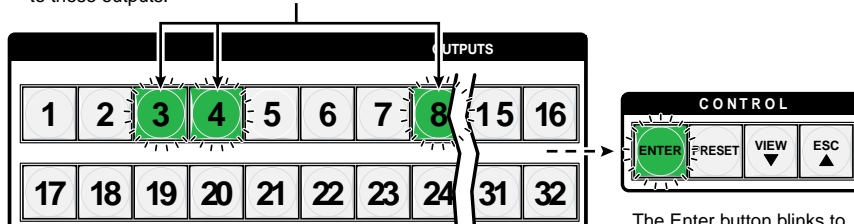

The Enter button blinks to indicate the need to confirm the change.

NOTE You can cancel the entire set of ties up to this point by pressing and releasing the Esc button. The Esc button flashes once.

4. **Confirm the change:** Press and release the Enter button.

Press the Enter button to confirm the configuration change.



All input buttons and output buttons return to unlit or background illumination.

The Enter button returns to unlit or background illumination.

The current configuration is now input 5 tied to output 3, output 4, and output 8.

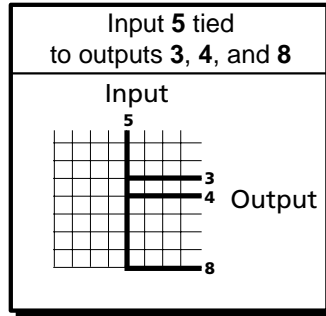

Example 2: Adding a tie to a set of ties

In the following example, a new tie is added to the current configuration. The steps show the front panel indications that result from your action.

NOTE This example assumes that you have performed example 1.

1. **Clear all selections:** Press and release the Esc button.

Press the Esc button to clear all selections.

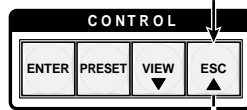

The button flashes once.

2. **Select an input:** Press and release the Input 5 button.

Press and release the Input 5 button.
The button lights.

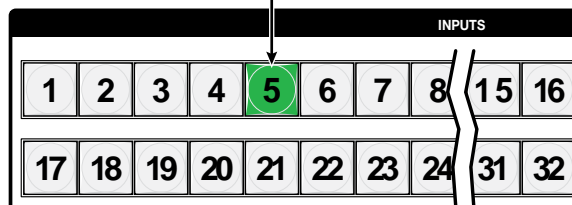

The Output 3, Output 4, and Output 8 buttons light to indicate the ties created in example 1.

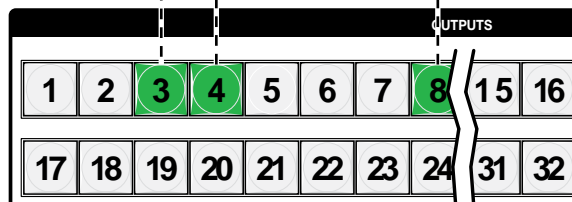

Operation, cont'd

3. **Select the output:** Press and release the Output 1 button.

Press and release the Output 1 button.
The button blinks to indicate that the selected input will be tied to this output.

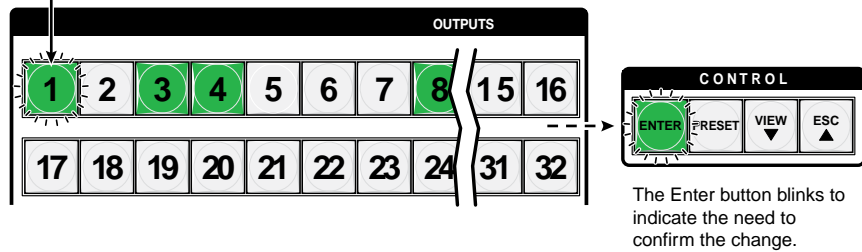

4. **Confirm the change:** Press and release the Enter button.

Press the Enter button to confirm the configuration change.

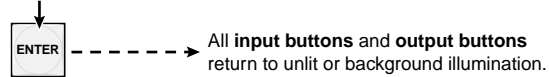

The Enter button returns to unlit or background illumination.

The current configuration is now input 5 tied to Output 1, Output 3, Output 4, and output 8.

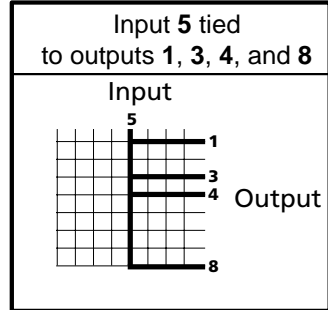

Example 3: Removing a tie from a set of ties

In the following example, an existing tie is removed from the current configuration. The steps show the front panel indications that result from your action.

NOTE This example assumes that you have performed example 1 and example 2.

1. **Clear all selections:** Press and release the Esc button.

Press the Esc button to clear all selections.

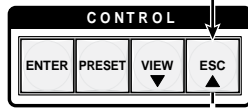

The button flashes once.

2. **Select an input:** Press and release the Input 5 button.

Press and release the Input 5 button.
The button lights.

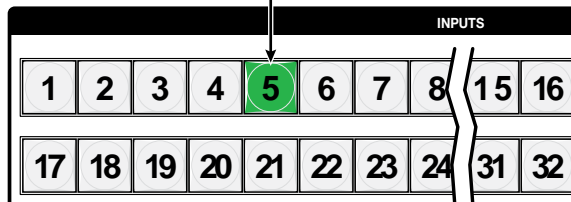

The Output 1, Output 3, Output 4, and Output 8 buttons light to indicate the ties created in example 1 and example 2.

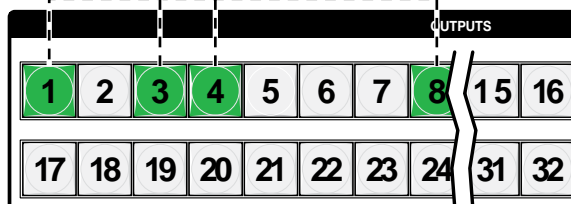

3. **Select the output:** Press and release the Output 4 button.

Press and release the Output 4 button.
The button blinks to indicate that the selected input will be untied from this output.

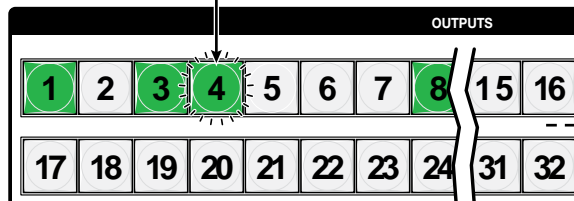

The Enter button blinks to indicate the need to confirm the change.

Operation, cont'd

4. **Confirm the change:** Press and release the Enter button.

Press the Enter button to confirm the configuration change.

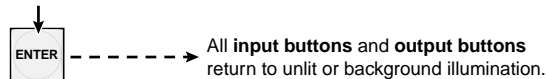

The Enter button returns to unlit or background illumination.

The current configuration is now input 5 tied to output 1, output 3, and output 8.

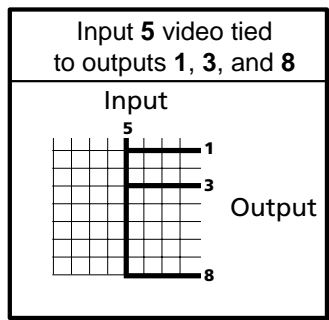

Viewing a configuration

The current configuration can be viewed using the front panel buttons. The *View-only* mode prevents inadvertent changes to the current configuration. *View-only* mode also provides a way to mute outputs (see "Muting and unmuting outputs" on page 3-23).

View the current configuration as follows:

1. Press the Esc button to clear any front panel button indications that may be on.
2. Press and release the View button. All of the buttons light for outputs that are **not** tied
3. Select the desired input or output(s) whose ties you wish to view by pressing the input and output buttons.

- NOTE**
- When you enter View-only mode, the output buttons light for all outputs without ties. Likewise, when you press an output button for which there are no ties, the output buttons light for all outputs without ties.
 - To see all ties of the current configuration, press and release each input and output button, one at a time.
 - After 30 seconds of front panel inactivity, View-only mode automatically ends.

Example 4: Viewing ties

In the following example, the ties in the current configuration are viewed. The steps show the front panel indications that result from your action.

NOTE This example assumes that you have performed example 1, example 2, and example 3.

1. **Clear all selections:** Press and release the Esc button.

Press the Esc button to clear all selections.

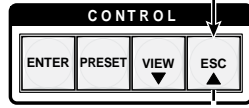

The button flashes once.

2. **Select View-only mode:** Press and release the View button to enter *View-only* mode.

Press the View button.

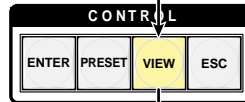

The button lights.

Until you select an input, **only** the buttons for **untied** outputs light.

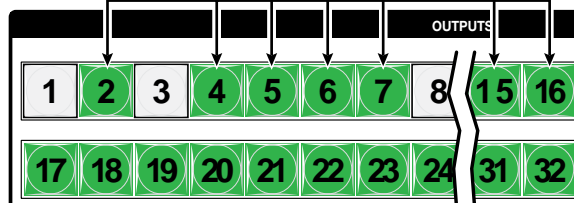

Operation, cont'd

3. **Select an input:** Press and release the Input 5 button.

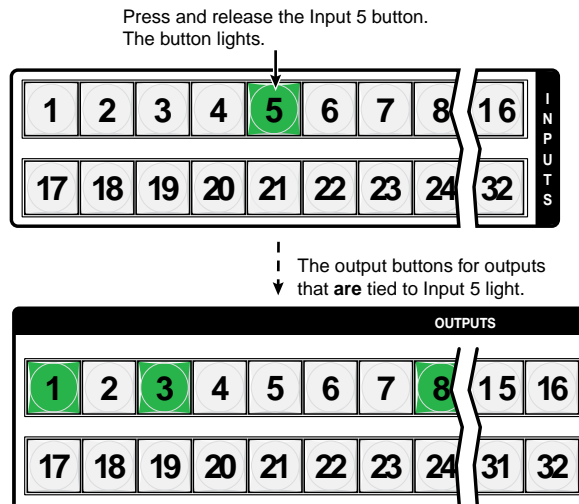

The output buttons for outputs that are **not** tied to Input 5 are either unlit or background illuminated.

NOTE You can also view a set of ties by selecting a tied output. For example, note the number of a lit output button, and then press and release the output button for an untied (unlit or background illumination) output. Observe that all of the untied outputs light. Then press the output button that you noted previously and observe that the selected output button, the tied input button (input 5), and the output buttons light for all of the outputs that are tied to the input.

4. **Exit View-only mode:** Press and release the View button to exit View-only mode.

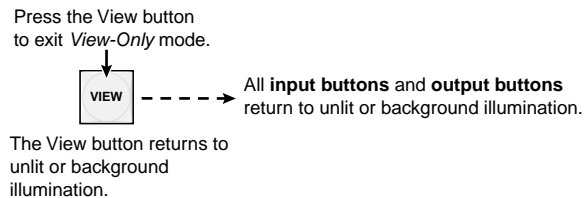

I/O grouping

I/O grouping is a matrix switcher feature that allows you to subdivide the front panel controls of the matrix into up to four smaller functional sub-switchers (figure 3-4) and limit tie creation **from the front panel only**. Inputs and outputs can be assigned to one of four groups or not assigned to any group.

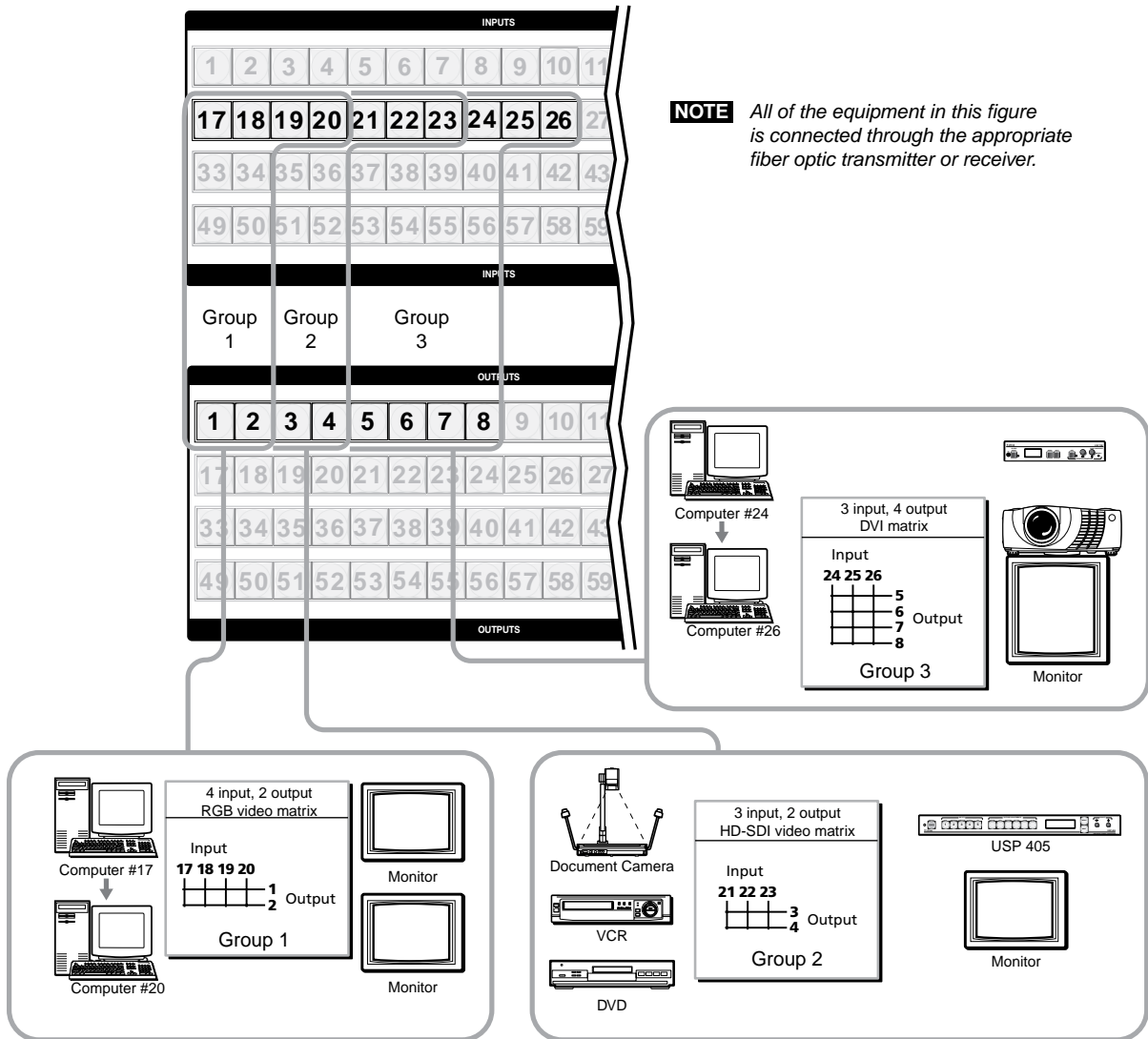

Figure 3-4 — I/O grouping of incompatible video formats

When you are creating ties on the front panel, inputs and outputs that are assigned to a group can be tied only to other outputs and inputs within the same group. For example, a front panel operator cannot tie an input that is assigned to group 1 to an output that is assigned to group 2. Ungrouped inputs and outputs can be switched to outputs and inputs in any group. Ties between groups (an input in group 1 tied to an output in group 2) can be created under RS-232/RS-422 or Ethernet control.

Operation, cont'd

Suggested applications for the I/O grouping feature include:

- Segregating specific video formats to prevent an input in one video format from being inadvertently applied to an output device that supports another video format
- Segregating input and output devices that are in separate rooms
- Segregating incompatible fiber signals, such as those from a FOX 500 system and those from a FOX HD-SDI system
- Isolating video from being displayed on specific output devices for operational security reasons

The I/O groups can be set up on the front panel or by using either serial port and/or the LAN port and either the SIS or the Windows control program (see chapter 4, "Programmer's Guide", and chapter 5, "Matrix Software").

Create I/O groups on the front panel as follows:

1. Press the Esc button to clear any front panel button indications that may be lit.
2. To enter *I/O Group* mode, press and **hold** the Input 1 and Output 1 buttons until the input and output buttons light to display the ungrouped inputs and outputs.
3. Press and release one of the Control buttons to select a group:
 - Press the Enter button to select group 1.
 - Press the Preset button to select group 2.
 - Press the View button to select group 3.
 - Press the Esc button to select group 4.
4. Select the desired input(s) and output(s) to assign to the group by pressing the input and output buttons.
5. Allow the *I/O Group* mode to time out after approximately 30 seconds.

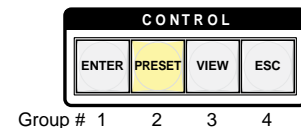

- NOTE**
- *Ties between groups (an input in group 1 tied to an output in group 2) can be created under either serial port or Ethernet control.*
 - *Ties that were created before I/O groups were created remain valid, even if they include inputs and outputs in different groups.*
 - *Presets can be created under serial port or Ethernet control that tie inputs and outputs across group boundaries. These presets **are** selectable from the front panel.*
 - *An input or output can be assigned to only one group. If you assign an input or output to a group and that input or output is already assigned to a different group, the older grouping is discarded in favor of the new grouping.*
 - *For I/O groups to have any function, at least two groups must be created.*

Example 5: Grouping inputs and outputs

In the following example, several switcher inputs and outputs are assigned to groups. The steps show the front panel indications that result from your action.

1. **Clear all selections:** Press and release the Esc button.

Press the Esc button to clear all selections.

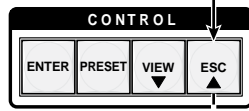

The button flashes once.

2. **Select I/O Group mode:** Press and **hold** the Input 1 and Output 1 buttons for approximately 2 seconds and then release the buttons.

Press and **hold** the Input 1 button and Output 1 button.

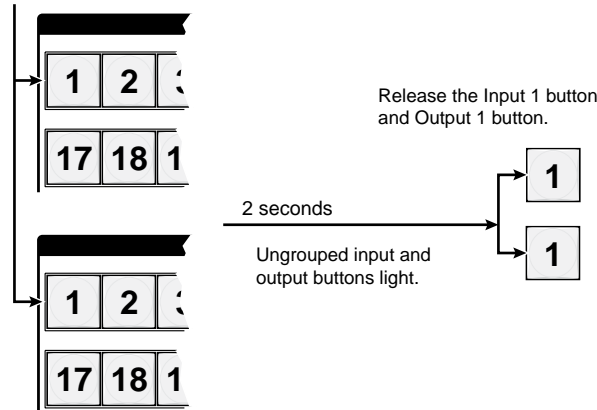

3. **Select an I/O group:** Press and release the Enter button to select group 1.

Press and release the Enter button to select group 1.
The button lights to indicate the selection.

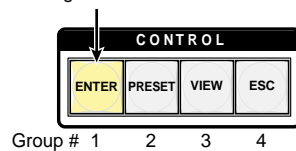

Operation, cont'd

4. **Assign inputs and outputs:** Press and release the input 1 through 4 and output 1 through 4 buttons.

Press and release the Input 1 through Input 4 buttons.
The selected buttons light.

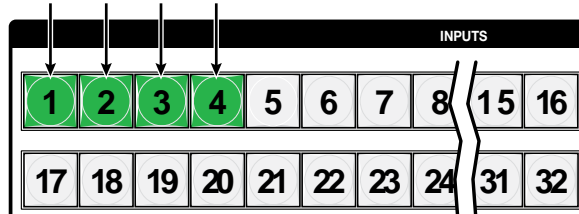

Press and release the Output 1 through Output 4 buttons.
The selected buttons light.

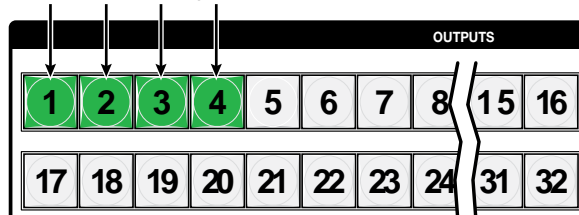

5. **Select an I/O group:** Press and release the Preset button to select group 2.

Press and release the Preset button to select group 2.
The button lights to indicate the selection.

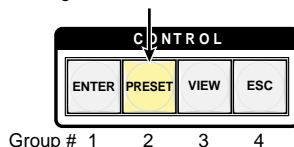

6. **Assign inputs and outputs:** Press and release the input 5 through 8 and output 5 through 8 buttons.

Press and release the Input 5 through Input 6 buttons.
The selected buttons light.

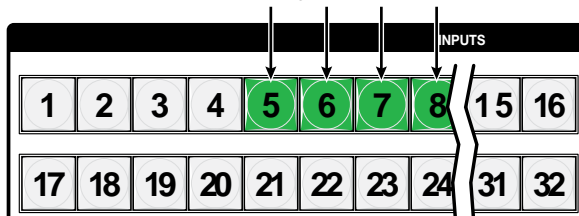

Press and release the Output 5 through Output 8 buttons.
The selected buttons light.

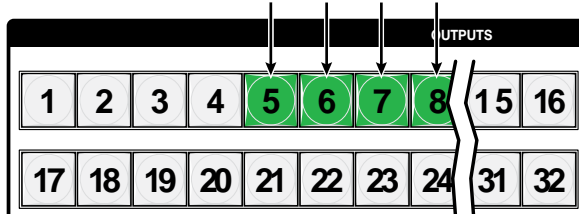

7. Do nothing for approximately 30 seconds. The switcher exits *I/O Group* mode.
 - Group 1 consists of inputs 1 through 4 and outputs 1 through 4.
 - Group 2 consists of inputs 5 through 8 and outputs 5 through 8.

Using presets

The current configuration (configuration 0) can be saved as a preset in any one of 64 preset memory addresses. Presets can be saved and recalled from the front panel. The preset locations are assigned to input buttons 1 through 64. When a preset is retrieved from memory, it becomes the **current configuration**.

- NOTE**
- Presets *cannot* be viewed from the front panel unless recalled as the current configuration. Presets *can* be viewed using Extron's Windows-based control program. See chapter 5, "Matrix Software", for more details.
 - The current configuration and all presets are stored in non-volatile memory. When power is removed and restored, the current configuration is still active and all presets are retained.
 - When a preset is recalled, it replaces the current configuration, which is lost unless it is also stored as a preset. The recalled preset overwrites all of the current configuration ties in favor of the preset configuration ties.

Example 6: Saving a preset

In the following example, the current configuration is saved as a preset. The steps show the front panel indications that result from your action.

1. **Clear all selections:** Press and release the Esc button.

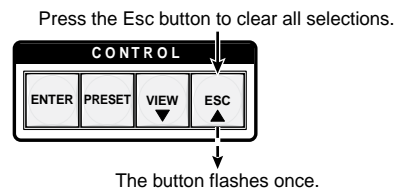

2. **Select Save Preset mode:** Press and **hold** the Preset button for approximately 2 seconds until it blinks.

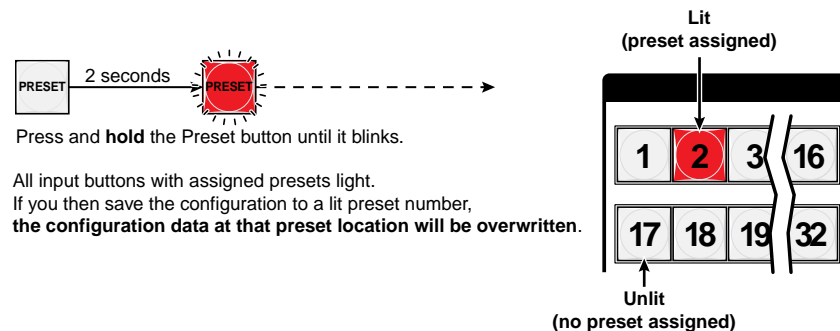

3. **Select the preset:** Press and release the input button for the desired preset.

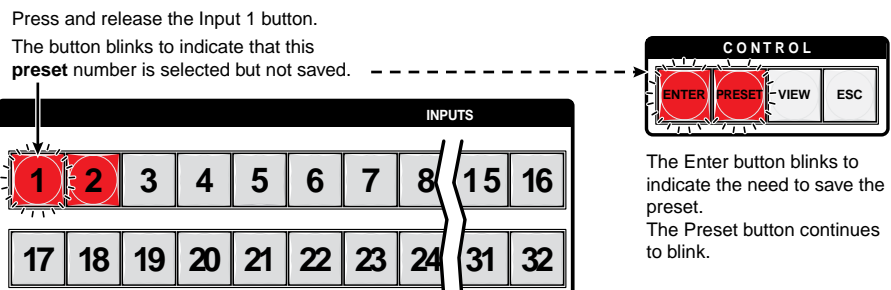

Operation, cont'd

4. **Confirm the change:** Press and release the Enter button. The current configuration is now stored in the selected memory location.

Press the Enter button to save the preset.

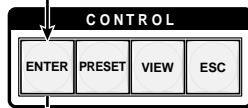

The Enter and Preset buttons return to unlit or background illumination.

All input buttons and output buttons return to unlit or background illumination.

Example 7: Recalling a preset

In the following example, a preset is recalled to become the current configuration. The steps show the front panel indications that result from your action.

1. **Clear all selections:** Press and release the Esc button.

Press the Esc button to clear all selections.

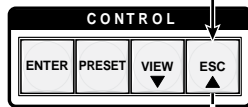

The button flashes once.

2. **Select Recall Preset mode:** Press and release the Preset button.

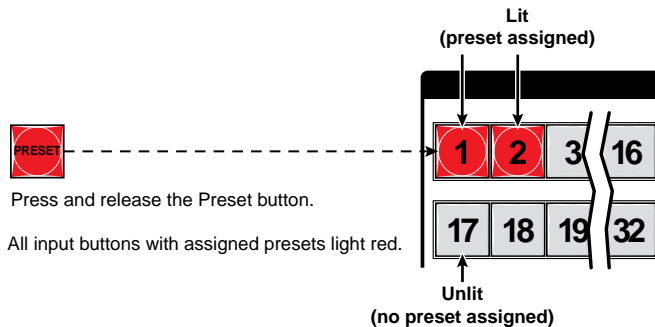

3. **Select the preset:** Press and release the input button for the desired preset.

Press and release the Input 1 button.

The button blinks to indicate that this preset number is selected but not recalled.

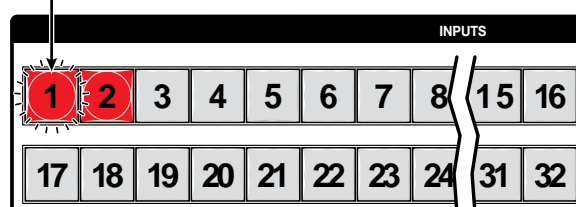

The Enter button blinks to indicate the need to save the preset.

-
4. **Confirm the change:** Press and release the Enter button. The configuration stored in the selected memory location is now the current configuration and can be viewed in the *View-only* mode (see example 4).

Press the Enter button to recall the preset.

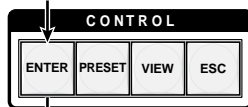

The Enter and Preset buttons return to unlit or background illumination.

All input buttons and output buttons return to unlit or background illumination.

Muting and unmuting outputs

Individual outputs can be muted or unmuted as follows:

1. Press the Esc button to clear any front panel button indications that may be on.
2. Press and release the View button.
3. One at a time, press and **hold** the button(s) for the desired output(s) for approximately 2 seconds. The output button(s) for the selected output(s) blink to indicate the mute or return to their previous state to indicate the unmute.
4. Press and release the View button to return to normal switcher operation.

- NOTE**
- When you enter View-only mode, the output buttons light for all outputs *without ties*.
 - Mutes are saved to non-volatile memory. When power is removed and restored, the mute settings are retained.

Operation, cont'd

Example 9: Muting and unmuting an output

In the following example, several switcher outputs are muted and unmuted. The steps show the front panel indications that result from your action.

1. **Clear all selections:** Press and release the Esc button.

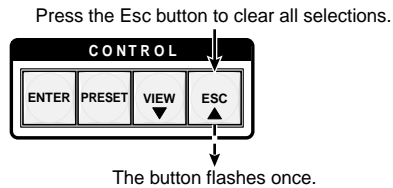

2. **Select *View-only* mode:** Press and release the View button to enter *View-only* mode. The View button lights.

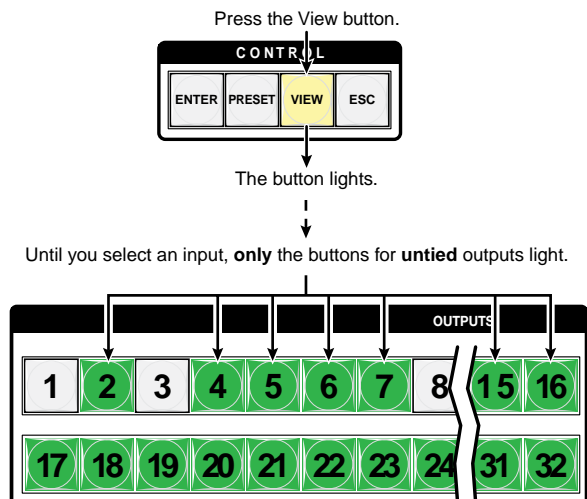

3. **Mute the outputs:** **One at a time**, press and **hold** the Output 3 button for approximately 2 seconds until it begins to blink and then the Output 4 button. The output 3 and output 4 signals are muted.

Mute outputs one at a time.

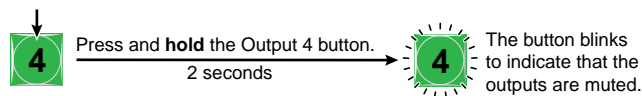
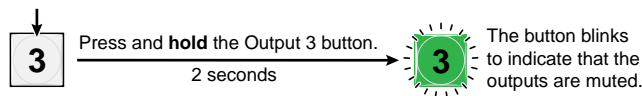

NOTE When you push Input 3, it lights and Input 4 returns to unlit because of ties made in examples 1, 2, and 3.

4. **Unmute the outputs:**One at a time, press and **hold** the Output 3 button for approximately 2 seconds until it lights steadily and then the Output 4 button. The output 3 and output 4 signals are unmuted.

Unmute outputs one at a time.

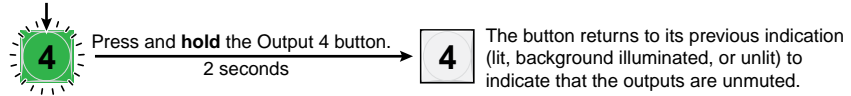
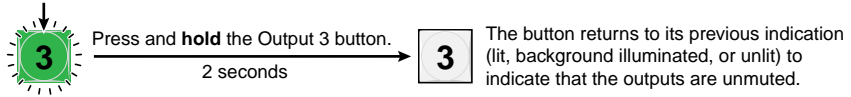

5. **Exit *View-only* mode:** Press and release the View button to exit *View-only* mode.

Press the View button to exit *View-Only* mode.

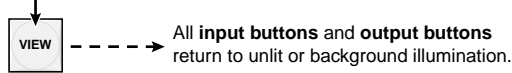

The View button returns to unlit or background illumination.

Locking out the front panel (*Executive mode*)

The front panel security lockout limits the operation of the switcher from the front panel. When the switcher is locked, all of the front panel functions are disabled except for the *View-Only* mode functions and selecting among the front panel *Lock* modes. See “Viewing a configuration” on page 3-14. Other than in *View-Only* mode, if the user pushes a front panel button when the switcher is locked, the View and Preset buttons flash twice and return to their previous state.

To toggle the lock on and off, press and hold the Enter button and the Esc button for approximately two seconds.

Press and **hold** the Enter and Esc buttons simultaneously to toggle executive mode on or off.

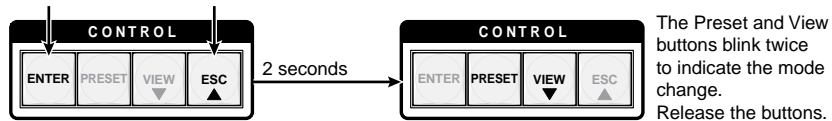

Operation, cont'd

Performing a system reset from the front panel

The front panel reset is identical to the **Esc**ZXXX← SIS command (see chapter 4, “Programmer’s Guide”). A system reset clears all ties and presets, all output mutes, and resets all I/O grouping.

Reset the switcher to the factory default settings by pressing and **holding** the View button and Esc button **while** you apply AC power to the switcher.

NOTE You must apply power from an unpowered state. Applying the redundant power with primary power already applied does **not** reset the switcher.

System reset does not reset the Internet protocol (IP) settings or replace user-installed firmware.

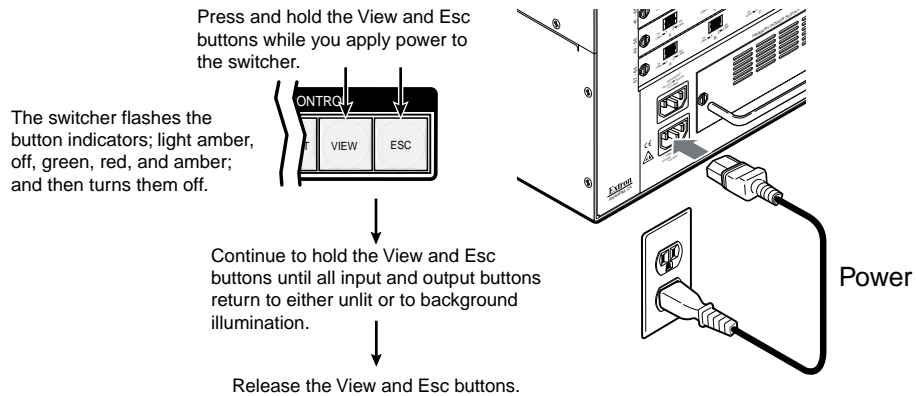

Background illumination

The buttons on the front panel can be set to provide amber background illumination at all times or the background illumination can be turned off. To toggle the background illumination on or off, press and hold the Input 1 and Input 2 buttons simultaneously for approximately 2 seconds.

Press and **hold** the Input 1 and Input 2 buttons simultaneously for approximately 2 seconds to toggle background illumination mode on or off.

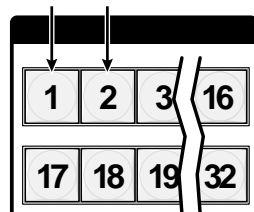

Release the Input 1 and Input 2 buttons.

Selecting the rear panel Remote port protocol and baud rate

The switcher can support either RS-232 or RS-422 serial communication protocol, and can operate at 9600, 19200, 38400, and 115200 baud rates. The settings of these variables can be viewed and changed from the front panel.

View and configure the switcher's serial communications settings as follows:

1. **Select *Serial Port Selection and Configuration mode*:** Simultaneously press and hold all Control buttons (Enter, Preset, View, and Esc).

Press and hold the Enter, Preset, View, and Esc buttons.

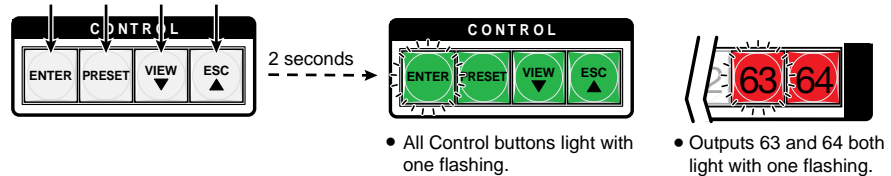

The flashing Control button indicates the **baud rate** as follows:

Enter — 9600	Preset — 19200
View — 38400	Esc — 115200

The flashing output button indicates the **protocol** as follows:

Output 63 — RS-232	Output 64 — RS-422
--------------------	--------------------

In this example, the port is set to RS-232 at 9600 baud.

2. Release the Control buttons.
3. **Change a value:** Press and release the button that relates to the desired value.

Press and release the button(s) to configure the port as follows:

Baud rate:

Enter — 9600	Preset — 19200
View — 38400	Esc — 115200

Serial protocol:

Output 63 — RS-232	Output 64 — RS-422
--------------------	--------------------

The selected buttons blink and the others remain lit.

In this example, the port is set to RS-422 at 38400 baud.

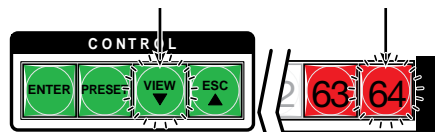

4. **Exit *Serial Port Selection and Configuration mode*:** Press and release an output button.

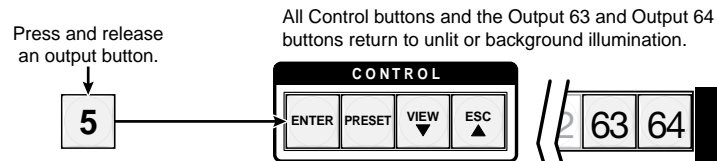

Operation, cont'd

Rear Panel Operations

The rear panel has a Reset button that initiates four levels of resets (numbered 1, 3, 4, and 5 for the sake of comparison with an Extron IPL product). The Reset button is recessed, so use a pointed stylus, ballpoint pen, or Extron Tweeker to access it.

See the following table for a summary of the modes.

CAUTION Review the reset modes carefully. Using the wrong reset mode may result in unintended loss of flash memory programming, port reassignment, or a controller reboot.

NOTE The reset modes listed below close all open IP and Telnet connections and close all sockets. Also, the following modes are separate functions, not a continuation from Mode 1 to Mode 5.

Reset Mode Comparison/Summary			
Mode	Activation	Result	Purpose/Notes
1	Hold down the recessed Reset button while applying power to the switcher. NOTE After a mode 1 reset is performed, update the switcher's firmware to the latest version. Do not operate the switcher firmware version that results from the mode 1 reset. If you want to use the factory default firmware, you must upload that version again. See chapter 5, "Matrix Software", for details on uploading firmware.	The switcher reverts to the factory default firmware. Event scripting will not start if the switcher is powered on in this mode. All user files and settings, such as IP settings, are maintained. NOTE If you do not want to update firmware, or you performed a mode 1 reset by mistake, cycle power to the switcher to return to the firmware version that was running before the mode 1 reset. Use the 0Q SIS command to confirm that the factory default firmware is no longer running (look for the asterisk [*] following the version number.	Use mode 1 to revert to the factory default firmware version if incompatibility issues arise with user-loaded firmware.
3	Hold down the Reset button for about 3 seconds, until the Reset LED blinks once, then press Reset momentarily (<1 second) within 1 second.	Mode 3 turns events on or off. During resetting, the Reset LED flashes 2 times if events are starting, 3 times if events are stopping.	Mode 3 is useful for troubleshooting.
4	Hold down the Reset button for about 6 seconds, until the Reset LED blinks twice (once at 3 seconds and again at 6 seconds). Then press Reset momentarily (<1 second) within 1 second.	Mode 4: <ul style="list-style-type: none"> • Enables address resolution protocol (ARP) capability. • Sets the IP address to the factory default. • Sets the subnet address to the factory default. • Sets the gateway address to the factory default. • Sets port mapping to the factory default. • Turns DHCP off. • Turn events off. The Reset LED flashes three times in quick succession during the reset.	Mode 4 enables you to set IP address information using ARP and the MAC address.
5	Hold down the Reset button for about 9 seconds, until the Reset LED blinks three times (once at 3 seconds, again at 6 seconds, and then again at 9 seconds). Then press Reset momentarily (<1 second) within 1 second.	Mode 5 performs a complete reset to factory defaults (with the exception of the firmware): <ul style="list-style-type: none"> • Does everything mode 4 does. • Resets most settings including: <ul style="list-style-type: none"> clears all ties and presets clears all output mutes clears all I/O grouping • Resets all IP options. • Removes/clears all files for the switcher. The reset LED flashes three times in quick succession during the reset.	Mode 5 is useful if you want to start over with configuration and uploading or to replace events. Same as <code>Esc/ZXXX←</code> SIS command, see chapter 4, "Programmer's Guide".

Performing soft system resets (resets 3, 4, and 5)

Perform a soft reset of the switcher as follows:

1. Use an Extron Tweezer or other small screwdriver to press and **hold** the rear panel Reset button until the rear panel Reset LED and the front panel View and Esc buttons blink once (events reset), twice (system reset), or three times (absolute reset).

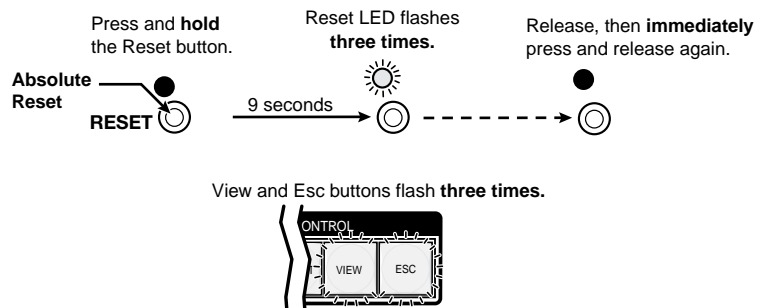
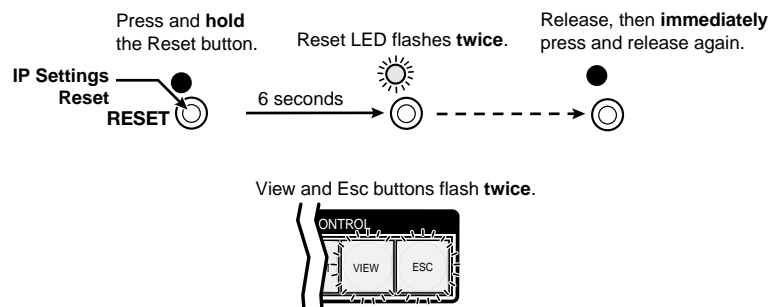
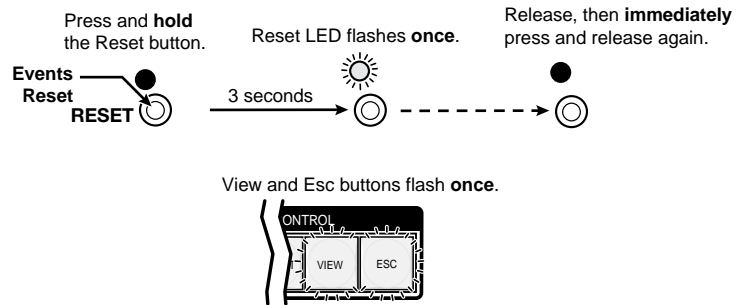

2. Release the Reset button and then immediately press and release the Reset button again. Nothing happens if the second momentary press does not occur within 1 second.

Operation, cont'd

Performing a hard reset (reset 1)

The hard reset function restores the switcher to the base firmware that it was shipped with. After a hard reset, events do not automatically start, but user settings and files are restored. Perform a hard reset as follows:

NOTE *The hard reset restores the factory-installed firmware. The switcher reverts to that factory firmware the next time power is cycled off and on unless a firmware update is performed before the power cycle.*

1. If necessary, turn off power to the switcher.
2. Press and **hold** the Reset button on the rear panel **while** you apply AC power to the switcher.

Press and **hold** the Reset button while you apply power to the switcher.



The switcher flashes the button indicators light amber, off, green, red, and amber and then turns them off.



Continue to hold the Reset button until all input and output buttons are either unlit or return to background illumination.



Release the Reset button.

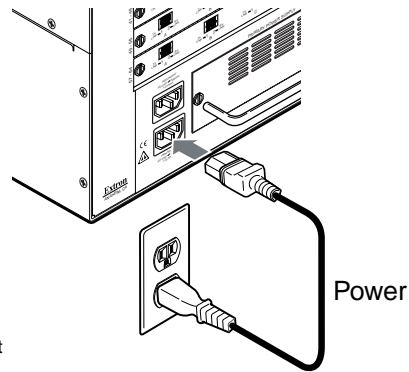

Troubleshooting

This section gives recommendations on what to do if you have problems operating the switcher.

1. Ensure that all devices are plugged in and powered on. The switcher is receiving power if one of the front panel Power Supply LEDs is lit green.
2. Check to see if one or more outputs are muted.
3. Ensure an active input is selected for output on the switcher.
4. Ensure that the proper signal format is supplied.
5. Check the cabling and make corrections as necessary.
6. Call the Extron S³ Sales & Technical Support Hotline if necessary. See the rear cover of this manual for the phone number in your region of the world.

Configuration Worksheets

Rather than trying to remember the configuration for each preset, use worksheets to record this information. Make copies of the blank worksheet on page 3-38 and use one for each preset configuration. Cross out all unused or inactive inputs and outputs..

NOTE *All of the equipment in the following examples is connected through the appropriate fiber optic transmitter or receiver.*

Worksheet example 1: System equipment

Figure 3-5 shows a worksheet for a 48-input by 32-output Fiber Matrix in a fictional organization with the system hardware annotated. Inputs 10, 11, 25, 30, 35, 40, and 45 through 48 have no connections in this organization, so they have been crossed out on the worksheet. Inputs 49 through 64 do not exist on this model, so they are crossed out. Similarly, outputs 7, 14, 15, 16, and 33 through 64 are crossed out on the worksheet.

Inputs include PCs, an audio CD player, cameras, and an Extron VTG 400D. Output devices include monitors, front and rear projectors, a stereo, and a VCR for recording presentations.

The VTG 400D video test generator connected to input 12 enables a video test pattern to be sent to one, several, or all output devices for problem isolation or adjustment purposes. An audio test tape or CD could be used in a similar manner to check the audio components.

Operation, cont'd

Worksheet example 2: Daily configuration

Figure 3-6 continues from worksheet example 1 by showing the ties that make up the configuration of preset 1. Black lines shows one configuration, green lines a second configuration, and red lines a third configuration.

In this example:

- The image of the presenter, from the main podium camera (input 1), is:
 - Displayed in the main hall (output 1)
 - Displayed in the conference room (output 4) to the overflow crowd
 - Displayed in the lobby (output 8)
 - Tied to the VCR (output 6)
- The presenter has a presentation on her laptop computer (input 4) that is:
 - Displayed in the main hall (output 2)
 - Displayed locally on the podium (output 3)
- Music from the CD player (input 5) is:
 - Played in the background in the main hall on sound system #2 (output 5)
 - Played in the lobby (output 8)

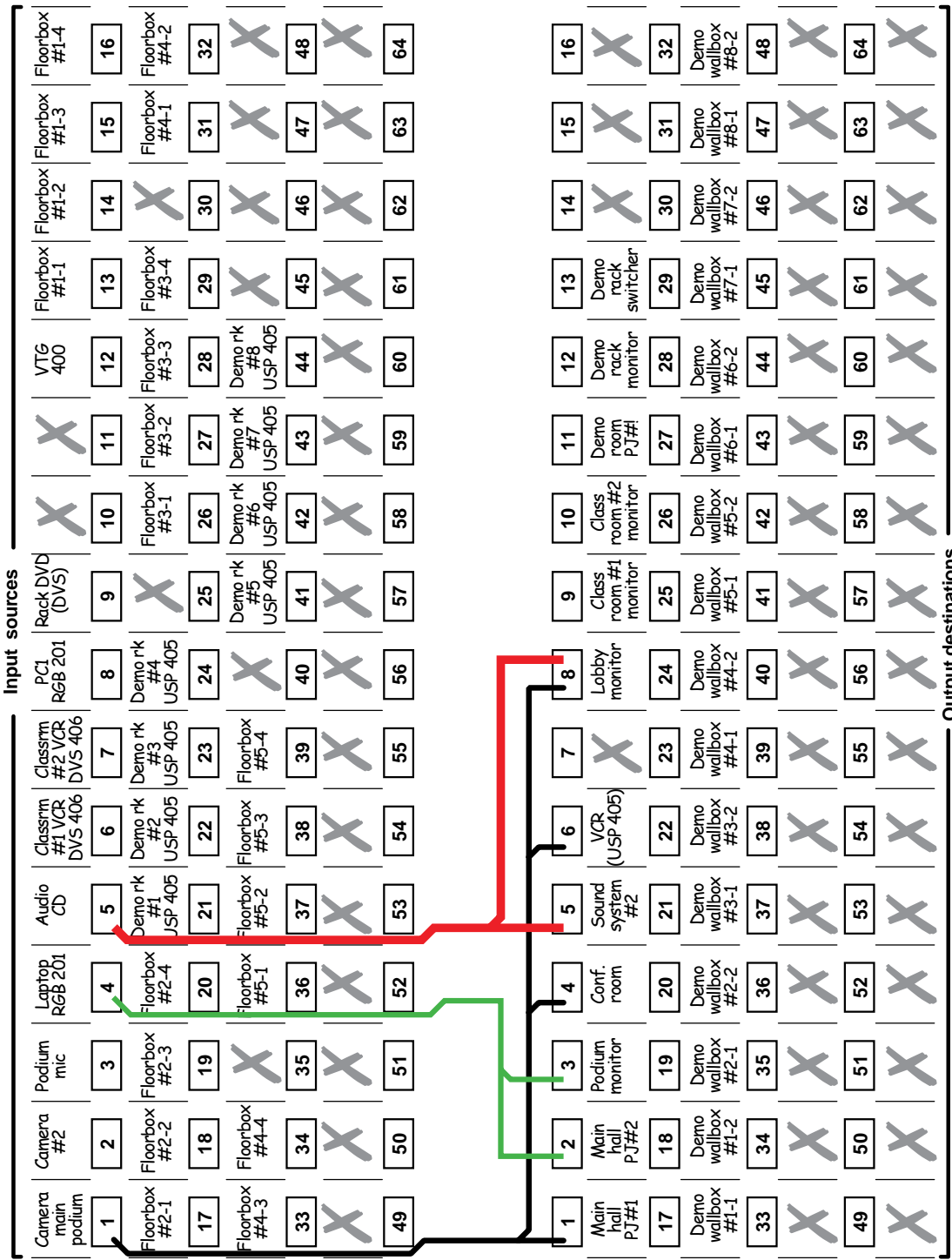

Preset # _____ Title: _____
 Fill in the preset number and use colors, or dashes, etc. to make connecting lines.

Figure 3-6 — Worksheet example 2: Daily configuration

Operation, cont'd

Worksheet example 3: Test configuration

The A/V system in our fictional organization needs to be fine tuned on a regular basis. Figure 3-7 shows a typical test configuration, with an Extron video test generator (input 12) generating a test pattern to all monitors (outputs 1, 2, 3, 4, 8, 9, 10, 11, and 12) and to the various wall boxes.

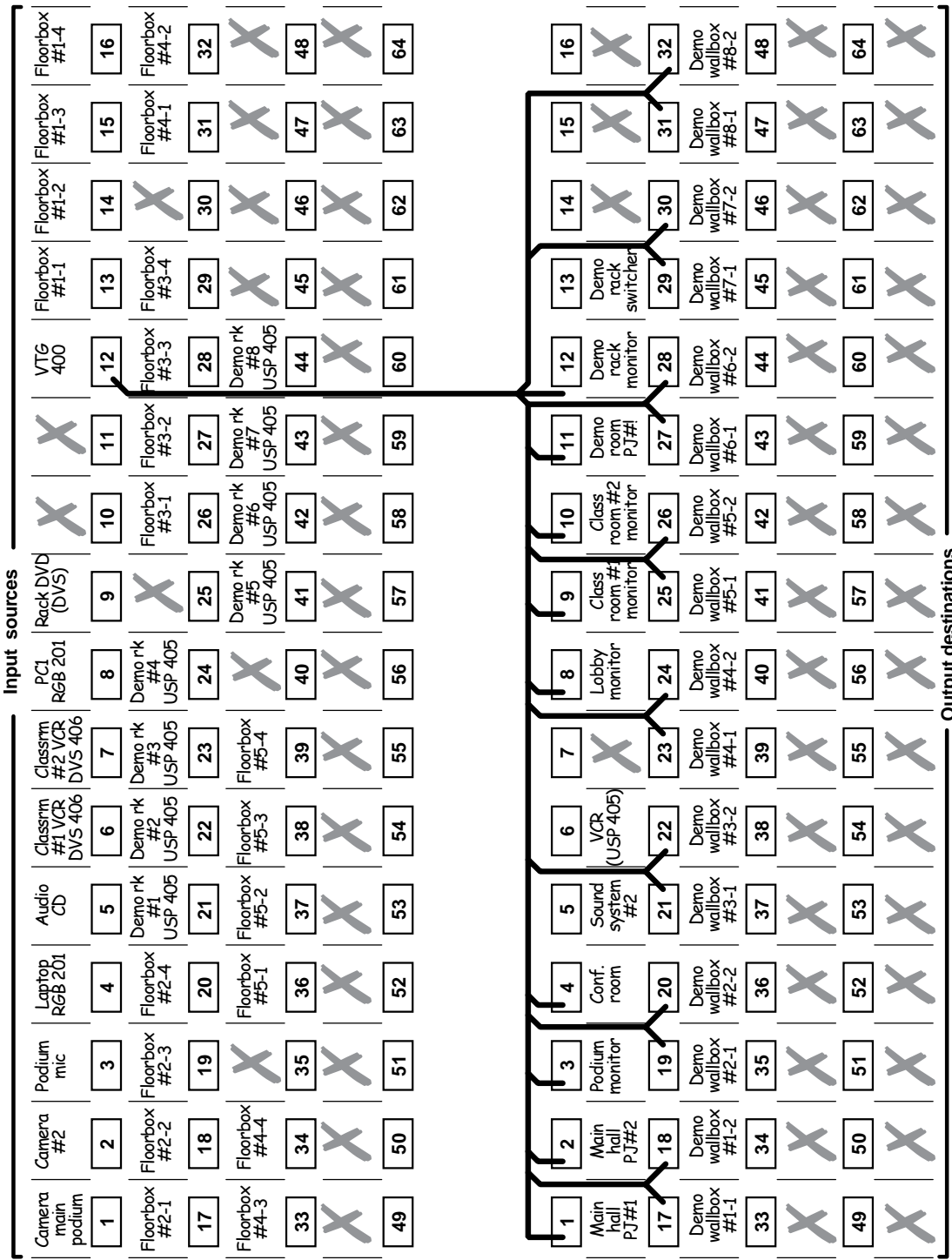

Preset # _____ Title: _____
 Fill in the preset number and use colors, or dashes, etc. to make connecting lines.

Figure 3-7 — Worksheet example 3: Test configuration

Operation, cont'd

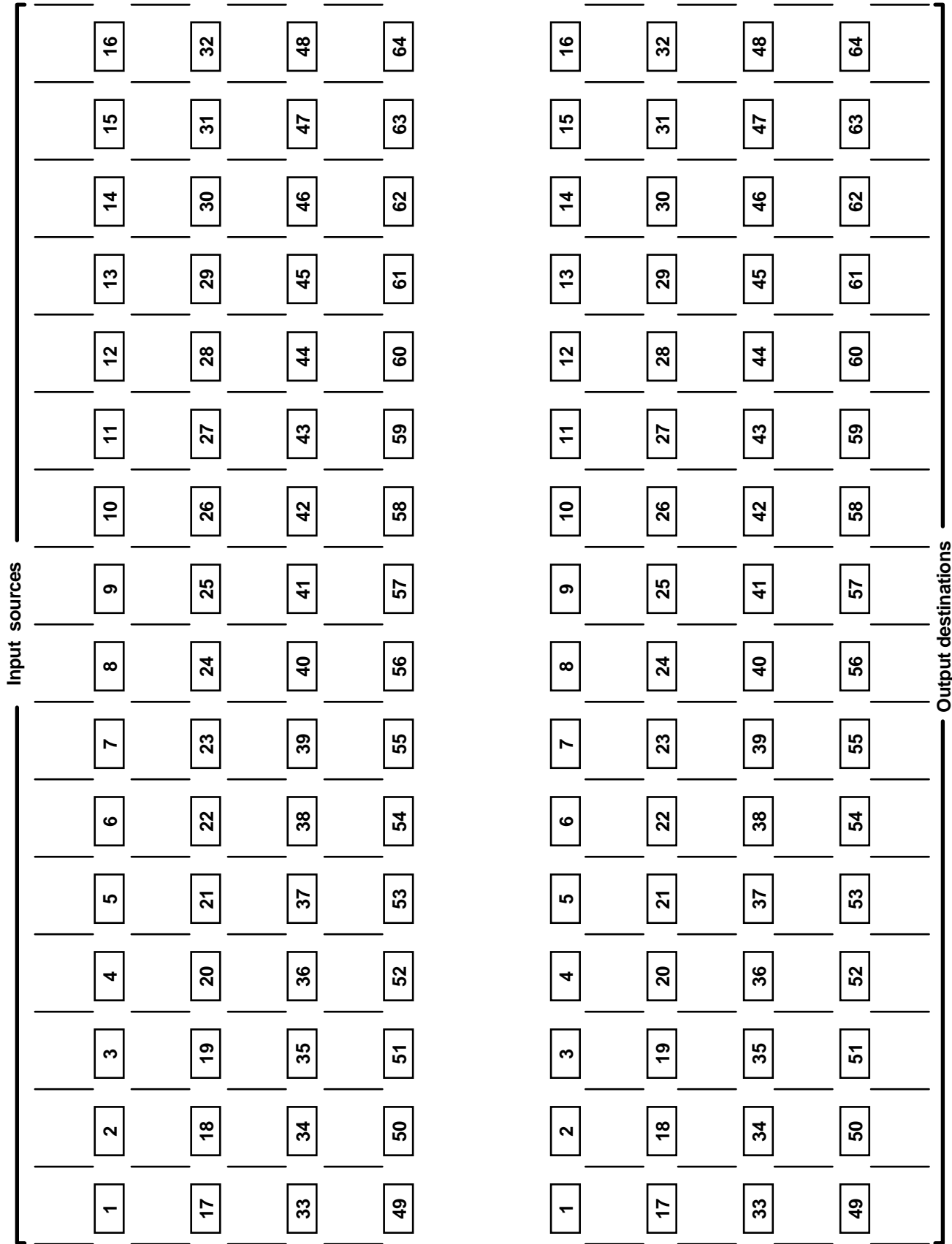

Preset #

Fill in the preset number and use colors, or dashes, etc. to make connecting lines.

Blank configuration worksheet



Fiber Matrix 6400 Switcher

4 Chapter Four

Programmer's Guide

Serial Ports

Ethernet (LAN) Port

Host-to-Switcher Instructions

Switcher-Initiated Messages

Switcher Error Responses

Using the Command/Response Tables

Command/Response Table for IP-Specific SIS Commands

Special Characters

Programmer's Guide

Serial Ports

The switcher has two serial ports that can be connected to a host device such as a computer running the HyperTerminal utility, an RS-232 capable PDA, or a control system. These ports make serial control of the switcher possible. The serial ports are:

- The rear panel Remote (RS-232 or RS-422) port, a 9-pin D female connector
- The front panel Configuration (RS-232) port, a 2.5 mm mini stereo jack

The default protocol for both ports is as follows:

- 9600 baud
- no parity
- 8 data bits
- 1 stop bit
- no flow control

The ports can be configured to operate at the 9600, 19200, 38400, or 115200 baud rate.

NOTE *These two ports are independent of one another. Both the front panel Configuration port connection and the rear panel Remote port connection can be active at the same time.*

NOTE *The switcher can operate at 9600, 19200, 38400, or 115200 baud rates, but Extron recommends leaving these ports at 9600 baud only.*

Rear panel Remote port

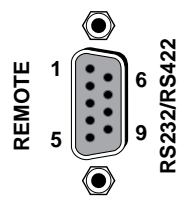

Pin	RS-232	Function	RS-422	Function
1	—	Not used	—	Not used
2	TX	Transmit data	TX-	Transmit data (-)
3	RX	Receive data	RX-	Receive data (-)
4	—	Not used	—	Not used
5	Gnd	Signal ground	Gnd	Signal ground
6	—	Not used	—	Not used
7	—	Not used	RX+	Receive data (+)
8	—	Not used	TX+	Transmit data (+)
9	—	Not used	—	Not used

Remote connector pin assignments

Front panel Configuration port

NOTE This port is hardwired for RS-232 only.

NOTE This port is independent of the rear panel Remote port and is not affected by changes to the rear panel port's protocol. This front panel port's protocol can be changed via an SIS command only. See the Command/Response table for IP-Specific SIS commands, later in this chapter, to configure both ports using an SIS command.

The optional 9-pin D to 2.5 mm mini jack TRS RS-232 cable, part #70-335-01 can be used for connection to the Configuration port.

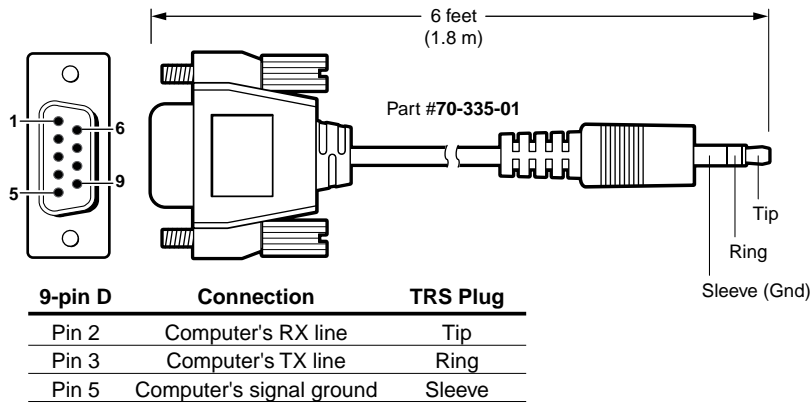

Optional 9-pin TRS RS-232 cable

Ethernet (LAN) Port

The rear panel Ethernet connector on the switcher can be connected to an Ethernet LAN or WAN. Communications between the switcher and the controlling device is via telnet (a TCP socket using port 23). The TCP port can be changed if necessary, via SIS. This connection makes SIS control of the switcher possible using a computer connected to the same LAN or WAN. The SIS commands and the actions of the switcher are identical to the commands and actions the switcher has when communicating with it via RS-232.

Ethernet connection

The Ethernet cable can be terminated as a straight-through cable or a crossover cable and must be properly terminated for your application (figure 4-1).

- **Crossover cable** — Direct connection between the computer and the Fiber Matrix switcher
- **Patch (straight-through) cable** — Connection of the Fiber Matrix switcher to an Ethernet LAN

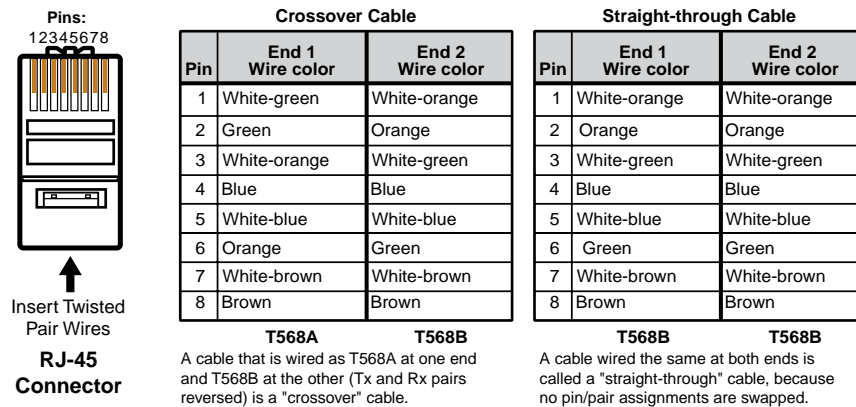

Figure 4-1 — RJ-45 Ethernet connector pin assignments

Default IP addresses

To access the Fiber Matrix switcher via the LAN port, you need the Extron IP address, and may need the subnet mask and the gateway address. If the IP address has been changed to an address comprised of words and characters, you can determine the actual numeric IP address using the ping (ICMP) utility (see appendix A, "Ethernet Connection", for more details). If the addresses have not been changed, the factory-specified defaults are:

- IP address: 192.168.254.254
- Subnet mask: 255.255.0.0
- Gateway address: 0.0.0.0
- DHCP: off

Establishing a connection

Establish a network connection to a Fiber Matrix switcher as follows:

1. Open a TCP socket to port 23 using the switcher's IP address.

NOTE *If the local system administrators have not changed the value, the factory-specified default, 192.168.254.254, is the correct value for this field.*

The switcher responds with a copyright message including the date, the name of the product, firmware version, part number, and the current date/time.

NOTE *If the switcher is not password-protected, the device is ready to accept SIS commands immediately after it sends the copyright message.*

NOTE *If the switcher is password-protected, a password prompt appears below the copyright message.*

2. If the switcher is password protected, enter the appropriate administrator or user password.

If the password is accepted, the switcher responds with *Login User* or *Login Administrator*.

If the password is not accepted, the *Password* prompt reappears.

Connection Timeouts

The Ethernet link times out after a designated period of time of no communications. By default, this timeout value is set to 5 minutes but the value can be changed. See the Configure port timeout SIS commands on page 4-19.

NOTE *Extron recommends leaving the default timeout at 5 minutes and periodically issuing the Query (Q) command to keep the connection active. If there are long idle periods, Extron recommends disconnecting the socket and reopening the connection when another command must be sent.*

Number of connections

A Fiber Matrix switcher can have up to 200 simultaneous TCP connections, including all HTTP sockets and telnet connections. When the connection limit is reached, the switcher accepts no new connections until some have been closed. No error message or indication is given that the connection limit has been reached. To maximize performance of an IP Link device, the number of connections should stay low and unnecessary open sockets should be closed.

Using Verbose Mode

Telnet connections to a Fiber Matrix switcher can be used to monitor for changes that occur on the switcher, such as front panel operations and SIS commands from other telnet sockets or a serial port. For a telnet session to receive change notices from the switcher, the telnet session must be in verbose mode 3. See the Verbose Mode SIS command on page 4-19. In verbose mode 3, the telnet socket reports changes in messages that resemble SIS command responses.

Host-to-Switcher Instructions

The switcher accepts SIS (Simple Instruction Set) commands through either serial port and the LAN port. SIS commands consist of one or more characters per command field. They do not require any special characters to begin or end the command character sequence. Each switcher response to an SIS command ends with a carriage return and a line feed (CR/LF = `↵`), which signals the end of the response character string. A string is one or more characters.

Switcher-Initiated Messages

When a local event such as a front panel operation occurs, the switcher responds by sending a message to the host. The switcher-initiated messages are listed below (underlined).

(c) Copyright 2007, Extron Electronics, Fiber Matrix 6400, Vx.xx, 60-878-01{day, date, time}}

The switcher initiates the copyright message when it is first powered on or when connection via Internet protocol (IP) is established. Vx.xx is the firmware version number.

NOTE *{Day, date, time} are only reported if the connection is via the LAN port.*

]Password:

The switcher initiates the password message immediately after the copyright message when the controlling system is connected using TCP/IP or telnet and the switcher is password protected. This message means that the switcher requires an administrator or user level password before it will perform the commands entered via this link. The switcher repeats the password message response for every entry other than a valid password until a valid password is entered.

↵]Login Administrator↵

↵]Login User↵

The switcher initiates the login message when a correct administrator or user password has been entered. If the user and administrator passwords are the same, the switcher defaults to administrator privileges.

Qik↵

The switcher initiates the Qik message when a front panel switching operation has occurred.

Sprnn↵

The switcher initiates the Spr message when a memory preset has been saved from the front panel. *nn* is the preset number.

Rprnn↵

The switcher initiates the Rpr message when a memory preset has been recalled from the front panel. *nn* is the preset number.

Vmtnn*x↵

The switcher initiates the Vmt message when a channel output mute is toggled on or off from the front panel. *nn* is the output number and *x* is the mute status: 1 = on, 0 = off.

Exen↵

The switcher initiates the Exe message when executive mode is toggled on or off from the front panel. *n* is the executive mode status: 1 = on, 0 = off.

Switcher Error Responses

When the switcher receives an SIS command and determines that it is valid, it performs the command and sends a response to the host device. If the switcher is unable to perform the command because the command is invalid or contains invalid parameters, the switcher returns an error response to the host. The error response codes are:

- E01 — Invalid input channel number (too large)
- E10 — Invalid command
- E11 — Invalid preset number
- E12 — Invalid output number (too large)
- E13 — Invalid value (out of range)
- E14 — Illegal command for this configuration
- E17 — Timeout (caused only by direct write of global presets)
- E21 — Invalid room number
- E24 — Privilege violation (Ethernet, Extron software only)

Using the Command/Response Tables

The command/response tables begin on page 4-9. Lower-case letters are acceptable in the command field except where indicated for the gain and attenuation commands. The table below shows the hexadecimal equivalent of each ASCII character used in the command/response table.

ASCII to HEX Conversion Table										Esc 1B	CR 0D	LF 0A		
Space 20	!	21	"	22	#	23	\$	24	%	25	&	26	'	27
(28)	29	*	2A	+	2B	,	2C	-	2D	.	2E	/	2F
0 30	1	31	2	32	3	33	4	34	5	35	6	36	7	37
8 38	9	39	:	3A	;	3B	<	3C	=	3D	>	3E	?	3F
@ 40	A	41	B	42	C	43	D	44	E	45	F	46	G	47
H 48	I	49	J	4A	K	4B	L	4C	M	4D	N	4E	O	4F
P 50	Q	51	R	52	S	53	T	54	U	55	V	56	W	57
X 58	Y	59	Z	5A	[5B	\	5C]	5D	^	5E	_	5F
` 60	a	61	b	62	c	63	d	64	e	65	f	66	g	67
h 68	i	69	j	6A	k	6B	l	6C	m	6D	n	6E	o	6F
p 70	q	71	r	72	s	73	t	74	u	75	v	76	w	77
x 78	y	79	z	7A	{	7B		7C	}	7D	~	7E	DEL	7F

Symbols are used throughout the table to represent variables in the command/response fields. Command and response examples are shown throughout the table.

Programmer's Guide, cont'd

Symbol definitions

↵	= CR/LF (carriage return/line feed) (hex 0D 0A)	
←	= Carriage return (no line feed, hex 0D)	
•	= Space character	
Esc	= Escape key (hex 1B)	
X1	= Input number	01 – 64
X2	= Input number (for tie)	00 – 64 (00 = untied)
X3	= Output number	01 – 64
X4	= Mute	0 = not muted, 1 = muted
X5	= Output re-clocking rate	00 = auto (default) 01 = bypass
X6	= Group # (for I/O grouping)	1 through 4 groups (0 = no group)
X7	= Global preset #	00 – 64 maximum (00 = current configuration)
X8	= Room # (for room presets)	10 max. (each can have up to 10 presets (X9) assigned)
NOTE	<i>A Room is a subset of operator-selected outputs that relate to each other. The Fiber Matrix switcher supports up to 10 rooms, each of which can consist of from 1 to 16 outputs.</i>	
X9	= Room preset #	10 maximum (0 = current configuration for room)
NOTE	<i>A Room preset is a stored configuration with all of the outputs assigned to a single room. When a room preset is retrieved from memory, it becomes the current configuration.</i>	
X10	= Name	12 characters maximum for input names, output names, global preset names, and room preset names 11 characters maximum for room names Upper- and lower-case alphanumeric characters and _ / and spaces are valid.
NOTE	<i>The following characters are invalid in the name: {space} ~, @ = ' [] { } < > ' " ; : \ and ?.</i>	
X11	= Connection status	0 = no input connected 1 = input connected
X12	= Output rate:	<i>nnnn</i> = actual rate (in MHz) 0000 = no connection or rate mismatch ---- = bypass mode
X13	= Lock mode, power supply	0 = unlocked/not OK 1 = locked/OK
X14	= Number (quantity) of inputs	8, 16, 24, 32, 40, 48, 56, or 64
X15	= Number (quantity) of outputs	8, 16, 24, 32, 40, 48, 56, or 64
X16	= Board installed	0 = No board installed 1 = 8x8 multimode board 2 = 8x8 singlemode board 3 = SDI/HD-SDI board x = Unknown board or mix of transceivers installed
X17	= I/O board slot number	1 – 8
X18	= Fiber optic transceiver module installed	0 = No module installed 1 = Multimode module 2 = Singlemode module 3 = SDI-HD-SDI board (all I/Os on board)
X19	= Firmware version number to second decimal place (<i>x.xx</i>)	
X20	= Verbose firmware version-description-upload date/time.	See the Query firmware version (verbose) command on page 4-16.
X21	= Voltage	Positive or negative voltage and magnitude
X22	= Temperature	Degrees Fahrenheit
X23	= Fan speed (in RPM)	

Command/response table for SIS commands

Command	ASCII command (host to switcher)	Response (switcher to host)	Additional description
Create ties			
NOTE • Commands can be entered back-to-back in a string, with no spaces. For example: 1*1!02*02&003*003%4*8\$. • The quick multiple tie and tie input to all output commands activate all I/O switches simultaneously. • The matrix switchers support 1-, 2-, and 3-digit numeric entries (1*1, 02*02, or 001*001). • The ! tie command, & tie command, and % tie command can be used interchangeably. • The ! tie all command, & tie all command, and % tie all command can be used interchangeably.			
Tie input X2 to output X3 Example:	X2 * X3 ! 1*3!	Out X3 •In X2 •All← Out03•In01•All←	Tie input X2 to output X3 . Tie input 1 to output 3.
Tie input X2 to output X3 Example (see Note, above):	X2 * X3 & 10*4&	Out X3 •In X2 •RGB← Out04•In10•RGB←	Tie input 10 to output 4.
Tie input X2 to output X3 Example (see Note, above):	X2 * X3 % 7*5%	Out X3 •In X2 •Vid← Out05•In07•Vid←	Tie input 7 to output 5.
Quick multiple tie Example:	Esc +Q X2 * X3 !... X2 * X3 ! ← Esc +Q3*4!3*5%3*6! ←	Qik← Qik←	Tie input 3 to output 4, tie input 3 to output 5, and tie input 3 to output 6.
Tie input to all outputs Example:	X2 *! 5*!	In X2 •All← In05•All←	Tie input 5 to all outputs.
Tie input to all outputs Example (see Note, above):	X2 *& 8*&	In X2 •RGB← In08•RGB←	Tie input 8 to all outputs.
Tie input to all outputs Example (see Note, above):	X2 *% 10*%	In X2 •Vid← In10•Vid←	Tie input 10 to all outputs.
Read ties			
NOTE The ! read tie command and & read tie command for RGB and the % read tie command for video can be used interchangeably.			
Read RGB output tie	X3 ! X3 !	X2 ← X2 ←	Input X2 is tied to output X3 .
Read RGB output tie	X3 & X3 &	X2 ← X2 ←	Input X2 is tied to output X3 .
Read video output tie	X3 % X3 %	X2 ← X2 ←	Input X2 is tied to output X3 .
Channel mute commands			
Channel mute	X3 *1B	Vmt X3 *1←	Mute output X3 (no signal is output, but the light output remains active).
Channel unmute	X3 *0B	Vmt X3 *0←	Unmute output X3 (signal is output).
Read channel mute	X3 B	X4 ←	1 = mute on, 0 = mute off.
Global channel mute	1*B	Vmt1←	Mute all output channels.
Global channel unmute	0*B	Vmt0←	Unmute all output channels.

NOTE **X2** = Input number
X3 = Output number
X4 = Mute

00 – 64 (00 = untied)
01 – 64
0 = off (unmuted)
1 = on (muted)

Command/response table for SIS commands (continued)

Command	ASCII command (host to switcher)	Response (switcher to host)	Additional description
Save, recall, and directly write presets			
NOTE <ul style="list-style-type: none"> If you try to recall a preset that is not saved, the matrix switcher responds with the error code E11. If a room is not defined (does not exist in the switcher), the matrix switcher responds with the error code E21. The following characters are invalid in preset names: +, -, ` @ = [] { } ' " ; : \ and ?. 			
Save current configuration as a global preset	<code>[X7],</code>	Spr[X7]←	Command character is a comma.
Example:	9,	Spr09←	Save current ties as preset 9.
Recall a global preset	<code>[X7].</code>	Rpr[X7]←	Command character is a period.
Example:	5.	Rpr05←	Recall preset 5, which becomes the current configuration.
Save current ties as a room preset	<code>[X8]*[X9],</code>	Rmm[X8]•Spr[X9]←	Command character is a comma.
Example:	3*9,	Rmm03•Spr09←	Save current ties as preset 9 for room 3.
Direct write process —			
NOTE The direct write of a global preset should always be preceded by a clear global preset ties command of that same preset number, as shown below. In a directly-written preset, each output position's tied input (or no tied input) remains unchanged unless overwritten or cleared.			
If you do not clear the ties in a global preset number before you directly write a global preset to that number, ties that are part of the previous version of the specified preset with the same number can unexpectedly become part of the newly-created preset.			
Clear a global preset's ties	<code>[Esc]+[X7]P0*!←</code>	Spr[X7]←	Clear all ties in preset [X7].
Directly write a global preset	<code>[Esc]+[X7]P[X2]*[X3]! [X2]*[X3]% [X2]*[X3]\$... [X2]*[X3]%←</code>	Spr[X7]←	Enter as many ties as are valid for this configuration. The ! tie command, & tie, and % tie commands are all valid.
Example:	<code>[Esc]+27P0*!←</code> <code>[Esc]+27P12*5!10*09%3*2!3*8&←</code>	Spr27←	Clear all ties in preset 27. <u>Brackets are shown to separate ties for clarity only.</u> Create global preset 27, which ties input 12 to output 5, input 10 to output 9, input 3 to output 2, and input 3 to output 8.
Write room outputs	<code>[Esc][X8],[X3]¹, [X3]², ... [X3]ⁿMR←</code>	Mpr[X8],[X3] ¹ , [X3] ² , ... [X3] ⁿ ←	See notes.
NOTE <ul style="list-style-type: none"> A room can contain a maximum of 16 outputs. An output can belong to only one room. The maximum number of rooms ([X8]) is 10. If no room name is assigned, the default name is "Room #[X8]•[X3]¹,•[X3]²,•[X3]ⁿ". 			
Example:	<code>[Esc]8,3,04,5,6MR←</code>	Mpr08,03,04,05,06←	Outputs 3, 4, 5, and 6 are assigned to room 8.

NOTE [X2] = Input number	00 – 64 (00 = untied)
[X3] = Output number	01 – 64
[X7] = Global preset #	00 – 32 (00 = current configuration)
[X8] = Room # (for room presets)	10 max. (Each can have up to 10 presets ([X9]) assigned.)
[X9] = Room preset #	00 – 10 (00 = current configuration for room)

Programmer's Guide, cont'd

Command/response table for SIS commands (continued)

Command	ASCII command (host to switcher)	Response (switcher to host)	Additional description
Save, recall, and directly write presets (continued)			
Read room outputs <i>Example:</i>	<code>[Esc][X8]MR ←</code> <code>[Esc]3MR ←</code>	<code>[X10][X3]¹, [X3]², ... [X3]ⁿ ←</code> Class 1,01,02,08,09 ←	Outputs 1, 2, 8, and 9 are assigned to room 3, which named "Class 1".
Recall room preset	<code>[X8][X9].</code>	Rmm[X8]•Rpr[X9] ←	Command character is a period.
Directly write a room preset <i>Example:</i>	<code>[Esc]+[X8]*[X9]P[X2]*[X3].[X2]*[X3]%[X2]*[X3]\$... [X2]*[X3] ←</code> <code>[Esc]+7*3P12*7&11*5&4*5%6*6! ←</code>	Rmm[X8]•Spr[X9] ← Rmm07•Spr03 ←	Enter as many ties as are valid for this configuration. The ! tie command, & tie, and % tie commands are all valid and equivalent. <u>Brackets are shown to separate ties for clarity only.</u> Create preset 3 for room 7, which ties input 12 to output 7, input 11 to output 5, input 4 to output 5, and input 6 to output 6.
View ties, mutes, and presets			
View output tie <i>Example:</i>	<code>[X3]&</code> 15&	<code>[X2] ←</code> 27 ←	Input 27 is tied to output 15.
View output tie <i>Example:</i>	<code>[X3]%</code> 7%	<code>[X2] ←</code> 02 ←	Input 2 is tied to output 7.
View output mutes	<code>[Esc]VM ←</code>	<code>[X4]¹, [X4]², ... [X4]ⁿ ←</code>	Each [X4] response is the mute status of an output, starting from output 1. n is the highest-numbered output.

NOTE	[X2] = Input number	00 – 64 (00 = untied)
	[X3] = Output number	01 – 64
	[X4] = Mute	0 = not muted, 1 = muted
	[X8] = Room # (for room presets)	10 max. (Each can have up to 10 presets ([X9]) assigned.)
	[X9] = Room preset #	00 – 10 (00 = current configuration for room)
	[X10] = Name	12 characters maximum for input and output names

Command/response table for SIS commands (continued)

Command	ASCII command (host to switcher)	Response (switcher to host)	Additional description
View ties, mutes, and presets (continued)			
View global preset configuration	<code>[Esc][X7][X3]*1VC←</code>	<code>[X2]ⁿ•[X2]ⁿ⁺¹•...•[X2]ⁿ⁺¹⁵•Vid←</code>	Show preset <code>[X7]</code> 's configuration. Show the input tied to 16 sequential outputs, starting from output <code>[X3]</code> . <i>n</i> is the highest-numbered input.
<i>Command description:</i>	preset # <code>([X7])</code> *starting output # <code>([X3])</code> *1VC		
<i>Response description:</i>	input # <code>([X2])</code> tied to <code>[X3]•[X2]</code> tied to <code>[X3]+1•[X2]</code> tied to <code>[X3]+2• ... •[X2]</code> tied to <code>[X3]+15•Vid←</code>		
<i>Example (8 x 8 matrix):</i>	<code>[Esc]23*1*1VC←</code>		
		<pre> input 8 tied to output 4 input 2 tied to output 3 no tied input outputs do not exist Response = tied input: 08•08•02•08•08•01•00•00•...•Vid← Output: 1 2 3 4 5 6 7 8 09 10 11 12 13 14 15 16 </pre>	
		Each position shown in the response is an output: left = output 1, right = output 16. (Outputs 9 through 16 are not present on this Fiber Matrix.) The number in each position is the input tied to that output.	
		In this example, video input 8 is tied to outputs 1, 2, 4, and 5; input 2 is tied to output 3; and input 1 is tied to output 6. No inputs are tied to outputs 7 and 8.	
NOTE	<code>[Esc][X7]*1*1VC←</code> where <code>[X7] = 0</code> returns the switcher's current video configuration.		
View room preset configuration	<code>[Esc][X8][X9][X3]*1VC←</code>	<code>[X2]ⁿ•[X2]ⁿ⁺¹•...•[X2]ⁿ⁺¹⁵•Vid←</code>	Show room <code>[X8]</code> , preset <code>[X9]</code> 's configuration. Show the input tied to up to 16 outputs assigned to room <code>[X8]</code> . <i>n</i> is the highest-numbered input.
<i>Command description:</i>	room # <code>([X8])</code> *room preset # <code>([X9])</code> *starting output # <code>([X3])</code> *1VC		
<i>Response description:</i>	input # <code>([X2])</code> tied to <code>[X3]•[X2]</code> tied to <code>[X3]+1•[X2]</code> tied to <code>[X3]+2• ... •[X2]</code> tied to <code>[X3]+15•Vid←</code>		
List input link detection and SDI/HD-SDI output rate			
View all input connections	OLS	<code>[X11]¹[X11]²[X11]³...[X11]⁶⁴←</code>	Each <code>[X11]</code> response is the connection status of an input, starting from input 1.
<i>Example:</i>	OLS	<pre> no input detected input detected Response Status: 0 0 0 1 1 1 0 ... 0← Input: 1 2 3 4 5 6 7 64 </pre>	
List individual SDI/HD-SDI output rate	<code>[X3]LS</code>	<code>[X12]←</code>	Show output rate <code>[X12]</code> in Mbps for output <code>[X3]</code> . (If there is no connection for the specified output, 0000 is displayed.)

NOTE	<code>[X2]</code> = Input number	00 – 64 (00 = untied)
	<code>[X3]</code> = Output number	01 – 64
	<code>[X7]</code> = Global preset #	00 – 32 (00 = current configuration)
	<code>[X8]</code> = Room # (for room presets)	10 max. (Each can have up to 10 presets <code>([X9]</code> s) assigned.)
	<code>[X9]</code> = Room preset #	00 – 10 (00 = current configuration for room)
	<code>[X11]</code> = Connection status	0 = no input connected
		1 = input connected
	<code>[X12]</code> = Output rate:	<i>nnnn</i> = actual rate (in megabits per second)
		0000 = no connection or rate mismatch
		---- = bypass mode

Programmer's Guide, cont'd

Command/response table for SIS commands (continued)

Command	ASCII command (host to switcher)	Response (switcher to host)	Additional description
Names			
Write global preset name <i>Example:</i>	Esc X7 , X10 NG← Esc 1,Security 1NG←	Nmg X7 , X10 ← Nmg01,Security 1←	Name global preset 1 "Security 1".
Read global preset name <i>Example:</i>	Esc X7 NG← Esc 2NG←	X10 ← Security 2←	Global preset 2 is named "Security 2".
Write room name <i>Example:</i>	Esc X8 , X10 NR← Esc 1,Classrm 1NR←	Nmr X8 , X10 ← Nmr01,Classrm 1←	Name room 1 "Classrm 1".
Read room name	Esc X8 NR←	X10 ←	
Write room preset name <i>Example:</i>	Esc X8 * X9 , X10 NP← Esc 1*3,Podium_DVDNP←	Nmp X8 * X9 , X10 ← Nmp01*3,Podium_DVD←	Name room1, preset 3 "Podium_DVD".
Read room preset name	Esc X8 , X9 NP←	X10 ←	
NOTE	<ul style="list-style-type: none"> • Do not use leading spaces in preset names. • If a preset is unassigned, the X10 displays [unassigned]. • If a global preset is saved, but not yet named, the default name is Preset X7. • If a room preset is saved, but not yet named, the default name is RmX8 PrstX9. 		
Write input name <i>Example:</i>	Esc X1 , X10 NI← Esc 1,Podium camNI←	Nmi X1 , X10 ← Nmi01,Podium cam←	Name input 1 "Podium cam".
Read input name	Esc X1 NI←	X10 ←	
Write output name <i>Example:</i>	Esc X3 , X10 NO← Esc 1,Main PJ1NO←	Nmo X3 , X10 ← Nmo01,Main PJ1←	Name output 1 "Main PJ1".
Read output name	Esc X3 NO←	X10 ←	
Front panel lockout (Executive mode)			
Lock front panel	1X	Exe1←	Enable executive mode.
Unlock front panel	0X	Exe0←	Disable executive mode.
View lock status	X	X13 ←	

NOTE	X1 = Input number	01 – 64
	X3 = Output number	01 – 64
	X7 = Global preset #	00 – 32 (00 = current configuration)
	X8 = Room # (for room presets)	10 max. (Each can have up to 10 presets (X9) assigned.)
	X9 = Room preset #	00 - 10 (00 = current configuration for room)
	X10 = Name	12 characters maximum for global and room preset names 11 characters maximum for room names
	X13 = Lock mode	0 = unlocked 1 = locked

Command/response table for SIS commands (continued)

Command	ASCII command (host to switcher)	Response (switcher to host)	Additional description
Resets			
Reset global presets and names	<code>Esc</code> ZG←	Zpg↵	Clear all global presets and their names.
Reset one global preset	<code>Esc</code> X7ZG←	ZpgX7↵	Clear global preset X7.
Reset all mutes	<code>Esc</code> ZZ←	Zpz↵	Unmute all outputs.
Reset room map	<code>Esc</code> ZR←	Zpr↵	Clear all room definitions.
Reset individual room	<code>Esc</code> X8ZR←	ZprX8↵	Delete room X8.
Reset individual room preset	<code>Esc</code> X8X9ZP←	ZppX8X9↵	Clear an individual room preset and name.
Reset whole switcher	<code>Esc</code> ZXXX←	Zpx↵	Clear all ties and presets.
Absolute reset	<code>Esc</code> ZQQQ←	Zpq↵	Similar to Reset whole switcher , plus clear the IP address to 192.168.254.254 and subnet mask to 255.255.000.000.
Erase user-supplied Web pages/files	<code>Esc</code> filenameEF←	Delfilename↵	
Information requests			
Information request	I	V[X14]X[X15]•A[X14]X[X15]•S[X16]X[X16]²..X[X16]ᵇ↵	V[X14]X[X15] shows the number of available inputs and outputs for this configuration. A[X14]X[X15] has no meaning for this product. S[X16]X[X16]²..X[X16]ᵇ shows the board type installed in each slot.
Slot/plane/LC information	0*X[X17]I	X[X18]ᵇX[X18]ᵇX[X18]ᵇX[X18]ᵇX[X18]ᵇX[X18]ᵇX[X18]ᵇX[X18]ᵇ↵	
Request part number	N	60-878-01↵	See appendix A for part numbers.
NOTE There are up to three separate sets of Extron firmware on which the switcher can report: the controller firmware, which is the overall control firmware; the Ethernet protocol firmware, which handles the Ethernet interface; and the latest optional Extron firmware update, which is available at www.extron.com .			
Query firmware version	Q	X[X19]↵	
Example:	Q	1.23↵	The factory-installed controller firmware version is 1.23 (sample value only).

- NOTE**
- X7 = Global preset #
 - X8 = Room # (for room presets)
 - X9 = Room preset #
 - X14 = Number (quantity) of inputs
 - X15 = Number (quantity) of outputs
 - X16 = Board installed
 - X17 = I/O board slot number
 - X18 = Fiber optic transceiver module installed
 - X19 = Firmware version number to second decimal place (x.xx)
- 00 – 32 (00 = current configuration)
 - 10 max. (Each can have up to 10 presets (X9s) assigned.)
 - 00 – 10 (00 = current configuration for room)
 - 8, 16, 24, 32, 40, 48, 56, or 64
 - 8, 16, 24, 32, 40, 48, 56, or 64
 - 0 = No board installed, 1 = 8x8 multimode board, 2 = 8x8 singlemode board, 3 = SDI/HD-SDI board, x = unknown board or mix of transceivers installed
 - 1 – 8
 - 0 = no module installed, 1 = multimode, 2 = singlemode

Programmer's Guide, cont'd

Command/response table for SIS commands (continued)

Command	ASCII command (host to switcher)	Response (switcher to host)	Additional description									
Information requests (continued)												
Query controller firmware version (verbose)	0Q	X19 • X20 • X20 ←	Provide a detailed status of the Ethernet protocol firmware, the controller firmware, and any firmware upgrade. The firmware that is running is marked by an asterisk (*). A caret (^) indicates that the firmware has a bad checksum or an invalid load. ??? indicates that firmware is not loaded.									
<i>Response description:</i>	<i>Ethernet protocol firmware version-controller firmware version-updated firmware version</i> ←											
<i>Example:</i>	0q											
	<table border="0"> <tr> <td style="text-align: center;">Description</td> <td style="text-align: center;">* indicates the version running</td> <td style="text-align: center;">Upload date and time</td> </tr> <tr> <td style="text-align: center;">1.23-1.00(1.68-FOMX Series</td> <td style="text-align: center;">-Wed, 20 Feb 2008 00:00:00 GMT)-1.00*(1.06-FOMX Series</td> <td style="text-align: center;">-Mon, 17 Mar 2007 16:39:21 GMT)</td> </tr> <tr> <td style="text-align: center;">Ethernet protocol firmware</td> <td style="text-align: center;">Fiber Matrix firmware version</td> <td style="text-align: center;">Updated firmware version</td> </tr> </table>	Description	* indicates the version running	Upload date and time	1.23-1.00(1.68-FOMX Series	-Wed, 20 Feb 2008 00:00:00 GMT)-1.00*(1.06-FOMX Series	-Mon, 17 Mar 2007 16:39:21 GMT)	Ethernet protocol firmware	Fiber Matrix firmware version	Updated firmware version		
Description	* indicates the version running	Upload date and time										
1.23-1.00(1.68-FOMX Series	-Wed, 20 Feb 2008 00:00:00 GMT)-1.00*(1.06-FOMX Series	-Mon, 17 Mar 2007 16:39:21 GMT)										
Ethernet protocol firmware	Fiber Matrix firmware version	Updated firmware version										
Request system status	S	X21 • X21 • X21 • X21 • X21 • X21 • X21 • X21 • X22 • X23 • X23 ←										
<i>Response description:</i>		+3.3V•+5V•+2.5V•+1.2V•+12V (backplane)•+12V (redundant supply)•+12V (primary supply)•Temp•Fan1 RPM•Fan2 RPM←										
<i>Example:</i>	S	Backplane receiving 12.00 V Internal temperature 80.6° F 3.27•4.95•2.48•1.22•12.00•12.06•12.12•+080.60•03013•02860← 3.3 V power system at 3.27 V Fan 1 rotating at 3,013 RPM										
NOTE The response to the View File Directory command differs, depending on whether the command is sent via an RS-232/RS-422 or Telnet connection or sent via a Web browser connection.												
View file directory RS-232/RS-422 port and Telnet	Esc DF←	filename1,date/time,length← filename2,date/time,length← filename3,date/time,length← • • filenamen,date/time,length← # of Bytes•Left←←←	List user-supplied files.									
View file directory Web browser	Esc DF←	Var file = new array (); File [1] = 'filename1,date1,filesize1'; File [2] = 'filename2,date2,filesize2'; File [3] = 'filename3,date3,filesize3'; • • File [n] = 'filenamen,daten,filesize'; File [n+1] = # of Bytes•Left	List user-supplied files.									
Erase user-supplied Web pages/files	Esc filenameEF←	Delfilename←										

- NOTE**
- X19** = Firmware version number to second decimal place (x.xx)
 - X20** = Verbose firmware version-description-upload date/time.
 - X21** = Voltage Positive or negative voltage and magnitude
 - X22** = Temperature Degrees Fahrenheit
 - X23** = Fan speed (in RPM)

Command/Response Table for IP-Specific SIS Commands

Symbol definitions

X30 = Matrix name	(Up to 240 alphanumeric characters)
NOTE The following characters are invalid in the name: {space} ~ , @ = ` [] { } < > ' " ; : \ and ?.	
X31 = Default name	Fiber-Matrix-64+ + last 3 pairs of MAC address
X32 = Time and date (for set)	In the format: MM/DD/YY•HH:MM:SS where: MM = month: 01 (January) through 12 (December) DD = day: 01 through 31 YY = year: 00 through 99 HH = hour: 00 through 23 MM = minutes: 00 through 59 SS = seconds: 00 through 59
X33 = Time and date (for read)	In the format: Day,•DD•Mmm•YYYY•HH:MM:SS where: Day = weekday: Mon through Sun DD = date: 01 through 31 Mmm = month: Jan through Dec YYYY = year: 2000 through 2099 HH = hour: 00 through 24 MM = minutes: 00 through 59 SS = seconds: 00 through 59
X34 = GMT offset	-12.0 through +14.0. Hours and minutes removed from GMT
X35 = Daylight Saving Time	0 = Daylight Saving Time off/ignore 1 = Daylight Saving Time on (northern hemisphere) 2 = Daylight Saving Time on (Europe) 3 = Daylight Saving Time on (Brazil)
X36 = IP address	###.###.###.###
X37 = Hardware (MAC) address	##-##-##-##-##-##
X38 = Number of open connections	0 – 255
X39 = Password	12 alphanumeric characters
NOTE The following characters are invalid in passwords: {space} + ~ , @ = ` [] { } < > ' " ; : \ and ?.	
X40 = Domain name	Standard domain name rules apply (for example: xxx.com)
NOTE The following characters are invalid in a domain name: {space} + ~ , = ` [] { } < > ' " ; : \ and ?. The @ character is acceptable only as the lead-in to the domain name (such as @extron.com).	
X41 = E-mail account	65 - 72. 65 = e-mail recipient 1, 66 = 2, 67 = 3, ... 72 = recipient 8
X42 = E-mail address	Typical e-mail address format (for example: nmm@xxx.com)
X43 = Notification selections, part 1	I = inputs F = fans P = power supply
X44 = Notification selections, part 2	If X43 = I, then X44 = 00 (all inputs), or 01 through 64 (input 1 through input 64) If X43 = F, then X44 = 00 (both fans), 01 (fan 1), or 02 (fan 2) If X43 = P, then X44 = 00 (both power supplies [PSs]), 01 (primary PS), or 02 (redundant PS)
X45 = Notify when?	0 = no response 1 = fail/missing 2 = fixed/restored 3 = both 1 & 2 4 = suspend
X46 = DHCP	0 = off, 1 = on
X47 = Port #	00 (all ports), 01 (rear panel), 02 (front panel), 03 – 99
X48 = Baud rate	9600, 19200, 38400, 115200
X49 = Parity	odd, even, none, mark, space (Only the first letter required.)
X50 = Data bits	7, 8
X51 = Stop bits	1, 2
X52 = Port type	0 = RS-232 1 = RS-422
X53 = Verbose mode	0 = clear/none (default for Telnet connection) 1 = verbose mode (default for RS-232/RS-422 connection) 2 = tagged responses for queries 3 = verbose mode and tagged for queries
NOTE If tagged responses is enabled, all read commands return the constant string and the value as the set command does (for example, the read matrix name command [Esc]CN← , returns lpn•X30←).	
X54 = Port timeout interval (in 10-sec. increments)	1 (= 10 seconds) – 65000 (default is 30 = 300 seconds = 5 minutes)

Programmer's Guide, cont'd

Command/response table for IP-Specific SIS commands

Command	ASCII command (host to switcher)	Response (switcher to host)	Additional description
IP setup commands			
Set matrix name	Esc X30CN ←	Ipn•X30 ←	
Read matrix name	Esc CN ←	X30 ←	
Reset matrix name to factory default	Esc •CN ←	Ipn•X30 ←	"Fiber-Matrix-64-" plus the last 3 pairs of the MAC address.
Set time and date	Esc X32CT ←	IptX32 ←	
Read time and date	Esc CT ←	X33 ←	
Set GMT offset	Esc X34CZ ←	IpzX34 ←	In the command, the divider between hours and minutes can be either a colon or a period. In the response, the divider is a colon.
<i>Example:</i>	Esc 8.0CZ ←	Ipz+08:00 ←	
Set Daylight Saving Time	Esc X35CX ←	X35 ←	
Read Daylight Saving Time	Esc CX ←	X35 ←	
Set IP address	Esc X36CI ←	IpiX36 ←	
Read IP address	Esc CI ←	X36 ←	
Read hardware address	Esc CH ←	X37 ←	
Read # of open connections	Esc CC ←	X38 ←	
Set subnet mask	Esc X36CS ←	IpsX36 ←	
Read subnet mask	Esc CS ←	X36 ←	
Set gateway IP address	Esc X36CG ←	IpgX36 ←	
Read gateway IP address	Esc CG ←	X36 ←	
Set administrator password	Esc X39CA ←	Ipa•X39 ←	
Read administrator password	Esc CA ←	X39 ←	
Reset (clear) administrator password	Esc •CA ←	Ipa• ←	
Set user password	Esc X39CU ←	Ipu•X39 ←	
Read user password	Esc CU ←	X39 ←	
Reset (clear) user password	Esc •CU ←	Ipu• ←	
Set mail server, domain name	Esc X36,X40,X39CM ←	IpmX36,X40,X39 ←	
Read mail server, domain name	Esc CM ←	X36,X40,X39 ←	
Set e-mail recipient	Esc X41,X42CR ←	IprX41,X42, ←	This command sets the recipient. To receive e-mail notifications, you must then set the events that the switcher reports, using one or more separate Set e-mail events (EM) commands (see next page).
<i>Example:</i>	Esc 72,Jsmith@folklore.netCR ←	Ipr72,Jsmith@folklore.net, ←	
Read e-mail recipient	Esc X41CR ←	X42, ←	

Command/response table for IP-Specific SIS commands (continued)

Command	ASCII command (host to switcher)	Response (switcher to host)	Additional description
IP setup commands (continued)			
Set e-mail events for recipient	<code>Esc[X43][X41],[X44],[X45]EM←</code>	<code>Ipe[X43],[X41],[X44],[X45]←</code>	You must first have set an e-mail recipient for the e-mail account number (<code>[X41]</code>), using the separate Set e-mail recipient (CR) command. E-mail account #72 (recipient #8), JSmith, will receive fail/missing and fixed/restored messages for all inputs.
<i>Example:</i>	<code>EscI [X43]72 [X41],0 [X44],3 [X45]EM←</code>	<code>IpeI*72*0*3←</code>	
Read e-mail events for recipients	<code>Esc[X43][X41],[X44]EM←</code>	<code>[X45][X45][X45],...,[X45]←</code>	
Set DHCP on or off	<code>Esc[X46]DH←</code>	<code>Idh[X46]←</code>	<code>[X46]</code> : 0 = off, 1 = on
Read DHCP on/off status	<code>EscDH←</code>	<code>[X46]←</code>	
Set serial port parameters	<code>Esc[X47]*[X48],[X49],[X50],[X51]CP←</code>	<code>Cpn[X47]•Ccp[X48],[X49],[X50],[X51]←</code>	
Read serial port parameters	<code>Esc[X47]CP←</code>	<code>[X48],[X49],[X50],[X51]←</code>	
Set serial port mode	<code>Esc[X47]*[X52]CY←</code>	<code>Cpn[X47]•Cty[X52]←</code>	<code>[X52]</code> : 0 = RS-232, 1 = RS-422, 2 = RS-485
Read serial port mode	<code>Esc[X47]CY←</code>	<code>[X52]←</code>	
Set verbose mode	<code>Esc[X53]CV←</code>	<code>Vrb[X53]←</code>	
Read verbose mode	<code>EscCV←</code>	<code>[X53]←</code>	
Configure current port timeout	<code>Esc0*[X54]TC←</code>	<code>Pti0*[X54]←</code>	
View current port timeout	<code>Esc0TC←</code>	<code>[X54]←</code>	
Configure global IP port timeout	<code>Esc1*[X54]TC←</code>	<code>Pti1*[X54]←</code>	
View global IP port timeout	<code>Esc1TC←</code>	<code>[X54]←</code>	

Special Characters

The HTML language reserves certain characters for specific functions. The switcher does not accept these characters as part of preset names, the switcher's name, passwords, or locally created file names.

The switcher rejects the following characters:

{space (spaces are ok for names)} + ~ , @ = ' [] { } < > ' " semicolon (;)
colon (:)| \ and ?.

Programmer's Guide, cont'd



Fiber Matrix 6400 Switcher

5 Chapter Five

Matrix Software

Matrix Switchers Control Program

Button Label Generator Program

Matrix Software

Matrix Switchers Control Program

The Windows-based Extron Matrix Switchers Control Program communicates with the switcher via the Ethernet LAN port or either serial port to provide an easy way to set up ties and sets of ties. The program is compatible with Windows 2000 and Windows XP. Updates to these programs can be downloaded from the Extron Web site (www.extron.com).

Installing the software

The program is contained on the Extron Software Products disk. Install the software as follows:

NOTE For full functionality, install both of the following programs:

- The Matrix Switchers Control Program
 - The Firmware Loader
1. Insert the disk into the drive. The installation program should start automatically. If it does not self-start, run Launch.exe from the disk.

The Extron software disk window appears (figure 5-1).

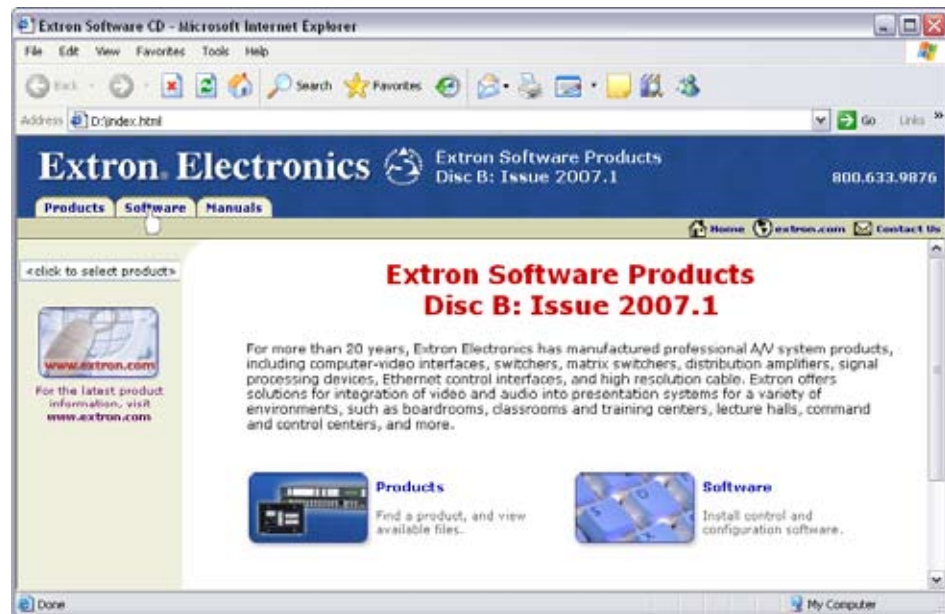

Figure 5-1 — Software disk window

2. Click the Software tab (figure 5-1).
3. Scroll to the desired program and click **Install** (figure 5-2).



Figure 5-2 — Software installation

-
4. Follow the on-screen instructions. By default, the installation of the Matrix Switchers Control Program creates a C:\Program Files\Extron\Matrix_Switchers directory, and it places the following four icons into a group folder named “Extron Electronics\Matrix Switchers”:

- MATRIX Switcher+ Control Program
- MATRIX Switcher+ Help
- Check for Matrix Updates
- Uninstall MATRIX Switcher

NOTE Besides the LAN port, the Fiber Matrix switcher can support remote control via either the rear panel Remote RS-232/RS-422 Remote port or the front panel Configuration port.

Remote RS-232/RS-422 port — The port can be configured for either the RS-232 or RS-422 serial communication protocol and operate at the 9600, 19200, 38400, or 115200 baud rate.

Configuration port — The port supports RS-232 serial communication protocol only. The port can operate at the 9600, 19200, 38400, or 115200 baud rate, but Extron recommends leaving this port at the 9600 baud rate.

See the Serial port parameters commands on page 4-19 to configure either port using an SIS command.

Software operation via Ethernet

When a matrix switcher is connected to an Ethernet WAN or LAN, up to 200 users can operate it, locally or remotely, using the Matrix Switchers Control Program. See “Ethernet connection” in chapter 2, “Installation”, for installation details.

Connection to the switcher via the Ethernet is password protected. There are two levels of password protection: administrator and user. Administrators have full access to all switching capabilities and editing functions. Users can select inputs and outputs, set and recall presets, and view all settings with the exception of passwords. If the same password or no password is required for logging on, all personnel log on with administrator privileges. Fields and functions that exceed user privileges are not selectable in the Matrix Switchers Control Program when the operator is logged on as a user.

The IP Settings/Options window (figure 5-7 on page 5-8) provides a location for viewing and, if connected via the RS-232 link or if logged on via the Ethernet port as an administrator, editing settings unique to the Ethernet interface. See “IP Settings/Options window” later in this chapter for more details.

Matrix Software, cont'd

Using the Matrix Switcher Control software

Many items found in the Matrix Switchers Control Program are also accessible via front panel controls (see chapter 3, "Operation") and under SIS control (see chapter 4, "Programmer's Guide"). The Matrix Switcher Help Program provides information on settings and on how to use the control program, itself.

1. To run the Matrix Switchers Control Program, click **Start > Programs > Extron Electronics > Matrix Switchers > MATRIX Switcher + Control Pgm.**



The Comm Port Selection window (figure 5-3) appears.

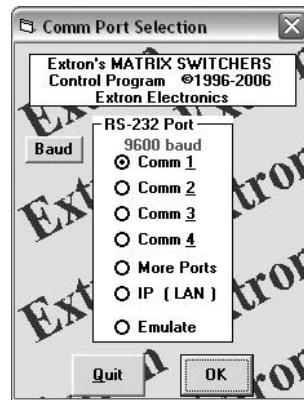
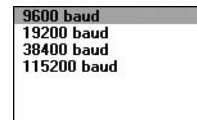

Figure 5-3 — Comm port selection window

2. Choose either the comm port that is connected to one of the switcher's serial ports, IP [LAN], or Emulate.

- o If you selected a comm port, check the baud rate displayed in the comm port selection window. If you need to change the baud rate, click on the **Baud** button and double-click on the desired baud rate.



Available rates are 9600, 19200, 38400, and 115200. The default is 9600.

Click **OK**. The Extron Matrix Switchers Control Program window (figure 5-5 and figure 5-6) appears, displaying the current configuration of the attached matrix. Proceed to step 4.

- o If you selected IP [LAN], click OK and proceed to step 3.
- o If you selected Emulate, click OK and see "Using emulation mode" on page 5-22.

3. If you selected IP [LAN] in step 2, the IP Connection window appears (figure 5-4).

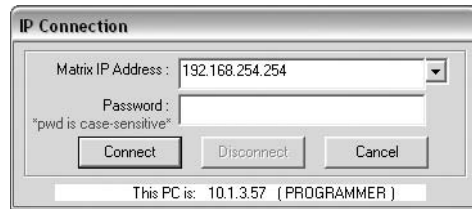

Figure 5-4 — Address and password entry

- a. Examine the Matrix IP Address field in the IP Connection window. The field displays the last Extron IP address entered.

If the IP address is correct, proceed to step 3b.

If the address is not correct, either click in the Extron IP Address field and enter the IP address or click on the scroll down button (▼) and select from among the recently used addresses. Proceed to step 3b.

NOTE *If the local system administrators have not changed the value, the factory-specified default, 192.168.254.254, is the correct value for this field.*

- b. If the switcher is password protected, click in the Password field and enter the appropriate administrator or user password.
- c. Click **Connect**.

If you logged on using the administrator password, the program connects you to the matrix switcher with all of the administrator rights and privileges. The Extron Matrix Switchers Control Program window (figure 5-5 and figure 5-6) appears, displaying the current configuration of the attached matrix. Proceed to step 4.

If you logged on using the user password, the program connects you to the matrix switcher with only user capabilities.

If an incorrect password was entered, the program beeps and returns to the password entry display.

Matrix Software, cont'd

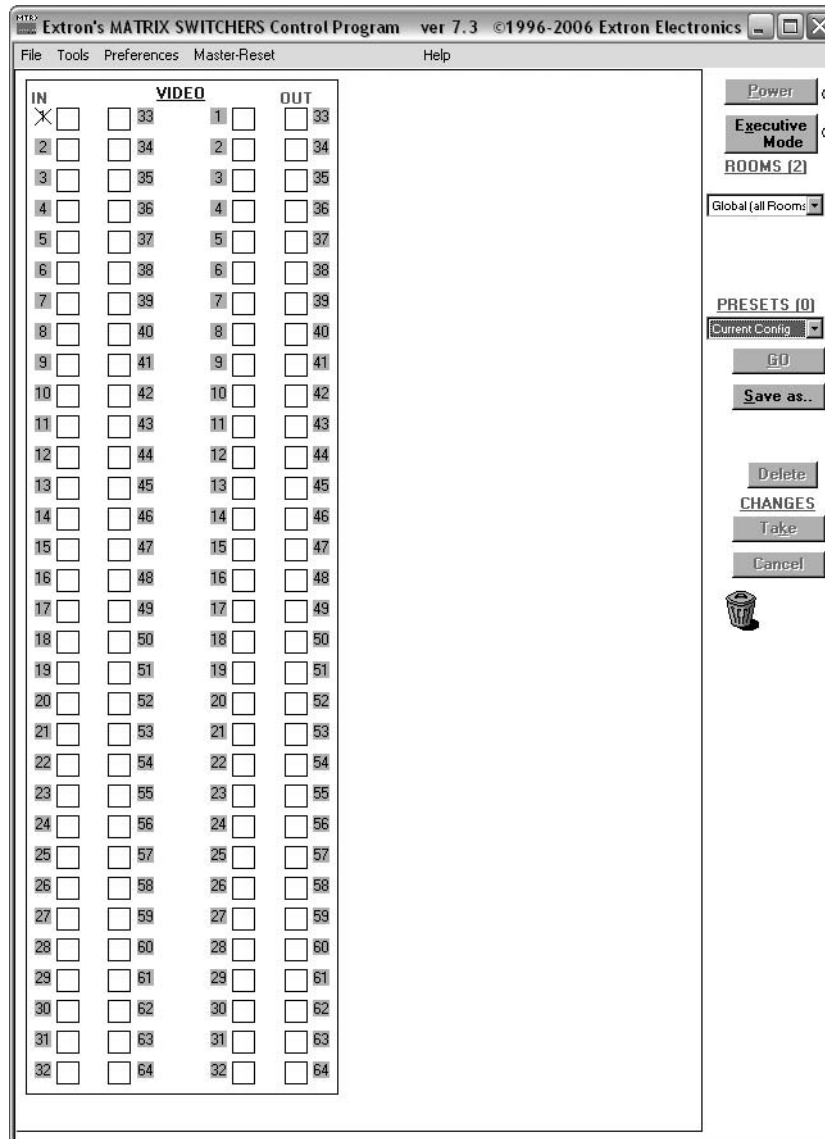

Figure 5-5 — Extron Matrix Switchers Control Program window (blank)

- To create a tie, drag an input box to one or more output boxes. To remove a tie, drag the output box to its tied input box or to the trash can.
 - To make the control program easier to use, assign a device icon to each input and output. Click on a box that represents an input or output, and drag the desired icon onto the box from the icon palette that appears.
 - For quick display of information on a specific input or output device, position the pointer tool over that device in the control program window. The program opens a window that details the connections to that device and the status of the optical link (present or missing) input from or output to that device. See the inset box in figure 5-6.

HINT You can print a map of the current configuration by clicking **File > Print Tie Map**.

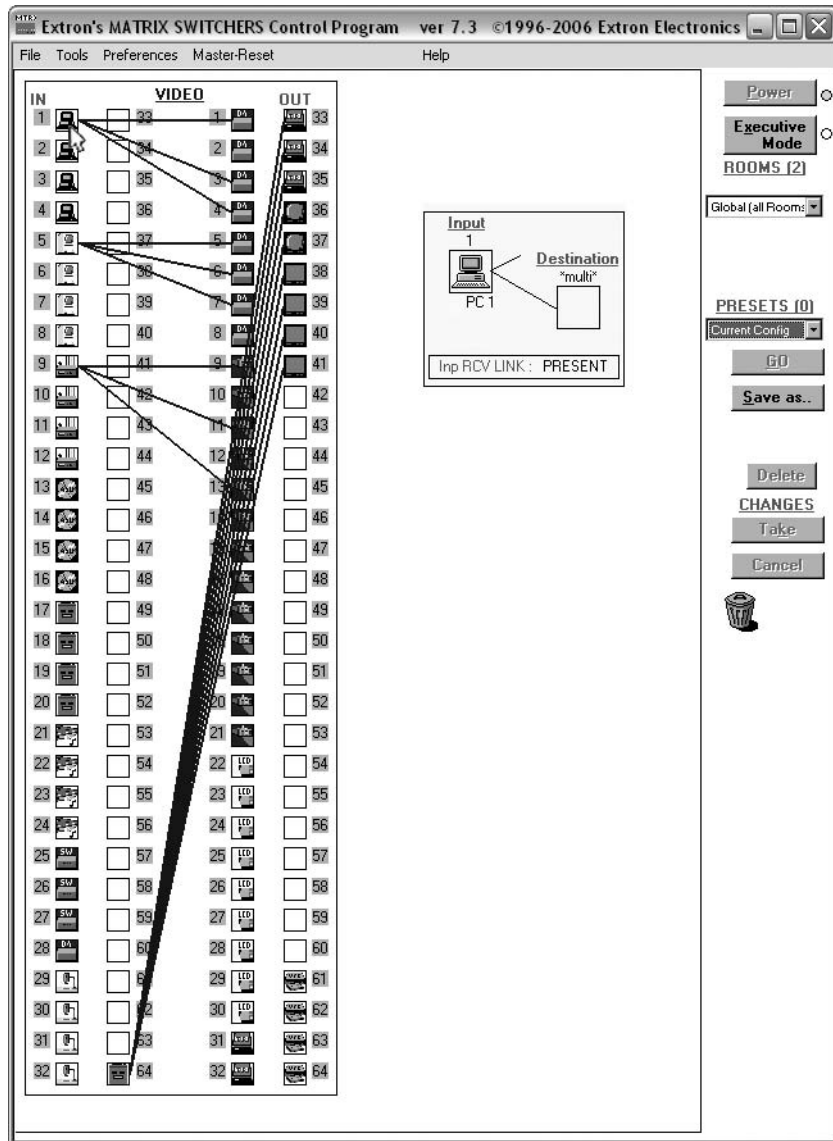

Figure 5-6 — Sample program window (complete)

Matrix Software, cont'd

IP Settings/Options window

The IP Settings/Options window (click **Tools** > **IP options**, figure 5-7) provides a location for viewing and, if connected via either serial port or if logged on via the Ethernet port as an administrator, editing settings unique to the Ethernet interface. See appendix A, "Ethernet Connection", for basic information about IP addresses. None of the fields on this screen can be edited while you are logged on as a user.

The screenshot shows the 'IP Settings/Options' window with the following fields and values:

- Matrix IP Address: 192.168.254.254
- Extron Name/Descriptor: Fiber-Matrix-64-02-FA-AA
- Gateway IP Address: 192.168.0.0
- Subnet Mask: 255.255.0.0
- Hardware Address: 00-05-A6-00-9D-0E
- Use DHCP (Obtain an IP address automatically)
- Date: Wed, 19 Dec 2007
- Time (local): 15:33:31
- Sync time to PC:
- GMT + 8:00:
- Use Daylight Savings:
- Administrator Password: admin
- User Password: user
- Mail Server IP Address: 192.168.2.25
- Domain Name: folklore.net

The 'E-mail Addressee' section contains a table with columns for 'None', 'Fail', 'Fixed', 'Both', 'Missing Input(s)', 'Fans', and 'Power Supply'. The 'Both' column for the first two entries is selected. A 'Send test E-mail' button is located at the bottom right of this section.

At the bottom of the window, it displays 'This PC is: 10.1.4.48 (PROGRAMMER)' and 'Close' and 'Take' buttons.

Figure 5-7 — Control program IP Setting/Options window

NOTE Editing variables in the IP Settings/Options window while connected via the Ethernet port can immediately disconnect the user from the switcher. Extron recommends editing the settings on this screen using the RS-232 link and protecting the Ethernet access to this screen by assigning an administrator's password to qualified and knowledgeable personnel only.

NOTE When the control program is connected to the switcher via the RS-232 link, the Administrator and User Password fields are not masked. If a password has been inadvertently changed to an unknown value, you can look up and, if desired, change the password in this window without knowing the current password.

Address and Name fields

The **Matrix IP Address** field contains the IP address of the connected matrix switcher. This value is encoded in the flash memory in the switcher.

The **Gateway IP Address** field identifies the address of the gateway to the controlling PC to be used if the matrix switcher and the mail server are not on the same subnet.

The **Subnet Mask** field is used to determine whether the matrix switcher is on the same subnet as the controlling PC when you are subnetting. For more information, see “Subnetting — A Primer”, in Appendix A, “Ethernet Connection”.

The **Mail Server IP Address** field displays the IP address of the mail server that handles the e-mail for the facility in which the Fiber Matrix switcher is installed.

Valid addresses consist of four 1-, 2-, or 3-digit numeric subfields, properly called octets, separated by dots (periods). Each field can be numbered from 000 through 255. Leading zeroes, up to 3 digits total per field, are optional. Values of 256 and above are invalid.

The default addresses are as follows, but if these conflict with other equipment at your installation, you can change the addresses to any valid value:

- IP address 192.168.254.254 • Gateway address 0.0.0.0
- Subnet mask 255.255.0.0

NOTE *The address fields are grayed out and uneditable when DHCP is selected.*

NOTE *Editing the addresses while connected via the Ethernet port can immediately disconnect the user from the Fiber Matrix. Extron recommends editing this field using one of the RS-232 ports and protecting the Ethernet access by assigning an administrator’s password to qualified and knowledgeable personnel only.*

The **Extron Name/Descriptor** field contains the name of the matrix switcher. This descriptor can be changed to any valid name, up to 12 alphanumeric characters.

NOTE *The following characters are invalid in the Extron Name/Descriptor field: {space} + ~ , @ = ' [] { } < > ' " ; : | \ and ?.*

The **Mail Server Domain Name** field displays the domain name that the Fiber Matrix switcher uses to log on to the e-mail server. Standard domain conventions (such as xxx.com) apply.

NOTE *The following characters are invalid in a domain name: {space} + ~ , = ' [] { } < > ' " ; : | \ and ?. The @ character is only acceptable as the lead-in to the domain name (such as @folklore.net).*

Edit any of these fields as follows:

1. Click in the desired field. The graphic cursor becomes a text cursor.
2. Edit the address or name as desired.
3. Press the Tab key on the keyboard or click in another field to exit the field.
4. Click the **Take** button to make the address change take affect.

Hardware Address field

The hardware (MAC) address is hardcoded in the switcher and cannot be changed.

Use DHCP checkbox

The Use DHCP checkbox directs the matrix switcher to ignore any entered IP addresses and to obtain its IP address from a Dynamic Host Configuration Protocol (DHCP) server (if the network is DHCP capable). Contact the local system administrator to determine whether to use DHCP.

Matrix Software, cont'd

Date, Time (local), and GMT (offset) fields



The **Date** field displays the current date in the Greenwich Mean Time zone.

The **Time (local)** field displays the current time in the local time zone.

The **GMT** field displays the amount of time, in hours and minutes, that the local time varies from the GMT international time reference.

NOTE *Rather than the following procedure, you can click the **Sync Time to PC** button to set the switcher to your computer's internal time.*

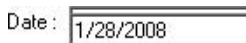
If desired, adjust any of these values as follows:

1. Click in the desired field. The field changes to an editable field appropriate to the value being change and the graphic cursor becomes a text cursor.
 - The **Date** field becomes a set date field, with the date in the format (M)M/(D)D/YYYY. Leading zeroes are not shown. 
 - The **Time (local)** field becomes a set time field, with the time in the format HH:MM:SS (00:00:00 to 23:59:59). 
 - The **GMT** field becomes a set offset field, with the offset in the format ±HH:MM (-12:00 to +14:00). 
2. Edit the field as desired to set the proper proper value. For time, use the 24-hour time standard. Leading zeroes are optional.
3. Press the Tab key on the keyboard or click in another field to exit the set date field.
4. Click the *Take* button to make the date change take affect.

Sync Time to PC button

Clicking the mouse on the **Sync Time to PC** button causes the computer you are operating to send its internal time to the switcher in a set time command.

Use Daylight Savings checkbox

Click in the Use Daylight Savings checkbox. When Daylight Saving Time is turned on, the switcher automatically updates its internal clock between Standard Time and Daylight Saving Time in the spring and fall on the date that the time change occurs in the country or region selected. When Daylight Saving Time is turned off, the switcher does not adjust its time reference.

Administrator Password and User Password fields

The Administrator Password field displays the password required to log on to the matrix switcher via the Ethernet port with all of the administrator's rights and privileges. The User Password field displays the password required to log on to the matrix switcher via the Ethernet port as a user, without all of the administrator's rights and privileges. Passwords are case sensitive and are limited to 12 upper-case and lower-case alphanumeric characters.

While you are logged on as a user, both password fields are masked with asterisks (*****) as a security measure.

NOTE *Editing the Administrator Password field while connected via the Ethernet port can immediately disconnect the user from the switcher. Extron recommends editing this field using either serial port and protecting the Ethernet access to this screen by assigning an administrator's password to qualified and knowledgeable personnel only.*

NOTE An administrator password must be created before a user password can be created.

NOTE The following characters are invalid in passwords:
{space} + ~ , @ = ' [] { } < > ' " ; : | \ and ?.

Edit either password field as follows:

1. Click in the desired Password field. The pointer tool becomes a text cursor.
2. Edit the case-sensitive password as desired.
3. Press the Tab key on the keyboard or click in another field to exit the Password field.
4. Click the **Take** button to make the password change take effect.

E-mail Addressee fields

The eight E-mail Addressee fields permit the administrator to identify the e-mail addresses of the personnel to whom the matrix switcher e-mails notification of its failure and repair status. The following figure shows a typical e-mail from the switcher.

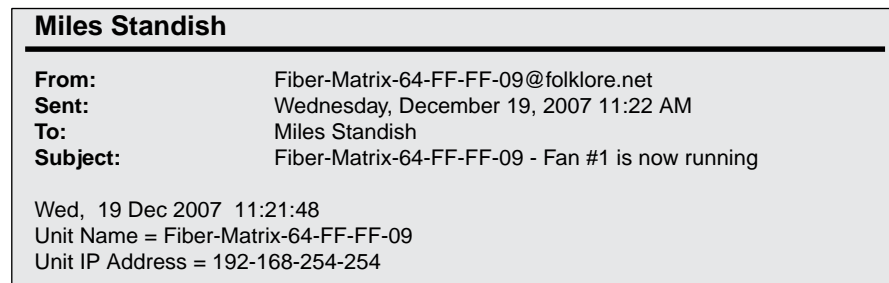

The radio buttons and check boxes associated with each address field permit the administrator to specify e-mail requirements for each recipient.

Edit these fields and controls as follows:

1. Click in the desired E-mail Addressee field. The pointer tool becomes a text cursor.
2. Edit the e-mail address as desired. Standard e-mail address conventions apply (for example: *nnnnn@xxx.com*).
3. Press the Tab key on the keyboard or click in another field to exit the e-mail addressee field.
4. In the square check boxes associated with each addressee, select the options about which the addressee is to be e-mailed: missing input(s), fans, and/or power supply. In the floating box that contains the input numbers, select the inputs to be monitored.
5. In the round radio buttons associated with each addressee, select whether the addressee is to be e-mailed of failures, fixes, both, or not be notified. The None radio button is useful for temporarily removing personnel from the e-mail list when they are unavailable, such as on travel or vacation.
6. If desired, click on the **Send test E-mail** button to test the e-mail function.
7. Click on the **Take** button to make the e-mail address changes take effect.

Matrix Software, cont'd

Updating firmware

The firmware upgrade utility provides a way to replace the firmware that is coded on the switcher's control board without taking the switcher out of service.

Update the switcher firmware as follows:

1. Visit the Extron Web site, www.extron.com, click the **Download** tab, and then click the **Firmware** link (figure 5-8).

NOTE This sequence is shown for example only. For the Fiber Matrix 6400, the firmware file selected and shown is "Fiber Matrix 6400".

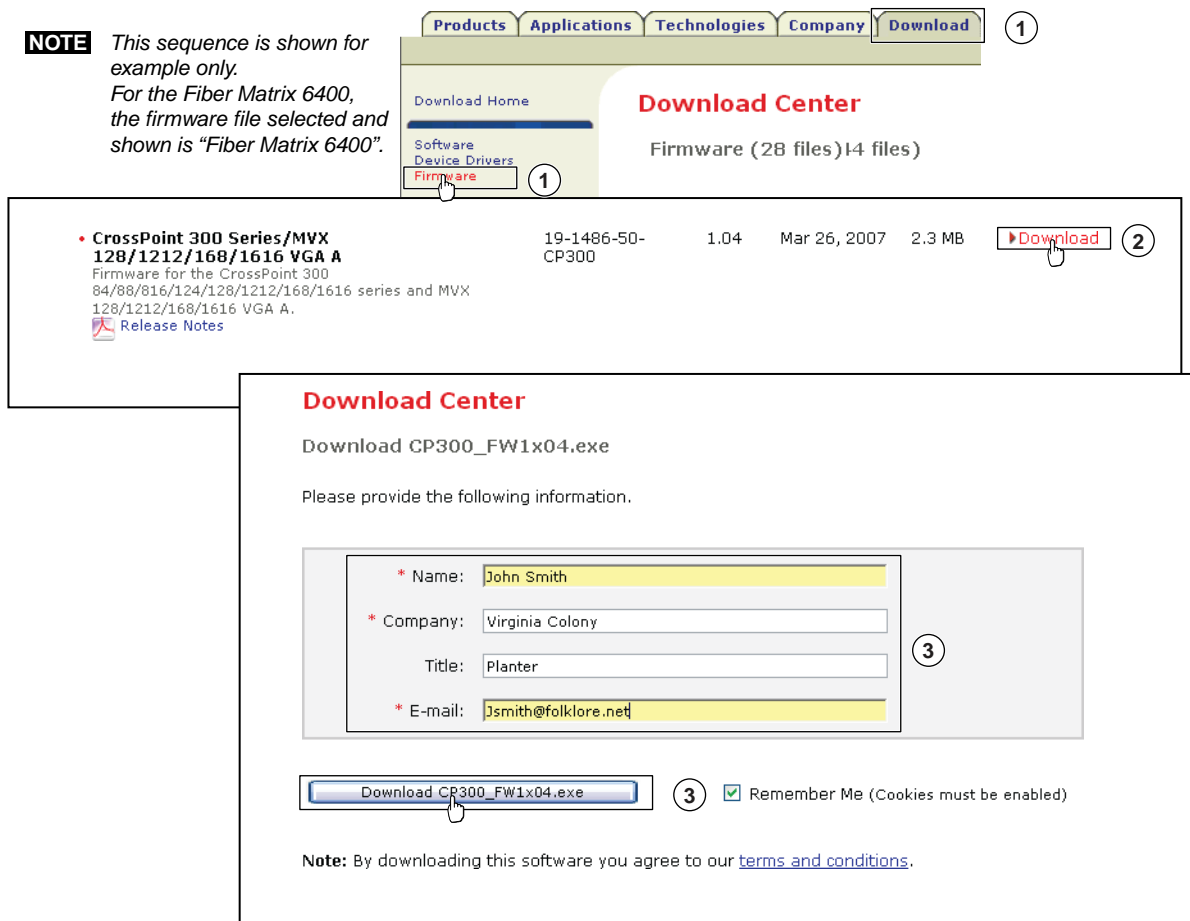

Figure 5-8 — Location of firmware upgrade files

2. Select the appropriate firmware file (Fiber Matrix 6400) to download and click **Download**.
3. Enter the requested personal information and then click **Download** to copy the firmware to your computer.
4. Click **Run** twice (figure 5-9 on the next page). The PC downloads the firmware update from the Extron Web site and starts the Extron Installation Program to extract the firmware file.
5. Click **Next**. The program extracts the firmware files and places them in a folder identified in the InstallShield Wizard window.

NOTE Note the folder to which the firmware file is saved.

6. Click **Finish** to exit the program.

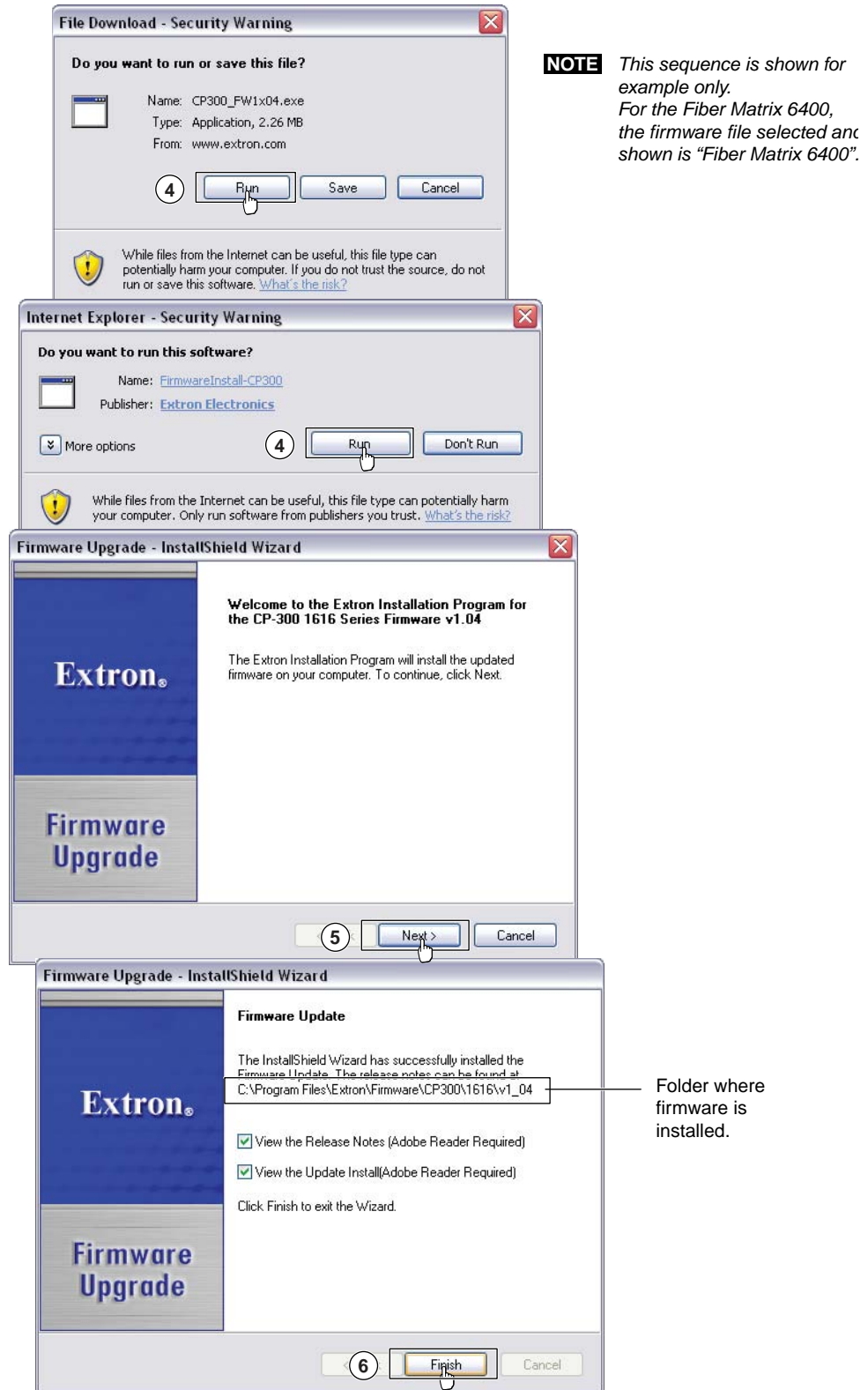

Figure 5-9 — Downloading firmware upgrade files

Matrix Software, cont'd

7. Connect a Windows-based computer to either switcher serial port or the switcher LAN port. See chapter 2, "Installation", for more details.
8. Start the Matrix Switchers Control Program and connect to the matrix switcher. See "Using the Matrix Switcher Control software" in this chapter, steps 1 through 4, starting on page 5-4.
9. Click **Tools > Update firmware**.

If you are connected via the LAN port, the Select Files window appears (figure 5-10). See "Ethernet-connected firmware upload", below.

If you are connected via either serial port, the Extron Firmware Loader appears (figure 5-11). See "Serial-port-connected firmware upload", on the next page.

Ethernet-connected firmware upload

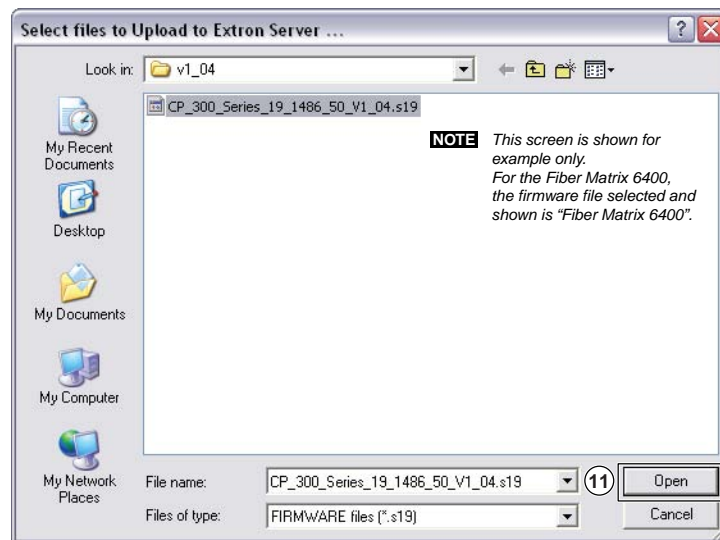

Figure 5-10 — Select files window

10. Navigate to the folder where you saved the firmware upgrade file. Select the file.

NOTE Valid firmware files must have the file extension *.S19*. Any other file extension is not a firmware upgrade.

NOTE The original factory-installed firmware is permanently available on the Fiber Matrix switcher. If the attempted firmware upload fails for any reason, the switcher reverts to the factory-installed firmware.

11. Click the **Open** button. The software advises you that you are about to reprogram the switcher's firmware. Click **OK** to continue.

A status window, which shows the progress of the upload, appears. The firmware upload to the Fiber Matrix switcher may take a few minutes. When the upload is complete, the program closes.

Serial-port-connected firmware upload

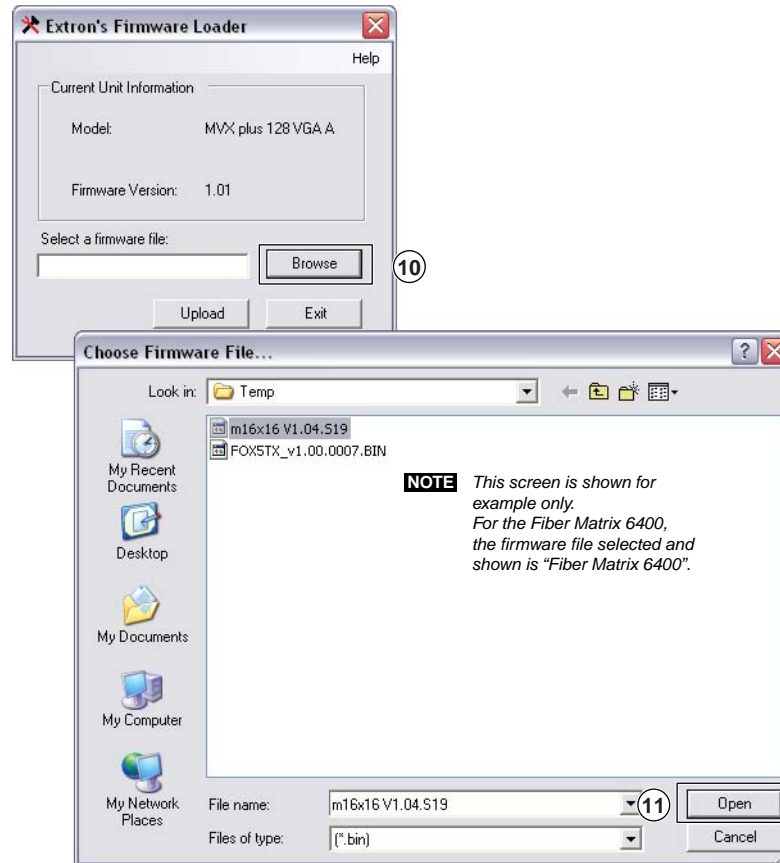

Figure 5-11 — Firmware loading

10. Click **Browse**. The open file window appears.
11. Navigate to the folder where you saved the firmware upgrade file. Select the file and click **Open**. The Firmware Loader window returns to the top.

NOTE Valid firmware files must have the file extension ".S19". Any other file extension is not a firmware upgrade for your matrix switcher.

12. Click **Upload**. The File Loader advises you that using the Ethernet (LAN) port is preferred over using either serial port (figure 5-12).

To quit the firmware upload and start over using the LAN port, click the **Cancel** button and return to step 3. Use the LAN port connection in step 3.

To continue the firmware upload using either serial port connection, click the **OK** button. The program prompts you to identify the serial port to which you are connected. Continue to step 13.

Matrix Software, cont'd

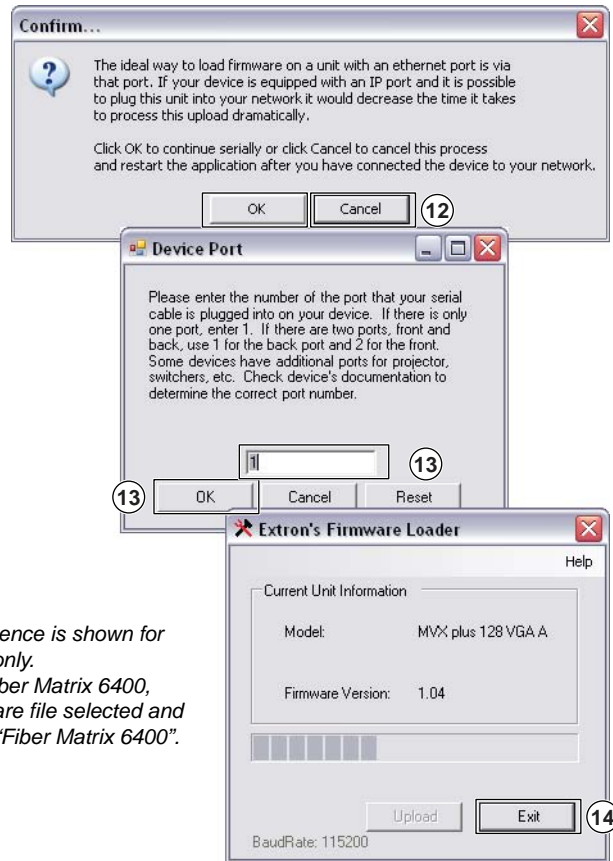

NOTE This sequence is shown for example only.
For the Fiber Matrix 6400, the firmware file selected and shown is "Fiber Matrix 6400".

Figure 5-12 — Confirm window

13. If necessary, change the port number in the device port field:

- Rear panel RS-232/RS-422 port, enter 1.
- Front panel Configuration port, enter 2.

Click the **OK** button. The Firmware Loader reports, "This process could take several minutes. Please wait...", then displays a status bar that shows the progress of the upload. When the upload is complete, the Firmware Loader reports "Unit resetting, this can take some time, please wait. ...", and then "Transfer complete!".

NOTE Firmware upgrades using either serial port can take several minutes.

14. When the Firmware Loader reports, "Transfer complete!", click the **Exit** button on the Firmware Loader and then again on the port configuration window. The Firmware Loader and the Matrix Switchers Control Program close.

Uploading HTML files

You can create customized HTML pages for the switcher to display. The HTML Files List window (figure 5-13), accessible via the Tools menu, provides a way to view the contents of the switcher's file system and upload custom HTML pages to the switcher.

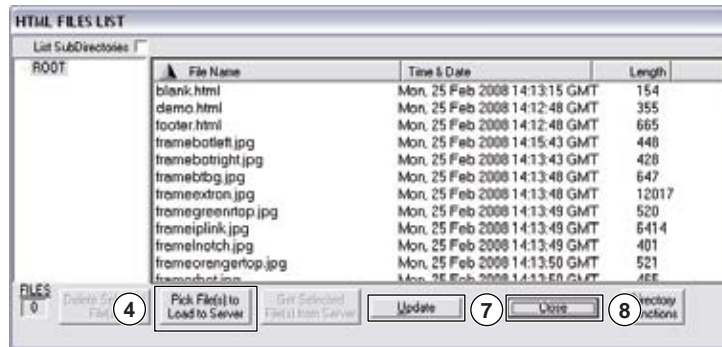

Figure 5-13 — HTML Files List window

Upload HTML pages as follows:

NOTE The files listed in figure 5-13 are shown for example only and may not be present on your switcher.

NOTE The HTML Files List window is for inserting your own HTML pages. This is **not** the window to replace the firmware that controls all switcher operation. See "Updating firmware" in this chapter to replace the firmware.

NOTE The following characters are invalid in file names:
{space} + ~ , @ = ' [] { } < > ' " ; : | \ and ?.

1. Connect the PC to the matrix switcher via the switcher's RS-232/RS-422 port or Ethernet port.
2. Start the Matrix Switchers Control Program and connect to the Fiber Matrix switcher. See "Using the Matrix Switcher Control software" in this chapter, steps 1 through 4, starting on page 5-4.
3. Click on **Tools > HTML File Manager**.
4. Click the **Pick File(s) to Load to Server** button. An open file window appears.
5. Navigate to the folder where you saved the HTML file(s). Select the file(s).

NOTE To select multiple files, hold the Ctrl key while you select the desired files.

NOTE If you want one of the HTML files that you created to be the default start-up page, name the file "index.html". The Fiber Matrix switcher automatically looks for that file name when you first connect to it using an Internet browser.

6. Click the **Open** button. The file(s) upload to the Fiber Matrix switcher may take a few minutes.
7. Click the **Update** button to confirm the upload.
8. Click the **Close** button to exit the HTML Files List window.

Matrix Software, cont'd

Windows buttons, drop boxes, and trash can

The buttons, drop boxes, and trash can on the right side of the Matrix Switchers Control Program window perform the following functions:

Power — Unavailable for Fiber Matrix switchers, because the switcher power cannot be controlled via software.

Executive Mode — Allows you to lock out front panel operations, except for the view-only mode functions. Click the button to cycle between *Lock mode 0* (the indicator is white), *Lock mode 1* (the indicator displays red), and *Lock mode 2* (orange).

NOTE See “Locking out the front panel (Executive modes)” in chapter 3, “Operation” for more information on the Lock modes.

Rooms menu — Displays a list of up to 10 rooms. You can select a room from the list to display it in the window.

NOTE A *Room* is a subset of outputs that are logically related to each other, as determined by the operator. The Fiber Matrix switcher supports up to 10 rooms, each of which can consist of from 1 to 16 outputs.

Presets menu — Displays a list of up to 64 global presets and up to 100 room presets (10 rooms x 10 presets per room). You can select a preset from the list to display it in the window and either activate it (Go) or delete it (Delete).

Go — Activates the selected preset as the current configuration.

Save as ... — Allows the current set of ties to be saved as a preset. Enter the preset number when prompted to do so.

Delete — Allows the current preset to be deleted.

Changes – Take — Allows you to save to file any changes made to the displayed configuration.

Changes – Cancel — Returns to the previous screen, undoing any changes you have made.

Trash can — Drag and drop from an input or output button to the trash can to erase all ties associated with that input or output.



Windows menus

File menu

Save Matrix settings as ... — Saves a complete set of up to 64 presets, plus the last active setting (preset #0), to a file. Saved settings include assigned icons and icon captions.

Restore Matrix settings from ... — Loads and activates a previously saved setting file.

Save This-Session's settings — Saves the current assigned icons and icon captions.

Restore Last-Session's settings — Loads the icons and icon captions that were saved during the last session. If you saved the previous session's changes to disk the last time you exited the program, the ties from that session are also loaded.

Select printer — Selects the target printer from a list of connected printers.

Print tie map — Prints the tie set that is displayed on the screen.

Exit — Closes the Matrix Switchers Control Program.

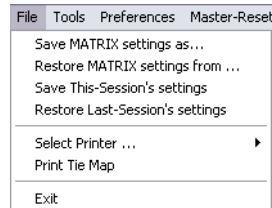

Tools menu

Assign Device Icons — Displays the complete set of input and output device icons. You can drag any of these icons to the input and output boxes.

Edit Device Palette — Allows you to add your own device icon graphics.

Mute-Outputs settings — Displays the Mute Adjust screen, from which you can mute each output.

HD/SDI Reclocker settings — Displays the Channel Mute and Rate Settings screen, from which you can select between the automatic re-clocking rate or bypass reclocking for SDI/HD-SDI inputs only.

View Input Frequencies — Displays the Input Detection screen, which shows the data rates for SDI/HD-SDI inputs only.

Update Firmware — Allows you to replace the firmware that is coded on the switcher's control board without taking the switcher out of service, opening the switcher enclosure, and replacing the firmware chip set. See "Updating firmware" on page 5-12.

IP options — Allows you to set IP options. See "IP Settings/Options window" on page 5-8.

Hardware status — Provides an overall view of the status of the matrix switcher, including the power supply voltages, the temperature status, the Remote RS-232/RS-422 port configuration, and the installed and updated firmware status (figure 5-14).

Tools	Preferences	Master-Reset
Assign Device Icons		
Edit Device Palette		
RGB Delay settings		
Audio-Input Gain settings		
Audio-Output Volume settings		
Mute-Output settings		
HD/SDI Re-clocker settings		
View Input Frequencies		
Update Firmware ...		
IP Options		
HTML File Manager		
Hardware Status		
Physical Switcher Layout		
Name Presets		
Show RS-232 Strings		
I/O Group settings		
Room configuration		
Initialize ...		

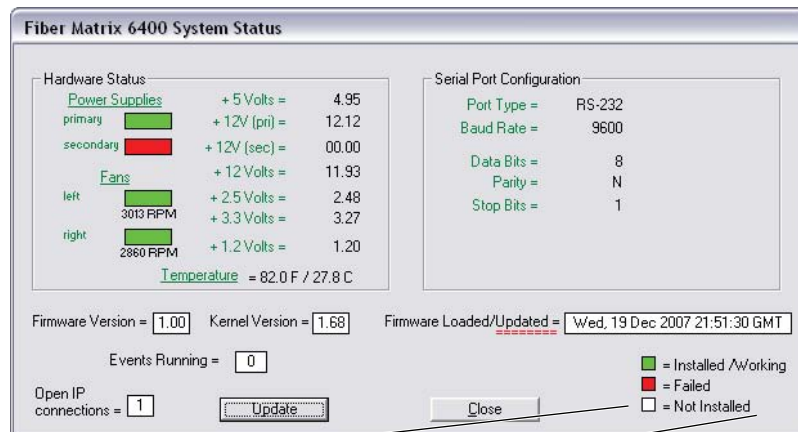

- = Installed / Working Green — Proper operation.
- = Failed Red — Component has failed.
- = Not Installed White — **Not a valid report for the Fiber Matrix.**

Figure 5-14 — Status window

Matrix Software, cont'd

Physical Switcher Layout — Opens the Fiber Matrix 6400 Physical Configuration window (figure 5-15), which displays the I/O board type installed in each slot. The Channels field can be helpful in identifying a specific input or output. In figure 5-15, for example, input 49 is identified as slot 7, input transceiver 1 (7i01).

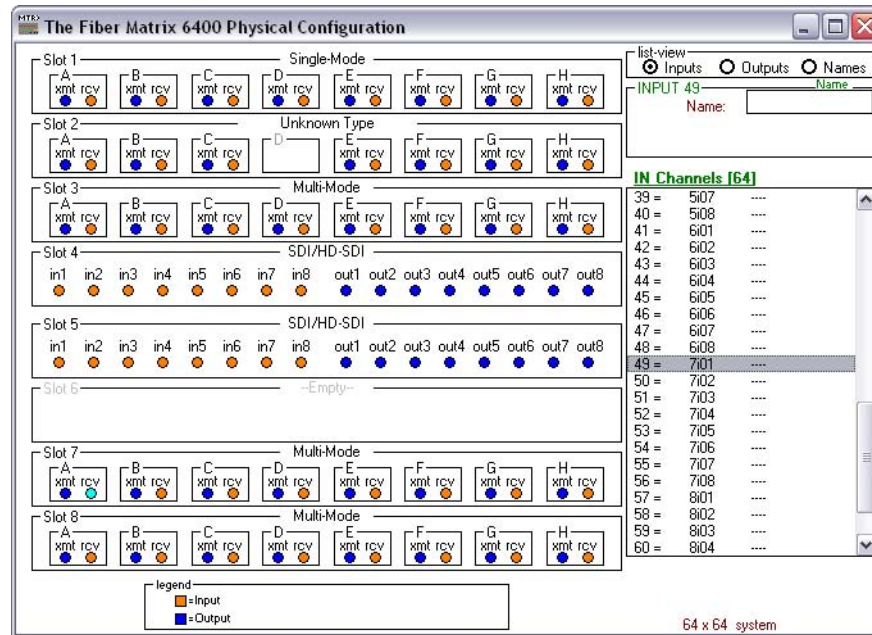

Figure 5-15 — Physical Configuration window

Name presets — Allows you to assign a name to each of the 64 memory presets.

NOTE Preset names are limited to 12 upper- and lower-case alphanumeric characters, space, and the `_` and `/` characters.

The following characters are invalid in preset names:
`+ ~ , @ = ' [] { } < > ' " ; : | \ and ?.`

Show RS-232 Strings — Displays the ASCII commands that are used by the current configuration. You can refer to these for SIS programming.

I/O group settings — Allows you to establish I/O groups.

Room configuration — Allows you to assign outputs to rooms or delete outputs from rooms.

NOTE A Room is a subset of outputs that are logically related to each other, as determined by the operator. The Fiber Matrix switcher supports up to 10 rooms, each of which can consist of from 1 to 16 outputs.

Initialize — Initializes and clears any or all of the following: ties, presets, preset names, icon names, and icons.

Preferences menu

Immediate Changes — Causes configuration changes to take effect immediately.

Hold/verify Changes — Delays implementation of configuration changes until the Changes – **Take** button is clicked.

Ties as Lines — Displays ties as lines (below).

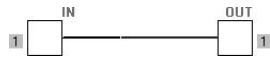

Ties as Crosspoints — Displays ties as a matrix of inputs and outputs (figure 5-16). Ties that have been made are indicated as **amber** or **green** boxes. Ties that will take effect when you click the **Take** button are indicated by +. Ties that will be broken when you click the **Take** button are indicated by –.

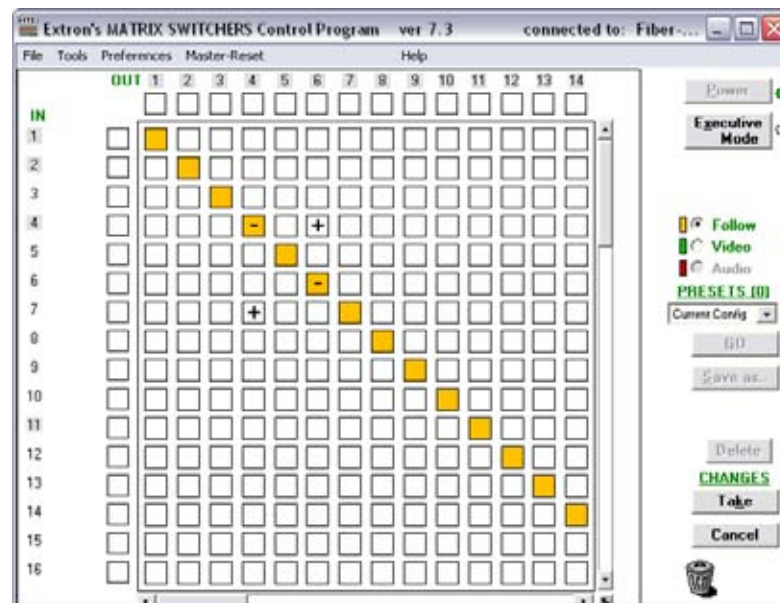
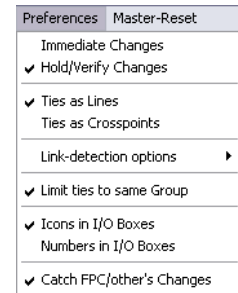

Figure 5-16 — Ties shown as crosspoints

Link-detection options — Allows you to set the link detection feature as follows:

- To automatically refresh the display every 10 seconds.
- To update the display whenever you refresh the screen.
- To never sample and display the link status

Icons in I/O Boxes — Erases any numbers in the I/O boxes in the Control Program window (figure 5-6). You can place icons in the boxes.



Numbers in I/O Boxes — Erases any icons in the I/O boxes in the Control Program window and fills each box with the associated input or output number.



Master-Reset selection

Master reset clears all ties and presets, all output mutes, and resets all I/O grouping.

Master-Reset

NOTE Master reset does not reset the Internet protocol (IP) settings.

Matrix Software, cont'd

Using Emulation mode

Emulation mode allows you to set up the software without attaching the switcher to the computer. To use Emulation mode, do the following:

1. Double-click the Matrix Switchers Control Program icon in the Extron Electronics group or folder.
2. Choose **Emulate**, and click **OK**.
3. Choose an emulation file to open, and click **OK**. The file DEMO.MTX provides a sample of a completed matrix setup. Selecting the file NEW.INI or clicking **Cancel** provides a blank setup to get you started.
4. Enter the file name under which you want to save any changes to the file, and click **OK**.
5. Select **Fiber Matrix** as the Matrix Model, **6400** as the Default Size (figure 5-17); check the boards that are installed; and select the type, **singlemode**, **multimode**, or **BNC**, for each board. Click **OK**.

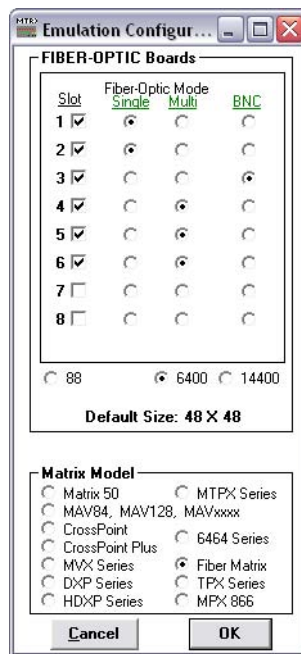

Figure 5-17 — Emulation mode configuration

6. Continue using the program as described on page 5-7.

Using the help system

For information about program features, you can access the help program in any of the following ways:

- From the Extron Electronics program folder or group, double-click on the MATRIX Switcher Help icon (shown at right).
- From within the Matrix Switchers Control Program, click on the Help menu on the main screen.
- From within the Matrix Switchers Control Program, press the F1 key.



Button-Label Generator Program

The Button Label Generator software creates labels that you can place in the translucent covers above and below the input and output pushbuttons. You can create labels with names, alphanumeric characters, or even color bitmaps for easy and intuitive input and output selection. See chapter 7, “Maintenance and Modifications”, for the procedure for removing and replacing the translucent covers.

Installing the Button-Label Generator software

The Extron Button Label Generator is available on the Extron Web site, www.extron.com, under the Download tab. Click the **Software** link (figure 5-18), and download and install the program.



Figure 5-18 — Location of software on the web site

NOTE *The Button Label Generator software is also included on the Extron Software Products disk that accompanied the switcher.*

By default, the Windows installation creates a C:\Program Files\Extron\ButtonLabelGenerator directory and places the Button Label Generator icon into a group or folder named “Extron Electronics”.

Matrix Software, cont'd

Using the Button-Label Generator software

1. To run the Button-Label Generator program, click **Start > Programs > Extron Electronics > Button Label Generator > Button Label Generator**. The Button-Label Generator window appears (figure 5-19).

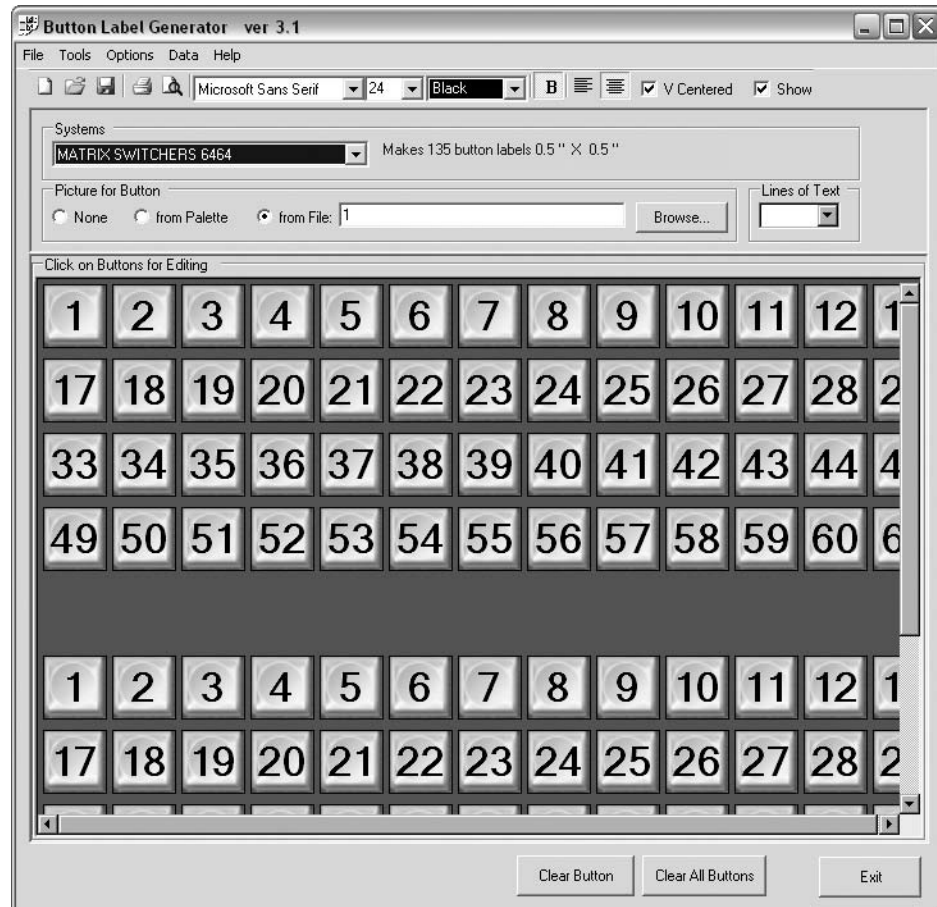

Figure 5-19 — Extron's Button-Label Generator window

2. In the Systems selection box, choose the Matrix Switchers 6464 option to match the button label size and quantities for your Fiber Matrix switcher.
3. Using standard Windows controls, you can create and print labels that can be placed in the clear button caps on the front panel of the switcher.
4. Click the **Clear All Buttons** button and create new labels as many times as necessary to make all of the button labels that you need.

To access the help program, click the Help menu.



Fiber Matrix 6400 Switcher

6 Chapter Six

HTML Operation

Opening the Switcher's Embedded Web Pages

Status Tab

Configuration Tab

File Management Tab

Special Characters

HTML Operation

The switcher can be controlled and operated through its LAN port, connected via a LAN or WAN, using a web browser such as Microsoft® Internet Explorer®. The browser's display of the switcher's status or operation has the appearance of web pages. This chapter describes the factory-installed HTML pages, which are always available and cannot be erased or overwritten.

NOTE *If your Ethernet connection to the matrix switcher is unstable, try turning off the proxy server in your Web browser. In Internet Explorer, click **Tools** > **Internet Options** > **Connections** > **LAN Settings**, uncheck the **Use a proxy server...** box, and then click **OK**.*

Opening the Switcher's Embedded Web Pages

Access the switcher using HTML pages as follows:

1. Start the Web browser program.
2. Click in the browser's Address field.
3. Enter the Matrix IP address in the browser's Address field.

NOTE *If the local system administrators have not changed the value, the factory-specified default, 192.168.254.254, is the correct value for this field.*

4. If you want the browser to display a page other than the default page (such as a custom page that you have uploaded), enter a slash (/) and the file name to open after the IP address.

NOTE *The browser's Address field should display the address in the following format: xxx.xxx.xxx.xxx/{optional_file_name.html}*

NOTE *The following characters are invalid in file names: {space} + ~ , @ = ' [] { } < > ' " ; : | \ and ?.*

5. Press the keyboard Enter key. The switcher checks to see if it is password protected.

If the switcher is not password protected, it checks and downloads the HTML pages (proceed to step 7).

If the switcher is password protected, the computer displays the Connect To dialog box (figure 6-1).



Figure 6-1 — Enter Network Password page

NOTE *A User name entry is not required.*

6. Click in the Password field and type in the appropriate administrator or user password. Click the **OK** button.

NOTE *A User name entry is not required.*

7. The switcher checks several possibilities, in the following order, and then responds accordingly:
 - a. Does the address include a specific file name, such as 10.13.156.10/file_name.html? **If so**, the switcher downloads that HTML page.
 - b. Is there a file in the switcher’s memory that is named “index.html”? **If so**, the switcher downloads “index.html” as the default startup page.
 - c. **If neither of the above conditions is true**, the switcher downloads the factory-installed default startup page, “nortxe_index.html” (figure 6-2), also known as the System Status page.

Status Tab

System Status page

The System Status page (figure 6-2) provides an overall view of the status of the matrix switcher, including individual voltages, and the serial port status (if applicable). The System Status page is the default page that the switcher downloads when you connect to the switcher. Access the System Status page from other pages by clicking the **Status** tab.

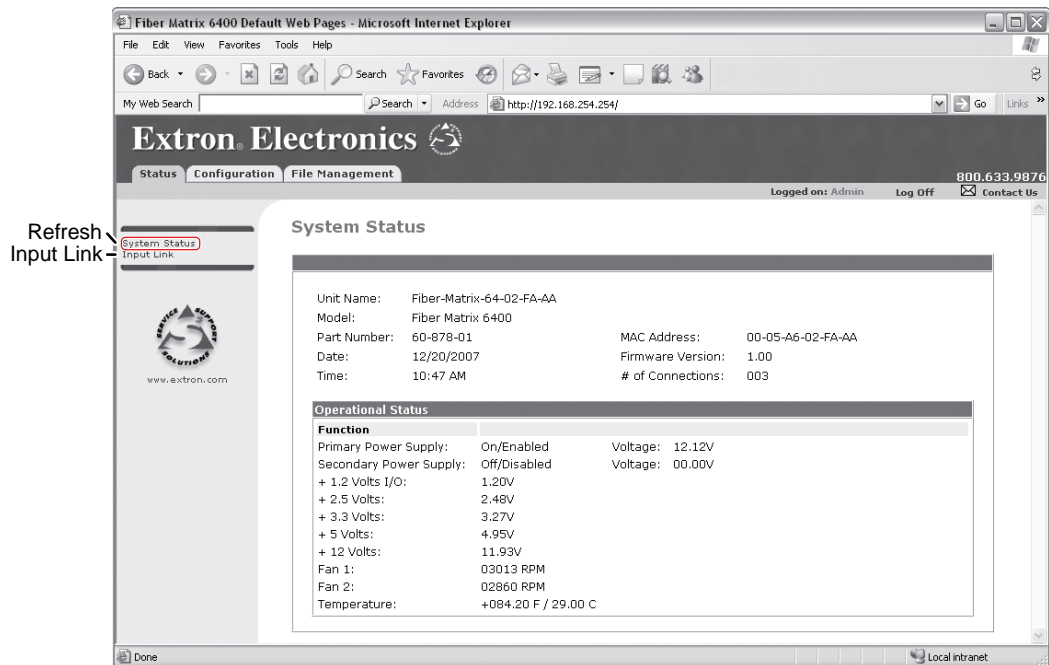

Figure 6-2 — System Status page

The status web page periodically updates itself to reflect the latest status of the switcher components. If a variable changes, the display shows the change the next time it updates.

HTML Operation, cont'd

Input Link page

You can view the status of each I/O board slot on the Input Link page (figure 6-3). Click the **Input Link** link to the left of the Status page to download the Input Link page. The Input Link page automatically updates itself every 30 seconds to show the latest status of installed boards, LC connector installation, and input signal presence.

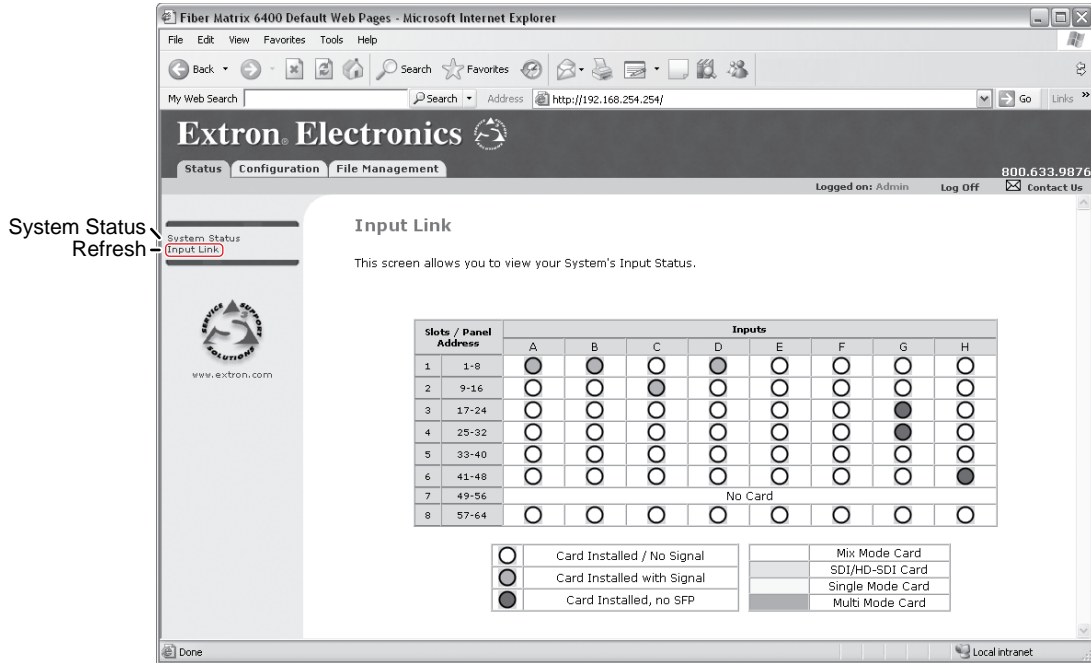

Figure 6-3 — Input Link page

Configuration Tab

System Settings page

The Fiber Matrix switcher downloads the System Settings page (figure 6-4) when you click the **Configuration** tab. The screen consists of fields in which you can view and edit IP administration and system settings. You can access the Email Settings and Passwords pages by clicking the appropriate link. See appendix A, “Ethernet Connection”, for basic information about IP addresses and subnetting.

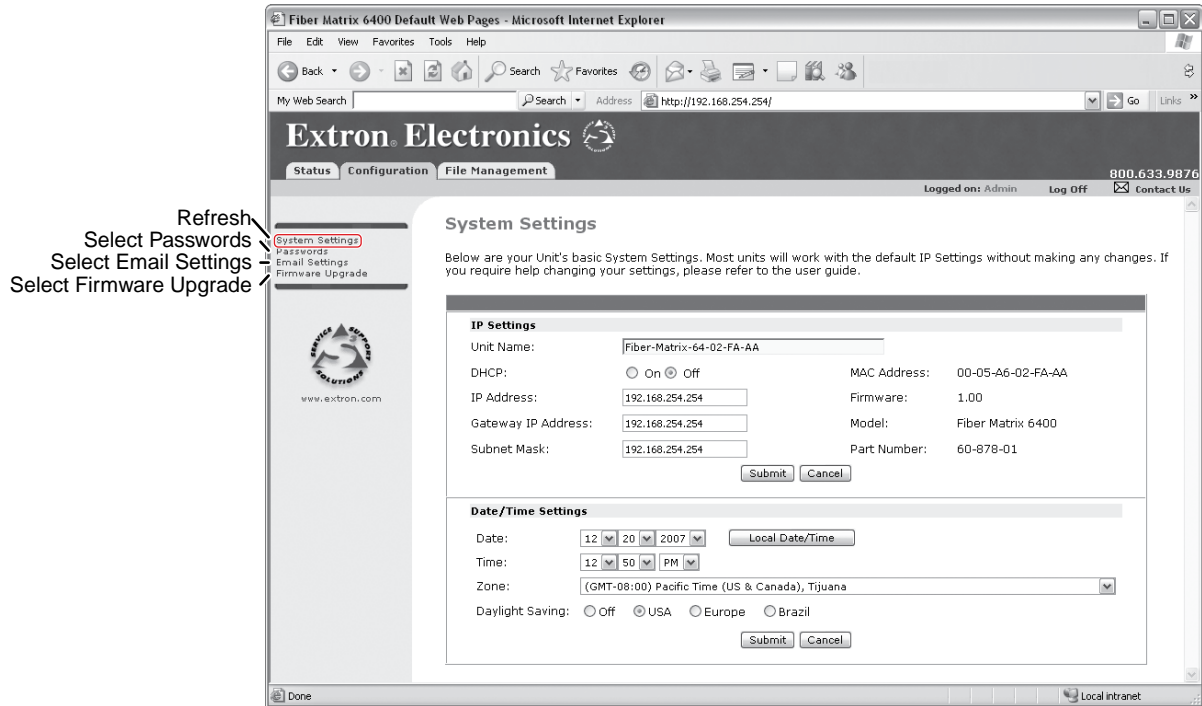

Figure 6-4 — System Settings page

On password-protected connections, there are two levels of protection: administrator and user. Administrators have full access to all switching capabilities and editing functions. Users can create ties, create and recall presets, set output mutes, and view all settings with the exception of passwords.

IP Settings fields

The IP Settings fields provide a location for viewing and editing settings unique to the Ethernet interface. After editing any of the settings on this page, click the **Submit** button at the bottom of the page.

Unit Name field

The Unit Name field contains the name used as the “from” information when the switcher e-mails notification of its failed or repaired status. This name field can be changed to any valid name, up to 24 alphanumeric characters.

NOTE *The following characters are invalid in the matrix name:
+ ~ , @ = ' [] { } < > ' " ; : | \ and ?.*

HTML Operation, cont'd

DHCP radio buttons

The DHCP On radio button directs the switcher to ignore any entered IP addresses and to obtain its IP address from a Dynamic Host Configuration Protocol (DHCP) server (if the network is DHCP capable). The DHCP Off radio button turns DHCP off. Contact the local system administrator to determine if DHCP is appropriate.

IP Address field

The IP Address field contains the IP address of the connected switcher. This value is encoded in the switcher's flash memory.

Standard IP protocol consists of addresses comprised of four 1-, 2-, or 3-digit numeric subfields, properly called octets, separated by dots (periods). Each octet can be numbered from 000 through 255. Leading zeroes, up to 3 digits total per octet, are optional. Values of 256 and above are invalid.

The factory-installed default address is 192.168.254.254, but if this conflicts with other equipment at your installation, you can change the IP address to any valid value.

NOTE *IP address changes can cause conflicts with other equipment. Only local system administrators should change IP addresses.*

Gateway IP Address field

The Gateway IP Address field identifies the address of the gateway to the mail server to be used if the switcher and the mail server are not on the same subnet. Standard IP protocol rules apply to the Gateway IP address

Subnet Mask field

The Subnet Mask field is used to determine whether the switcher is on the same subnet as the mail server when you are subnetting. For more information, see "Subnetting — A Primer", in appendix A, "Ethernet Connection".

MAC Address field

The Media Access Control (MAC) Address is hardcoded in the switcher and cannot be changed.

Firmware field

The Firmware field identifies the installed firmware version. This field is hardcoded in the switcher and cannot be changed.

Model field

The Model field identifies the number of inputs and outputs. This field is hardcoded in the switcher and cannot be changed.

Part Number field

The Part Number field identifies the part number of your switcher. This field is hardcoded in the switcher and cannot be changed.

Date/Time Settings fields

The Date/Time Settings fields (figure 6-5) provide a location for viewing and setting the time functions.

The screenshot shows the 'Date/Time Settings' interface. It includes fields for Date (Month: 12, Day: 21, Year: 2007), Time (Hour: 7, Minute: 56), Zone (GMT-08:00), and Daylight Saving (On). A 'Local Date/Time' button is present. A scrollable list of years from 2000 to 2010 is shown on the right, with 2007 selected. Below the Zone field, there are radio buttons for 'Europe' and 'Brazil'. 'Submit' and 'Cancel' buttons are at the bottom right.

Figure 6-5 — Date/Time Settings fields

Change the date and time settings as follows:

1. Click the desired variable's drop box. The adjustable variables are month, day, year, hours, minutes, AM/PM, and (time) zone. A drop-down scroll box appears (the year drop box is selected in figure 6-5).
2. Click and drag the slider or click the scroll up ▲ button or the scroll down ▼ button until the desired variable is visible.
3. Click the desired variable.

NOTE *If setting the time, set the local time. The Zone variable allows you to then enter the offset from Greenwich Mean Time (GMT).*

NOTE *The Zone field identifies the standard time zone selected and displays the amount of time, in hours and minutes, that the local time varies from the GMT international time reference.*

4. Repeat steps 1 through 3 for other variables that need to be changed.
5. If appropriate, select the appropriate Daylight Saving radio button to turn on the daylight savings time feature for your region or nation.

NOTE *When Daylight Saving Time is turned on, the switcher automatically updates its internal clock between Standard Time and Daylight Saving Time in the spring and fall on the date that the time change occurs in the country or region selected. When Daylight Saving Time is turned off, the switcher does not adjust its time reference.*

6. Click the **Submit** button.

HTML Operation, cont'd

Passwords page

Access the Passwords page (figure 6-6) by clicking the Passwords link on the System Settings page.

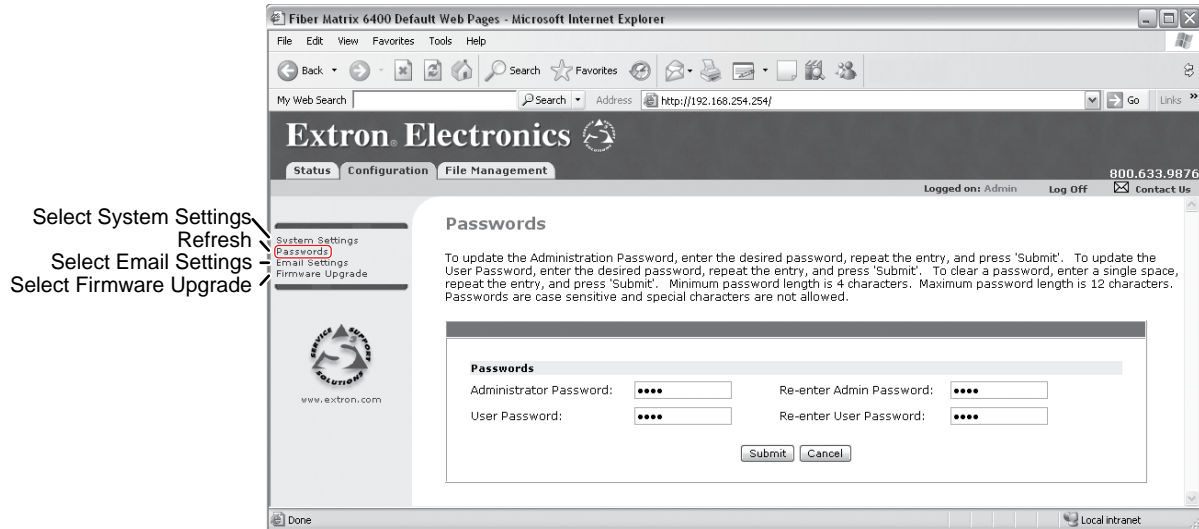

Figure 6-6 — Passwords page

The fields on the Passwords page are for entering and verifying administrator and user passwords. Passwords are case sensitive and are limited to 12 upper-case and lower-case alphanumeric characters. Each password must be entered twice; once in the Password field and then again in the Re-enter Password field. Characters in these fields are masked by asterisks (*****). If you do not want to password protect an access level, leave the Password field and the Re-Enter password field blank. After entering the desired password in both fields, click the **Submit** button.

NOTE *An administrator password must be created before a user password can be created.*

To clear an existing password so that no password is required, clear any existing password, enter a single space character in the Password and Re-enter Password fields, and click the **Submit** button.

Email Settings page

Access the Email Settings page (figure 6-7) by clicking the Email Settings link on the System Settings page. The Email Settings page has fields for setting up the switcher's e-mail notification capabilities. For the e-mail settings and for each row of the e-mail notification settings, click the **Edit** button to make the fields available for editing. The button changes to **Save**. After editing the associated settings with, click the **Save** button.

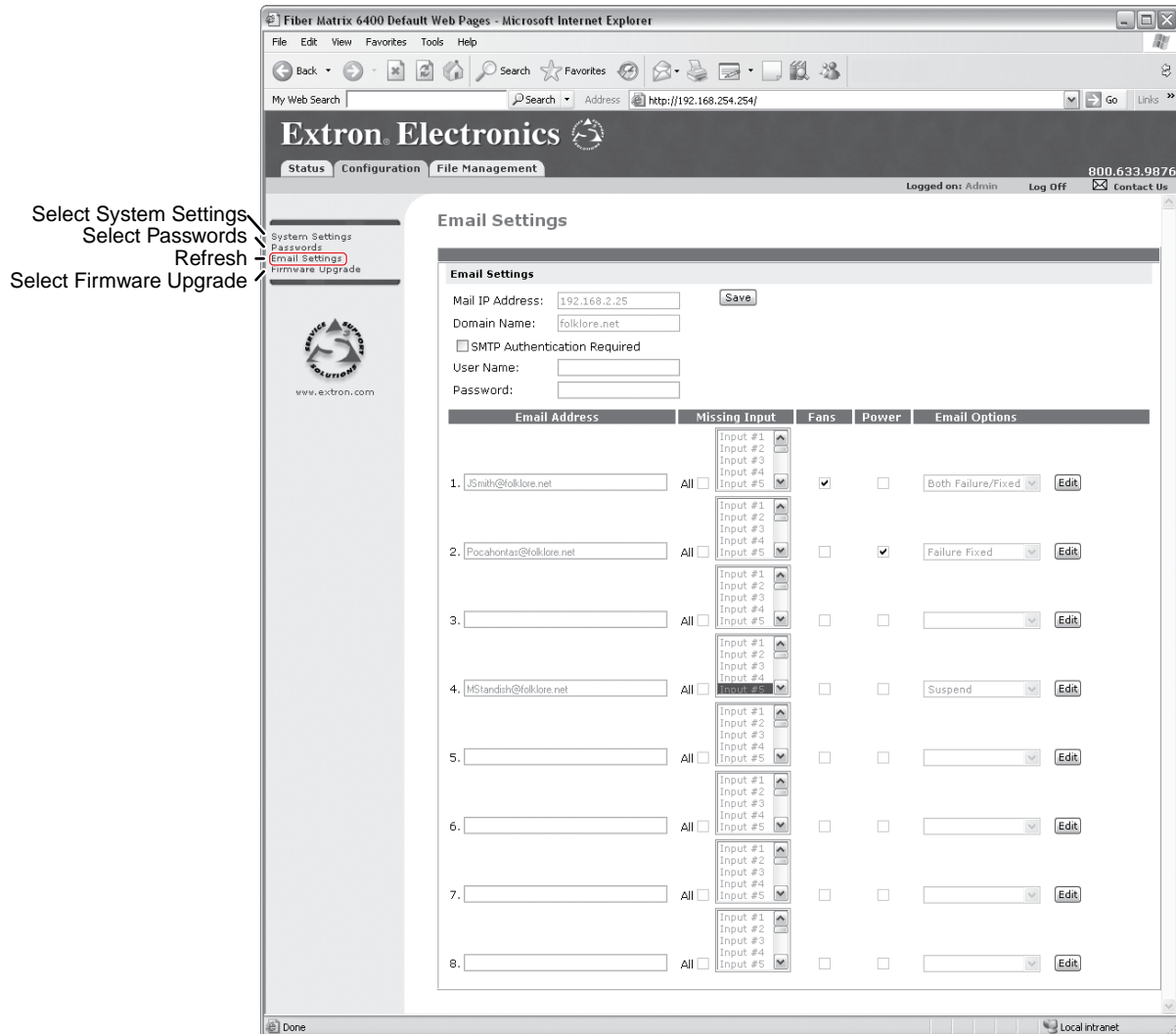

Figure 6-7 — Email Settings page

Mail IP Address field

The Mail IP Address field displays the IP address and the domain name of the e-mail server for the facility in which the Fiber Matrix switcher is installed. Standard IP protocol rules apply to the Mail IP address

Domain Name field

The Domain Name field displays the domain name that the Fiber Matrix switcher uses to log on to the e-mail server. Standard domain name conventions (for example: xxx.com) apply.

HTML Operation, cont'd

NOTE The following characters are invalid in a domain name:
{space} @ + ~ , = ' [] { } < > ' " ; : | \ and ?.

Email Address fields

The eight Email Address fields identify the e-mail addresses of the personnel to whom the Fiber Matrix switcher e-mails notification of its failure and repair status. Standard e-mail address conventions (*nnnnn@xxx.com*) apply.

The check boxes and drop boxes associated with each address field permit the operator to specify specific criteria under which the switcher will e-mail recipients. In the associated Missing Input drop boxes, select the inputs to monitor for presence or absence of a signal. Check the Fans and Power boxes to monitor the cooling and power supplies. In the associated Email Options drop box, select whether the recipient is to be e-mailed of failures, fixes, both, not notified, or to be removed from the e-mail list. The Suspend option is useful for temporarily removing personnel from the e-mail list when they are unavailable, such as on travel or vacation. Deleting an e-mail addressee and clicking the **Submit** button removes the recipient from e-mail notification completely.

Firmware Upgrade page

The Firmware Upgrade page provides a way to replace the firmware that is coded on the switcher's control board without taking the switcher out of service, opening the switcher enclosure, and replacing the firmware chip. Access the Firmware Upgrade page (figure 6-8) by clicking the **Firmware Upgrade** link on the System Settings page.

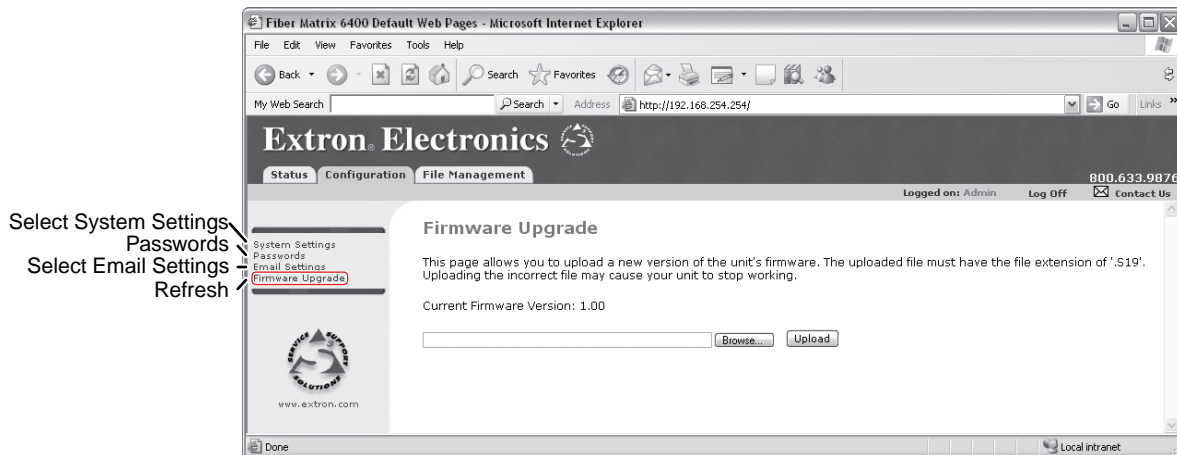

Figure 6-8 — Firmware Upgrade page

Update the switcher firmware as follows:

NOTE The Firmware Upgrade page is **only** for replacing the firmware that controls all switcher operation. To insert your own custom HTML pages, see "File Management Page", on page 6-12.

1. Visit the Extron Web site, www.extron.com, select the Fiber Matrix 6400 product category, select the latest firmware installation package (*.exe file) for the switcher, and download the file. Note the folder to which you save the firmware file.
2. Run the executable (*.exe) file to decompress the firmware file.
3. Connect the PC to the Fiber Matrix switcher via the switcher's LAN port.
4. Access the Fiber Matrix switcher using HTML pages.
5. Click the **Configuration** tab.
6. Click the **Firmware Upgrade** link (figure 6-9).

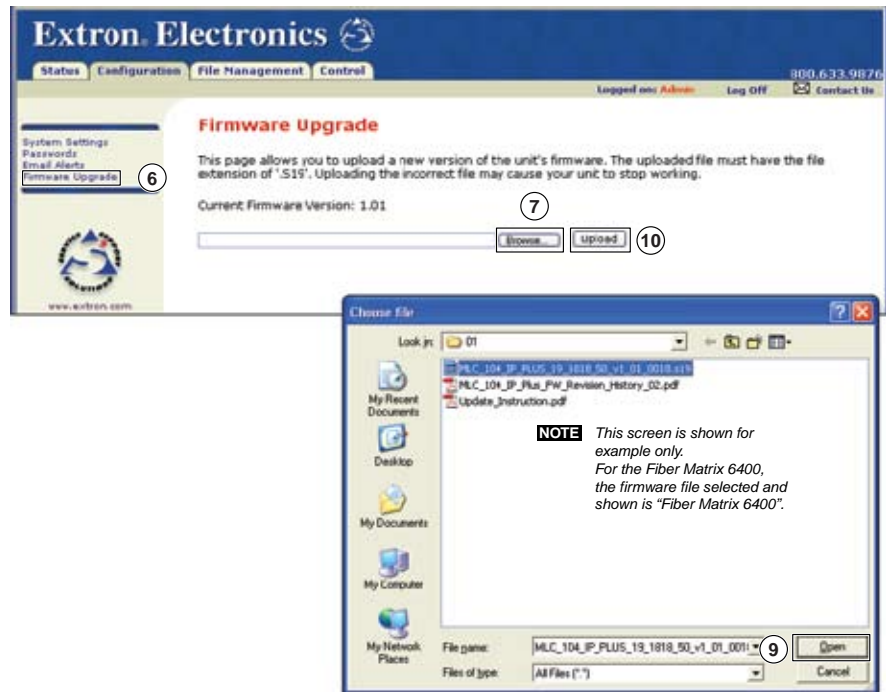

Figure 6-9 — Firmware upgrade

7. Click the **Browse** button. A Choose File window appears.
8. Navigate to the folder where you saved the firmware upgrade file. Select the file.

NOTE Valid firmware files must have the file extension “.S19”. Any other file extension is **not** a firmware upgrade.

NOTE The original factory-installed firmware is permanently available on the Fiber Matrix switcher. If the attempted firmware upload fails for any reason, the switcher automatically reverts to the factory-installed firmware.

9. Click the **Open** button.
10. Click the **Upload** button. The firmware upload to the Fiber Matrix switcher may take a few minutes.

HTML Operation, cont'd

File Management Tab

File Management page

To delete files such as HTML pages from the switcher or to upload your own files to the switcher, click the **File Management** tab. The switcher downloads the File Management HTML page (figure 6-10).

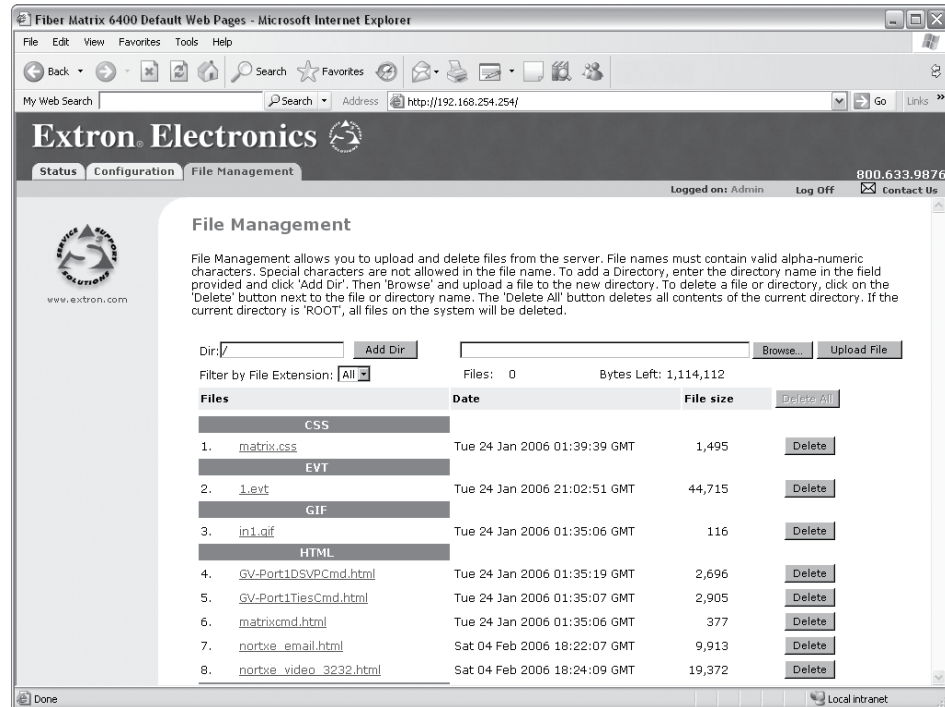

Figure 6-10 — File Management page

NOTE The files listed in figure 6-10 are shown for example only and may not be present on your switcher.

To delete a file, click the **Delete** button associated with a file.

Upload your own files as follows:

NOTE The following characters are invalid in file names:
{space} + ~ , @ = ' [] { } < > ' " ; : | \ and ?.

1. Click the **Browse** button.
2. Browse through your system and select the desired file(s).

NOTE If you want one of the pages that you create and upload to be the default startup page, name that file "index.html".

3. Click the **Upload File** button. The file(s) that you selected appear(s) in the list.

Special Characters

The HTML language reserves certain characters for specific functions. The switcher does not accept these characters as part of preset names, the switcher's name, passwords, or locally created file names.

The switcher rejects the following characters:

{space} + ~ , @ = ' [] { } < > ' " semicolon (;) colon (:)| \ and ?.



Fiber Matrix 6400 Switcher

Chapter Seven

Maintenance and Modifications

Removing and Installing the I/O Board or Blank Panel

Removing and Installing the Power Supply Module

Removing and Installing Button Labels

Maintenance and Modifications

Removing and Installing the I/O Board or Blank Panel

WARNING The Fiber Matrix 6400 fiber optic I/O boards output continuous invisible light, which may be harmful and dangerous to the eyes; use with caution.

- Do not look into the rear panel fiber optic cable connectors or into the fiber optic cables themselves.
- Plug the attached dust caps into the optical transceivers when the fiber optic cable is unplugged.

NOTE As factory configured, the fiber optic I/O boards are configured as either 100 percent singlemode or 100 percent multimode, but you can remove a fiber optic transceiver module (one input and one output) of one transmission mode and replace it with a block of the other transmission mode.

You can mix transmission mode transceiver modules on a fiber optic I/O board, provided that you ensure that each fiber cable and connected devices are the appropriate transmission mode for the transceiver module.

Typically, singlemode fiber has a yellow jacket and multimode cable has an orange jacket.

NOTE Unlike the FOX 500 transmitters and receivers, which output an optical stream on one connector in a block and receive a return optical stream on the second connector in the same block, the fiber optic I/O board uses one connector on the block as an input and the second connector on the same block as a separate output.

NOTE For proper cooling and air flow, boards and/or blank panels should be installed in all locations during normal switcher operations.

Circuit boards can be replaced for fault correction or to accommodate SDI/HD-SDI (electric) signals. They can be added or removed to increase or decrease the I/O configuration (size) of the Fiber Matrix.

See figure 7-1. Each I/O board is identified by the input and output numbers supported by the board position (1 - 8, 9 - 16, and so on) The transceiver modules on fiber optic I/O boards and the BNC connectors on SDI/HD-SDI boards are identified as A through H.

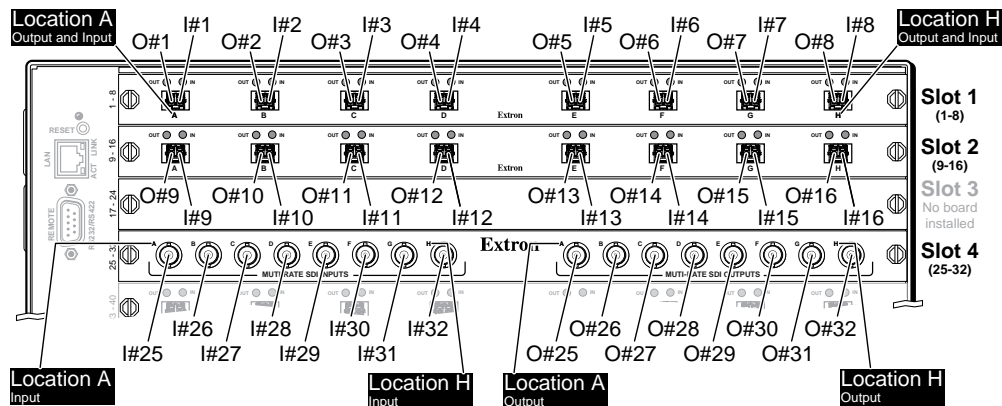

Figure 7-1 — Arrangement of inputs and outputs on the I/O boards

Locations A through H correspond to the output and input numbers identified by the board position numbers. (For example, the output and input numbers supported by the I/O board in location 9 - 16 are as follows: A = 9, B = 10, C = 11, D = 12, E = 13, F = 14, G = 15, and H = 16.)

On the fiber optic I/O boards, locations A through H correspond to the transceiver modules, each of which includes an input and an output. Therefore, locations A through H are numbered from left to right.

On the SDI/HD-SDI I/O boards, inputs and outputs are grouped separately, with inputs A through H on the left and outputs A through H on the right.

Removing the I/O board or blank panel

Remove an I/O board or blank panel as follows:

NOTE *The I/O boards are hot-swappable. You do not need to power down the switcher to remove an I/O board.*

1. For an I/O board, disconnect any connected cables.
2. Rotate the left and right knurled knobs to completely loosen the captive screws.
3. Gently pull on the knurled knobs/captive screws to loosen the board or panel from the backplane.
4. Slide the board or panel out of the chassis (figure 7-2).

CAUTION *Do not touch the electronic components or the connectors on the backplane or on the circuit boards without being electrically grounded. Handle circuit boards by their edges only. ESD can damage circuits, even if you cannot feel, see, or hear it.*

5. Place the removed board on an anti-static surface or in an anti-static container.

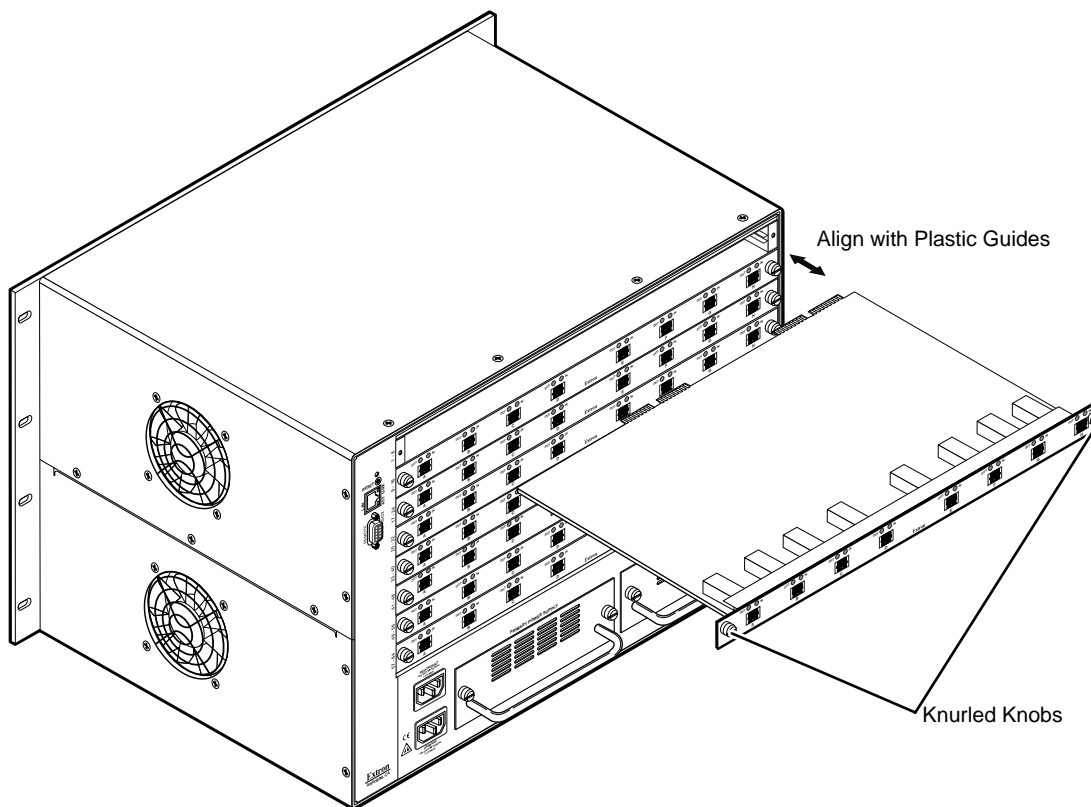

Figure 7-2 — I/O board replacement

Maintenance and Modifications, cont'd

Installing the I/O board or blank panel

NOTE *The I/O boards are hot-swappable. You do not need to power down the switcher to install an I/O board.*

Install an I/O board or blank panel as follows:

CAUTION *Do not touch the electronic components or the connectors on the backplane or on the circuit boards without being electrically grounded. Handle circuit boards by their edges only. ESD can damage circuits, even if you cannot feel, see, or hear it.*

1. **For an I/O board**, orient the board to be installed so that transceiver module A (**fiber board**) or input BNC A (**SDI/HD-SDI board**) is on the left and transceiver module or output BNC H is on the right
2. **For an I/O board**, align the board with the left and right chassis guides (figure 7-2).
3. Gently slide the board or blank panel into the enclosure. **For an I/O board**, slide the board toward the front panel until it meets resistance.
4. Firmly seat the board or panel in the backplane.
5. Tighten the left and right knurled knobs/captive screws to lock the board or panel in place.

NOTE *If necessary, use a screwdriver to tighten the knurled knobs/captive screws.*

Removing and Installing the Power Supply Module

Removing the power supply module

The two power supply modules (primary power supply and redundant power supply) are identical and hot-swappable. Each power supply module has a 2-color LED, visible on the rear panel, that indicates the status of the power supply outputs. If the LED is lit green, the power supply is operating normally. If the LED is lit red, the supply has failed and should be replaced at the earliest opportunity.

NOTE *The power supply modules are hot-swappable. Either power supply can be removed without powering down the switcher.*

Remove a power supply module as follows:

1. Rotate the left and right knurled knobs to completely loosen the captive screws.
2. Gently pull on the handle to loosen the power supply from the backplane (figure 7-3).
3. Slide the power supply out of the chassis.

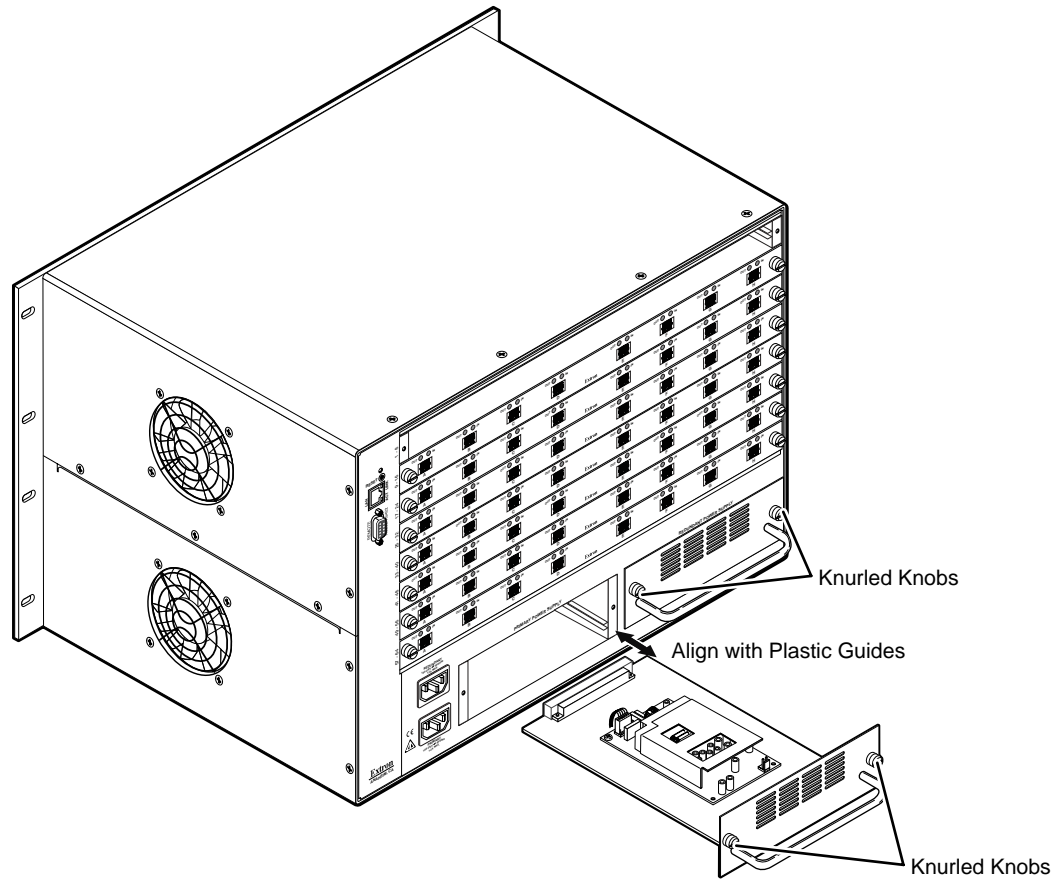

Figure 7-3 — Power supply replacement

Installing the power supply module

NOTE *The power supply modules are hot-swappable. You do not need to power down the switcher to install a power supply.*

Install a power supply module as follows:

1. Orient the power supply module to be installed with the LED to the right.
2. Align the flanges on the power supply module with the left and right power supply guides (figure 7-3).
3. Gently slide the power supply module into the enclosure until the power supply meets resistance.
4. Firmly seat the power supply in the backplane.
5. Tighten the left and right knurled knobs/captive screws to lock the power supply in place.

NOTE *If necessary, use a screwdriver to tighten the knurled knobs/captive screws.*

Maintenance and Modifications, cont'd

Removing and Installing Button Labels

Page 7-7 provides strips of blank button labels. If desired, copy them or cut them out, write button information in each button area as desired, and put them in the switcher's input or output buttons' windows. You can also create labels using the Button-Label Generator software (see chapter 5, "Matrix Software").

Installing labels in the matrix switcher's buttons

Install new labels in the matrix switcher's front panel buttons as follows:

1. Remove the button from the Fiber Matrix; use a small, flat bladed screwdriver such as an Extron Tweeker to gently pry a button out from the front panel (figure 7-4).

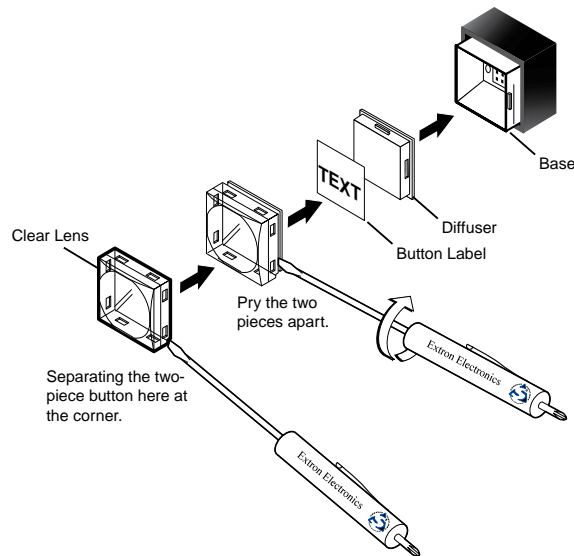
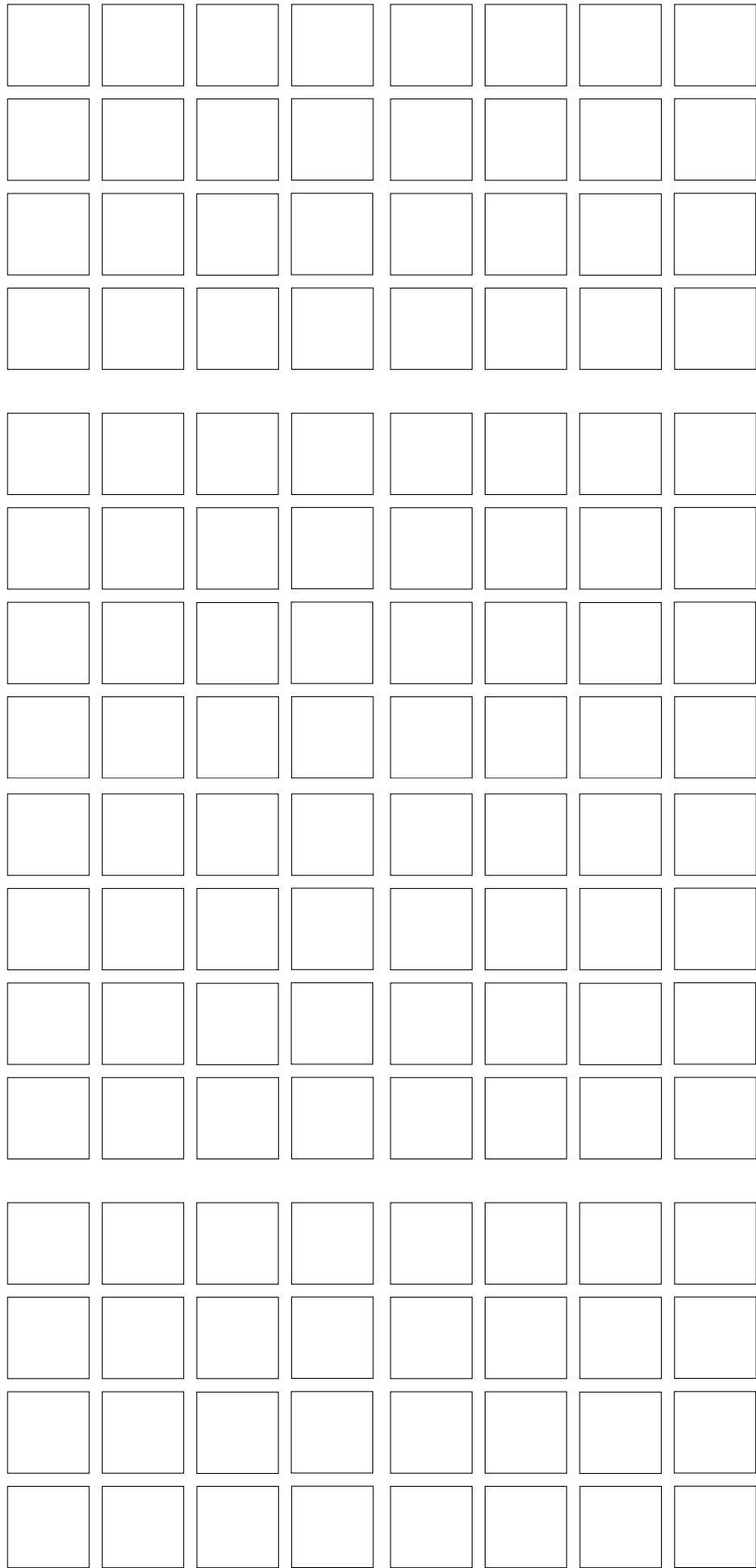

Figure 7-4 — Illuminated button label replacement

2. Locate the notch in the corner of one side of the clear button cap lens.
3. Separate the white backing (diffuser) from the clear button cap (lens); insert the blade of the small screwdriver into the corner notch and gently twist the blade.
4. Save the translucent, white diffuser, but remove the text/label insert from the transparent button cap lens.
5. Insert the replacement button label into the button cap. Check for correct label orientation.
6. Align the white diffuser plate with the cap (lens). The bumps on the diffuser plate should be aligned (top and bottom) with the notches on the clear button cap. Firmly snap it into place.
7. Align the tabs on the Fiber Matrix's base with the notches on the diffuser plate. Gently, but firmly, press the reassembled button into place in the switcher's front panel.
8. Repeat steps 1 to 7 as needed to relabel other buttons.



Button label blanks

Maintenance and Modifications, cont'd



Fiber Matrix 6400 Switcher

Appendix A

Ethernet Connection

Ethernet Link

Subnetting — A Primer

Ethernet Connection

Ethernet Link

The rear panel Ethernet connector on the Fiber Matrix switcher can be connected to an Ethernet LAN or WAN. This connection makes SIS control of the switcher possible using a computer connected to the same LAN.



Ethernet connection

The Ethernet cable can be terminated as a straight-through cable or a crossover cable and must be properly terminated for your application (figure A-1).

- **Crossover cable** — Direct connection between the computer and the Fiber Matrix switcher
- **Patch (straight-through) cable** — Connection of the Fiber Matrix switcher to an Ethernet LAN

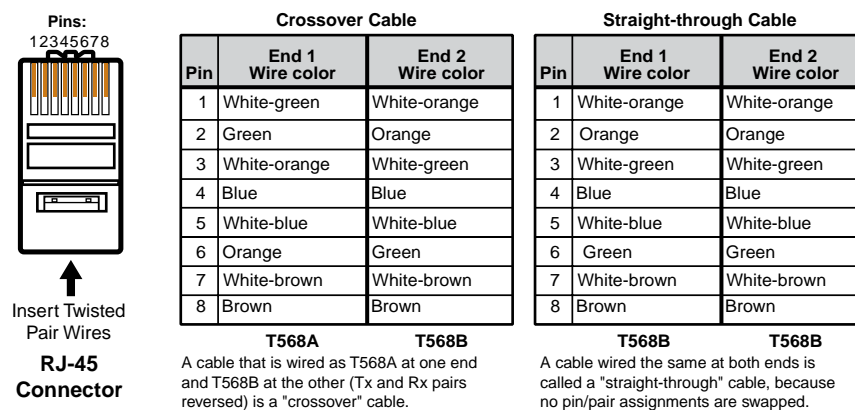

Figure A-1 — RJ-45 connector pinout tables

Default IP address

To access the Fiber Matrix switcher via the LAN port, you need the switcher's IP address. If the address has been changed to an address comprised of words and characters, you can determine the actual numeric IP address using the Ping utility. If the address has not been changed, the factory-specified default is 192.168.254.254.

Ping can also be used to test the Ethernet link to the Fiber Matrix switcher.

Pinging to determine Extron IP address

The Ping utility is available at the DOS prompt. Ping tests the Ethernet interface between the computer and the Fiber Matrix switcher. Ping can also be used to determine the actual numeric IP address from an alias and to determine the web address.

Ping the switcher as follows:

1. On the Windows task bar, click on **Start > Run**.
2. At the Open prompt, type *command*.
3. Click the **OK** button.

-
4. At the DOS prompt, type `ping {IP address}` and then press **Enter**. The computer returns a display similar to as shown below.

The line **Pinging ...** reports the actual numeric IP address, regardless of whether you entered the actual numeric IP address or an alias name.

```
C:\>ping 192.168.254.254

Pinging 192.168.254.254 with 32 bytes of data:

Reply from 192.168.254.254: bytes=32 time<10ms TTL=128
Reply from 192.168.254.254: bytes=32 time<10ms TTL=128
Reply from 192.168.254.254: bytes=32 time<10ms TTL=128
Reply from 192.168.254.254: bytes=32 time<10ms TTL=128

Ping statistics for 192.168.254.254:
    Packets: Sent = 4, Received = 4, Lost = 0 (0% loss),
    Approximate round trip times in milli-seconds:
        Minimum = 0ms, Maximum = 0ms, Average = 0ms
```

Pinging to determine Web IP address

The Ping utility has a modifier, `-a`, that directs the command to return the Web address rather than the numeric IP address.

At the DOS prompt, type `ping -a {IP address}` and then press **Enter**. The computer's return display is similar to the Ping response shown in the figure above, except that when you specify the `-a` modifier, the line **Pinging mail...** reports the web IP address rather than the numeric IP address, regardless of whether you entered the actual numeric IP address or an alias name.

Connecting as a Telnet client

The Microsoft Telnet utility is available from the DOS prompt. Telnet allows you to input SIS commands to the Fiber Matrix switcher from the PC via the Ethernet link and the LAN.

Access the DOS prompt and start Telnet as follows:

1. On the Windows task bar, click on **Start > Run**.
2. At the Open prompt, type `command`.
3. Click the **OK** button.
4. At the DOS prompt, type `telnet` and then press **Enter**. The computer returns a display similar to as shown below.

```
Microsoft (R) windows 2000 (TM) Version 5.0 (Build 2195)
Welcome to Microsoft Telnet Client
Telnet Client Build 5.00.99203.1

Escape Character is 'CTRL+]'

Microsoft Telnet>
```

Ethernet Connection, cont'd

Telnet tips

It is not the intention of this manual to detail all of the operations and functionality of Telnet; however, some basic level of understanding is necessary for operating the Fiber Matrix switcher via Telnet.

Open

Connect to the Fiber Matrix switcher using the Open command. Once you are connected to the switcher, you can enter the SIS commands the same as you would if you were using the RS-232 link.

Connect to the Fiber Matrix switcher as follows:

1. At the Telnet prompt, type `open {IP address}` and then press **[Enter]**.

If the switcher is not password protected, no further prompts are displayed until you break or disconnect the connection to the Fiber Matrix.

If the switcher is password protected, Telnet displays the password prompt.

2. If necessary, at the password prompt, type `{password}` and then press **[Enter]**.

Connection to the switcher via the Ethernet can be password protected. There are two levels of password protection: administrator and user. A person logged on as an administrator has full access to all Fiber Matrix switching capabilities and editing functions. Users can create ties, set mutes, and view all settings with the exception of passwords. By default, the Fiber Matrix switcher ships with both passwords set to {carriage return}.

Once you are logged in, the switcher returns either **Login Administrator** or **Login User**. No further prompts are displayed until you break or disconnect the connection to the Fiber Matrix switcher.

Escape character and Esc key

When Telnet is first started, the utility advises that the **Escape character is 'Ctrl+]**'. Many SIS commands include the keyboard **[Esc]** key. Consequently, some confusion may exist between the Escape character and the Escape key.

The Telnet Escape character is a key combination, the **[Ctrl]** key and the **[J]** key pressed simultaneously, that returns you to the Telnet prompt while leaving the connection to the Fiber Matrix switcher intact.

The Escape key is the **[Esc]** key on the computer keyboard.

Local echo

Once connected to the Fiber Matrix switcher, by default, Telnet does not display your keystrokes on the screen. SIS commands are typed in blindly and only the SIS responses are displayed on the screen. To command Telnet to show keystrokes, at the Telnet prompt, type `set local_echo` and then press **[Enter]** before you open the connection to the switcher.

With local echo turned on, keystrokes and the switcher's responses are displayed on the same line. For example: **1*1!In1 Out1 All**, where **1*1!** is the SIS command and **In1 Out1 All** is the response.

With local echo turned on, all keystrokes are displayed, even those that should be masked, such as the password entry. For example, when entering a password with local echo turned on, you see a display such as **a*d*m*i*n***, where **admin** is the key entered in password and ********* is the masked response.

You can turn off local echo by typing `unset local_echo` and then pressing **[Enter]** at the Telnet prompt. If you are connected to the Fiber Matrix switcher and need to access the Telnet prompt to turn local echo off, type the Escape character (**[Ctrl]+[J]**).

Set carriage return-line feed

Unless commanded otherwise, Telnet transmits a line feed character only (no carriage return) to the connected switcher when you press the **[Enter]** key. This is the correct setting for SIS communication with the switcher. The Telnet `set crlf` command forces Telnet to transmit carriage return and line feed characters when **[Enter]** is pressed, but if `crlf` is set, the SIS link with the switcher does not function properly.

Close

To close the link to the switcher, access the Telnet prompt by typing the Escape character (**Ctrl+I**). At the Telnet prompt, type `close`, and then press **[Enter]**.

Help

For Telnet command definitions, at the Telnet prompt, type `?` and then press **[Enter]**.

Quit

Exit the Telnet utility by typing `quit` and then pressing **[Enter]** at the Telnet prompt. If you are connected to the Fiber Matrix switcher, access the Telnet prompt by typing the Escape character (**Ctrl+I**).

Ethernet Connection, cont'd

Subnetting — A Primer

It is not the purpose of this manual to describe TCP/IP protocol in detail. However, some understanding of TCP/IP subnetting (a subnet is a **subset** of a **network** — a set of IP devices that have portions of their IP addresses in common) is necessary in order to understand the interaction of the Fiber Matrix switcher and the mail server gateway. To understand subnetting at the level required to install and operate the Fiber Matrix switcher, you must understand the concepts of a gateway, local and remote devices, IP addresses and octets, and subnet masks and octets.

Gateways

The Fiber Matrix switcher can communicate with the e-mail server that the switcher uses for e-mail notification directly (if they are on the same subnet) or the communication can be routed via a gateway (a computer that provides a link between different subnets).

Local and remote devices

The local and remote devices are defined from the point of view of the function being described. In this manual, subnetting is an issue when you are using the controlling PC to set TCP/IP and e-mail values in the Fiber Matrix (see “IP Settings/Options window” in chapter 5, “Matrix Software”, and “Email Settings page” in chapter 6, “HTML Operation”). When you are setting up the variables for e-mail notification, which may include subnetting, the matrix switcher is the local device and the e-mail server is the remote device.

IP addresses and octets

Valid IP addresses consist of four 1-, 2-, or 3-digit numeric subfields, properly called octets, separated by dots (periods) as shown below. Each octet can be numbered from 000 through 255. Leading zeroes, up to three digits total per octet, are optional. Values of 256 and above are invalid.

Typical IP Address: 192,168,254,254
Octets

Subnet masks and octets

The subnet mask (shown below) is used to determine whether the local and remote devices are on the same subnet or different subnets. The subnet mask consists of four numeric octets separated by dots. Each octet can be numbered from 000 through 255. Leading zeroes, up to three digits total per octet, are optional. Each octet typically contains either 255 or 0. The octets determine whether or not the same octets of two IP addresses will be compared when determining if two devices are on the same subnet.

255 indicates that this octet will be compared between two IP addresses. 0 indicates that this octet will **not** be compared between two IP addresses.

Typical Subnet Mask: 255,255,0,0
Octets

Determining whether devices are on the same subnet

To determine the subnet, the local device's IP address is **compared** to the remote device's IP address (below). Each address's octets are **compared** or **not compared**, depending on the value in the related subnet mask octet.

- If a subnet mask octet contains the value 255, the related octets of the local device's address and the remote device's IP address are unmasked.

Unmasked octets are compared (indicated by ? in the figure below).

- If the subnet mask octet contains the value 0, the related octets of the local device's and remote device's IP addresses are masked.

Masked octets are not compared (indicated by X in the figure below).

If the unmasked octets of the two IP addresses **match** (indicated by = in the figure below) (example 1), the two addresses **are on the same subnet**.

If the two unmasked fields **do not match** (indicated by ≠ in the figure below) (example 2 and example 3), the addresses **are not on the same subnet**.

	Example 1	Example 2	Example 3
Local IP Address:	192.168.254.254	192.168.254.254	192.168.254.254
Subnet Mask:	255.255.0.0 (??.X.X)	255.255.0.0 (?.?.X.X)	255.255.0.0 (?.?.X.X)
Remote IP Address:	192.168.2.25	190.190.2.25	192.190.2.25
Match?:	<u>==.X.X — Match</u> (Same subnet)	<u>≠.X.X — No match</u> (Different subnet)	<u>≠.X.X — No match</u> (Different subnet)

Ethernet Connection, cont'd



Fiber Matrix 6400 Switcher

Appendix B

Specifications, Part Numbers, Accessories

Specifications

Part Numbers and Accessories

Specifications, Part Numbers, Accessories

Specifications

NOTE *The Fiber Matrix 6400 I/O boards are class 1 laser products. They meet the safety regulations of IEC-60825, FDA 21, CFR 1040.10, and FDA 21 CFR 1040.11.*

Optical specifications

Number/type 8 single mode or 8 multimode fiber optic inputs and outputs per I/O card

NOTE *Only one fiber is required to transmit video, audio, and unidirectional data. A second fiber is required to transmit return data for bidirectional control/communication.*

Connectors 8 LC connectors per I/O card

Operating distance

Singlemode..... 30 km (18.75 miles) with singlemode (SM) cables with an Extron singlemode Tx/Rx unit

Multimode..... 300 m (985') with 62.5 μ m multimode (MM) cables with an Extron multimode Tx/Rx unit
1 km (3280') with 50 μ m multimode (MM) cables with an Extron multimode Tx/Rx unit
2 km (6561') with 50 μ m 2000 MHz bandwidth laser optimized multimode cable with an Extron multimode Tx/Rx unit

NOTE *Operating distance is approximate. These are typical maximum distances that may vary depending on factors such as fiber type, fiber bandwidth, connector splicing, losses, modal or chromatic dispersion, environmental factors, and kinks*

Nominal peak wavelength..... 850 nm for multimode (MM), 1310 nm for single mode (SM)

Transmission power

Singlemode..... -5 dBm, typical

Multimode..... -5 dBm, typical

Maximum receiver sensitivity

Singlemode..... -18 dBm, typical

Multimode..... -12 dBm, typical

Optical loss budget

Singlemode..... 13 dB, maximum

Multimode..... 7 dB, maximum

Maximum channel data rate..... 4.25 Gbps

Video

Routing 8 x 8 up to 64 x 64 unidirectional (Tx) matrix or
4 x 4 up to 32 x 32 bidirectional (Tx/Rx) matrix

Gain Unity

Pixel data bit depth 8 bits per channel, 3 channels (R, G, B)

Maximum resolution 1600x1200 @ 60 Hz, digitized pixel for pixel; higher resolutions up to 2048x1120, undersampled

Video/audio input

Number/signal type..... 8 to 64 fiber optic signals

Connectors 8 LC connectors per I/O card

NOTE *Input comes from an Extron FOX 500 Tx transmitter, FOX 500 DA6, or FOX 500 DVI transmitter.*

Video/audio output

Number/signal type.....	8 to 64 fiber optic signals
Connectors	8 LC connectors per I/O card

NOTE Output connects to an Extron FOX 500 Rx receiver or FOX 500 DVI receiver.

Digital video — 3G HD-SDI I/O board (multi-rate SDI)

Routing	8 x 8 matrix per I/O card, up to 64 x 64
Gain.....	Unity
Maximum data rate.....	2.97 Gbps
Data types.....	8 or 10 bit
Operation standards	SMPTE 292M, SMPTE 259M, SMPTE 424M, ITU-RBT.601, ITU-RBT.1120

Digital video input — 3G HD-SDI I/O board (multi-rate SDI)

Number/signal type.....	8 single link SDI, HD-SDI, or 3 Gbps HD-SDI
Connectors	8 female BNC
Nominal level	0.80 V _{p-p} ±10%
Impedance.....	75 ohms
Return loss.....	<-15 dB @ 1 MHz to 1.5 GHz
Equalization	Automatic
Input cable equalization distance	

HD-SDI

Extron SHR, Belden 1694A cable	492' (150 m)
Extron HR, Belden 1505A cable	328' (100 m)

SDI

Extron SHR, Belden 1694A cable	984' (300 m)
Extron HR, Belden 1505A cable	656' (200 m)

NOTE The transmission distance varies depending on the signal resolution and on the type of cable, graphic card, and display used in the system.

Digital video output — 3G HD-SDI I/O board (multi-rate SDI)

Number/signal type.....	8 single link SDI, HD-SDI, or 3Gbps HD-SDI
Connectors	8 female BNC
Nominal level	0.80 V _{p-p} ±10%
Return loss.....	<-15 dB @ 1 MHz to 1.5 GHz
DC offset.....	±0.5 V with input at 0 offset
Re-clocking.....	Automatic, or use available bypass mode for nonstandard rates
Jitter.....	<0.2 VI
Rise/fall time (20-80%)	
SDI.....	700 ps ±100 ps
HD-SDI	250 ps ±100 ps

Control/remote — switcher

Serial control port.....	1 bidirectional RS-232 or RS-422, 9-pin female D connector (rear panel) 1 bidirectional RS-232, 2.5 mm mini stereo jack (front panel)
Baud rate and protocol.....	9600 to 115200 baud, 9600 baud (default), 8 data bits, 1 stop bit, no parity

Specifications, Part Numbers, Accessories, cont'd

Serial control pin configurations

9-pin female D connector	RS-232: 2 = Tx, 3 = Rx, 5 = GND RS-422: 2 = Tx-, 3 = Rx-, 5 = GND, 7 = Rx+, 8 = Tx+
Mini stereo jack	RS-232: tip = Tx, ring = Rx, sleeve = GND
Ethernet control port	1 RJ-45 female connector
Ethernet data rate	10/100Base-T, half/full duplex with autodetect
Ethernet protocol	ARP, DHCP, ICMP (ping), TCP/IP, UDP, Telnet, HTTP, SMTP
Default settings	Link speed and duplex level = autodetected IP address = 192.168.254.254 Subnet mask = 255.255.0.0 Gateway = 0.0.0.0 DHCP = off
Web server	Up to 200 simultaneous sessions 3 MB nonvolatile user memory
Program control	Extron's control/configuration program for Windows® Extron's Simple Instruction Set (SIS™) Microsoft® Internet Explorer ver. 6 or higher, Telnet

General

Power*	2 (positive-negative), 100 VAC to 240 VAC, 50-60 Hz; internal Enclosure without cards: 35 watts at 115 VAC, 60 Hz Enclosure fully loaded with 8 cards: 115 watts at 115 VAC, 60 Hz Each module card: 10 watts at 115 VAC, 60 Hz *A redundant power supply is standard.
Temperature/humidity	Storage: -40 to +158 °F (-40 to +70 °C) / 10% to 90%, noncondensing Operating: +32 to +122 °F (0 to +50 °C) / 10% to 90%, noncondensing
Cooling	Fan, right to left (as viewed from front panel)
Mounting	Rack mountable
Enclosure type	Metal
Enclosure dimensions	12.25" H x 17.0" W x 12.25" D (7U high, full rack wide) (31.1 cm H x 43.1 cm W x 31.1 cm D) (Depth excludes connectors and front handles. Width excludes rack ears.)
Product weight (fully loaded)	35.8 lbs (16.2 kg)
Shipping weight	43 lbs (20 kg)
DIM weight	
USA/Canada	146 lbs (63 kg)
International	171 lbs (78 kg)
Vibration	ISTA 1A in carton (International Safe Transit Association)
Regulatory compliance	
Safety	CE, CUL, UL
EMI/EMC	CE, C-tick, FCC Class A, ICES, VCCI
MTBF	30,000 hours
Warranty	3 years parts and labor

NOTE All nominal levels are at $\pm 10\%$.

NOTE Specifications are subject to change without notice.

Part Numbers and Accessories

Fiber Matrix switcher part numbers

The Fiber Matrix is custom-built to your requirements. You will need to specify the the number, type, and transmission mode (for fiber optic boards) of I/O boards desired when you order a unit. The following part numbers apply:

Matrix switcher part numbers	Part number
Fiber Matrix frame	60-878-01
Singlemode fiber optic 8x8 I/O board	70-649-02
Multimode fiber optic 8x8 I/O board	70-649-01
3G HD-SDI 8x8 I/O board	70-650-01

Included parts

These items are included in each order for a Fiber Matrix switcher:

Included parts	Part number
IEC power cords (2)	
Rubber feet	
<i>Fiber Matrix Setup Guide</i>	
Extron Software Products disk (Matrix Switchers Control Program and Button-Label Generator)	

Replacement/configuration change parts

The following parts can be ordered to change the size of the matrix or to replace components:

Part	Part number
Singlemode fiber optic 8x8 I/O board	70-649-02
Multimode fiber optic 8x8 I/O board	70-649-01
3G HD-SDI 8x8 I/O board	70-650-01
Blank panel, 1 I/O board space	70-651-01
Blank panel, 2 I/O board space	70-652-01
Power supply module	70-648-01
Button cap and diffuser kit (set of 3 button cap assemblies)	70-352-01

Specifications, Part Numbers, Accessories, cont'd

Optional accessories

These items can be ordered separately:

Adapters, power supplies, labels	Part number
MKP 1000 remote keypad	
Black	60-239-02
White	60-239-03
WT (water-tight) (black)	60-239-52
WT (white)	60-239-53
MCP 1000P (primary)	60-298-01
MCP 1000S (secondary)	60-298-02
MKP 2000 matrix switcher X-Y remote control panel	
Black	60-682-02
White	60-682-03
MKP 3000	
Black	60-708-02
White	60-708-03
MKP 3000 MAAP	
Black	60-709-02
White	60-709-03
MKP 3000 L (lectern mounted)	60-709-22

Extron's Warranty

Extron Electronics warrants this product against defects in materials and workmanship for a period of three years from the date of purchase. In the event of malfunction during the warranty period attributable directly to faulty workmanship and/or materials, Extron Electronics will, at its option, repair or replace said products or components, to whatever extent it shall deem necessary to restore said product to proper operating condition, provided that it is returned within the warranty period, with proof of purchase and description of malfunction to:

**USA, Canada, South America,
and Central America:**

Extron Electronics
1001 East Ball Road
Anaheim, CA 92805
U.S.A.

Japan: Extron Electronics, Japan
Kyodo Building, 16 Ichibancho
Chiyoda-ku, Tokyo 102-0082
Japan

Europe, Africa, and the Middle East:

Extron Europe
Hanzeboulevard 10
3825 PH Amersfoort
The Netherlands

China:

Extron China
686 Ronghua Road, Songjiang
District
Shanghai 201611
China

Asia:

Extron Asia
135 Joo Seng Road, #04-01
PM Industrial Bldg.
Singapore 368363
Singapore

Middle East:

Extron Middle East
Dubai Airport Free Zone
F12, PO Box 293666
United Arab Emirates, Dubai

This Limited Warranty does not apply if the fault has been caused by misuse, improper handling care, electrical or mechanical abuse, abnormal operating conditions or non-Extron authorized modification to the product.

If it has been determined that the product is defective, please call Extron and ask for an Applications Engineer at (714) 491-1500 (USA), 31.33.453.4040 (Europe), 65.383.4400 (Asia), or 81.3.3511.7655 (Japan) to receive an RA# (Return Authorization number). This will begin the repair process as quickly as possible.

Units must be returned insured, with shipping charges prepaid. If not insured, you assume the risk of loss or damage during shipment. Returned units must include the serial number and a description of the problem, as well as the name of the person to contact in case there are any questions.

Extron Electronics makes no further warranties either expressed or implied with respect to the product and its quality, performance, merchantability, or fitness for any particular use. In no event will Extron Electronics be liable for direct, indirect, or consequential damages resulting from any defect in this product even if Extron Electronics has been advised of such damage.

Please note that laws vary from state to state and country to country, and that some provisions of this warranty may not apply to you.

Extron **USA - West**
Headquarters
+800.633.9876
Inside USA / Canada Only
+1.714.491.1500
+1.714.491.1517 FAX

Extron **USA - East**
+800.633.9876
Inside USA / Canada Only
+1.919.863.1794
+1.919.863.1797 FAX

Extron **Europe**
+800.3987.6673
Inside Europe Only
+31.33.453.4040
+31.33.453.4050 FAX

Extron **Asia**
+800.7339.8766
Inside Asia Only
+65.6383.4400
+65.6383.4664 FAX

Extron **Japan**
+81.3.3511.7655
+81.3.3511.7656 FAX

Extron **China**
+400.883.1568
Inside China Only
+86.21.3760.1568
+86.21.3760.1566 FAX

Extron **Middle East**
+971.4.2991800
+971.4.2991880 FAX