

# HD CTL 100

Workspace Controller



# Safety Instructions

## Safety Instructions • English

**⚠ WARNING:** This symbol, , when used on the product, is intended to alert the user of the presence of uninsulated dangerous voltage within the product's enclosure that may present a risk of electric shock.

**ATTENTION:** This symbol, , when used on the product, is intended to alert the user of important operating and maintenance (servicing) instructions in the literature provided with the equipment.

For information on safety guidelines, regulatory compliances, EMI/EMF compatibility, accessibility, and related topics, see the Extron Safety and Regulatory Compliance Guide, part number 68-290-01, on the Extron website, [www.extron.com](http://www.extron.com).

## Sicherheitsanweisungen • Deutsch

**WARUNG:** Dieses Symbol , auf dem Produkt soll den Benutzer darauf aufmerksam machen, dass im Inneren des Gehäuses dieses Produktes gefährliche Spannungen herrschen, die nicht isoliert sind und die einen elektrischen Schlag verursachen können.

**VORSICHT:** Dieses Symbol , auf dem Produkt soll dem Benutzer in der im Lieferumfang enthaltenen Dokumentation besonders wichtige Hinweise zur Bedienung und Wartung (Instandhaltung) geben.

Weitere Informationen über die Sicherheitsrichtlinien, Produkthandhabung, EMI/EMF-Kompatibilität, Zugänglichkeit und verwandte Themen finden Sie in den Extron-Richtlinien für Sicherheit und Handhabung (Artikelnummer 68-290-01) auf der Extron-Website, [www.extron.com](http://www.extron.com).

## Instrucciones de seguridad • Español

**ADVERTENCIA:** Este símbolo, , cuando se utiliza en el producto, avisa al usuario de la presencia de voltaje peligroso sin aislar dentro del producto, lo que puede representar un riesgo de descarga eléctrica.

**ATENCIÓN:** Este símbolo, , cuando se utiliza en el producto, avisa al usuario de la presencia de importantes instrucciones de uso y mantenimiento estas están incluidas en la documentación proporcionada con el equipo.

Para obtener información sobre directrices de seguridad, cumplimiento de normativas, compatibilidad electromagnética, accesibilidad y temas relacionados, consulte la Guía de cumplimiento de normativas y seguridad de Extron, referencia 68-290-01, en el sitio Web de Extron, [www.extron.com](http://www.extron.com).

## Instructions de sécurité • Français

**AVERTISSEMENT :** Ce pictogramme, , lorsqu'il est utilisé sur le produit, signale à l'utilisateur la présence à l'intérieur du boîtier du produit d'une tension électrique dangereuse susceptible de provoquer un choc électrique.

**ATTENTION :** Ce pictogramme, , lorsqu'il est utilisé sur le produit, signale à l'utilisateur des instructions d'utilisation ou de maintenance importantes qui se trouvent dans la documentation fournie avec l'équipement.

Pour en savoir plus sur les règles de sécurité, la conformité à la réglementation, la compatibilité EMI/EMF, l'accessibilité, et autres sujets connexes, lisez les informations de sécurité et de conformité Extron, réf. 68-290-01, sur le site Extron, [www.extron.com](http://www.extron.com).

## Istruzioni di sicurezza • Italiano

**AVVERTENZA:** Il simbolo, , se usato sul prodotto, serve ad avvertire l'utente della presenza di tensione non isolata pericolosa all'interno del contenitore del prodotto che può costituire un rischio di scosse elettriche.

**ATTENZIONE:** Il simbolo, , se usato sul prodotto, serve ad avvertire l'utente della presenza di importanti istruzioni di funzionamento e manutenzione nella documentazione fornita con l'apparecchio.

Per informazioni su parametri di sicurezza, conformità alle normative, compatibilità EMI/EMF, accessibilità e argomenti simili, fare riferimento alla Guida alla conformità normativa e di sicurezza di Extron, cod. articolo 68-290-01, sul sito web di Extron, [www.extron.com](http://www.extron.com).

## Instrukcje bezpieczeństwa • Polska

**OSTRZEŻENIE:** Ten symbol, , gdy używany na produkt, ma na celu poinformować użytkownika o obecności izolowanego i niebezpiecznego napięcia wewnątrz obudowy produktu, który może stanowić zagrożenie porażenia prądem elektrycznym.

**UWAGI:** Ten symbol, , gdy używany na produkt, jest przeznaczony do ostrzegania użytkownika ważne operacyjne oraz instrukcje konserwacji (obsługi) w literaturze, wyposażone w sprzęt.

Informacji na temat wytycznych w sprawie bezpieczeństwa, regulacji wzajemnej zgodności, zgodność EMI/EMF, dostępności i Tematy pokrewne, zobacz Extron bezpieczeństwa i regulacyjnego zgodności przewodnik, część numer 68-290-01, na stronie internetowej Extron, [www.extron.com](http://www.extron.com).

## Инструкция по технике безопасности • Русский

**ПРЕДУПРЕЖДЕНИЕ:** Данный символ, , если указан на продукте, предупреждает пользователя о наличии неизолированного опасного напряжения внутри корпуса продукта, которое может привести к поражению электрическим током.

**ВНИМАНИЕ:** Данный символ, , если указан на продукте, предупреждает пользователя о наличии важных инструкций по эксплуатации и обслуживанию в руководстве, прилагаемом к данному оборудованию.

Для получения информации о правилах техники безопасности, соблюдении нормативных требований, электромагнитной совместимости (ЭМП/ЭДС), возможности доступа и других вопросах см. руководство по безопасности и соблюдению нормативных требований Extron на сайте Extron: , [www.extron.com](http://www.extron.com), номер по каталогу - 68-290-01.

## 安全说明 • 简体中文

**警告:**  产品上的这个标志意在警告用户, 该产品机壳内有暴露的危险电压, 有触电危险。

**注意:**  产品上的这个标志意在提示用户, 设备随附的用户手册中有重要的操作和维护(维修)说明。

关于我们产品的安全指南、遵循的规范、EMI/EMF 的兼容性、无障碍使用的特性等相关内容, 敬请访问 Extron 网站, [www.extron.com](http://www.extron.com), 参见 Extron 安全规范指南, 产品编号 68-290-01。

## 安全記事・繁體中文

**警告:** ⚠ 若產品上使用此符號, 是為了提醒使用者, 產品機殼內存在未隔離的危險電壓, 可能會導致觸電之風險。

**注意:** ⚠ 若產品上使用此符號, 是為了提醒使用者, 設備隨附的用戶手冊中有重要的操作和維護(維修)說明。

有關安全性指導方針、法規遵守、EMI/EMF 相容性、存取範圍和相關主題的詳細資訊, 請瀏覽 Extron 網站: [www.extron.com](http://www.extron.com), 然後參閱《Extron 安全性與法規遵守手冊》, 準則編號 68-290-01。

## 安全上のご注意・日本語

**警告:** この記号 ⚠ が製品上に表示されている場合は、筐体内に絶縁されていない高電圧が流れ、感電の危険があることを示しています。

**注意:** この記号 ⚠ が製品上に表示されている場合は、本機の取扱説明書に記載されている重要な操作と保守(整備)の指示についてユーザーの注意を喚起するものです。

安全上のご注意、法規遵守、EMI/EMF適合性、その他の関連項目については、エクストロンのウェブサイト [www.extron.com](http://www.extron.com) より「Extron Safety and Regulatory Compliance Guide」(P/N 68-290-01) をご覧ください。

## 안전 지침・한국어

**경고:** 이 기호 ⚠ 가 제품에 사용될 경우, 제품의 인클로저 내에 있는 접지되지 않은 위험한 전류로 인해 사용자가 감전될 위험이 있음을 경고합니다.

**주의:** 이 기호 ⚠ 가 제품에 사용될 경우, 장비와 함께 제공된 책자에 나와 있는 주요 운영 및 유지보수(정비) 지침을 경고합니다.

안전 가이드라인, 규제 준수, EMI/EMF 호환성, 접근성, 그리고 관련 항목에 대한 자세한 내용은 Extron 웹 사이트([www.extron.com](http://www.extron.com))의 Extron 안전 및 규제 준수 안내서, 68-290-01 조항을 참조하십시오.

## Copyright

© 2018-2020 Extron Electronics. All rights reserved. [www.extron.com](http://www.extron.com)

## Trademarks

All trademarks mentioned in this guide are the properties of their respective owners.

The following registered trademarks (®), registered service marks (SM), and trademarks (TM) are the property of RGB Systems, Inc. or Extron Electronics (see the current list of trademarks on the [Terms of Use](#) page at [www.extron.com](http://www.extron.com)):

Registered Trademarks (®)
Extron, Cable Cubby, ControlScript, CrossPoint, DTP, eBUS, EDID Manager, EDID Minder, Flat Field, FlexOS, Glitch Free, Global Configurator, Global Scriber, GlobalViewer, Hideaway, HyperLane, IP Intercom, IP Link, Key Minder, LinkLicense, LockIt, MediaLink, MediaPort, NAV, NetPA, PlenumVault, PoleVault, PowerCage, PURE3, Quantum, ShareLink, Show Me, SoundField, SpeedMount, SpeedSwitch, StudioStation, System <i>INTEGRATOR</i> , TeamWork, TouchLink, V-Lock, VideoLounge, VN-Matrix, VoiceLift, WallVault, WindoWall, XPA, XTP, XTP Systems, and ZipClip
Registered Service Mark (SM): S3 Service Support Solutions
Trademarks (TM)
AAP, AFL (Accu-RATE Frame Lock), ADSP (Advanced Digital Sync Processing), Auto-Image, AVEdge, CableCover, CDRS (Class D Ripple Suppression), Codec Connect, DDSP (Digital Display Sync Processing), DMI (Dynamic Motion Interpolation), Driver Configurator, DSP Configurator, DSVP (Digital Sync Validation Processing), eLink, EQIP, Everlast, FastBite, Flex55, FOX, FOXBOX, IP Intercom HelpDesk, MAAp, MicroDigital, Opti-Torque, PendantConnect, ProDSP, QS-FPC (QuickSwitch Front Panel Controller), Room Agent, Scope-Trigger, SIS, Simple Instruction Set, Skew-Free, SpeedNav, Triple-Action Switching, True4K, True8K, Vector™ 4K, WebShare, XTRA, and ZipCaddy

## FCC Class A Notice

This equipment has been tested and found to comply with the limits for a Class A digital device, pursuant to part 15 of the FCC rules. The Class A limits provide reasonable protection against harmful interference when the equipment is operated in a commercial environment. This equipment generates, uses, and can radiate radio frequency energy and, if not installed and used in accordance with the instruction manual, may cause harmful interference to radio communications. Operation of this equipment in a residential area is likely to cause interference. This interference must be corrected at the expense of the user.

**NOTE:** For more information on safety guidelines, regulatory compliances, EMI/EMF compatibility, accessibility, and related topics, see the “[Extron Safety and Regulatory Compliance Guide](#)” on the Extron website.

## VCCI-A Notice

この装置は、クラスA 情報技術装置です。この装置を家庭環境で使用すると、電波妨害を引き起こすことがあります。その場合には使用者が適切な対策を講ずるよう要求されることがあります。

VCCI-A

## Battery Notice

This product contains a battery. **Do not open the unit to replace the battery.** If the battery needs replacing, return the entire unit to Extron (for the correct address, see the Extron Warranty section on the last page of this guide).

**CAUTION:** Risk of explosion. Do not replace the battery with an incorrect type. Dispose of used batteries according to the instructions.

**ATTENTION :** Risque d’explosion. Ne pas remplacer la pile par le mauvais type de pile. Débarrassez-vous des piles usagées selon le mode d’emploi.

## Conventions Used in this Guide

### Notifications

The following notifications are used in this guide:

 **WARNING:** Potential risk of severe injury or death.

**AVERTISSEMENT :** Risque potentiel de blessure grave ou de mort.

**CAUTION:** Risk of minor personal injury.

**ATTENTION :** Risque de blessure mineure.

**ATTENTION:**

- Risk of property damage.
- Risque de dommages matériels.

**NOTE:** A note draws attention to important information.

**TIP:** A tip provides a suggestion to make working with the application easier.

### Software Commands

Commands are written in the fonts shown here:

```
^AR Merge Scene, ,Op1 scene 1,1 ^B 51 ^W^C
```

```
[01] R 0004 00300 00400 00800 00600 [02] 35 [17] [03]
```

```
[Esc][X1]*[X17]*[X20]*[X23]*[X21]CE←
```

**NOTE:** For commands and examples of computer or device responses mentioned in this guide, the character “0” is used for the number zero and “O” is the capital letter “O.”

Computer responses and directory paths that do not have variables are written in the font shown here:

```
Reply from 208.132.180.48: bytes=32 times=2ms TTL=32
```

```
C:\Program Files\Extron
```

Variables are written in slanted form as shown here:

```
ping xxx.xxx.xxx.xxx -t
```

```
SOH R Data STX Command ETB ETX
```

Selectable items, such as menu names, menu options, buttons, tabs, and field names are written in the font shown here:

```
From the File menu, select New.
```

```
Click the OK button.
```

## Specifications Availability

Product specifications are available on the Extron website, [www.extron.com](http://www.extron.com).

## Extron Glossary of Terms

A glossary of terms is available at <http://www.extron.com/technology/glossary.aspx>.



# Contents

---

## **Introduction ..... 1**

About this Guide.....	1
About the HD CTL 100 Controller .....	1
Features .....	1
HD CTL 100 Configuration Program .....	2
Device Drivers .....	2
Application Diagrams.....	3

---

## **Installation and Operation ..... 4**

Installation Overview .....	4
Rear Panel Features .....	5
Connecting Devices to the Digital I/O Ports.....	8
Installing the LockIt HDMI Cable	
Lacing Brackets.....	9
Connecting Power to the HD CTL 100 .....	10
Front Panel Features.....	12
Resetting .....	13

---

## **Remote Configuration and Control..... 14**

HD CTL 100 Configuration Program .....	14
Downloading and Installing the	
Configuration Program.....	14
Starting the Configuration Program.....	16
Obtaining Device Drivers.....	19
CEC Control .....	25

SIS Commands .....	26
Host-to-Controller Communications .....	26
Controller-initiated Messages.....	26
Error Responses.....	26
Using the Command and Response Table ....	26
Symbol Definitions .....	27
Command and Response Table for SIS	
Commands .....	28

---

## **Application Example ..... 29**

Connection Description .....	30
Configuring the Application	
Using the Software .....	31
Input Signal Detection.....	31
Contact Closure Device .....	33
Occupancy Sensor .....	34
Applying the Configuration.....	36

---

## **Reference Information ..... 37**

Mounting the HD CTL 100.....	37
Tabletop Use .....	37
Rack Mounting .....	37
Wall or Furniture Mounting .....	38



# Introduction

This section gives an overview of the HD CTL 100 Workspace Controller and its features. Topics include:

- [About this Guide](#)
- [About the HD CTL 100 Controller](#)
- [Device Drivers](#)
- [Application Diagrams](#)

## About this Guide

This user guide provides detailed information about cabling and configuring the Extron HD CTL 100 Controller. It also describes the commands that can be used to control these products remotely.

## About the HD CTL 100 Controller

Throughout this guide the general terms “HD CTL 100” and “controller” are used interchangeably to refer to the HD CTL 100 controller.

The Extron HD CTL 100 is a compact workspace controller designed for automatic display control in small meeting rooms and huddle spaces. It features an HDMI pass-through port that detects signal presence and can facilitate automatic display power control. When an active signal is connected to the HDMI input, the HD CTL 100 automatically turns on the display via CEC control. When no signal is detected, the HD CTL 100 powers off the display after a predetermined period. For further flexibility, integration with Extron OCS 100 occupancy sensors can enable the controller to power the display on when users enter the room. Control of the display is provided via one-way RS-232, IR, or Consumer Electronics Control (CEC).

Connecting a ShareLink wireless collaboration gateway adds support for wireless connection of your own devices, providing effective collaboration and content sharing from a variety of mobile devices.

## Features

- **Easy automation for the modern workspace:**
  - Plug and Play
  - No remotes to lose
  - No buttons to press
- **Automatic display control** via unidirectional RS-232, IR, or Consumer Electronics Control (CEC).
- **Supports computer and video resolutions up to 4K/60 @ 4:4:4** — Resolutions up to 4096x2160/60 with 4:4:4 chroma sampling at 8 bits of color.
- **Fully-configurable using HD CTL 100 configuration software**

- **Four configurable digital I/O ports** — Allow for connections with a variety of devices, such as Extron OCS 100 Series Occupancy Sensors, switches, and relays.
- **24 V DC output to power devices** such as occupancy sensors.
- **One HDMI port for the input and one HDMI port for the output.**
- **HDMI with CEC** — Standard, built-in CEC commands can be triggered to control displays or other AV devices connected over HDMI. The ability to control specific functions, such as power on and off, input selection, audio mute toggle on and off, or volume level, is dependent on implementation by the device manufacturer.
- **One configurable IR or serial port for one-way control of external devices.**
- **HDCP 2.3 compatible** — Ensures display of content-protected 4K video media and maintains interoperability with earlier versions of HDCP.
- **Supported HDMI 2.0b specification features include data rates up to 18 Gbps, HDR, Deep Color up to 12 bit, 3D, and HD lossless audio formats.**
- **Support for High Dynamic Range (HDR) video** — Enables greater contrast range and wider color gamut by providing the necessary video bandwidth, color depth, and metadata interchange capability for HDR video.
- **Front panel USB configuration port.**
- **LED indicators for signal presence and power** — Provide visual indication of system status for real-time feedback and monitoring of key performance parameters.
- **1 inch (2.5 cm) high, quarter rack wide metal enclosure** — With a low-profile enclosure, the device can be installed discreetly wherever needed.
- **Includes LockIt® HDMI cable lacing brackets** — Secure HDMI cables to the HDMI connectors.
- **External Extron Everlast™ power supply included** — Provides worldwide power compatibility with high-demonstrated reliability and low power consumption. Extron Everlast Power Supply is covered by a 7-year parts and labor warranty.

## HD CTL 100 Configuration Program

The HD CTL 100 Configuration Program is used to configure the controller ports and set monitors via a USB connection. This program, downloadable from the Extron website, enables you to configure the HD CTL 100 for automatic display control. The program works in combination with the IR or RS-232 device drivers, also available at [www.extron.com](http://www.extron.com) (see [Downloading and Installing the Configuration Program](#) on page 14 to access this program).

## Device Drivers

The HD CTL 100 can control a flat panel TV, projector, or other display device via unidirectional RS-232, IR, or CEC. The controller must have drivers loaded for the devices it controls in order to send commands to those devices.

You can download IR or RS-232 driver files from [www.extron.com](http://www.extron.com) or from Extron via the driver subscription feature within the HD CTL 100 configuration program. By default, the drivers are saved on your computer in a folder located at:

C:\Users\Public\Public Documents\Extron\Driver2

You can upload the desired drivers to the HD CTL 100 using the configuration program.

# Application Diagrams

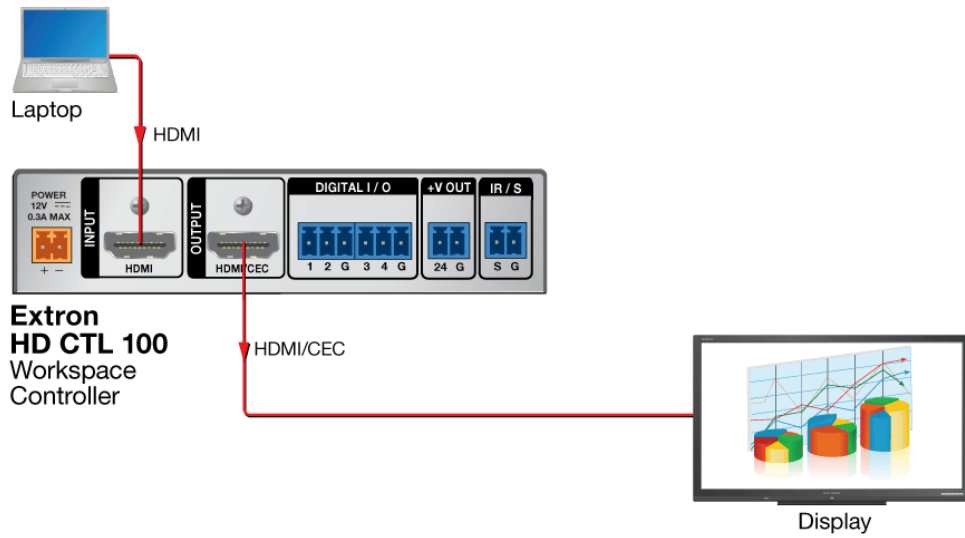

**Figure 1. HD CTL 100 Application Example 1**

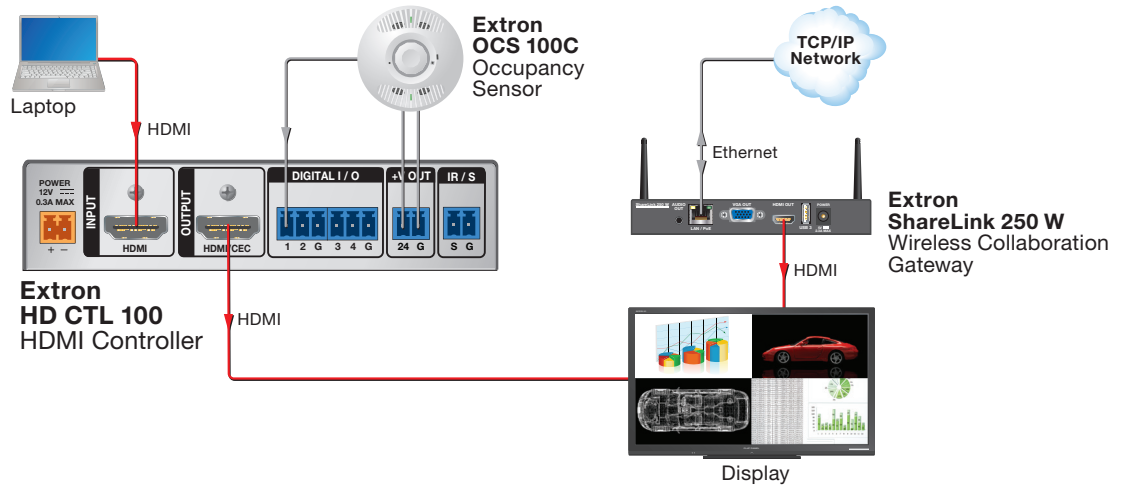

**Figure 2. HD CTL 100 Application Example 2**

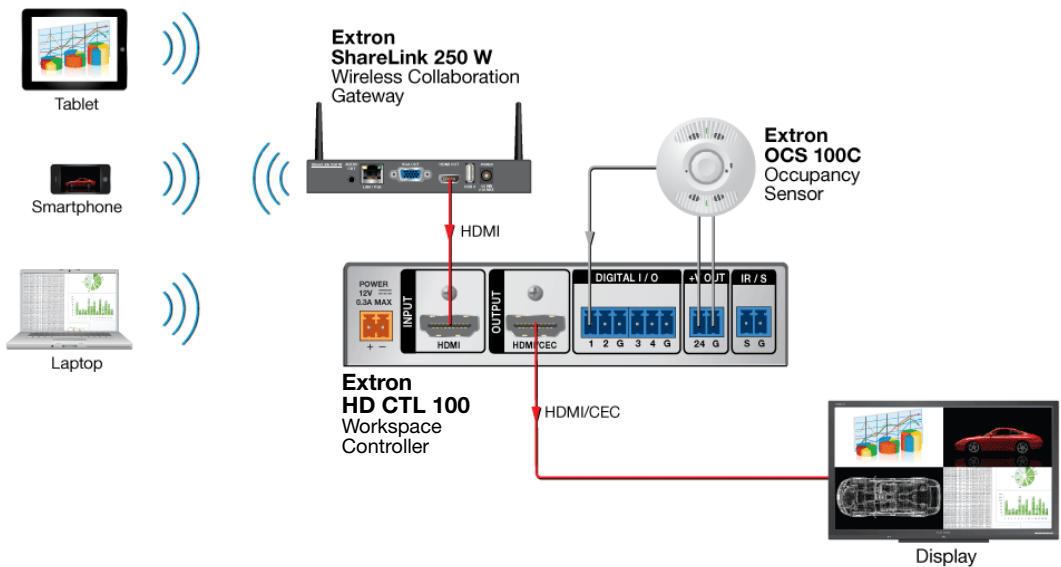

**Figure 3. HD CTL 100 Application Example 3**

# Installation and Operation

This section describes the front and rear panel features of the HD CTL 100, and provides procedures for installing and operating it. Topics include:

- [Installation Overview](#)
- [Rear Panel Features](#)
- [Connecting Power to the HD CTL 100](#)
- [Front Panel Features](#)
- [Resetting](#)

## Installation Overview

### ATTENTION:

- Installation and service must be performed by authorized personnel only.
- L'installation et l'entretien doivent être effectués uniquement par un électricien qualifié.
- All electrical installation should be performed by qualified personnel in accordance with local and national building codes, fire and safety codes, and local and national electrical codes.
- Toute installation électrique devrait être effectuée par un personnel qualifié, conformément aux codes du bâtiment, aux codes incendie et sécurité, et aux codes électriques locaux et nationaux.

1. Mount the HD CTL 100 on a wall, rack, rack shelf, or furniture. Mounting kits and instructions are available at [www.extron.com](http://www.extron.com).

**TIP:** Extron recommends wall-mounting the HD CTL 100 behind the display (place the top panel of the unit against the wall), using a mounting kit such as the Extron MBU 125 Under Desk Mounting Brackets (see [figure 35](#) on page 38).

2. Attach the cables to the rear panel connectors of the HD CTL 100 and to the display device (see [Rear Panel Features](#), beginning on page 5). Attach an optional IR emitter if used.
3. Wire and connect the HD CTL 100 power supply (see [Connecting Power to the HD CTL 100](#) on page 10).
4. Connect all other power cords and power on all the devices, including the HD CTL 100.
5. Download and install the HD CTL 100 Configuration Program (see [Downloading and Installing the Configuration Program](#) on page 14).

6. Download drivers for the devices you are connecting to the HD CTL 100 (see [Obtaining Device Drivers](#) on page 19 or the configuration program help file).
7. Connect a USB A-to-USB mini-B cable to the front panel HD CTL 100 USB CONFIG port and to a USB port on your computer.
8. Configure the HD CTL 100 ports using the configuration program (see the *HD CTL 100 Configuration Program Help* file for these procedures). To access the help file, see [Downloading and Installing the Configuration Program](#) on page 14.

## Rear Panel Features

The HD CTL 100 rear panel contains the following connectors:

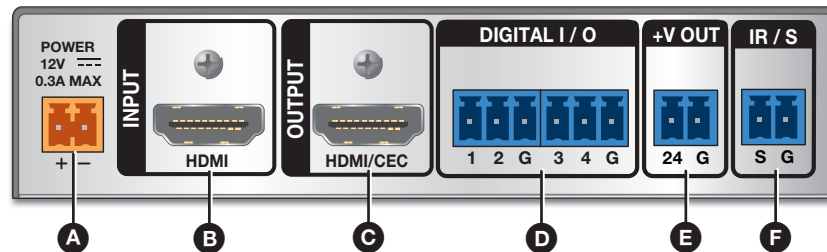

- |                                    |                                   |
|------------------------------------|-----------------------------------|
| <b>A</b> Power connector           | <b>D</b> Digital I/O connector    |
| <b>B</b> HDMI input connector      | <b>E</b> Voltage output connector |
| <b>C</b> HDMI/CEC output connector | <b>F</b> IR/S control connector   |

**Figure 4. HD CTL 100 Rear Panel**

- A Power connector** — Connect the provided 12 VDC, 0.5 A power supply (or any other power supply capable of providing 12 VDC, 0.5 A of power) to this 2-pole captive screw connector.

**ATTENTION:**

- Do not connect power to the unit until you have read the **CAUTION AND ATTENTION notices** on page 10.
- Ne branchez pas l'alimentation au l'unité avant d'avoir lu les mises en garde **ATTENTION** de la page 10.

- B HDMI input connector** — Connect an HDMI source to this female HDMI connector. Resolutions up to 4K (4096 x 2016 @ 60 Hz) are supported. The HD CTL 100 supports an input cable of up to 12 feet (3.6 meters).

**NOTE:** LockIt cable lacing brackets are provided with the HD CTL 100 unit.

These brackets secure the HDMI cables to the rear panel input and output HDMI connectors and reduce stress on the connectors, preventing signal loss due to loose cable connections. To install these brackets, see [Installing the LockIt HDMI Cable Lacing Brackets](#) on page 9.

- C HDMI/CEC output connector** — Connect an HDMI display to this female HDMI pass-through port to enable the controller to turn the display on when HD CTL 100 detects an input signal and off when the signal is no longer detected. The HD CTL 100 supports an output cable of up to 12 feet (3.6 meters).

Through this port, the HD CTL 100 can send pre-loaded CEC commands to the connected HDMI output device (see **CEC Control** on page 24). CEC commands are issued from the HDMI output port and configured using the HD CTL 100 Configuration Program (see **Downloading and Installing the Configuration Program** on page 14 to obtain the configuration software, and the program help file to enable the CEC commands). See figure 5 for an example of wiring the HDMI ports to enable CEC control.

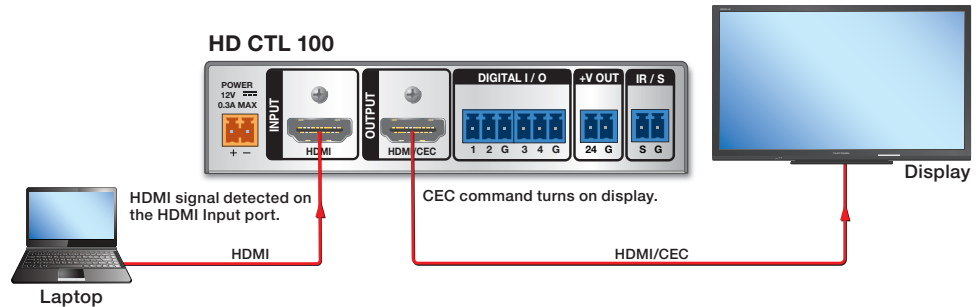
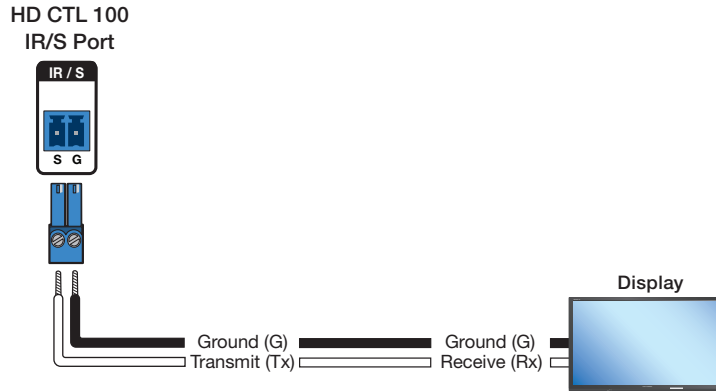

**Figure 5. Wiring for CEC Control**

- D Digital I/O connector** — This 6-pole captive screw connector provides four digital input or output ports (plus two ground pins) to which you can connect sensors, switches, or contact closure buttons. Each port can be configured as a digital input, output, input with pull-up, or output with pull-up, via the HD CTL 100 configuration software. The ports enable you to monitor connected devices and trigger functions on the controller (see **Connecting Devices to the Digital I/O Ports** on page 8 for instructions on wiring devices to these ports).
- E Voltage Output (+V Out) connector** — This +24 V (voltage and ground) captive screw power output can provide power to connected accessories that require +24 V of power, such as occupancy sensors.
- F IR/S control connector** — This port provides unidirectional communication to control a projector or a display via RS-232 or IR. The S (signal) and G (ground) pins of the 2-pole captive screw IR/S connector comprise the IR/serial port.

**NOTE:** The HD CTL 100 can be configured to send CEC, unidirectional RS-232, and IR commands, using the HD CTL 100 Configuration program (see the *HD CTL 100 Configuration Program Help* file for more information).

- **For RS-232 control** — Connect the S and G pins of the IR/S connector to the RS-232 port of a display device or switcher (see figure 6).



**Figure 6. Connecting a Display to the IR/S Port**

- **For IR control** — Connect the S and G pins of the IR/S connector to an IR emitter, with a maximum of 50 feet (15 m) distance from port to emitter. To control devices via infrared (IR) commands from the HD CTL 100, connect an IR emitter to the S (signal) and G (ground) pins of the connector. The IR port provides unidirectional IR signal output to control a display, projector, switcher, or other device such as a Blu-ray player.

**Example:** Figure 7 shows a single IR emitter connected to the IR/S port of an HD CTL 100.

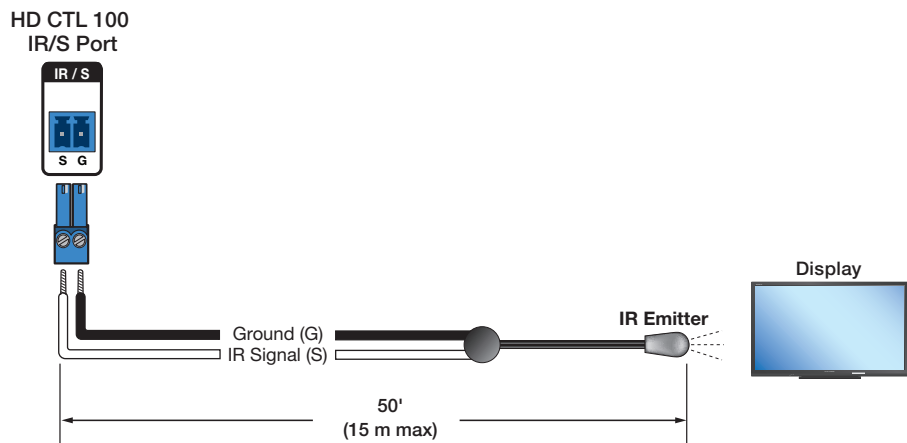

**Figure 7. Connecting a Display to the IR/S Port**

See the communication sheets for your device drivers for information on compatible baud rates and cabling type and distance. These communication sheets are accessed via the HD CTL 100 configuration program and also from the **Download** tab at [www.extron.com](http://www.extron.com) (see **Obtaining Device Drivers** on page 19 or the configuration program help file to view the communication sheets and download the device drivers).

## Connecting Devices to the Digital I/O Ports

The Digital I/O ports on the HD CTL 100 rear panel let you connect a switch or sensor to control other devices in the room that are connected to the HD CTL 100 IR/S control port. The Digital I/O ports measure two states — high and low — of the connection between the switch or sensor and the connected device. The port accepts 0 to 24 VDC input. The threshold voltages are as follows:

- Voltage below 1.0 VDC is measured as logic **low**.
- Voltage above 1.5 VDC is measured as logic **high**.

There is also an internal, +5 VDC, selectable, pull-up resistor for this circuit. If a connected device does not have its own power source and be powered through the controller, select (via the HD CTL 100 configuration software) **Input with Pullup** for this port (see the *HD CTL 100 Configuration Program Help* file to enable input with pullup).

In addition, you can program actions on this port, so that each time a high or low state is detected, one or more functions are performed (see the configuration software help file to configure the Digital I/O ports).

### To wire the Digital I/O connector:

1. Connect a digital input or output device (such as a switch, relay device, or sensor) to pin 1, 2, 3, or 4 and to one of the two G (ground) pins of the Digital I/O connector.

**NOTE:** Use the two 3-pole captive screw plugs provided with the HD CTL 100 to connect devices to the 6-pole Digital I/O connector (no 6-pole plug is provided).

2. (Optional) If using an occupancy sensor or other device that requires +24 V power and does not have a power supply, wire its power connector to the rear panel HD CTL 100 +V OUT connector (see [figure 4, E](#), on page 5, and the illustration at right).

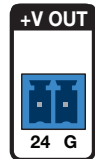

**NOTE:** The maximum current for this connector is 50 mA.

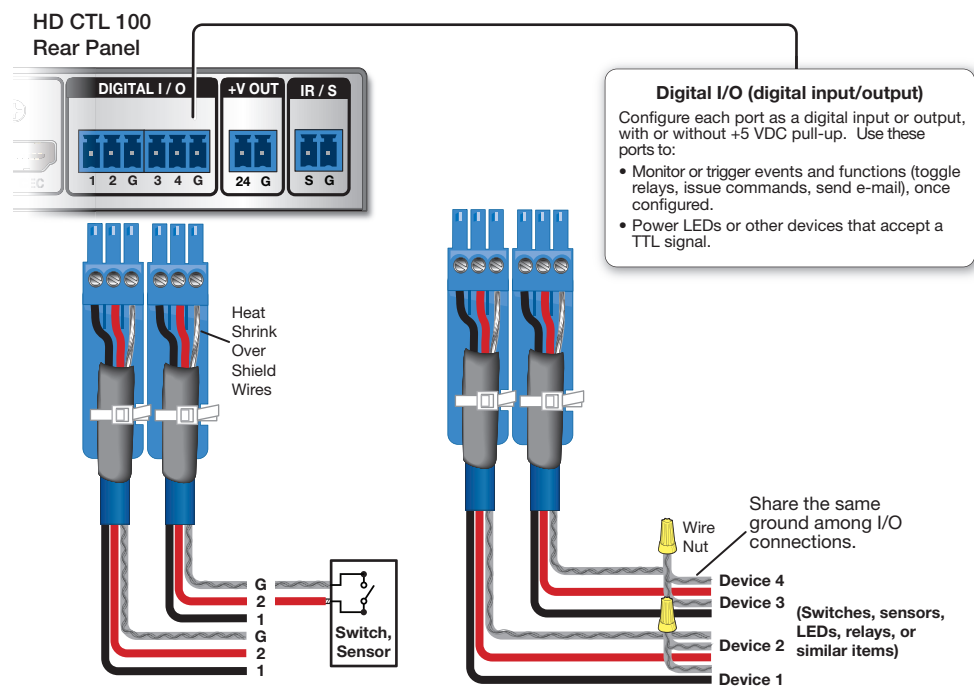

**Figure 8.** Wiring the Digital I/O Connectors (Example)

- **Digital input** — Use one or more of the Digital I/O ports to connect a sensor, such as an occupancy sensor, or a switch, such as a push-button device that can be configured to be triggered by a press or release of the button.
- **Digital output** — Use one or more of the Digital I/O ports as a digital output to control LEDs, incandescent lights, or other devices that accept a transistor-to-transistor logic (TTL) signal. They can also provide contact closure control for projector lifts, motorized screens, or room and light switches when attached to relay devices. Each port can sync up to 250 mA.

**NOTES:**

- If the digital output port is set with pull-up disabled, the voltage output is set by an external source.
- If the pull-up resistor is enabled, the voltage output is equal to approximately +4.6 V.

### Installing the LockIt HDMI Cable Lacing Brackets

The Extron LockIt lacing brackets make it possible to simply and universally secure a standard HDMI cable to most HDMI devices.

**NOTE:** The HDMI device must have an HDMI connection mounting screw for this bracket to be used.

To securely fasten an HDMI cable to a device:

1. Plug the HDMI cable into the panel connection.
2. Loosen the HDMI connection mounting screw from the panel enough to allow the LockIt lacing bracket to be placed over it. The screw does not have to be removed.
3. Place the LockIt lacing bracket on the screw and against the HDMI connector, then tighten the screw to secure the bracket.
4. Loosely place the included tie wrap around the HDMI connector and the LockIt lacing bracket as shown.
5. While holding the connector securely against the lacing bracket, tighten the tie wrap, then remove any excess length.

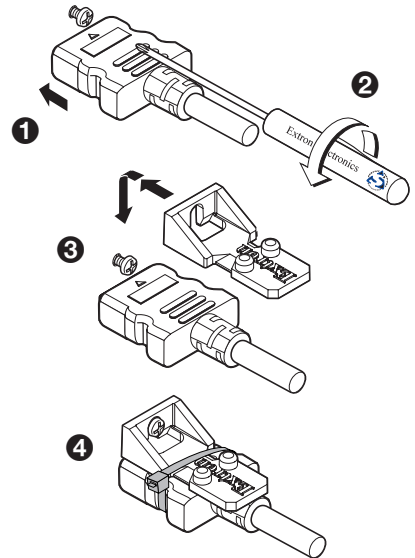

**ATTENTION:**

- Do not overtighten the HDMI connection mounting screw. The shield to which it is fastened is very thin and can easily be stripped.
- Ne serrez pas trop la vis de montage du connecteur HDMI. Le blindage auquel elle est attachée est très fin et peut facilement être dénudé.

## Connecting Power to the HD CTL 100

**CAUTION: Risk of electric shock.** The wires must be kept separate while the power supply is plugged in. Remove power before wiring.

**ATTENTION : Risque de choc électrique.** Les deux cordons d'alimentation doivent être tenus à l'écart l'un de l'autre quand l'alimentation est branchée. Couper l'alimentation avant de faire l'installation électrique.

### ATTENTION:

- The power supply must not be permanently fixed to the building structure or similar structures.
- La source d'alimentation ne devra pas être fixée de façon permanente à une structure de bâtiment ou à une structure similaire.
- Do not place the power supply within environmental air handling spaces or the wall cavity.
- Ne pas placer les sources d'alimentation dans une zone de traitement de l'air ni dans une cavité murale.
- The installation must be in accordance with the applicable provisions of the *National Electrical Code ANSI/NFPA 70, Article 725* and the *Canadian Electrical Code, Part 1, Section 16*.
- Cette installation doit toujours être en accord avec les mesures qui s'applique au *National Electrical Code ANSI/NFPA 70, article 725*, et au *Canadian Electrical Code, partie 1, section 16*.
- Use a UL Listed external power supply with rated output 12 VDC, minimum 0.5 A, NEC Class 2, or LPS output.
- Utilisez une source d'alimentation externe certifiée UL, avec une tension nominale 12 Vcc, 0,5 A minimum, NEC Class 2, ou sortie LPS.
- The power supply must be located within the same vicinity as the Extron AV processing equipment in an ordinary location, Pollution Degree 2, secured to a podium, a desk, or an equipment rack within a dedicated closet.
- La source d'alimentation doit être située à proximité de l'équipement audiovisuel Extron dans un emplacement habituel, avec un degré de pollution 2, fixée à une estrade, un bureau, ou dans une baie technique à l'intérieur d'un placard dédié.
- Always use a power supply specified by Extron for the HD CTL 100. Use of an unauthorized power supply voids all regulatory compliance certification and may cause damage to the supply and the HD CTL 100.
- Utilisez toujours une source d'alimentation fournie ou recommandée par Extron. L'utilisation d'une source d'alimentation non autorisée annule toute conformité réglementaire et peut endommager la source d'alimentation ainsi que le produit final.

Connect the provided 12 VDC, 0.5 A power supply to the HD CTL 100 as follows:

1. Wire one of the supplied orange 2-pole captive screw connectors as shown below.

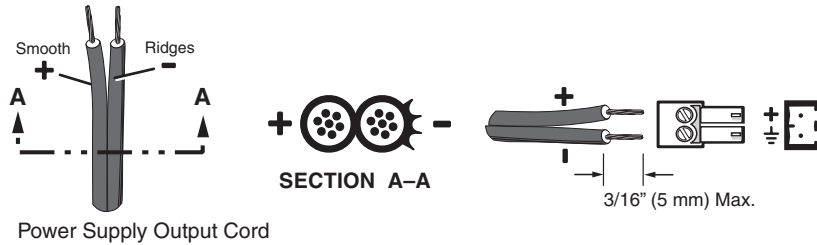
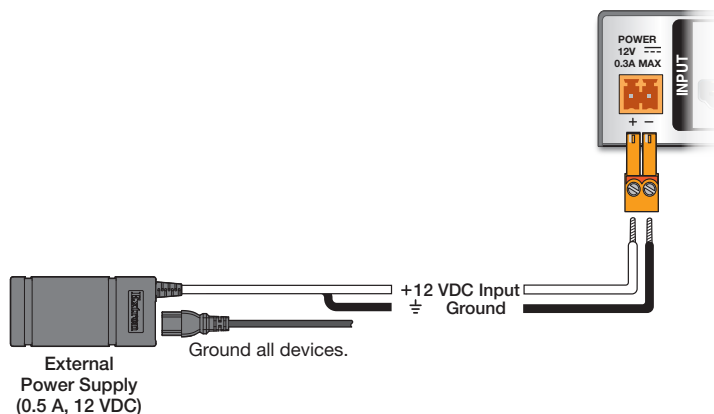

**Figure 9. Wiring the Power Connector**

**ATTENTION:**

- Installation and service must be performed by authorized personnel only. UL listed junction boxes are recommended.
- L'installation et l'entretien doivent être effectués par le personnel autorisé uniquement. Des boîtiers électriques approuvés UL sont recommandés.
- The length of the exposed wires in the stripping process is critical. The ideal length is 3/16 inches (5 mm). If they are any longer, the exposed wires may touch, causing a short circuit between them. If they are any shorter, the wires can be easily pulled out even if tightly fastened by the captive screws.
- La longueur des câbles exposés est primordiale lorsque l'on entreprend de les dénuder. La longueur idéale est de 5 mm (3/16 inches). S'ils sont un peu plus longs, les câbles exposés pourraient se toucher et provoquer un court circuit. S'ils sont un peu plus courts, ils pourraient sortir, même s'ils sont attachés par les vis captives.

2. Plug the connector into the orange 2-pole captive screw power connector on the rear panel. In the example shown in figure 10, a power supply is being connected to the power connector of an HD CTL 100.



**Figure 10. Connecting a Power Supply to an HD CTL 100**

## Front Panel Features

The HD CTL 100 front panel contains the following items:

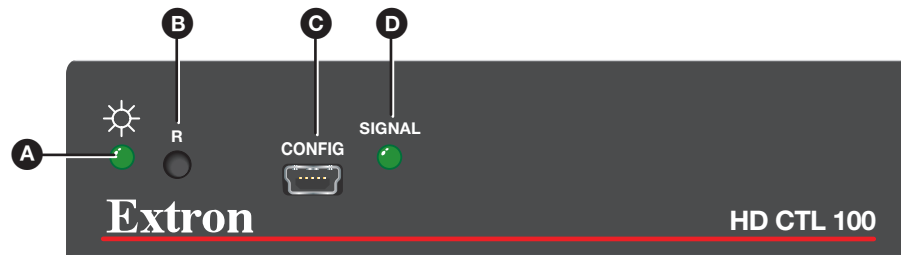

- A Power LED**
- B Reset button**
- C USB configuration port**
- D Signal and Reset LED**

**Figure 11.** HD CTL 100 Front Panel

- A Power LED** — This green LED lights steadily when the unit receives +12 V of power from an external power supply (provided).
- B Reset button** — Using the provided Extron Twecker or other small screwdriver, press this recessed button to initiate a reset to factory firmware or a configuration reset (see [Resetting](#) on the next page).
- C USB configuration port** — Connect a USB A-to-USB mini-B cable between the computer and this port to configure the HD CTL 100 via the configuration software and to update the firmware.
- D Signal and Reset LED** — This green LED lights when an active HDMI source is connected to the rear panel HDMI input port.

When a reset is initiated, this LED also blinks to indicate the progress of the reset (see [Resetting](#) on the next page).

## Resetting

If it becomes necessary to reset the HD CTL 100 to its default factory firmware or to the default configuration settings that were implemented at the factory, you can use the **Reset** button, SIS commands (see the [Reset command](#) on page 27) or the configuration program (see the *HD CTL 100 Configuration Program Help* file).

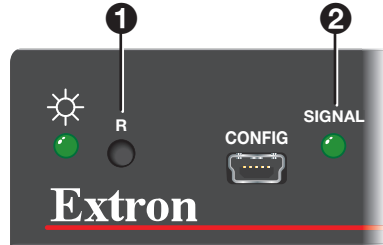

**Figure 12. Reset Button and Signal LED**

Two types of reset are available:

- **Resetting to the default configuration**

1. While the HD CTL 100 is powered on, press and hold the **Reset** button (see figure 12, **1**).
2. After 3 seconds, the Signal LED (**2**) blinks once. Release the button, then immediately (within 1 second) press it again and release it immediately (momentary press).

When the reset is finished, the Signal LED blinks three times, indicating that the reset was successful.

- **Resetting to the factory firmware version**

**NOTE:** This procedure does not reset the configuration on the device.

1. With the HD CTL 100 powered **off**, press and hold the **Reset** button.
2. Continue to hold the button while applying power to the HD CTL 100.
3. When the reset is complete, the Signal/Reset LED blinks three times, then, if a source is connected, remains lit steadily. Release the **Reset** button.

You can also reset the unit to factory defaults using the HD CTL 100 Configuration Program (see the program help file for instructions).

# Remote Configuration and Control

HD CTL 100 can be remotely configured via a host computer that is attached to the front panel USB port using the *HD CTL 100 Configuration Program*. This section describes procedures for obtaining and accessing the configuration software, as well as providing a list of the available SIS commands and the procedures for issuing them.

The following topics are covered:

- [HD CTL 100 Configuration Program](#)
- [SIS Commands](#)

## HD CTL 100 Configuration Program

An HD CTL 100 controller must be configured in order for it to be able to control other devices. The Extron HD CTL 100 Configuration Program enables you to set up the HD CTL 100 rear panel ports and to update firmware. Using this program, you can create configurations on your computer for your HD CTL 100 and then upload them to the controller via the front panel USB port. (The HD CTL 100 does not have to be connected to the computer while you are creating the configurations, only while uploading them.)

See [Installation and Operation](#) starting on page 4, for explanations of the configuration ports. See the configuration program help file to create and upload the configurations.

## Downloading and Installing the Configuration Program

The HD CTL 100 Configuration Program can be downloaded free of charge from the [Extron website](#). To obtain the configuration program, download it to your computer as follows:

1. On the Extron website, hover the mouse pointer over the **Download** tab (see [figure 13](#), **1**, on the next page), then move the pointer to the **Software** link (**2**) in the **Downloads** column and click it.

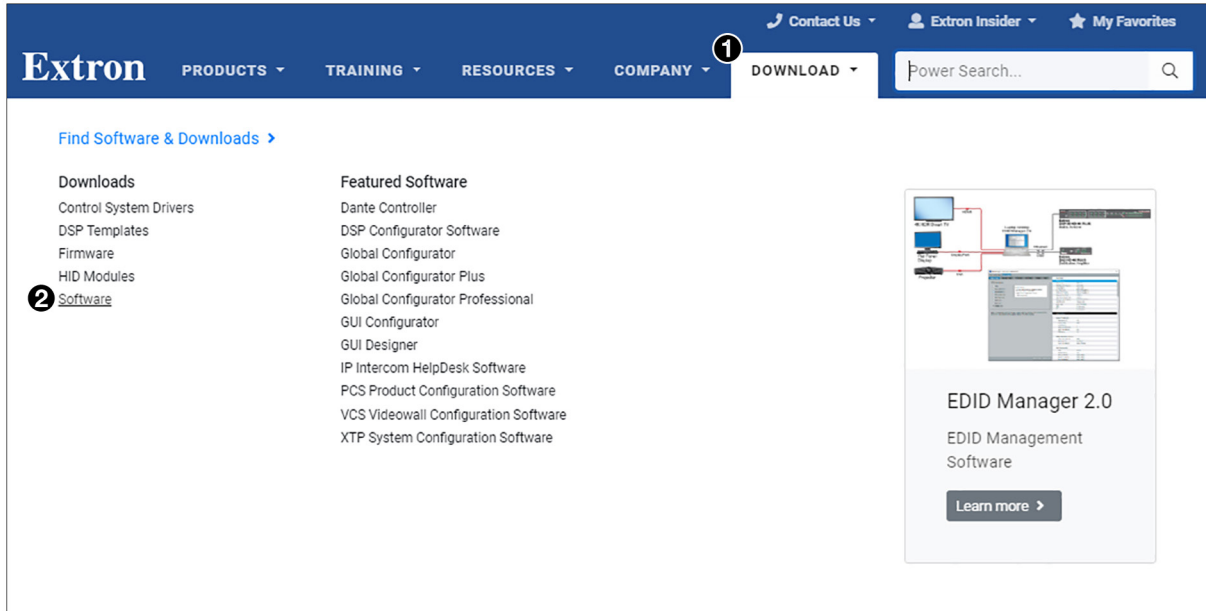

**Figure 13. Software Link on the Download Page**

2. On the Download Center screen, click the **H** link (see figure 14, **1**).

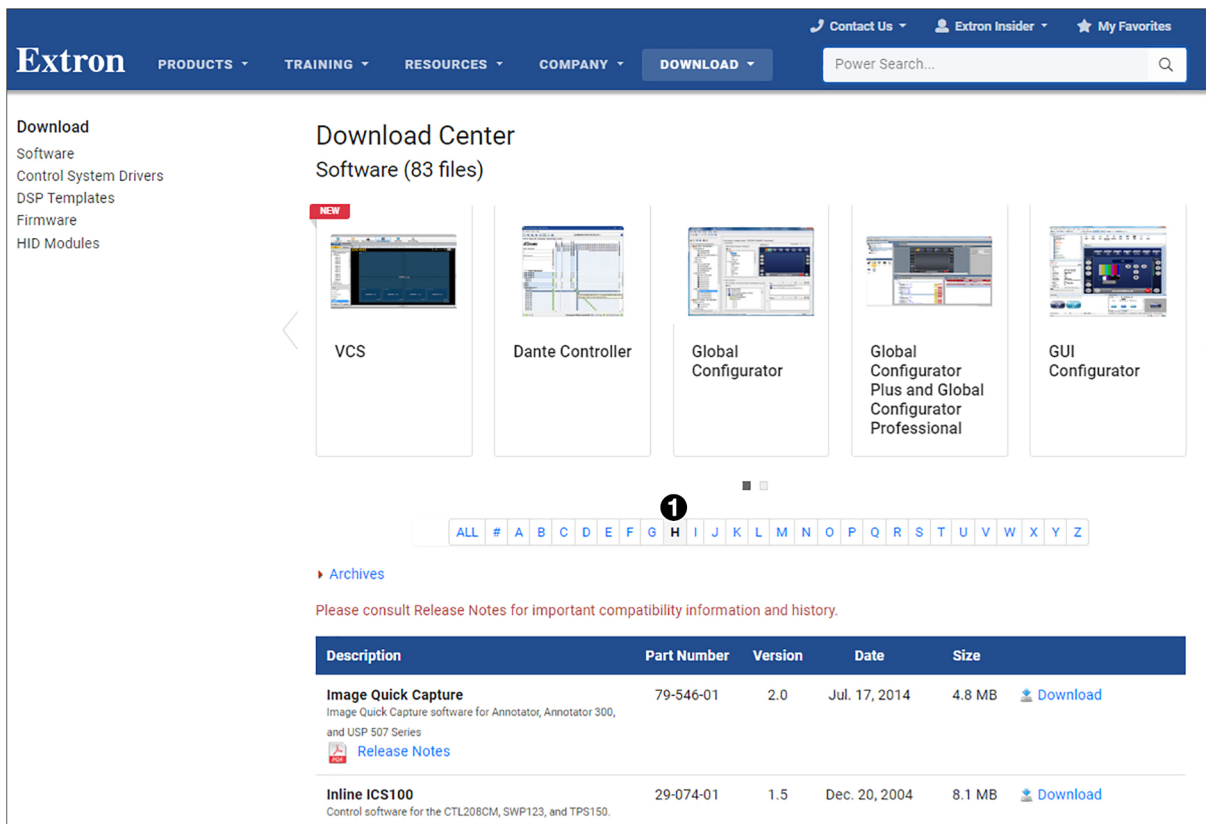

**Figure 14. H Link on Download Center Page**

3. Scroll to locate the HD CTL 100 Configuration Program on the list of available software programs and click the **Download** link to the far right of the name.
4. On the login page that appears next, fill in the required information to log into the [www.extron.com](http://www.extron.com) website (if you need an ID number, see your Extron representative).

5. Follow the instructions on the subsequent screens to complete the software program installation. By default, the configuration program files are stored on your computer at:  
**C:\Program Files (x86)\Extron\HDCTL\_100**

If there is not already an Extron folder in your **Program Files x86** folder, the installation program creates it as well.

## Starting the Configuration Program

To use the HD CTL 100 to control devices, you must create one or more configurations for it, using the HD CTL 100 Configuration Program. A configuration is a set of specifications for command assignments and port parameters that enable the HD CTL 100 to control your display device.

### NOTES:

- Configurations can be created away from the job site and without the HD CTL 100 being connected to the computer.
- **Uploading Configuration Time:** The HD CTL 100 requires approximately one minute to write the configuration to memory **after** the software indicates the process is complete. The completion is indicated with multiple flashes from the power LED on the front panel.
- **Command Ordered List:** When configuring commands within the software, commands in the **Selected Actions** play/execute from the top of the list to the bottom.

After you have downloaded and installed the program (see [Downloading and Installing the Configuration Program](#) on page 14) and device drivers if necessary (see [Obtaining Device Drivers](#) on page 19), begin by creating a new project.

An HD CTL 100 project is a file (with a .mli extension) that contains port configurations for an HD CTL 100. A configuration must be created within a new or existing project. A project can be saved, copied, and edited (for example, by adding or changing configurations within it). You can also create a configuration and add it to an existing project. You can start a new project either when first opening the HD CTL 100 program or while the program is open and another project is active.

To start the configuration program:

1. Open the HD CTL 100 Configuration Program by selecting **HD CTL 100** from the computer **Start** menu. Click:

**All Programs\Extron Electronics\HD CTL 100\HD CTL 100.**

The **Start Options** dialog box opens in front of the HD CTL 100 Configuration Software window.

2. On the **Start Options** dialog box, select the **Create a New Project** radio button (see [figure 15](#), ①, on the next page).

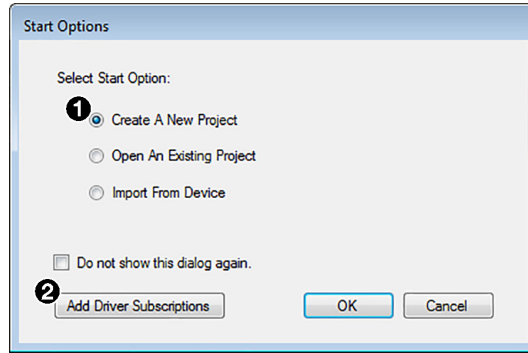

**Figure 15. Start Options Dialog Box**

3. If desired, click the **Add Driver Subscriptions** button (2) to add drivers to the HD CTL 100 (see [Obtaining Device Drivers](#)). You can also add drivers via the software at any time.
4. Click **OK**. The HD CTL 100 Configuration Software main window opens, with **Unnamed Project** displayed in the title bar (see figure 16, 1).

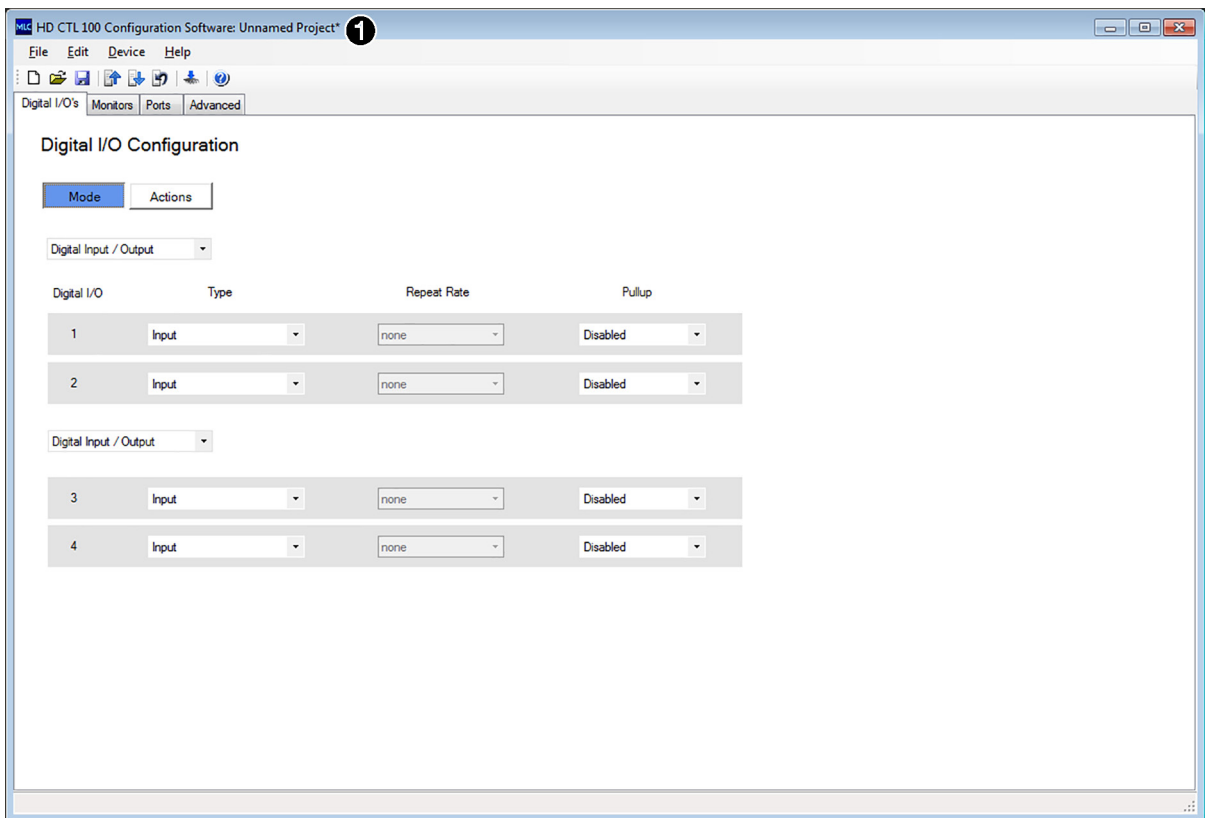

**Figure 16. The HD CTL 100 Main Window**

The following is displayed on the HD CTL 100 main window:

- **Title bar** — In the title bar, the project name is displayed (the asterisk following the name indicates that the project has not been saved since changes were made).

- **Configuration tabs** — Four tabs provide access to screens containing controls that you use to configure the HD CTL 100 (see the configuration program help file for explanations of their contents). From these screens you can:
  - **Digital I/Os (Digital I/O Configuration screen)** — Configure the operation of the four Digital I/O ports and select the operating modes of the devices connected to these ports.
  - **Monitors (Monitor Configuration screen)** — Monitor port and signal status, and set up conditions that trigger selected actions to be performed by devices connected to the ports.
  - **Ports (Port Configuration screen)** — Configure the IR/S port, to which your display device will be connected, and select drivers for the device.
  - **Advanced (Advanced Configuration screen)** — Select power timeout, warm-up, and cool down settings.
- **Menu bar** — The menu bar contains four drop-down menus from which you can select options to manage new and saved projects, obtain device drivers, upload firmware, display this help file, and more. Many of the functions accessed from these menu options also are available as buttons on the toolbar.

When you place the mouse pointer over a button on the toolbar, the function of the button is displayed as pop-up text, called a **tooltip** (see the example in figure 17).

- **Toolbar** — Located below the menu bar on the main window the toolbar contains buttons that enable you to manage HD CTL 100 projects and device configurations, upload firmware, and access the *HD CTL 100 Configuration Program Help*. Many of the functions accessed by these buttons also are available as options on the menus.

When you place the mouse pointer over a button on the toolbar, a **tooltip** pops up, explaining the button function (see the example in figure 17).

5. Save and name a project as follows:
  - a. From the **File** menu, select **Save As . . .**
  - b. In the **Save As** dialog box, give your project file a name and save it to the desired location on your computer.

**NOTE:** Your project is saved as a file with the extension **.hdc**.

You are now ready to create configurations for your HD CTL 100 device by specifying parameters for its ports (see the configuration program help file for procedures).

### Accessing the help file

For instructions on creating configurations using the program, see the *HD CTL 100 Configuration Program Help* file. You can access the help file when the configuration program is open using any of the following methods:

- From the **Help** menu, select **HD CTL 100 Configuration Program Help**.

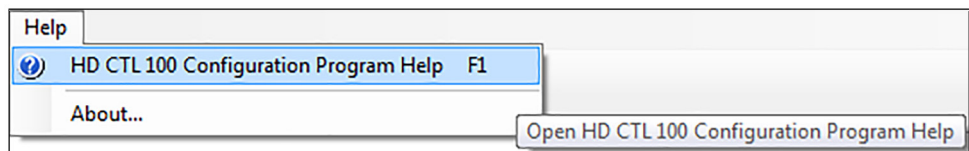

**Figure 17. Configuration Program Help Menu**

- Click the **Help** icon on the main window toolbar (see figure 18, ❶). (When you hover the mouse pointer over a toolbar icon, a pop-up explanation of its function appears (see figure 18).



**Figure 18. Help Icon on Configuration Program Toolbar**

- Press the <F1> key on your computer keyboard.

## Obtaining Device Drivers

The Extron drivers are control files (libraries) of commands created by Extron that are specific to a particular display device or switcher. There are different sets of drivers for serial (RS-232) and IR control. Before you can use the configuration program to configure the HD CTL 100 ports, the necessary drivers must be loaded onto your computer. You must then select the driver appropriate to the HD CTL 100 for your device in order to configure it to control the device. Serial and IR drivers are available at no charge from [www.extron.com](http://www.extron.com). You can download them directly from the web or through the configuration program.

**NOTES:** By default the downloaded drivers are stored in the Driver2 folder on your computer, located at `c:\Users\Public\Documents\Extron\Driver2`

## Downloading drivers using the configuration program

The easiest way to obtain the drivers for your devices is via the HD CTL 100 configuration program. You can initiate this process by two methods:

- Click the **Add Driver Subscriptions** button on the **Start Options** dialog box (described below).
- Select **Driver Subscriptions** from the **Edit** menu on the main window (you can do this at any time while the program is open, regardless of whether a project has been created).

**NOTE:** Your computer must have an active internet connection to download drivers.

1. Click **Start\All Programs\Extron Electronics\HD CTL 100\HD CTL 100** or double-click the **HD CTL 100 software** icon (shown at right), which is placed on your desktop during software installation, to launch the HD CTL 100 Configuration Program application. The HD CTL 100 Configuration Program main window opens, with the **Start Options** dialog box displayed in front of it.
2. On the **Start Options** dialog box, click the **Add Driver Subscriptions** button (see **figure 19**, ❶, on the next page).



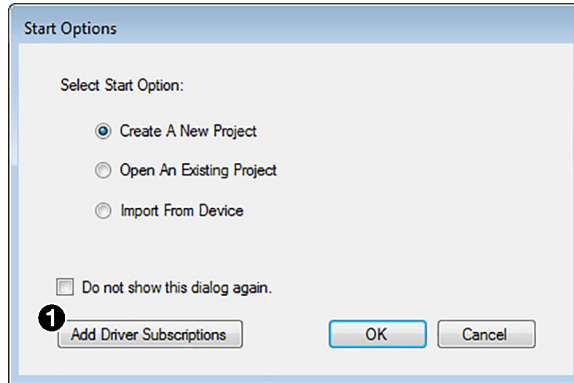

**Figure 19. Start Options Dialog Box**

3. In the Available Drivers Subscription panel of the Driver Subscriptions dialog box, select the device types for which you want to download drivers (see figure 20).

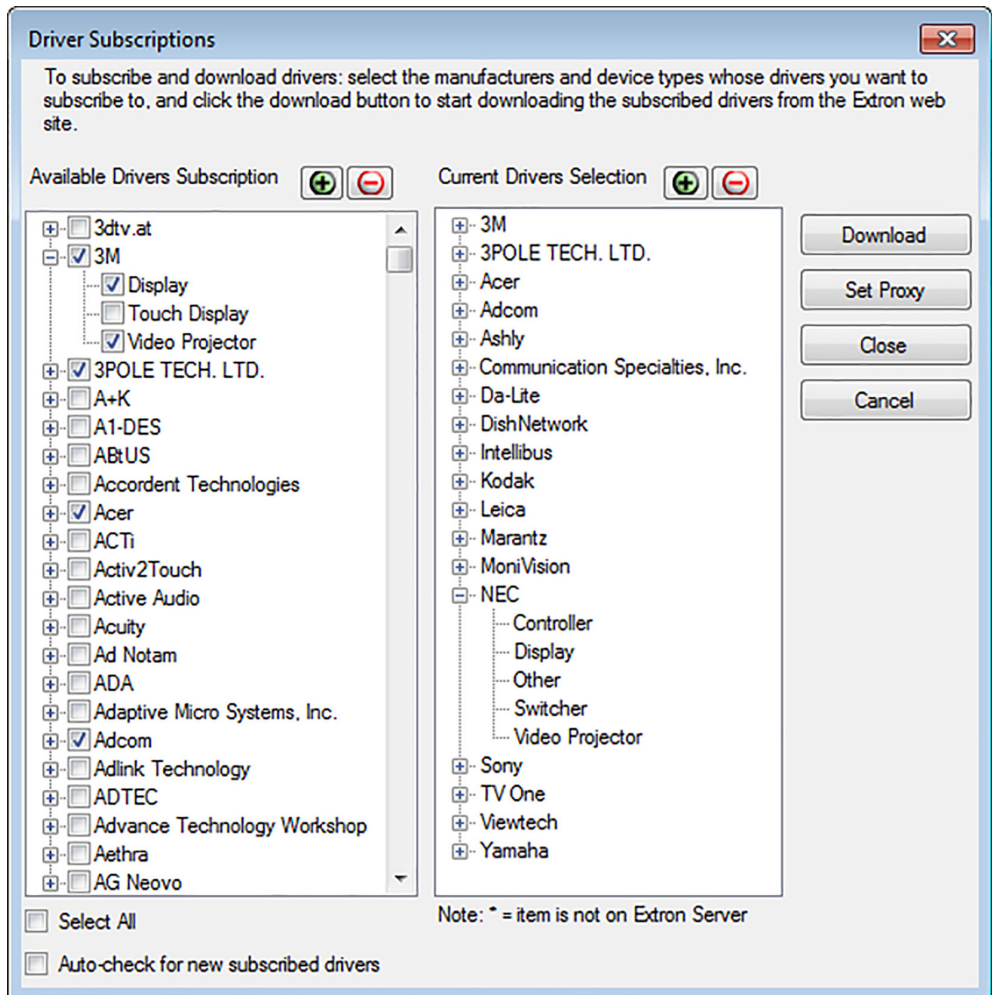

**Figure 20. Driver Subscription Dialog Box**

- **To select all device types** available from a manufacturer, select the checkbox in front of the manufacturer name. Each manufacturer whose drivers you select is listed in the **Current Drivers Selection** column.
- **To select individual device types** from a manufacturer, click the plus (+) sign in front of the manufacturer name to expand it and display all the device types of that manufacturer for which drivers are available, then select the desired device check boxes. To hide the devices, click the minus (-) sign.
- **To expand or collapse the list** of manufacturers and view or hide all their drivers, click the **Expand all** or **Collapse all** buttons (shown at right) at the top of either column.



**NOTE:** When you select a device, both the IR and serial drivers for it are downloaded.

4. Make any desired optional selections:
  - Select the **Auto-check for new subscribed drivers** checkbox if you want the HD CTL 100 to continually check for and download any updates to your subscribed drivers. When a new version of any of your subscribed drivers is available on the Extron website, that new version is automatically downloaded when the configuration program is started.
  - Click **Set Proxy** if you want to download your drivers using proxy server settings (see the configuration program help file for more information).

If you want to close the dialog box without downloading any drivers, click **Close** to save any changes you have made on this dialog box or **Cancel** if you want to discard your changes.

5. Click **Download**. The **Driver Subscriptions Download** dialog box opens, displaying all drivers that have been selected or previously downloaded to your computer (see figure 21).

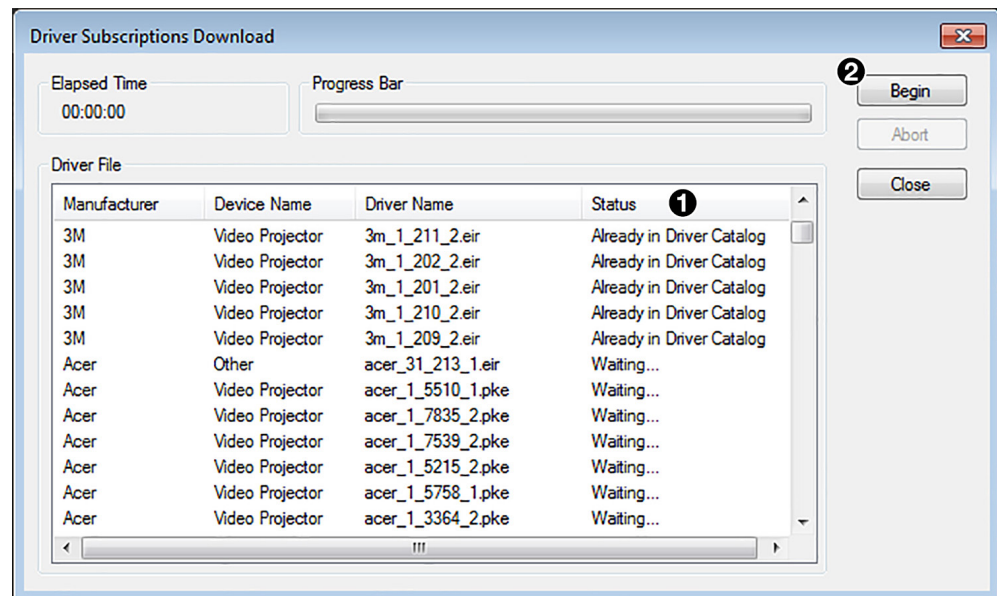

**Figure 21. Driver Subscriptions Download Screen**

- If a driver on the list is new for your computer, it has the designation **Waiting...** in the **Status** column (1).
- If a driver already exists on your computer, its designation is **Already in Driver Catalog**.

6. In the **Driver Subscriptions Download** dialog box, click **Begin** (2) to download the drivers listed in the **Driver File** panel. While the download is in progress:
  - The **Elapsed Time** panel (see figure 22, 1, on the next page) shows the amount of time that has passed since the download process started.
  - The **Progress Bar** (2) indicates the progress of the download.
  - As each new driver is downloaded, its designation in the **Status** column changes to **Completed** (3).
7. When the **Progress Bar** (see figure 22, 2) and the **Status** column (3) indicate that the download has completed, click **Close** (4) to close the **Driver Subscriptions Download** dialog box.

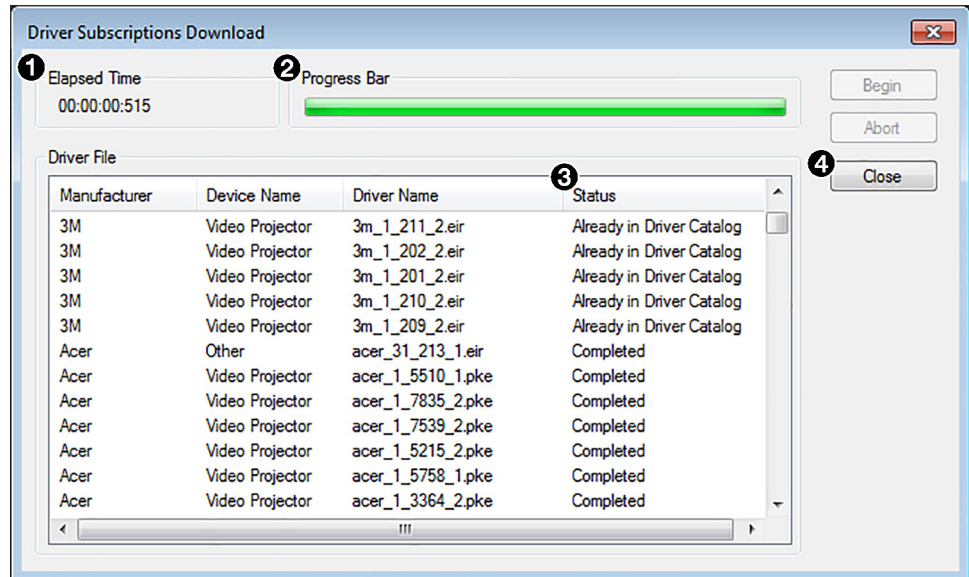
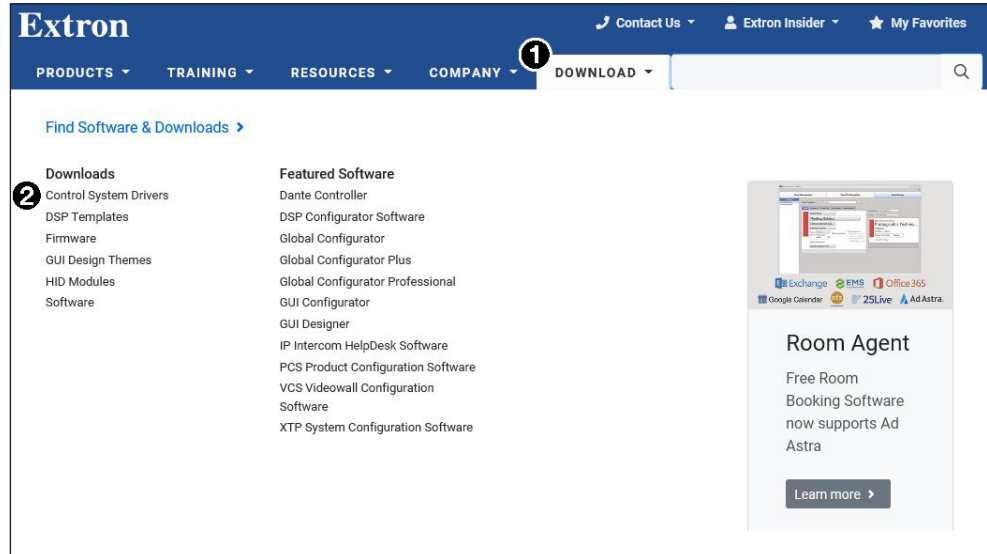

**Figure 22. Driver Subscriptions Download Screen after a Driver Download**

## Downloading drivers from the Web

Drivers can also be obtained directly from the Extron website without using the control program as follows:

1. Go to [www.extron.com](http://www.extron.com), and mouse over the **Download** tab (see figure 23, ❶) at the top of the page.
2. On the **Download** screen, click the **Control System Drivers** link (❷) on the left sidebar.



**Figure 23. Control System Drivers Links on the Download Screen**

The Control System Drivers page opens (see [figure 24](#) on the next page).

3. From the **Extron Product** menu (❶) on the **Control System Drivers** screen, select **HD CTL 100** if it is not already selected. The other menus become available.

## Control System Drivers

### Popular Pro Series Downloads

- [Extron - Universal Display Driver \(Serial,TCP\) \(Login required\)](#)
- [Polycom - RealPresence Group 700 \(Serial,TCP\) \(Login required\)](#)
- [Sharp - PN-LE901 \(Serial,TCP\) \(Login required\)](#)
- [Extron - IN1608 xi \(Serial,TCP\) \(Login required\)](#)
- [Extron - DTP CrossPoint 108 4K \(Serial,TCP\) \(Login required\)](#)

### Featured Pro Series Downloads

- [Extron - Universal Device Driver, Unidirectional RS232 and TCP \(Serial, TCP\) \(Login required\)](#)
- [Extron - Universal Display Driver, Bidirectional \(Login required\)](#)
- [Extron - Cisco Touch 10](#)
- [Trend - IQ3 \(Login required\)](#)
- [Elka - Gateway \(Serial, TCP\) \(Login required\)](#)

### Control System Driver Search

Extron Product

1 HD CTL 100

- IPL T S2
- IPL T S4
- IPL T S6
- IPL T SF24
- IPL T SF1244
- MLC 104 IP Plus Series
- MLC 104 IP Series
- MLC 104 Series
- MLC 206 Series
- MLC 226 IP Series
- MLC 52 IR
- MLC 52 RS
- MLC 55 Series
- MLC 60 Series
- MLC Plus 50
- MLC Plus 100 Series
- MLC Plus 200 Series
- MLC Plus 84 Series
- System 5 IP
- System 5cr

Protocol Type

2 Serial

Manufacturer

3 All

Product Category

4 All

Model

5 All

included in the current package

er package (Login required)

ent driver package (Login required)

D E F G H I J K L M N O P Q R S T U V W X Y Z

ly added and are not included in the current driver package.

Model Number	Product Category	Interface	Version	Date Posted	Driver	Communication Sheet	Extron Certified
<a href="#">3dtv.at - Stereoscopic Player (Login required)</a>	Other	Serial	1	Feb. 14, 2012	24 KB (Login required)	27 KB (Login required)	
<a href="#">3M - C3266PW (Login required)</a>	Touch Display	Serial	1	Jun. 26, 2015	35 KB (Login required)	34 KB (Login required)	

**Figure 24. Selecting HD CTL 100 from the Device Drivers Drop-down Menu**

4. From the rest of the menus on the screen, select search criteria for the drivers you want to download:
  - From the **Protocol Type** menu (2), select **IR**, **Serial**, or **All**.
  - From the **Manufacturer** menu (3), select the manufacturer of the device for which you are downloading the drivers, or **All** to select all device manufacturers.
  - From the **Product Category** menu (4), select the type of device (for example, video projector) or **All**.
  - From the **Model** menu (5), select the device model name or number, or **All**.

As you make each selection, the driver list below changes to display all available drivers meeting your selected criteria.

5. Click on the device name whose driver you want to download.

To download all the drivers in the current package, click the **Download install for current driver package (Login required)** link (see figure 25, ❶).

**Control System Driver Search**

Extron Product: HD CTL 100 | Protocol Type: Serial | Manufacturer: All | Product Category: All | Model: All

Check to view only drivers not included in the current package

❶ [Download install for current driver package \(Login required\)](#)

[Download release notes for current driver package \(Login required\)](#)

[View archived drivers](#)

**Figure 25. Download Install for Current Driver Package Link**

**NOTE:** The website may contain additional drivers that became available after the current driver package was created. These new drivers may be on the website, but have not been incorporated into the driver package.

If you want to ensure that you are getting all the drivers currently available, use the configuration program to download the drivers (see [Downloading drivers using the configuration program](#) on page 19).

6. On the next screen, enter the requested information. If you need an ID number (password), contact your Extron representative.
7. Follow the directions on the download screens that follow. Unless you specify otherwise, the driver file is placed at:  
c:\Users\Public\Documents\Extron\Driver2

## CEC Control

CEC can control standard functions on a display attached to the HDMI output by inserting unidirectional CEC control commands. These commands are available to be issued via the HD CTL 100 Configuration Program (see the program help file for instructions on using the commands).

The following CEC commands are included in the HD CTL 100 firmware:

- Power on
- Power off
- Input selection
- Volume up
- Volume down
- Audio mute (toggle on and off)

Using the configuration program, you can configure CEC commands to be sent to the output device when:

- A digital input is triggered.
- Signal presence is detected or not detected.
- An action detected by a monitor (also set up via the configuration program) is triggered.

You can also insert user-defined CEC commands to be issued to the display (see the *HD CTL 100 Configuration Program Help* file for the procedure).

## Default functionality

The HD CTL 100 is preconfigured with the following monitors and actions, which can be reconfigured via the HD CTL 100 Configuration Program (see the program help file).

- When a stable HDMI (TMDS) signal is detected, the HD CTL 100 sends the CEC **Power On** command to the connected sink (display).
- When no HDMI (TMDS) signal is present for 30 seconds, a CEC **Power Off** command is sent to the connected sink.

You can reconfigure these monitors and actions using the HD CTL 100 Configuration Program (see the program help file).

## SIS Commands

You can issue SIS commands to the HD CTL 100 via the USB interface of your computer or control device with a communication software program such as Extron DataViewer.

### Host-to-Controller Communications

SIS commands consist of strings of one or more characters per field. No special characters are required to begin or end a command sequence. When the HD CTL 100 determines that a command is valid, it executes the command and sends a response to the host device.

Most responses from the HD CTL 100 to the host end with a carriage return and a line feed (CR/LF = **↵**), which signals the end of the response character string.

### Controller-initiated Messages

When a local event takes place, the HD CTL 100 responds by sending a message to the host, indicating what selection was entered. No response is required from the host.

### Error Responses

If the HD CTL 100 is unable to execute a command it receives because the command is invalid or contains invalid parameters, the controller returns an error response to the host. This response consists of the letter E followed by a number and a carriage return with a line feed. The following error response codes can be returned:

E10 – Invalid command or parameter

E13 – Invalid value (out of range)

### Using the Command and Response Table

The [Command and Response Table for SIS Commands](#) on page 27 lists valid ASCII command codes, the responses of the HD CTL 100 to the host, and a description of the command function or the results of executing the command. The [ASCII to Hex Conversion Table](#) on the next page is for use with the Command and Response Table.

ASCII to HEX Conversion Table										Esc 1B	CR 0D	LF 0A		
Space 20	!	21	"	22	#	23	\$	24	%	25	&	26	'	27
( 28	)	29	*	2A	+	2B	,	2C	-	2D	.	2E	/	2F
0 30	1	31	2	32	3	33	4	34	5	35	6	36	7	37
8 38	9	39	:	3A	;	3B	<	3C	=	3D	>	3E	?	3F
@ 40	A	41	B	42	C	43	D	44	E	45	F	46	G	47
H 48	I	49	J	4A	K	4B	L	4C	M	4D	N	4E	O	4F
P 50	Q	51	R	52	S	53	T	54	U	55	V	56	W	57
X 58	Y	59	Z	5A	[	5B	\	5C	]	5D	^	5E	_	5F
` 60	a	61	b	62	c	63	d	64	e	65	f	66	g	67
h 68	i	69	j	6A	k	6B	l	6C	m	6D	n	6E	o	6F
p 70	q	71	r	72	s	73	t	74	u	75	v	76	w	77
x 78	y	79	z	7A	{	7B		7C	}	7D	~	7E	DEL	7F

**NOTE:** For commands and examples of computer or device responses used in this guide, the character "0" is the number zero and "O" is the capital letter "o".

## Symbol Definitions

- ↵ = CR/LF (carriage return with line feed) (hex 0D 0A)
- ← or | = Soft carriage return (no line feed) (hex 0D)
- = Space
- Esc or W = Escape key (hex 1B)

**NOTE:** Unless otherwise indicated, commands are **not** case-sensitive.

- X1 = Input signal status
  - 0 = No input signal detected
  - 1 = Input signal detected
- X2 = Unit name — Text string of up to 24 alphanumeric characters and the hyphen (-).
  - Spaces are not permitted.
  - First character must be a letter.
  - Last character cannot be a hyphen.
- X3 = Firmware version number (displayed to two decimal places: *n.nn*)
- X4 = +5 V output mode
  - 0 = Auto: +5 V is enabled only when a source with +5 V is present
  - 1 = +5 V is always enabled (default)
- X5 = Verbose mode
  - 0 = Clear/none
  - 1 = Verbose mode (default)
  - 2 = Tagged response for queries
  - 3 = Verbose mode and tagged response for queries

## Command and Response Table for SIS Commands

Command	ASCII Command (Host to Unit)	Response (Unit to Host)	Additional Description
<b>Signal Status</b>			
Request input signal status	<b>Esc</b> LS ← <i>Verbose mode 2 and 3</i>	1 * <b>X1</b> ← Sig1 * <b>X1</b> ←	View input 1 signal presence <b>X1</b> .
<b>Device Name</b>			
Set unit name	<b>Esc</b> <b>X2</b> CN ←	Ipn* <b>X2</b> ←	Set the name of the HD CTL 100 to <b>X2</b> .
Set unit name to factory default	<b>Esc</b> • CN ←	Ipn•HD-CTL-100 ←	Reset the unit name to its factory default name: HD-CTL-100.
View unit name	<b>Esc</b> CN ← <i>Verbose mode 2 and 3</i>	<b>X2</b> ← Ipn* <b>X2</b> ←	Show the name ( <b>X2</b> ) of the HD CTL 100.
<b>Information Requests</b>			
Query firmware version	Q <i>Verbose mode 2 and 3</i>	<b>X3</b> ← Ver01* <b>X3</b> ←	Display firmware version <b>X3</b> to two decimal places.
Query part number	N <i>Verbose mode 2 and 3</i>	60 - 1633 - 01 ← Pno60 - 1633 - 01 ←	Show the part number of the unit.
<b>+5 V Output Mode</b>			
Set +5 V output mode	<b>Esc</b> M <b>X4</b> HPLG ←	Hp1gM <b>X4</b> ←	Select +5 V output mode
View +5 V output mode status	<b>Esc</b> MHPLG ← <i>Verbose mode 2 and 3</i>	<b>X4</b> ← Hp1gM <b>X4</b> ←	View current +5 V output mode
<b>Verbose Mode</b>			
Set verbose mode	<b>Esc</b> <b>X5</b> CV ←	Vrb <b>X5</b> ←	
View verbose mode	<b>Esc</b> CV ← <i>Verbose mode 2 and 3</i>	<b>X5</b> ← Vrb <b>X5</b> ←	
<b>Reset</b>			
Reset to defaults	<b>Esc</b> ZXXX ←	Zpx ←	Reset the HD CTL 100 to the factory defaults.
<b>KEY:</b>			
<b>X1</b> = Input 1 signal status 0 = No input signal detected 1 = Input 1 signal detected.			
<b>X2</b> = Unit name: Text string of up to 24 alphanumeric characters and the hyphen (-). • Spaces are not permitted. • First character must be a letter. • Last character cannot be a hyphen.			
<b>X3</b> = Firmware version (displayed to two decimal places)			
<b>X4</b> = +5 V output mode 0 = Auto: +5 V is enabled only when a source with +5 V is present 1 = +5 V is always enabled (default).			
<b>X5</b> = Verbose mode 0 = Clear/none 1 = Verbose mode (default) 2 = Tagged response for queries 3 = Verbose mode and tagged response for queries			

# Application Example

This section describes an example of a typical HD CTL 100 power control application that includes a variety of devices. The system illustrated in figure 26, below, and [figure 27](#), on the next page, is designed to control the display power by three different methods: input signal detection, contact closure, and occupancy sensor.

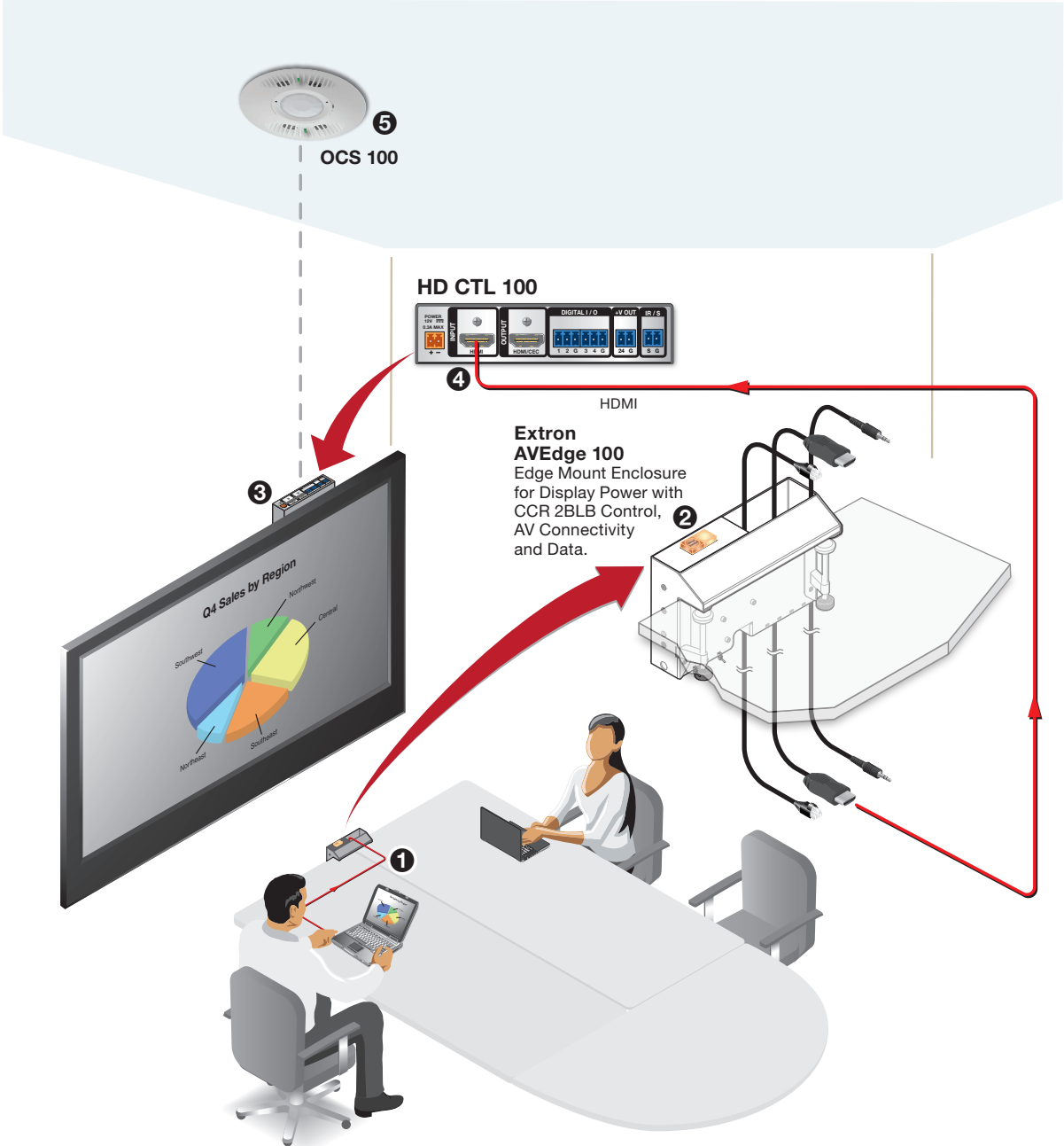

Figure 26. Application Example

This section contains instructions for using the configuration software to set up the power control in the following three ways:

- Detection of the input source signal (see [Input Signal Detection](#) on page 31)
- A two-button contact closure device (an Extron CCR 2BLB, see [Contact Closure Device](#) on page 33)
- Detection of room occupancy by an occupancy sensor (such as an Extron OCS 100, see [Occupancy Sensor](#) on page 34)

## Connection Description

For this HD CTL 100 application, the following devices are connected:

- The source is a laptop PC, placed on a tabletop (see [figure 26, 1](#), on the previous page).
- A CCR 2BLB two-button contact closure device is installed in an AVEdge cable access enclosure ([2](#)) that is clamped to the tabletop near the laptop.
- The HD CTL 100 ([3](#)) is mounted to the wall, behind the display device.
- The HDMI cable of the laptop passes through the AVEdge and connects to the HD CTL 100 input ([4](#)).

Figure 27 shows the wiring connections for this application.

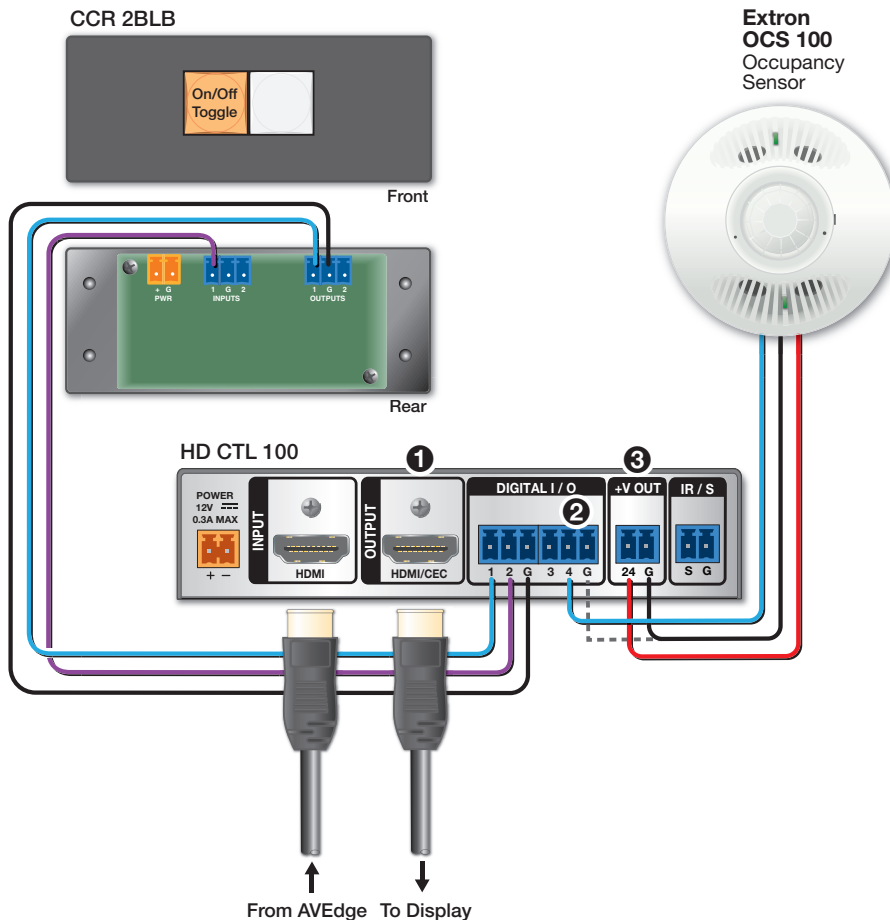

**Figure 27. Wiring for the Power Control Application**

- The HDMI cable of the display is attached to the output connector of the HD CTL 100 (see [figure 27, 1](#)).

- The CCR 2BLB is wired to Digital I/O ports 1 and 2 of the HD CTL 100 (port 1 is set as the input and port 2 is set as the output).
- An occupancy sensor is mounted on the ceiling (see [figure 26](#), [5](#), on [page 29](#)) and is wired to:
  - Digital I/O port 4 of the HD CTL 100, which is configured as an input (see [figure 27](#), [2](#), on the previous page)
  - The +VC Out connector of the HD CTL 100 ([3](#)), which provides +24 V of power to the sensor

## Configuring the Application Using the Software

The HD CTL 100 Configuration Software enables you to set up the controller to power the display on and off at desired times or in response to specified conditions. To obtain the software, see [Downloading and Installing the Configuration Program](#) on page 14. See the *HD CTL 100 Configuration Program Help File* (accessible via the **Help** menu within the configuration program) for detailed information on using the software to configure the controller. The three power on and off methods used in this application are described in the following sections.

### NOTES:

- Configurations can be created away from the job site and without the HD CTL 100 being connected to the computer.
- **Uploading Configuration Time:** The HD CTL 100 requires approximately one minute to write the configuration to memory **after** the software indicates the process is complete. The completion is indicated with multiple flashes from the power LED on the front panel.
- **Command Ordered List:** When configuring commands within the software, commands in the **Selected Actions** play/execute from the top of the list to the bottom.

## Input Signal Detection

By default, the controller is configured to power the display on when an HDMI source signal is present, and to power it off when no signal is detected for 30 seconds. The **Monitor Configuration** screen is already set up by default to do this, and these default settings are used to configure powering on and off via input signal detection.

### Monitor screen defaults

[Figure 28](#) on the next page shows the **Monitor Configuration** screen defaults.

**NOTE:** You can easily change these default settings or add new actions if desired. See the *HD CTL 100 Configuration Software Help File* for instructions.

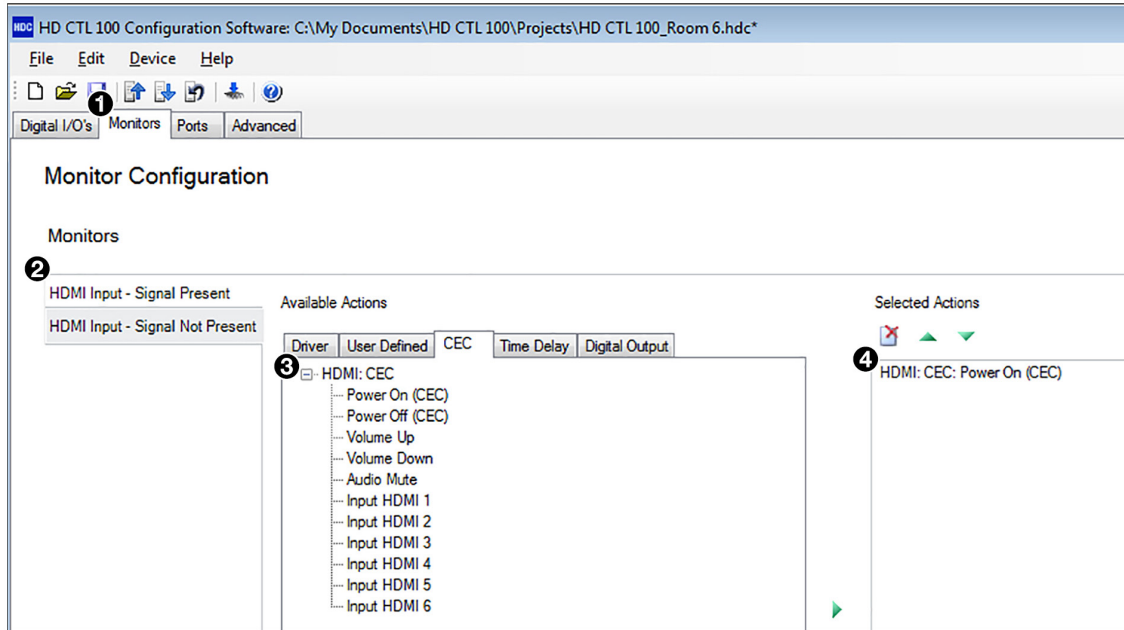

**Figure 28. Monitor Configuration Screen**

- 1 **Monitors tab** — On the HD CTL 100 Configuration Software main window, select this tab to display the Monitor Configuration screen.
- 2 **HDMI Input - Signal Present and HDMI Input - Signal Not Present side tabs** — By default, the **HDMI Input - Signal Present** tab is selected, displaying the screen containing the **Available Actions** and **Selected Actions** panels for an input signal present condition.

**NOTE:** The selected tab is the one NOT shaded.

To view the actions that have been assigned by default to be performed if no input signal is present, select the **HDMI Input - Signal Not Present** side tab. The screen that is displayed is identical to the **Signal Present** screen shown in figure 28, but with the addition of a **Signal Not Present Timer** field in the lower-left corner (see figure 29).



**Figure 29. Signal Not Present Timer Field on the HDMI Input - Signal Not Present Screen**

By default, this field is set to **30 secs**, which means that the controller powers off the display after 30 seconds if no input signal is detected.

- 3 By default, the **CEC** tab is selected in the **Available Actions** panel, displaying all the available HDMI CEC commands (see figure 28, 3).
- 4 By default, the **HDMI CEC: Power On (CEC)** command is added to the **Selected Actions** panel. This causes the HD CTL 100 to power on the display when an input signal is detected.

**NOTE:** You can also use serial or IR commands to control power of the display.

## Contact Closure Device

Another method of powering the display on and off is via a contact closure device. In this application, a CCR 2BLB two-button switch is connected to Digital I/O port 1. Only button 1 of the switch is used in this application, button 2 is not configured (see figures 26 and 27 for connection information). To configure button 1 of the CCR 2BLB to power the display on and off, use the **Digital I/O** screens as follows:

1. When the HD CTL 100 Configuration Software is opened, the **Digital I/O's** tab is selected by default. If this tab is not selected, click it.
2. By default, the **Mode** screen is displayed with the **Digital I/O's** tab is selected. If it is not, click the **Mode** button (see figure 30, ①).

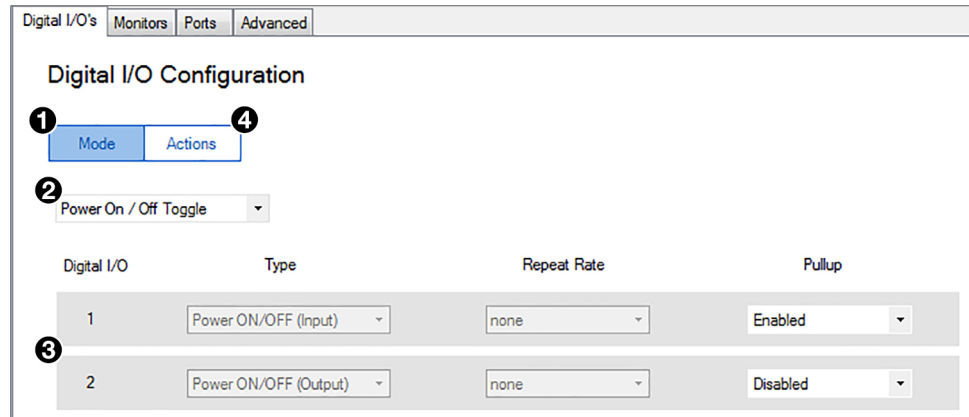

**Figure 30. Digital I/O Mode Screen, Power On / Off Toggle Mode Selected**

3. On the Digital I/O Mode screen, select **Power On / Off Toggle** (②).  
When this mode is selected, Digital I/O ports 1 and 2 (③) are configured in Power On/Off (Toggle) mode. (Power On/Off (Toggle) mode is available for only ports 1 and 2, however, ports 3 and 4 can be configured in other modes with different devices attached).
4. Click the **Actions** button (④) to display the **Available Actions** and **Selected Actions** panels.
5. In the **Available Actions** panel, select the **CEC** tab (see figure 31, ①).

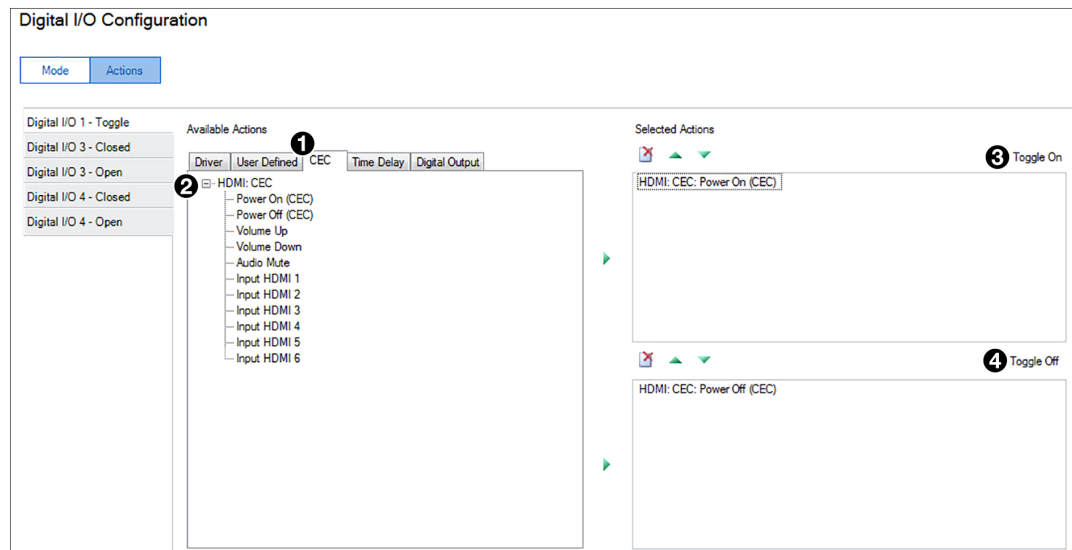

**Figure 31. Configuring Digital I/O Port 1 in Power On/Off (Toggle) Mode**

- Click the + sign (2) to expand the list of CEC commands, and drag the **Power On (CEC)** action to the **Toggle On** (top) panel to the right (3). This causes the controller to send a command to the display to power **on** when the CCR 2BLB button is first pressed.

When the CCR 2BLB button is pressed to power the display on, the button blinks **rapidly** for approximately 10 seconds, then remains lit steadily.

**NOTE:** The number of seconds of warm-up and cool-down can be configured via the Advanced screen of the HD CTL 100 Configuration software (see the *HD CTL 100 Configuration Software Help* file for more information).

- Drag the **Power Off (CEC)** action from the **Available Actions** panel to the **Toggle Off** (bottom) panel (4). This causes the controller to send a command to the display to power **off** when the same CCR 2BLB button is pressed again.

(Alternatively, you can select each desired action in the **Available Actions** panel, then click the green arrow between the panels to move the action to the **Selected Actions** panel.)

When the CCR 2BLB button is pressed to again to power off the display, the button blinks **slowly** for approximately 10 seconds, then remains dimly lit.

## Occupancy Sensor

In this application, another means of powering on the display is by wiring a room occupancy sensor, such as the Extron OCS 100, to the HD CTL 100 Digital I/O port 4, which is configured as an input. The sensor is mounted to the ceiling (figure 26 on page 29). For the application, the HD CTL 100 is configured to power on the display when the occupancy sensor detects that the room is occupied, and to power it off after a specified period of no room occupancy.

### Digital I/O port states

The occupancy sensor is connected to Digital I/O port 4, which must be configured in order for the sensor to trigger the desired power on and off actions. The Digital I/O port can be in either of two states: open — (high) and closed (low). Each port consists of two pins, signal and ground (one ground pin is shared between ports 1 and 2, while the other is shared between ports 3 and 4).

Between the signal and ground pins, a circuit is either formed or broken when the occupancy sensor is activated.

- The sensor provides approximately 21 VDC in the On (high or open) state and 0 VDC in the Off (low or closed) state. When wiring the blue or gray wires of the OCS to Extron products with digital input ports, configure the ports as input with pullup **disabled**, because the sensor has its own power supply.
- When the sensor detects motion, it instantly triggers an On state. Once occupancy is no longer detected, the timer begins. If no motion is detected and the time expires, then the sensor triggers the Off state.

## Digital I/O port configuration procedure

To configure actions to be triggered by the two states of the occupancy sensor:

1. Select the **Digital I/O's** tab (see figure 32, ❶).

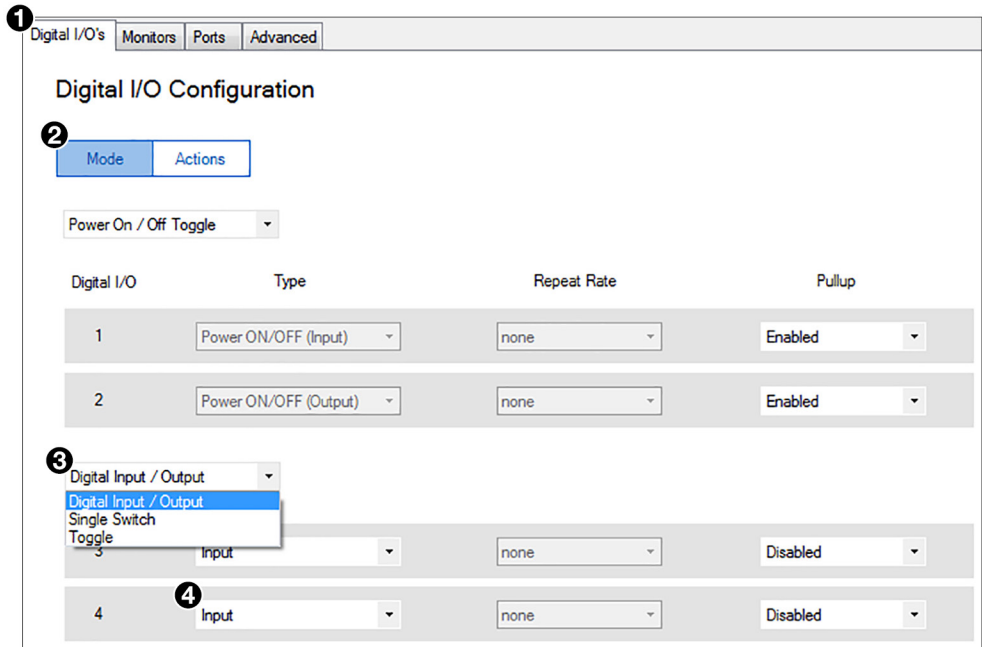

**Figure 32.** Configuring Digital I/O Port 4 as an Input for the Occupancy Sensor

2. On the Digital I/O Configuration screen, click the **Mode** button (❷).
3. From the second mode menu, located above the Digital I/O Port 3 panel (❸), select **Digital Input / Output**.
4. From the port 4 Type menu (❹), select **Input** to configure port 4 as an input.
5. Click the **Actions** button to display the Available Actions and Selected Actions panels.
6. In the left column of the Actions screen, select the **Digital I/O 4 - Closed** side tab (see figure 33, ❶).

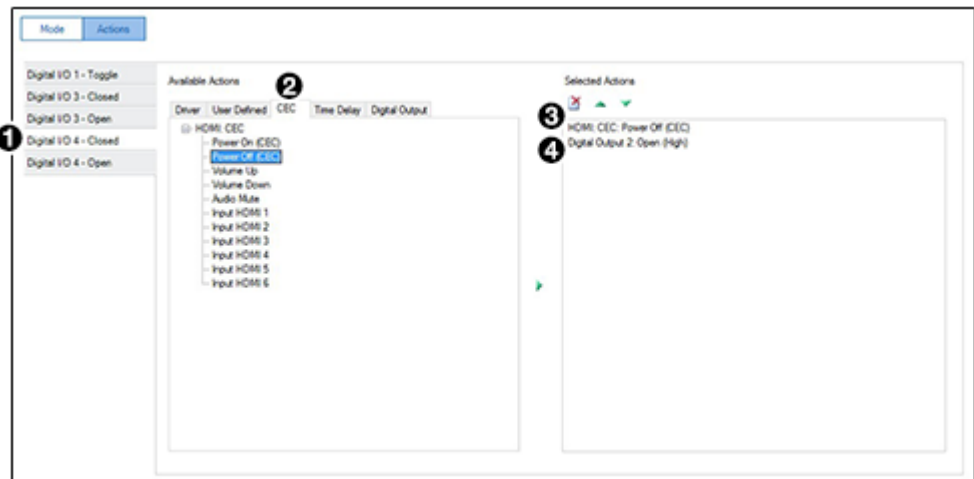

**Figure 33.** Adding the Power On (CEC) Action to the Digital I/O Port 4 Closed State

7. In the Available Actions panel, select the **CEC** tab (2) and click the + sign to expand the list of HDMI CEC actions.
8. Drag the **Power Off (CEC)** action to the Selected Actions panel on the right (3). This causes the HD CTL 100 to send a display power off command when the timer on the occupancy sensor no longer detects that anyone is in the room.
9. To configure the Open state of Digital I-O 4, select the **Digital I/O 4 - Open** side tab (see figure 34, 1).

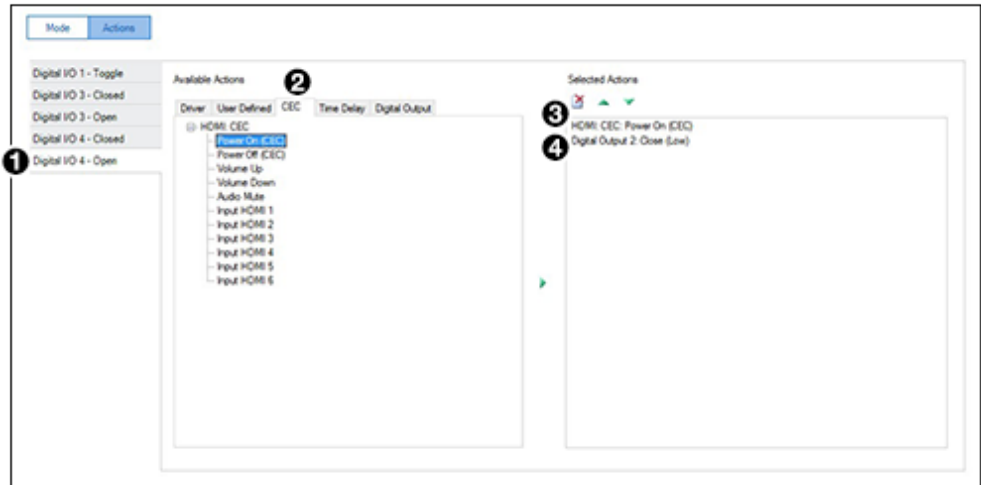

**Figure 34. Adding the Digital Output 2 Open State to the Open State of Digital I/O Port 4**

10. In the Available Actions panel, select the **CEC** tab (2).
11. Drag the **Power On (CEC)** action to the Selected Actions panel on the right (3). This causes the HD CTL 100 to send a display power on command when the timer on the occupancy sensor detects that the room is occupied.

**NOTE:** See the *OCS 100 Setup Guide*, available at [www.extron.com](http://www.extron.com), for setup detail for this sensor.

12. Drag the **Digital Output - Open** command to the Selected Actions panel (4). This causes the LED of the CCR push-button switch to light steadily and keeps the LED status in sync with the display power status.

## Applying the Configuration

After completing configuring the screens for all the desired power on and off actions, do the following to enable the configuration on the HD CTL 100 (see the *HD CTL 100 Configuration Program Help File* for the procedures):

1. Save the configuration as a project.
2. Upload the configuration to your HD CTL 100 unit.

# Reference Information

## Mounting the HD CTL 100

The HD CTL 100 can be set on a table, mounted on a rack shelf, or mounted under a desk, podium, or table.

### ATTENTION:

- Installation and service must be performed by authorized personnel only.
- L'installation et l'entretien doivent être effectués par le personnel autorisé uniquement.

## Tabletop Use

Four self-adhesive rubber feet are included with the HD CTL 100. For tabletop use, attach one foot at each corner on the bottom of the unit, and place the controller where desired.

## Rack Mounting

The HD CTL 100 can be mounted on a 9.5-inch, 6-inch, or 3.5-inch deep rack shelf. They can also be mounted vertically to the front or back rack support. For mounting procedures, see the instructions provided with the mounting kit.

### UL rack mounting guidelines

The following Underwriters Laboratories (UL) guidelines pertain to the safe installation of the equipment in a rack.

- 1. Elevated operating ambient temperature** — If the equipment is installed in a closed or multi-unit rack assembly, the operating ambient temperature of the rack environment may be greater than room ambient temperature. Therefore, install the equipment in an environment compatible with the maximum ambient temperature (TMA = +122 °F, +50 °C) specified by Extron.
- 2. Reduced air flow** — Install the equipment in a rack so that the amount of air flow required for safe operation of the equipment is not compromised.
- 3. Mechanical loading** — When mounting the equipment in the rack, ensure that uneven mechanical loading does not cause a hazardous condition.
- 4. Circuit overloading** — When connecting the equipment to the supply circuit, consider the effect that circuit overloading might have on overcurrent protection and supply wiring. Consider equipment nameplate ratings when addressing this concern.
- 5. Reliable earthing (grounding)** — Maintain reliable grounding of rack-mounted equipment. Pay particular attention to supply connections other than direct connections to the branch circuit (for example, use of power strips).

## Wall or Furniture Mounting

The HD CTL 100 can be mounted on a wall or under a desk, table, or podium using an under-desk mounting kit such as the Extron MBU 125. Mounting kits and instructions are available at [www.extron.com](http://www.extron.com).

**TIP:** Extron recommends wall-mounting the HD CTL 100 behind the display (place the top panel of the unit against the wall), using a mounting kit such as the Extron MBU 125 Under Desk Mounting Brackets (see figure 35).

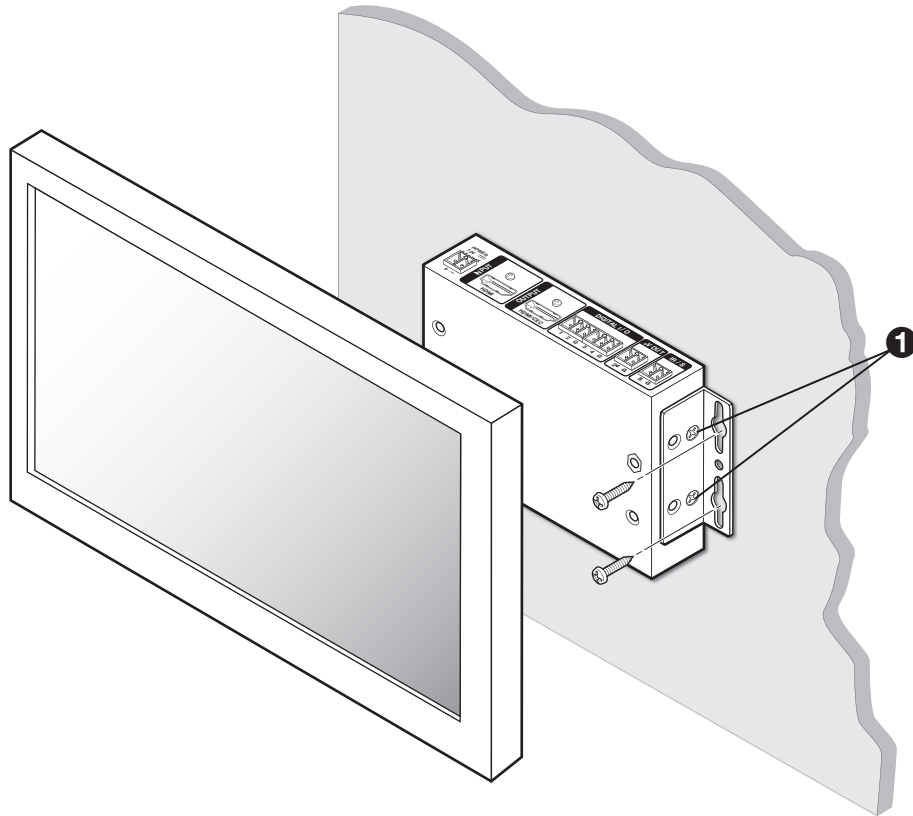

**Figure 35.** Mounting the HD CTL 100 to a Wall behind a Display

**NOTE:** Figure 35 shows the mounting brackets attached to the HD CTL 100 through the bottom two holes in the bracket, closest to the wall (1). If you want to provide space for air flow behind the unit, attach the brackets through the top two holes (farthest from the wall).

## Extron Warranty

Extron Electronics warrants this product against defects in materials and workmanship for a period of three years from the date of purchase. In the event of malfunction during the warranty period attributable directly to faulty workmanship and/or materials, Extron Electronics will, at its option, repair or replace said products or components, to whatever extent it shall deem necessary to restore said product to proper operating condition, provided that it is returned within the warranty period, with proof of purchase and description of malfunction to:

**USA, Canada, South America,  
and Central America:**

Extron Electronics  
1230 South Lewis Street  
Anaheim, CA 92805  
U.S.A.

**Japan:**

Extron Electronics, Japan  
Kyodo Building, 16 Ichibancho  
Chiyoda-ku, Tokyo 102-0082  
Japan

**Europe and Africa:**

Extron Europe  
Hanzeboulevard 10  
3825 PH Amersfoort  
The Netherlands

**China:**

Extron China  
686 Ronghua Road  
Songjiang District  
Shanghai 201611  
China

**Asia:**

Extron Asia Pte Ltd  
135 Joo Seng Road, #04-01  
PM Industrial Bldg.  
Singapore 368363  
Singapore

**Middle East:**

Extron Middle East  
Dubai Airport Free Zone  
F13, PO Box 293666  
United Arab Emirates, Dubai

This Limited Warranty does not apply if the fault has been caused by misuse, improper handling care, electrical or mechanical abuse, abnormal operating conditions, or if modifications were made to the product that were not authorized by Extron.

**NOTE:** If a product is defective, please call Extron and ask for an Application Engineer to receive an RA (Return Authorization) number. This will begin the repair process.

**USA:** 714.491.1500 or 800.633.9876

**Europe:** 31.33.453.4040

**Asia:** 65.6383.4400

**Japan:** 81.3.3511.7655

Units must be returned insured, with shipping charges prepaid. If not insured, you assume the risk of loss or damage during shipment. Returned units must include the serial number and a description of the problem, as well as the name of the person to contact in case there are any questions.

Extron Electronics makes no further warranties either expressed or implied with respect to the product and its quality, performance, merchantability, or fitness for any particular use. In no event will Extron Electronics be liable for direct, indirect, or consequential damages resulting from any defect in this product even if Extron Electronics has been advised of such damage.

Please note that laws vary from state to state and country to country, and that some provisions of this warranty may not apply to you.