

## VM 100 Series • Installation Guide

This guide provides instructions to install a VM 100 Series VESA mounting kit onto a flat panel display to secure Extron products or other devices (such as small form-factor PCs including the Intel® NUC) directly to the display.

The VM 100 K kit consists of two standard components: a VESA mounting plate and a VM 100 P product base plate.

Optional components include:

- VM 100 C cover (shown in step 5) to protect and secure the attached device
- A second VM 100 P product base plate (shown in step 4) that can also be attached to the VESA mounting plate

For a full list of options and included parts, see the [VM Parts List](#) on page 4.

The only tool needed is a Phillips-head screwdriver.

### Installation Steps

#### Step 1 – Attach VESA Mounting Plate to Display

Use four included mounting screws to attach the mounting plate to the flat panel display (see figure at right).

Longer screws and spacers are also included for situations when there is a recessed pocket on the back of the display or if extra clearance is needed.

**NOTE:** Do not overtighten the mounting screws into the flat panel display.

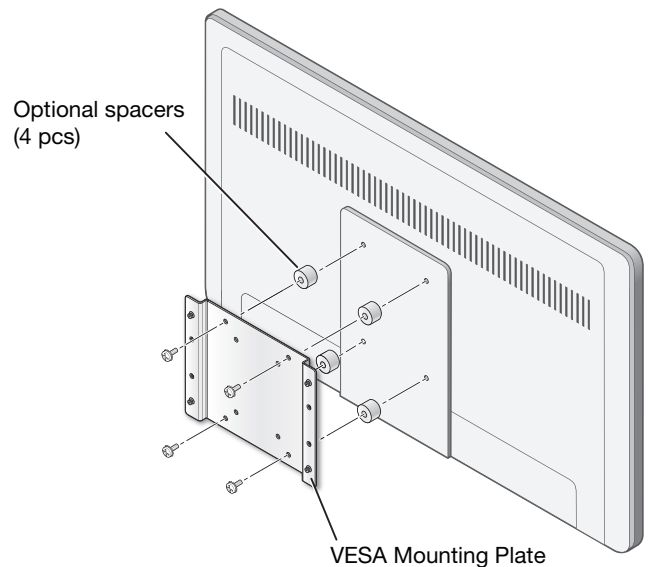

#### Step 2 – Mount the Device to the Product Base Plate

Attach the device to the VM 100 P with the included mounting screws (see figure at right).

**NOTE:** Use the guide lines printed on the base plate to line up your device and the mounting holes (see figure below).

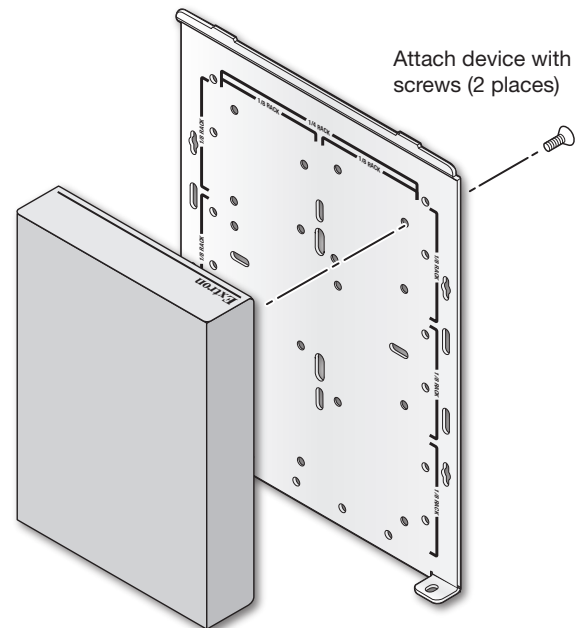
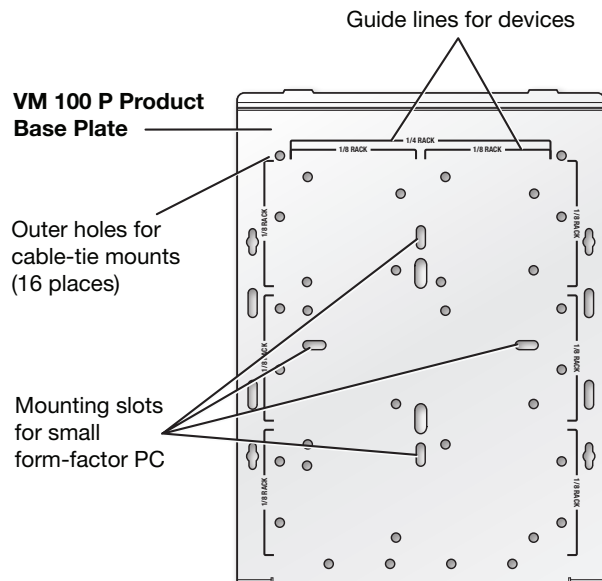

# VM 100 Series • Installation Guide (Continued)

## Step 3 – Route the Wires to the Device

Depending on the device, this step is optional. A smaller device is shown attached to the base plate as an example (see figure at right).

1. Attach the cable-tie mounts to the outer holes on the base plate.
2. Thread cable ties into the mounts and route the wires as appropriate.
3. Trim the cable ties as desired.

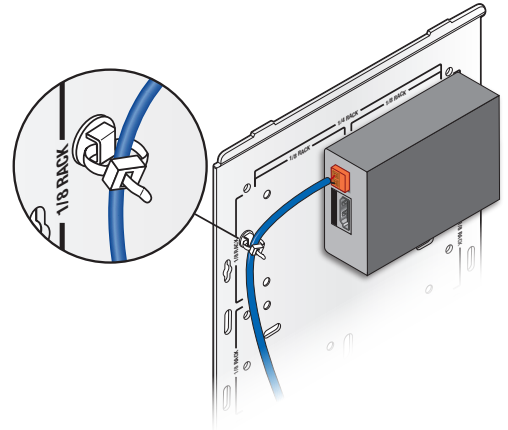

## Step 4 – Attach the Base Plate to the Mounting Plate

1. Attach the VM 100 P product base plate to the VESA mounting plate by sliding the base plate over the shoulder pins on the mounting plate and then sliding the base plate down to anchor the mount (see figure at right).
2. Install the two included pan head screws into the locations noted in the illustration to secure the plates together.

**NOTE:** You have two additional options to mount your devices using the VM 100 P (see below and the next page, and refer to the [VM Parts List](#) on page 4).

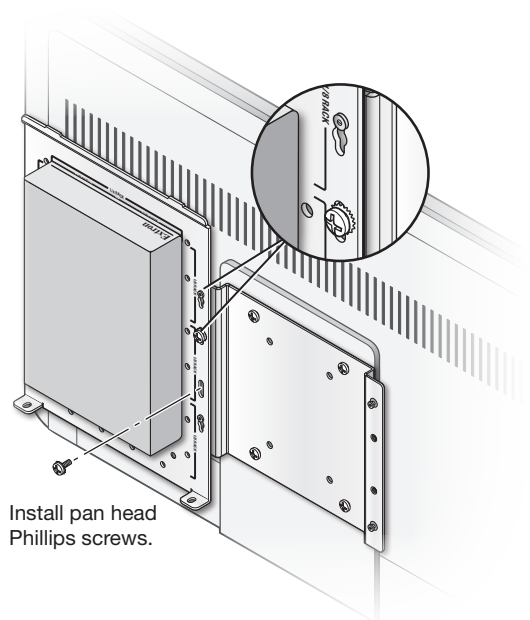

## Adding a second VM 100 P:

A second (optional) VM 100 P with attached devices can be mounted to the open side of the VESA mounting plate (see figure at right).

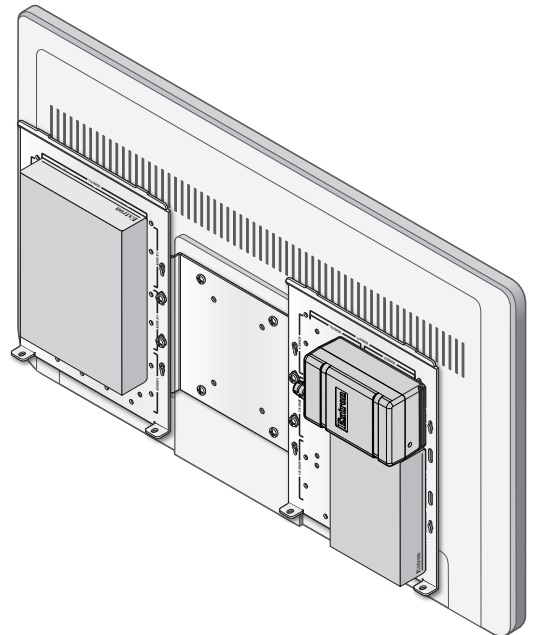

### Mounting the Base Plate Centered on the Mounting Plate:

The VM 100 P base plate with attached devices can also be mounted directly over the VESA mounting plate (see figure at right).

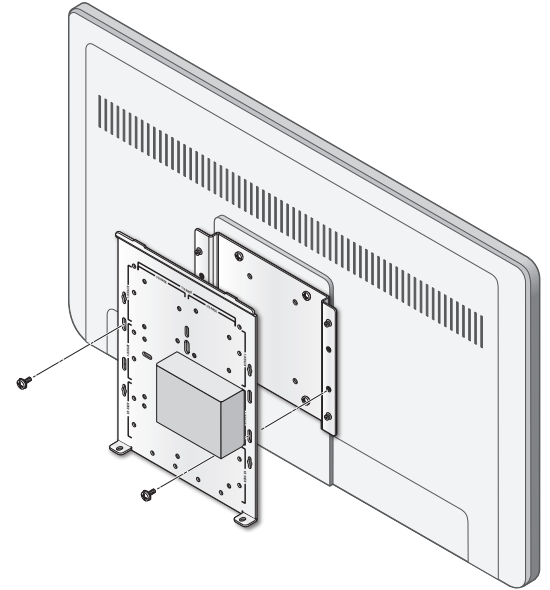







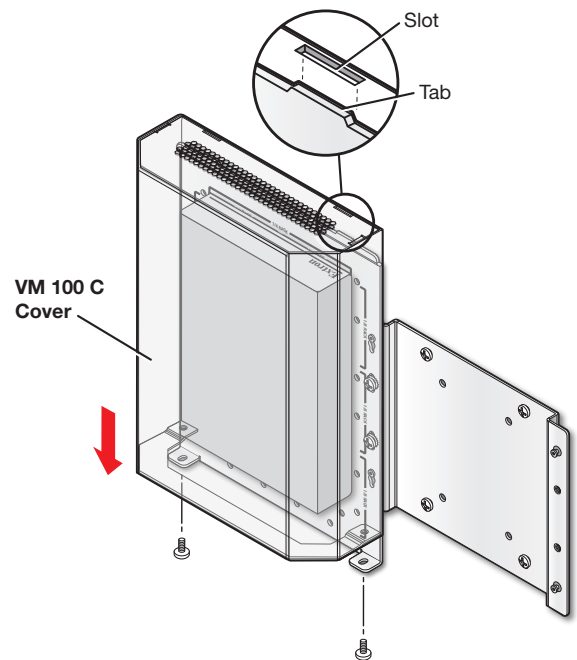

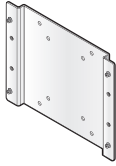
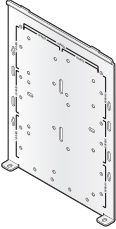
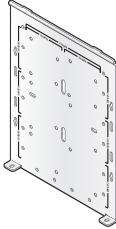
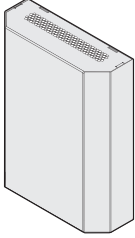

### Step 5 – Install the Cover Over the Device

This next step installs the optional VM 100 C cover (see figure at right).

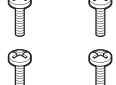
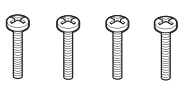
1. Align the slot on the VM 100 C with the tab on the VM 100 P product base plate.
2. Slide the VM 100 C down until the tabs seat.
3. Use the included screws to fasten the bottom of the cover to the base plate.

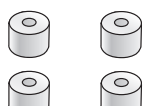

## VM Parts List

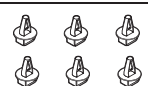
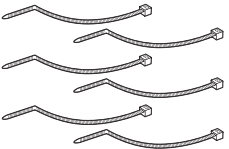
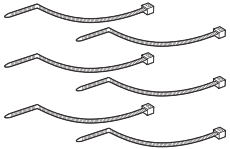
	VM 100 K	VM 100 P	VM 100 C
VESA Mounting Plate			
Product Base Plate			
Cover			
#4-40 x 3/16 Product Mounting Screws			
M4 x 8 mm VESA Screws			
M4 x 15 mm VESA Screws			
M4 x 25 mm VESA Screws			
#6-32 x 3/8 Panhead Screws			
3/8" Spacer			
Cable-tie Mounts			
Cable zip-tie			

For information on safety guidelines, regulatory compliances, EMI/EMF compatibility, accessibility, and related topics, see the [Extron Safety and Regulatory Compliance Guide](#) on the Extron website.