

DMP 128 FlexPlus

ProDSP DANTE DIGITAL MATRIX PROCESSORS



VoIP



The DMP 128 FlexPlus is a powerful, flexible audio DSP processor that is ideal for systems with multiple Dante sources. It features 48x24 Dante connectivity, 12 FlexInput channels with AEC for Dante microphone arrays, and an extensive mix matrix. With flexible connectivity via a USB audio interface and optional VoIP, plus a 16x16 expansion port and ACP Series control compatibility, these new audio processors bring full rack performance into a half rack space.

- ▶ 60 total inputs and 32 total outputs
- ▶ 48x24 Dante audio networking with Dante Domain Manager and AES67 support
- ▶ Twelve channels of AEC - Acoustic Echo Cancellation
- ▶ Both models include a USB Audio interface, providing a total of up to four channels of digital audio sends and returns
- ▶ V model includes up to eight VoIP lines that support generic Session Initiation Protocol - SIP 2.0
- ▶ Compact half rack size

Extron

DESCRIPTION

The **DMP 128 FlexPlus** Series of compact Dante Digital Matrix Processors features twelve FlexInput channels with full DSP, including AEC, and Dante connectivity, in only a half rack space. With an extensive mix matrix, a USB audio interface, and analog compatibility, the DMP 128 FlexPlus provides the ability to easily connect and route multiple types of source signals to accommodate diverse analog and digital system requirements. For collaboration applications, the V model includes up to eight VoIP lines. Featuring an ACP bus for audio control panels, an expansion port for bidirectional digital audio connection with a DTP CrossPoint or another DMP, eight audio file players, and configurable macros, the DMP 128 FlexPlus can be used anywhere from a collaboration space, to a large conference room.

FlexPlus - Ideal for Multiple Dante Sources

The Dante-enabled DMP 128 FlexPlus Series is ideal for applications that utilize Dante ceiling microphone arrays and other Dante-enabled devices. With network connectivity for up to 48 Dante sources and 24 Dante destinations, the DMP 128 FlexPlus, featuring a built-in two-port Gigabit switch, enables the creation of simplified, cost effective audio systems.

FlexInputs

All twelve main DSP channels of the DMP 128 FlexPlus offer FlexInput source selection to route any Dante input, expansion input, or one of the four mic/line inputs, to a main DSP channel. This enables the DMP 128 FlexPlus to process audio from any source with the full range of DSP capabilities, including AEC.

Dante Connectivity

The DMP 128 FlexPlus provides scalable Dante digital audio transport, with Dante Domain Manager support, over a local area network using standard network protocols. A DMP 128 FlexPlus can be configured to support primary and redundant Dante audio networks, as well as AES67 interoperability.

Acoustic Echo Cancellation

The DMP 128 FlexPlus Series includes Extron AEC for conferencing applications. AEC is essential for effective remote room-to-room conversations, ensuring clear, natural communication for all participants. These models include twelve independent channels of high performance AEC, as well as selectable noise cancellation. AEC processing can be challenged by conditions such as double-talk, when talkers from both ends are speaking simultaneously, and when near end talkers use wireless microphones. Extron AEC features advanced algorithms that deliver fast echo canceler convergence for optimal intelligibility, even in challenging conditions.

VoIP - Voice over Internet Protocol Capability

The DMP 128 FlexPlus C V AT includes up to eight SIP 2.0 VoIP lines, with wideband codec support, that can be configured as individual extensions or with multiple call appearance channels to support local conferencing applications. Compatible with select VoIP systems, the V model of the DMP 128 FlexPlus Series can be used for a single VoIP line or as a VoIP farm for up to eight rooms.

KEY FEATURES

- ▶ **60 total inputs and 32 total outputs** – The DMP 128 FlexPlus offers signal routing and management for a wide range of sound system applications:
 - Inputs:** 48 Digital via Dante or Expansion Bus, 4 Analog balanced/unbalanced mic/line level, 8 Aux for USB, VoIP, or file players
 - Outputs:** 16 Digital via Dante or Expansion Bus, 8 Analog balanced/unbalanced line level, 8 Aux for USB, VoIP or File Players
- ▶ **48x24 Dante audio networking with Dante Domain Manager and AES67 support** – Dante audio networking provides scalability for creating larger audio matrixes over a local area network using standard protocols. A built-in two-port Gigabit switch can be configured to support primary and redundant Dante audio networks.
- ▶ **Twelve channels of AEC - acoustic echo cancellation** – The DMP 128 FlexPlus includes twelve independent channels of high performance AEC, as well as selectable noise cancellation. Extron AEC features advanced algorithms that deliver fast echo canceler convergence for optimal intelligibility in situations that challenge AEC performance.
- ▶ **All models include a USB Audio interface, providing up to four channels of digital audio sends and returns** – Support for USB Audio simplifies implementation of systems with either soft-codec conferencing or computer-based audio and enables use of the same interface for both small and large scale systems.
- ▶ **V model includes up to eight VoIP lines that support generic Session Initiation Protocol - SIP 2.0 connectivity per RFC 3261** – The DMP FlexPlus C V AT is compatible with select VoIP systems and can be used for a single VoIP line or as a VoIP farm for up to eight rooms.
- ▶ **Compact half rack size** – Allows more input and output channels, with more processing power, to be installed in less space.
- ▶ **FlexInput capability on main inputs** – All twelve main inputs offer FlexInput capability to select a Dante channel, expansion input, or one of the four mic/line inputs. This allows incorporating the full range of DSP capabilities, including AEC, for incoming Dante channels.
- ▶ **Optional ACP Series audio control panels provide intuitive audio system control** – Direct connection to the DMP 128 FlexPlus offers flexible audio control for systems that do not require a full control system.
- ▶ **Digital I/O ports for remote control or feedback** – Two digital input ports and two digital output ports are provided, so that the DMP 128 FlexPlus can be programmed to sense and then respond to external triggers such as mic activation, muting, and recall of presets.
- ▶ **Macros allow the sequencing of commands that can be sent to the local device or external devices via the LAN port** – A single DMP 128 FlexPlus can act as the central interface from a control system, sending commands to other DMP, AXI AT, and DTP CrossPoint devices.

OVERVIEW

Twelve FlexInput Channels

With full DSP, including AEC, filters, dynamics, automixing, delay, and ducking

Compact Half Rack Size

Requires less rack space or easily fits under a table

60x32 Total Inputs and Outputs

Via Dante, expansion bus, analog, USB, and VoIP

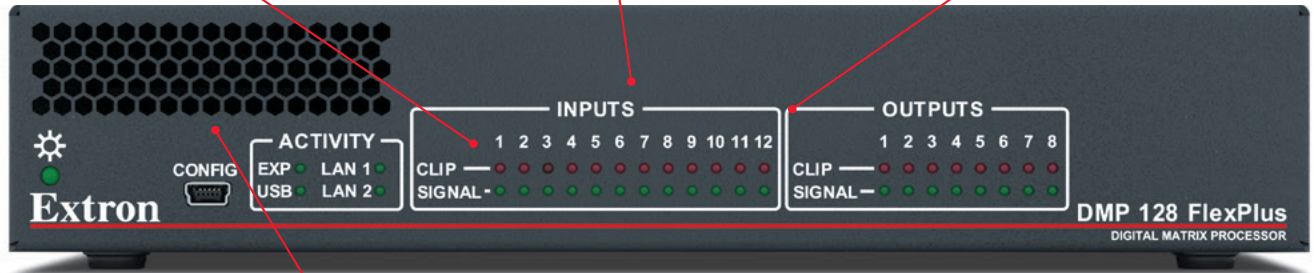

DMP 128 FlexPlus C V AT - Front

Front to Back Ventilation

Allows side by side and above or below rack mounting of other devices

Digital I/O Ports

Provides for external triggering such as microphone activation and muting

Analog Audio Connectivity

Four inputs and eight outputs for connection to legacy analog devices

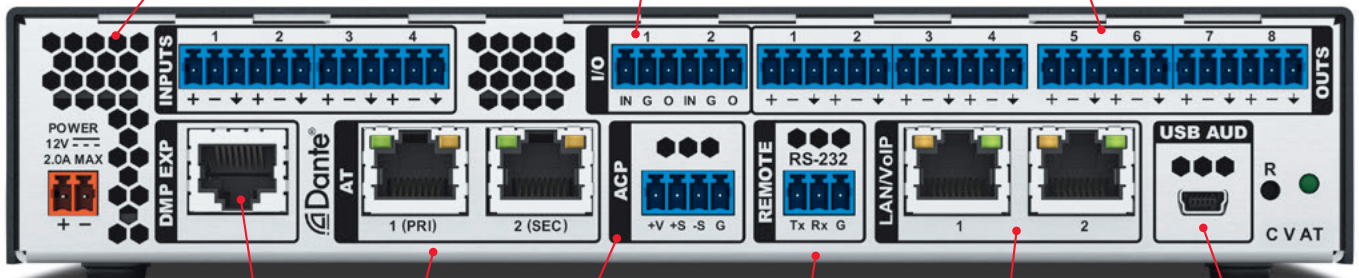

DMP 128 FlexPlus C V AT - Back

Expansion Port

Provides a bidirectional digital audio connection with another DMP or a DTP CrossPoint

ACP Bus

Connects to the ACP Series of audio control panels to provide control of volume and preset/macro recall

VoIP Support

Up to eight VoIP lines that support generic Session Initiation Protocol - SIP 2.0

USB Audio Interface

Provides digital connection to a soft conferencing codec or computer based audio recording/playback

48x24 Dante Audio Networking

Includes Dante Domain Manager and AES67 support

Control System Connectivity

Externally control DSP functions via RS-232 or network connection

PANEL DRAWINGS

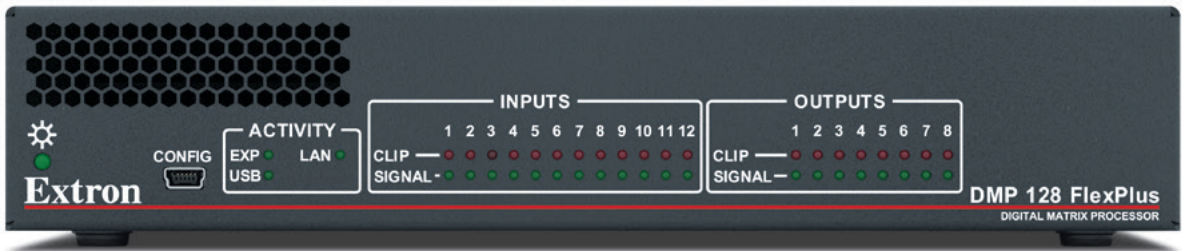

DMP 128 FlexPlus CAT - Front

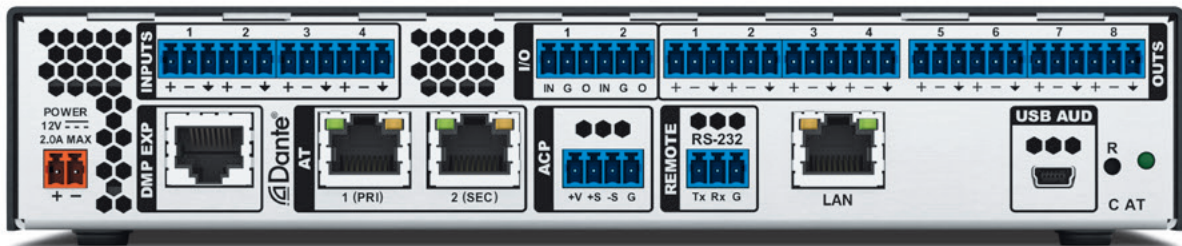

DMP 128 FlexPlus CAT - Back

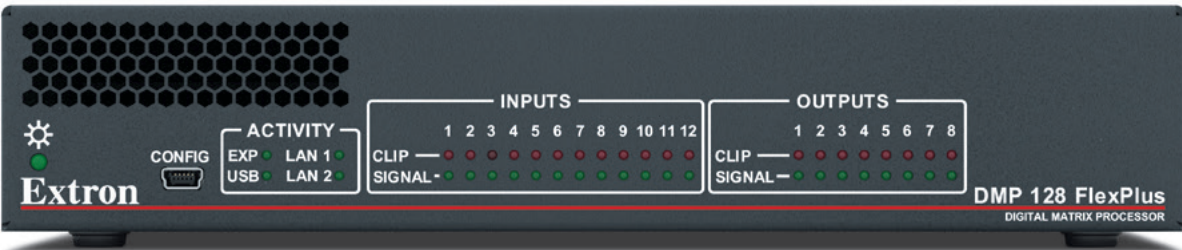

DMP 128 FlexPlus C V AT - Front

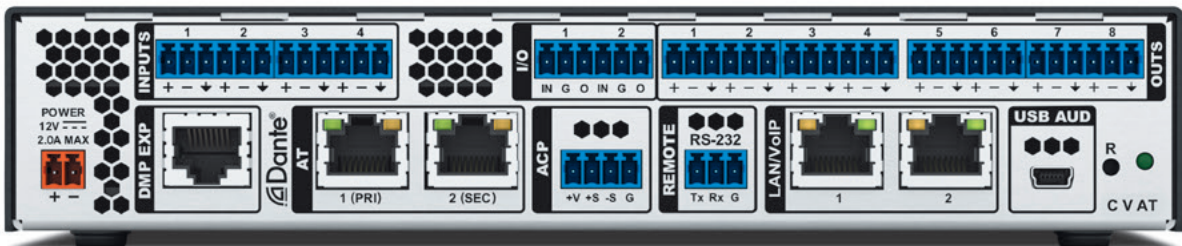

DMP 128 FlexPlus C V AT - Back

SPECIFICATIONS

AUDIO SYSTEM	
Gain	Balanced output: 0 dB, unbalanced output: -6 dB
Frequency response	20 Hz to 20 kHz, ± 0.2 dB
THD + Noise	<0.01%, 20 Hz to 20 kHz, at maximum level
S/N	
Analog In to Analog Out	>107 dB, 20 Hz to 20 kHz, at maximum balanced output (unweighted)
Analog In to Digital Out	110 dB, 20 Hz to 20 kHz, at full-scale output (unweighted)
Digital In to Analog Out	115 dB, 20 Hz to 20 kHz, at maximum balanced output (unweighted)
Crosstalk	<-90 dB @ 20 Hz to 20 kHz, fully loaded
AUDIO INPUT	
Number/signal type	4 mono (or 2 stereo), mic/line, balanced/unbalanced, 4 with phantom power
Connectors	(2) 3.5 mm captive screw, 6 pole, mono, balanced/unbalanced
Impedance	>10k ohms balanced/unbalanced
Nominal level	-60 dBV, +4 dBu, -10 dBV adjustable via input gain
Maximum level	+21 dBu at rated THD+N when mic gain is set to 0 dB
CMRR	>60 dB typical
DC phantom power	+48 VDC, $\pm 10\%$ (inputs 1-4) can be switched on or off per input
AUDIO OUTPUT	
Number/signal type	8 mono (or 4 stereo), line, balanced/unbalanced
Connectors	(4) 3.5 mm captive screw, 6 pole, mono, balanced/unbalanced
Impedance	100 ohms balanced, 50 ohms unbalanced
Gain error	± 0.1 dB channel to channel
Maximum level (Hi-Z)	>+21 dBu balanced, >+15 dBu unbalanced
AUDIO PROCESSING	
A/D, D/A conversion	24-bit, 48 kHz
AEC tail length	>200 msec
AEC convergence	Up to 60 dB/sec
Noise cancellation	Up to 20 dB, software selectable
EXP PORT	
Transmission type	Proprietary
Connector	1 RJ-45
Inputs	16 channels Rx
Outputs	16 channels Tx
Audio format	Uncompressed, 24-bit, 48 kHz
EXP cable	Shielded CAT6 up to 10 meters (1 foot cable included)
USB AUDIO PORT	
Connector	1 rear panel USB mini-B
USB standards	USB 2.0, high speed
AT PORTS – AUDIO TRANSPORT	
Transmission	Dante/AES-67, software selectable
Connectors	2 RJ-45, 2-port 1 Gbps switch to Dante interface
Inputs	48 channels Rx
Outputs	24 channels Tx
Audio format	Uncompressed, 24-bit, 48 kHz
Latency	Deterministic, based on user selections: 0.25 ms, 0.5 ms, 1.0 ms (default), 2.0 ms, 5.0 ms
VOIP PORT(S)	
Connector	1 RJ-45
Data rate	10/100/1000 Base-T
Signaling protocol	Session Initiation Protocol (SIP), RFC 3261 and related RFCs
Discovery protocol	LLDP-MED (optional)

Lines	Up to 8 concurrent, independent extensions	
Codec support	Various ITU, including wideband	
Default settings	Link speed and duplex level = autodetected IP address = 192.168.1.254 Subnet mask = 255.255.255.0 Default gateway = 0.0.0.0 DHCP = off	
CONTROL/REMOTE		
Serial host control port	1 bidirectional RS-232, 3.5 mm captive screw, 3 pole	
Baud rate and protocol	38400 baud, 8 data bits, 1 stop bit, no parity	
USB control port	1 front panel USB mini-B	
ACP control port	(1) 3.5 mm captive screw, 4 pole, supports up to 8 panels	
Pin configuration	1 = +12V, 2 = +S, 3 = -S, 4 = G	
Power supply	6 Watts max	
Digital I/O	(2) 3.5 mm captive screw, 3 pole	
Pin configuration	1 = In, 2 = G, 3 = Out 1	
Voltage range	Input = 0V to +12V Output = 0V (low), 5V (high) Software programmable	
Ethernet host port	1 RJ-45	
Data rate	10/100/1000 Base-T	
Protocol	ARP, ICMP, IP, TCP, DHCP, HTTPS, Telnet, SSH	
Web server	Up to 200 simultaneous sessions	
Program control	Extron DSP Configurator control/configuration program for Windows® Extron Simple Instruction Set (SIS™) Microsoft® Internet Explorer®, Telnet	
GENERAL		
Power supply	External Input: 100-240 VAC, 50-60 Hz Output: 12 VDC, 2 A, 24 watts	
Power consumption		
DMP 128 FlexPlus C AT		
Device	14.9 watts	
Device and power supply	17.1 watts	
DMP 128 FlexPlus C V AT		
Device	15.6 watts	
Device and power supply	17.9 watts	
Thermal dissipation		
DMP 128 FlexPlus C AT		
Device	40.6 BTU/hr	
Device and power supply	48.0 BTU/hr	
DMP 128 FlexPlus C V AT		
Device	43.1 BTU/hr	
Device and power supply	50.8 BTU/hr	
Cooling	Fan, front to back, variable speed, OFF when ambient temperature is less than 45°C	
Mounting		
Rack mount	Yes, with optional 1U rack shelf	
Furniture mount	Yes, with optional under-desk mounting kit	
Enclosure dimensions	1.7" H x 8.7" W x 9.5" D (1U high, half rack wide) (4.3 cm H x 22.1 cm W x 24.1 cm D)	
Product weight	2.4 lbs (1.1 kg)	
Regulatory compliance	CE, c-UL, UL, CE, C-Tick, FCC Class A, ICES, RoHS, VCCI, WEEE	
Warranty	3 years parts and labor	
NOTE: All nominal levels are at $\pm 10\%$.		
Model	Version Description	Part number
DMP 128 FlexPlus C AT	Dante Digital Matrix Processor w/ 12 AEC	60-1820-10
DMP 128 FlexPlus C V AT	Dante Digital Matrix Processor w/ 12 AEC and VoIP	60-1821-10

For complete specifications, please go to www.extron.com
Specifications are subject to change without notice.

APPLICATION DIAGRAM

Conference Room with Dante Microphone Array and VoIP

In this fully loaded flexible conference room, audio processing is handled by the DMP 128 FlexPlus C V AT while AV matrix switching is performed by a DTP CrossPoint. Twelve microphone channels from an eight-channel ceiling mic array and four desktop mics are connected via Dante to the DMP 128 Flex Plus C V AT, where they receive all processing necessary for conferencing, including AEC on all twelve channels. Depending on need, the user can switch between a soft conferencing codec and a dedicated VoIP server. The entire system is network controlled from an Extron TLP Pro 1025T Touchpanel working in concert with the IPCP control processor embedded in the DTP CrossPoint 4K Matrix Switcher. High performance mix minus audio playback is provided by the eight-channel, half rack XPA U 358 power amplifier directly feeding SF 26CT two-way ceiling speakers.

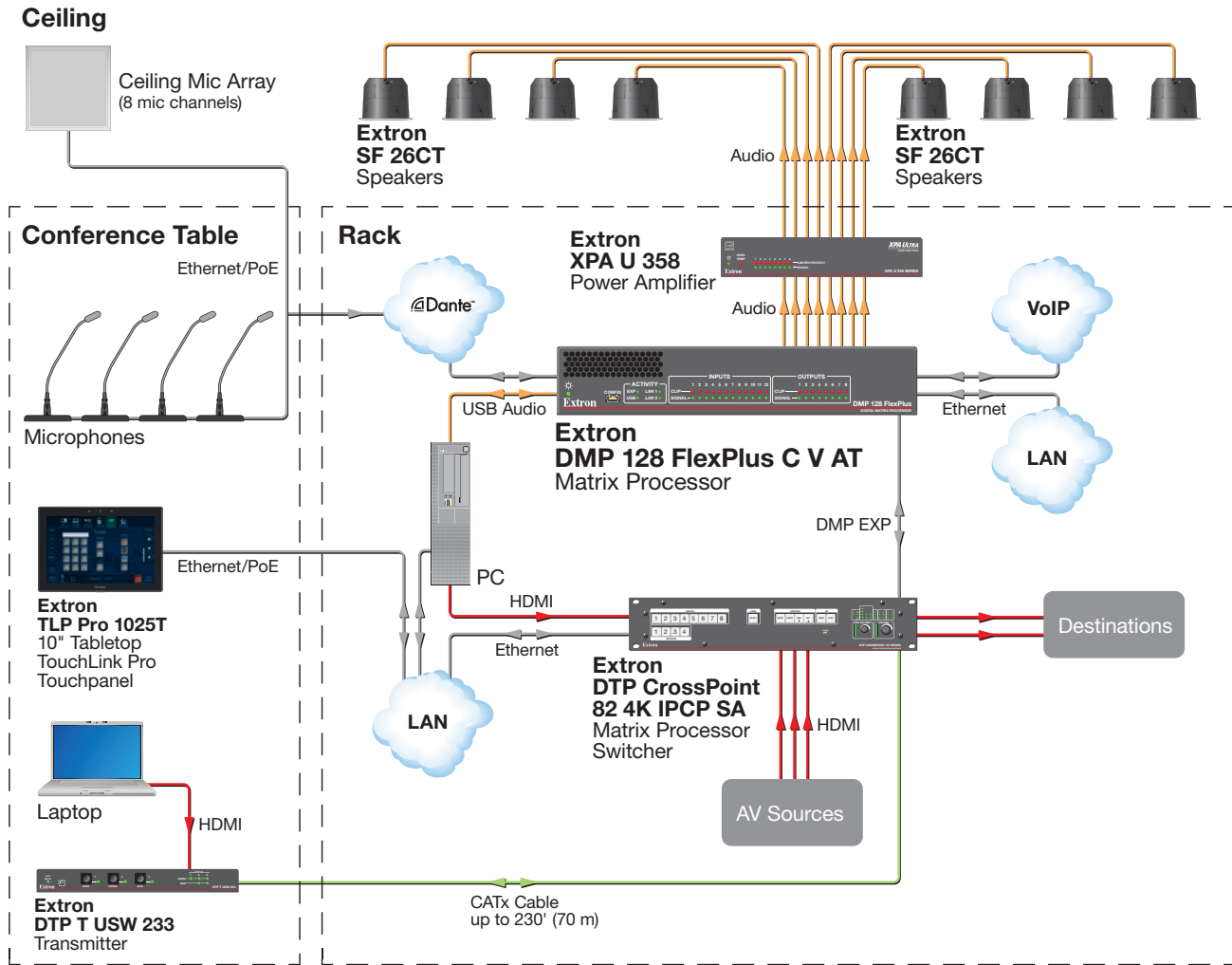

WORLDWIDE SALES OFFICES

Anaheim • Raleigh • Silicon Valley • Dallas • New York • Washington, DC • Toronto • Mexico City • Paris • London
 Frankfurt • Madrid • Stockholm • Amersfoort • Moscow • Dubai • Johannesburg • Tel Aviv • Sydney • Melbourne
 Bangalore • Mumbai • New Delhi • Singapore • Seoul • Shanghai • Beijing • Hong Kong • Tokyo

www.extron.com