

DMP 128 Series

12x8 ProDSP™ DIGITAL MATRIX PROCESSORS

ProDSP

Advanced Audio DSP with Quick and Intuitive Configuration

- ▶ 3 models with 12 mic/line inputs and 8 outputs
- ▶ Models available with:
 - AEC - acoustic echo cancellation
 - Dante™ audio networking
 - POTS - analog telephone interface
- ▶ ProDSP audio signal processing:
 - 64-bit floating point digital signal processing engine
 - Fixed, low latency DSP processing
- ▶ Digital audio expansion port
- ▶ Automixer with eight groups
- ▶ DSP Configurator™ Software for fast configuration

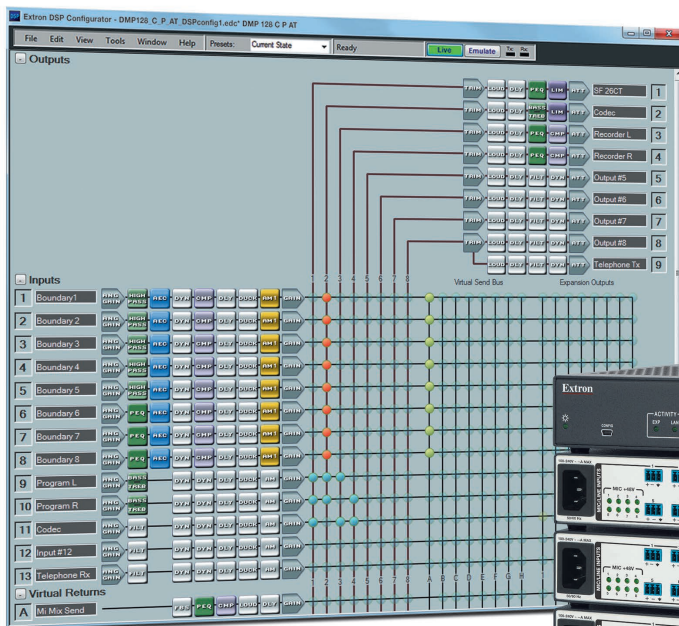

Extron® Electronics
INTERFACING, SWITCHING AND CONTROL

Introduction

The Extron **DMP 128** Digital Matrix Processor is a 12x8 audio mixer featuring Extron ProDSP, automixing, and available AEC plus Dante™ audio networking and POTS analog phone interfacing. The DMP 128 Series offers a configuration approach to DSP that simplifies mixing, routing, conferencing, and room optimization. Quick and intuitive configuration using the **DSP Configurator Software** allows the DMP 128 to be installed in very little time, with easy-to-learn adjustments that can be heard in real-time. A digital audio expansion port allows two DMP 128 units to be linked together to expand input and output signal management and routing capabilities. The DMP 128 is ideal for presentation and conferencing applications in boardrooms, courtrooms, and conference centers.

ProDSP

ProDSP is engineered from the ground up using a powerful 64-bit floating point DSP engine to provide very wide dynamic range, plus studio grade 24-bit audio converters with 48 kHz sampling. ProDSP is loaded with powerful, easy-to-configure tools to control level, dynamics, filters, delay, ducking, loudness, and feedback suppression.

Flexible Routing Within the DMP 128

The DMP 128 features 12 mono mic/line inputs, eight with phantom power. These inputs can be matrix mixed into any of the eight output buses to create finely tuned audio zones for the corresponding outputs. In addition, the 12 inputs can be routed to any of the eight “virtual” buses to allow inputs to be processed together as a group, before routing back into the output buses. The DMP 128 C P AT includes FlexInputs to provide the additional capability of processing Dante channels from remote wireless microphones, wallplates, and other sources anywhere on the Dante network, in place of local mic/line inputs 1 - 8. This allows incorporating the full range of DSP processing capabilities, including AEC, for incoming Dante channels.

Expanded Routing Across Two DMP 128 Processors

An expansion port allows two DMP 128 models to be linked together via a single shielded CAT 6 cable. This allows eight matrix mixes of the inputs, plus eight virtual paths to be sent and received between units, for a total of 16 incoming and 16 outgoing buses. Each bus carries 24-bit/48 kHz high-resolution digital audio.

Automixer

The DMP 128 features an automixer with gated and gain sharing modes for managing up to eight groups of microphone signals. Gating threshold, signal level reduction, and timing parameters are user-adjustable per channel. This allows for fine-tuning to avoid the “chopped” sound characteristic of a traditional automixer when a mic is gated off.

Acoustic Echo Cancellation

The two DMP 128 C models include Extron AEC for conferencing applications. AEC is essential for effective remote room-to-room conversations, ensuring clear, natural communication for all participants. These models include eight independent channels of high performance AEC, as well as selectable noise cancellation. Extron AEC features advanced algorithms that deliver fast echo canceler convergence for optimal intelligibility, even in challenging conditions such as double-talk and the use of wireless microphones.

Dante Audio Networking

Dante-equipped DMP 128 AT models provide scalable audio transport over a local area network using standard Internet protocols. DMP 128 C P AT sends out 24 channels of digital audio and can receive 56 channels over the network. A built-in four-port Gigabit switch also provides direct interconnection of multiple DMP 128 AT processors, AXP 50 C AT, AXP 64 C AT expansion processors, AXI 22 AT D, AXI 22 AT, AXI 44 AT expansion interfaces, and NetPA amplifiers to create larger, cost-effective audio matrixes.





The **DMP 128** features Extron ProDSP, a powerful digital signal processing platform based on a 64-bit floating point DSP engine. ProDSP provides an extensive array of digital processing tools for audio system design, configuration, and optimization. The DSP Configurator Software is the user interface to ProDSP for full control and management of the DMP 128 and all of its DSP functions, including gain, dynamics, filtering, delay, ducking, loudness, and feedback suppression. DSP Configurator Software is also used to configure and manage AEC and automixing.

An integral part of the DSP Configurator Software is the Graphical User Environment, which allows for quick and easy visualization of all signal paths inside a single window. Working within this user-friendly environment, an audio system designer or installer can clearly view and adjust all input levels, audio DSP processing parameters, mixing points, and output levels. To simplify these adjustments, SpeedNav keyboard navigation ensures efficient and fast navigation through the Graphical User Environment, using just the keyboard on a laptop.

Highest Quality Converters Plus Floating Point DSP

The DMP 128 features studio grade ADCs - analog-to-digital converters and DACs - digital-to-analog converters using professional level 24-bit resolution and 48 kHz sampling, fully preserving the integrity of the original audio signal.

The processing power of the 64-bit floating point DSP engine allows for simultaneous audio processing algorithms within the same channel, and across multiple channels, without compromising sound quality. Throughput latency – the normal delay of audio signals due to audio processing – is deterministic, with very low overall latency regardless of the number of channels and processes, so that audio is kept in sync with video. This powerful DSP engine also delivers very wide dynamic range to prevent clipping and fully maintain signal quality.

Fixed Yet Flexible DSP Architecture

The DSP Configurator Software features a fixed layout of DSP processing blocks for each input, output, and virtual bus. Each block in the Graphical User Environment represents a Gain, Dynamics, Delay, Filter, Ducking, or FBS - Feedback Suppression algorithm within the DSP engine. While this architecture is fixed, each block offers flexible options and customizable parameters. For example, the Filter block contains several selectable filters, each of which can be customized as high pass, low pass, bass and treble or parametric EQ. Each processing block can be selectively bypassed.

Emulate and Live Modes

The DSP Configurator Software features an Emulate mode, which provides complete audio system design while working offline on a PC. When connected to the DMP 128, Live mode enables real-time control of all settings, file updates, and archiving, plus active metering of all input and output channels. In Live mode, integrators can “push” all or part of a configuration to the DMP 128 from the PC, while preserving the existing file. Emulate and Live modes give audio system designers the flexibility to create an entire project from their PC in advance of installation, and then, once they are on-site, use the same software to provide accurate system setup and final optimization.

EXTENSIVE ARRAY OF DSP TOOLS

AEC	8 independent acoustic echo cancellers with selectable noise reduction, available on the 2 DMP 128 C models
GAIN STAGES	4 gain stages across inputs to outputs Gain control at mix points
DYNAMICS	AGC - automatic gain control Compressor Limiter Noise gate
AUTOMIXING	8 groups for any input and incoming expansion bus
DUCKING	1 ducking processor per input with multiple priority levels
LOUDNESS	1 loudness processor per virtual bus and per output
FILTERS	5 filters per input, 3 filters per virtual bus, 9 filters per output; all filters are selectable and customizable High pass Low pass Bass and treble shelving Parametric EQ
DELAY	Up to 200 ms; available on all inputs, outputs, and virtual buses
FEEDBACK SUPPRESSION	Anti-feedback processor for first four virtual buses
PRESETS	32 presets store entire DSP configurations or selected DSP settings

Extron ProDSP includes all the essential DSP tools needed to set up and fine-tune audio systems. These tools, or processing blocks, allow for control and management of gain, dynamics, filtering, delay, ducking, and feedback suppression. Selecting any of these blocks opens a dedicated pop-up window with a range of options and customizable parameters. Multiple windows can be opened at the same time. Input and output levels can be monitored at any time by simply opening any of the input or output Gain or Attenuation windows.

Key Features

DIGITAL AUDIO EXPANSION PORT

An expansion port allows two DMP 128 models to be linked together via a single shielded CAT 6 cable. The cable transports 16 incoming and 16 outgoing expansion buses between the processors, allowing individual inputs, matrix mixes of inputs, or virtual paths to be sent to the connected unit. Each bus carries 24-bit/48 kHz high resolution digital audio within the DMP 128. Designers can use this expanded 16x16 I/O channel transport to create audio mixes with advanced I/O and signal management scenarios combining the capabilities of two DMP 128 processors. The expansion port is also available on Extron DTP CrossPoint® matrix switchers. This allows an 8x16 I/O channel transport between the matrix switcher and the DMP 128 to expand the number of available audio inputs for a DTP System, and to offer additional capabilities such as automixing, AEC, and POTS analog phone interfacing with DMP 128 C P models.

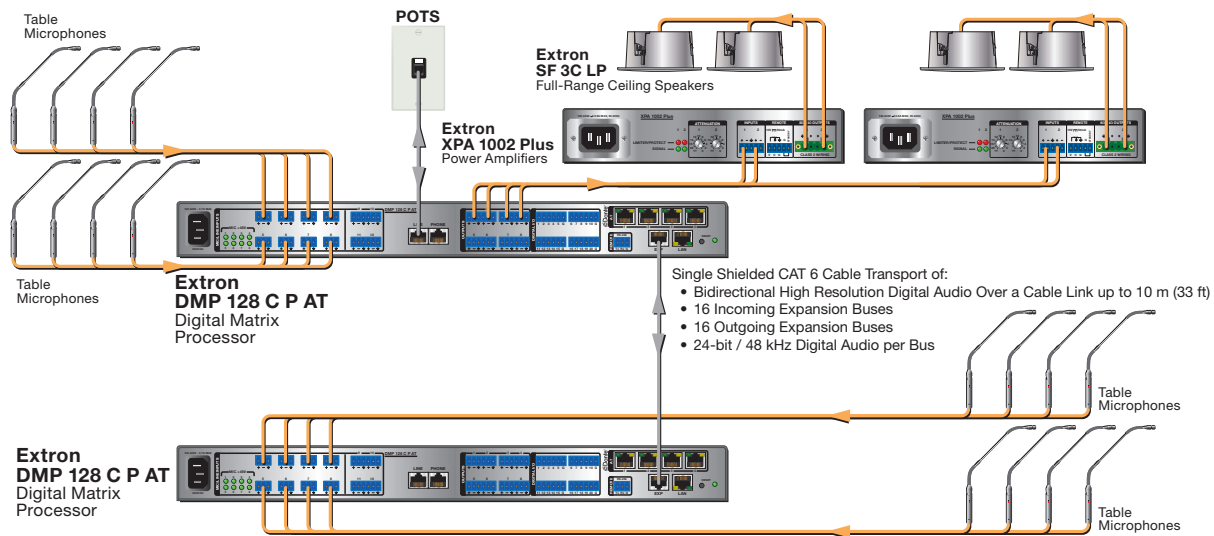

AUTOMIXER

The DMP 128 offers an automixer with gated and gain sharing modes, and includes several advanced features for optimizing microphone management. Multiple trigger protection allows only the microphone with the highest signal to be active while the rest are gated off. The NOM - number of open microphones can be specified to limit the number of active microphones at one time. For a natural sounding mic mix, the automixer also offers a gain sharing mode when the NOM is bypassed, allowing all mics to gate on. A global automixer configuration screen in the DSP Configurator Software enables fast, intuitive management of all microphones and groups in a centralized user interface.

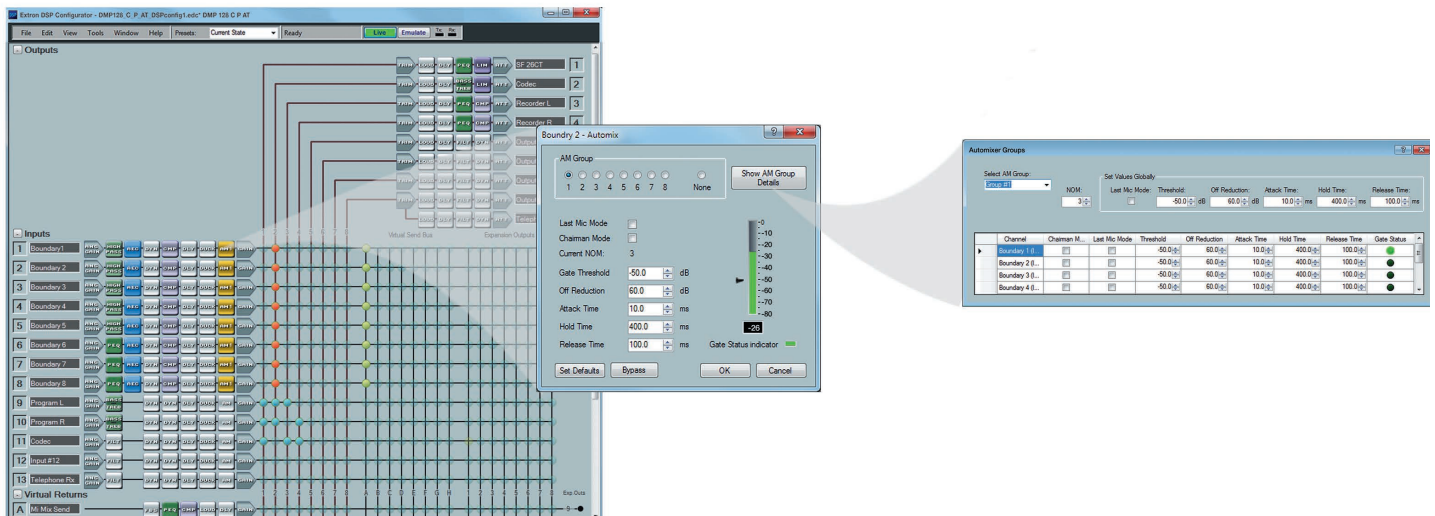

ACOUSTIC ECHO CANCELLATION

In conferencing applications, hearing the talker's voice returned as an echo is disruptive to natural communication. AEC processing prevents far end audio, as reproduced in the near end, from being returned back to the remote talker as echo, ensuring clear, natural conversations. However, AEC processing can be challenged by conditions such as double-talk, when talkers from both ends are speaking simultaneously, and when near end talkers use wireless microphones. Extron AEC delivers fast echo cancelling optimized for these challenging conditions.

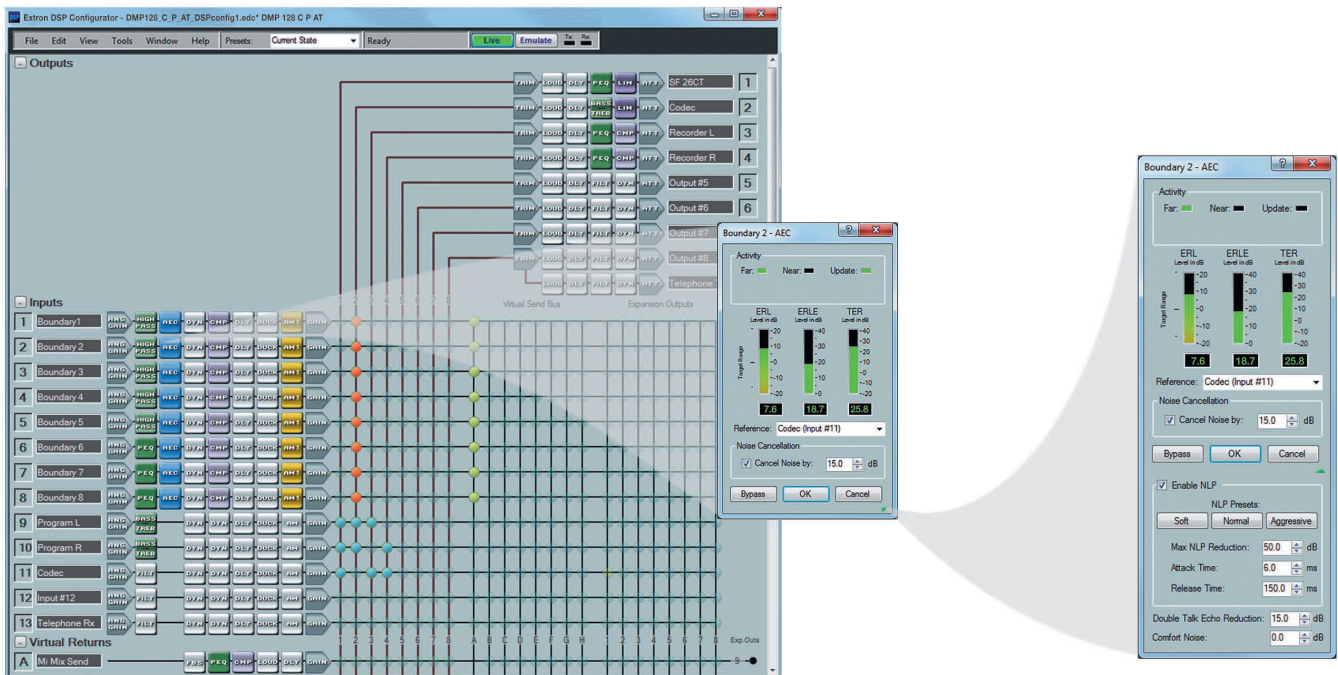

The DSP Configurator Software simplifies AEC and noise cancellation setup with a user-friendly interface that provides real-time metering for ERL - echo return loss, ERLE - echo return loss enhancement, and TER - total echo reduction levels. Guided alerts appear whenever ERL is outside of the optimal range for echo cancellation. Optional settings include fine adjustments for NLP - non-linear processing to maximize AEC performance in acoustic environments with significant sonic reflections or reverberation.

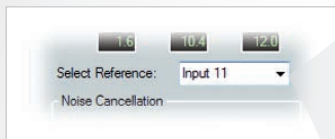

AEC Dialog Close-Up

An AEC reference can be individually selected for each of the eight independent AEC processors within the two DMP 128 C models.

- Output 1
- Output 2
- Output 3
- .
- .
- Output 8
- Input 1
- Input 2
- Input 3
- .
- .
- Input 12
- Virtual A
- Virtual B
- Virtual C
- .
- .
- Virtual H

Selecting the AEC Reference

Audio from the far end is reproduced by near end loudspeakers so that listeners can hear the far end talkers. However, this audio can return to the far end via the near end mics, DSP, and codec. To prevent this, AEC processing in the near end analyzes two important signals, the far end audio coming from the conferencing codec or phone input – also known as the AEC reference, and the same audio after being played over the near end speakers into the acoustic space and picked up by the mics. These two signals are analyzed in order to create and apply an adaptive filter to cancel out the far end audio captured at the mic.

The DMP 128 C models provide the flexibility to select the AEC reference signal at any input, output, or virtual return bus. The AEC reference can be independently selected for each of the eight channels of AEC processing.

Dante Audio Networking

TECHNOLOGY OVERVIEW

Dante technology from Audinate® provides digital audio distribution over standard local area networks. Dante allows high resolution audio channels to be transported uncompressed across a switched Ethernet data network using standard TCP/IP protocols, while meeting the stringent quality requirements of professional audio. Dante was built on the IEEE 1588 Time Precision Protocol standard to derive a precise clocking mechanism for synchronization. As a result of this, latency of 1 ms is maintained across 10 network switch hops using Dante in a Gigabit Ethernet network. Digital audio signals are converted to packets at the edge of the network, then processed and transported to other Dante enabled devices.

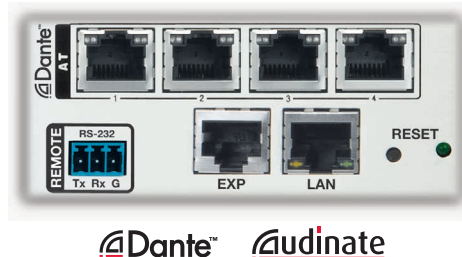

A network with Dante enabled devices can be shared with ordinary data traffic such as e-mail. Audio channels can be transported as unicast or multicast to make the most efficient use of available bandwidth.

With Dante, DMP 128 AT processors and AXP Series audio expansion processors can share multiple channels of high resolution digital audio with each other over a local area network. They can be directly linked to other processors using their built-in four-port Gigabit Ethernet switches or by connecting into a network infrastructure.

BENEFITS

An IP network of multiple DMP 128 AT and AXP Series processors provides greatly expanded I/O capacity while simplifying cable requirements for transporting dozens or hundreds of audio channels. An input or audio mix at one unit can be directed to any of the other devices on the network, for further DSP processing, mixing, and output to an audio destination such as a speaker zone.

A DMP 128 AT or AXP Series processor can also be used to share audio channels with third-party Dante equipped products such as multi-channel audio recorders, amplifiers, or mixing consoles without the need to use any of its local audio input or output ports.

- **Flexible channel routing**
Routing matrix of audio channels over standard Gigabit Ethernet networks
- **High quality digital audio**
Compression free, high resolution 24-bit digital audio transport
- **Extremely low latency**
 - Deterministic latency – in the sub-millisecond range with a guaranteed upper limit
 - Applicable for live sound
- **Easy, low cost cable management**
Connectivity using standard CATx cable
- **Flexible IT integration**
 - Uses standard Ethernet switches from Cisco, HP, Juniper Networks, Brocade, Avaya, etc. – simplifies new audio integration projects
 - IT managers have the flexibility to use preferred network switch vendor and network management tools
- **Reduces cost of audio upgrades**
DMP 128 AT processors can be added to an existing IT infrastructure

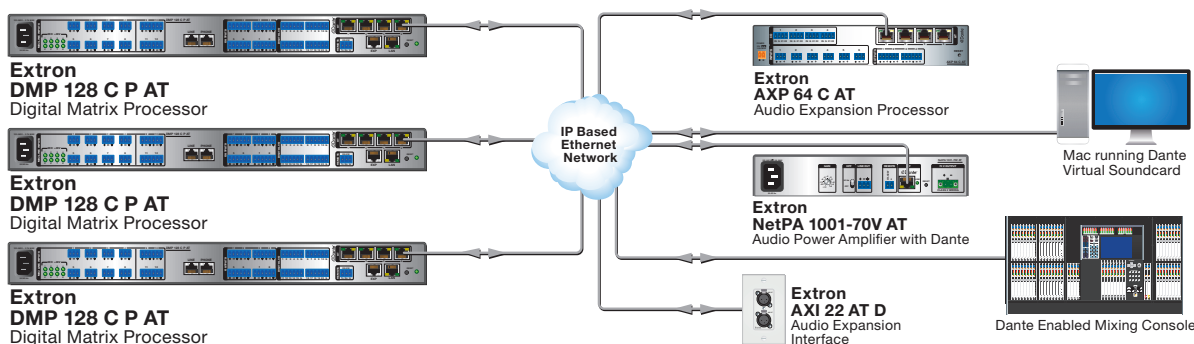

IP-based audio networking with the DMP 128 AT provides inherent scalability, allowing audio systems to be expanded simply by bringing additional processors and third-party Dante enabled devices into the network.

Dante Audio Networking

I/O EXPANSION USING AXP SERIES EXPANSION PROCESSORS AND DANTE

AXP Series audio expansion processors are unique in the industry in offering the flexibility of Dante networking to place inputs and outputs in remote locations with full DSP processing, including AEC, to simplify audio cabling infrastructure and reduce cable costs for integrators. A single Ethernet cable from an AXP 50 C AT or AXP 64 C AT audio expansion processor, or several linked units, to a DMP 128 AT processor in a central equipment rack greatly reduces the effort and expense of pulling one cable for each endpoint.

A sound system designer can incorporate several AXP Series processors to create a large mixing matrix with up to 56 remote inputs and 24 outputs per DMP 128 AT, all with 24-bit/48 kHz audio quality. In addition to using the Dante network, multiple DMP 128 AT and AXP Series units can be linked over their integrated four-port Gigabit switches. This greatly simplifies scalability as well as the cabling infrastructure.

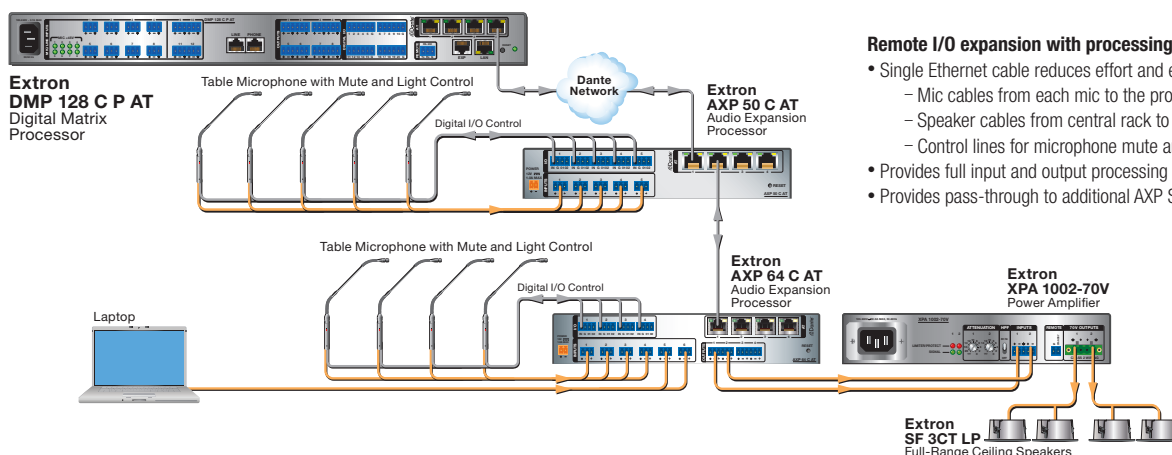

SETUP AND THE DANTE CONTROLLER SOFTWARE

Setting up a network of DMP 128 AT processors is simple and automatic. Once connected, a DMP 128 AT is self-configured with an IP address, and discovered by other processors and Dante enabled devices on the network. A user can route audio channels between devices using the Dante Controller software, which scans the network and provides an intuitive layout of all devices and their input and output channels, including the DMP 128 AT processors and their 56 available inputs and 24 outputs. Making audio routing assignments between devices is very simple with just a few clicks of a mouse.

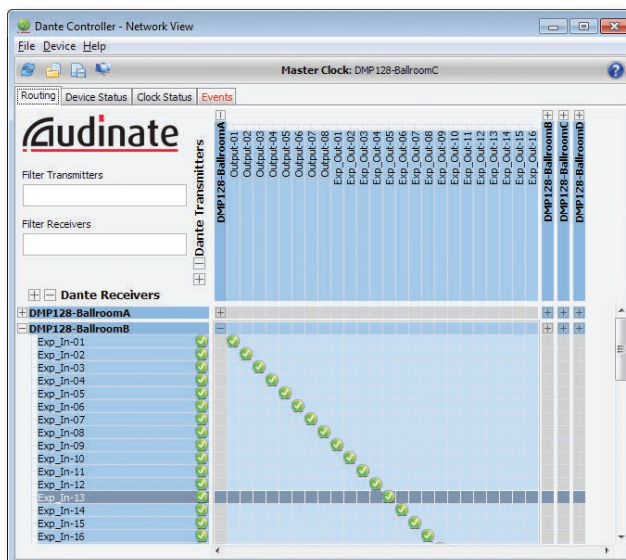

Features

Powerful Floating Point Audio DSP Engine

The DMP 128 features 32/64-bit floating point audio DSP processing, which maintains very wide dynamic range and audio signal transparency, to simplify management of gain staging while reducing the possibility of DSP signal clipping.

Low Latency DSP Processing

The DMP 128 features very low, deterministic latency from input to output, regardless of the number of active channels or processes. While latency increases in channels with AEC enabled, and marginally with the automixer, overall latency remains low. This keeps audio in sync with video, and prevents distractions to presenters or performers resulting from delayed live audio.

Copy and Paste for Processing Blocks

To help speed audio system design and setup, parameter settings can be quickly copied between individual processing blocks or identical groups of blocks within the Graphical User Environment, using conventional cut-and-paste commands.

Building Blocks Processor Settings

A collection of pre-designed processor settings optimized for a specific type of input or output device, such as microphones and Extron speakers, with preset levels, filters, dynamics, and more. Flexible Building Blocks are available on each I/O strip and allow system designers to fully customize and save their own Building Blocks, further streamlining audio system design and integration.

32 DSP Configurator Presets

Using the DSP Configurator Software, any parameters for DSP processing, levels, or audio routing can be saved as presets. These settings can be saved for the entire system, or any selected group of inputs, outputs, mix points, and DSP blocks.

Device Manager Enables Configuration of Multiple Extron DSP Products

Device Manager in the DSP Configurator Software enables easy configuration of multiple Extron DSP products, including linked or networked DMP 128 processors, by toggling between Graphical User Environments for each unit. Processors can be grouped into folders for organizing as separate rooms or buildings. Settings for multiple Extron DSP products in Device Manager can be saved to a single file.

20 Digital I/O Ports

Twenty configurable digital I/O ports are provided, so that the DMP 128 can be programmed to sense and then respond to external triggers such as mic activation, muting, and recall of presets.

Triple Matrix Design Provides Output, Virtual, and Expansion Routing Options

The DMP 128 employs a triple matrix design that offers substantial flexibility in routing, mixing, and processing audio input sources. The primary output matrix allows any of the 12 inputs to be matrix mixed to any or all eight outputs. If desired, any of the inputs can first be directed into the virtual matrix, which routes the inputs to eight virtual buses, before being mixed back into the output matrix. Virtual buses allow inputs to be processed together as a group. The expansion matrix provides signal routing between a DMP 128 and another DMP 128 or an Extron DTP CrossPoint matrix switcher. The expansion matrix is also used on DMP 128 AT models to distribute and receive audio from the Dante network.

Group Masters

The DMP 128 provides the capability to consolidate gain or mute control throughout the system. Gain or mute controls can be selected and added to a group master, which can then be controlled by a single

master fader or mute control. Each group master can have up to 16 members, and up to 32 group masters can be created.

Soft Limits Provide Optimal Group Master Adjustment Range

The group master volume range can be limited using soft limits to maintain optimal minimum and maximum levels when using external volume control. This prevents operators from over or under-adjusting levels when using digital I/O or RS-232 control. The DSP Configurator Software provides quick drag-and-drop adjustment of soft limits from the Group Controls screen.

Source and Output Signal Presence and Clipping LEDs

The DMP 128 provides LEDs on the front panel for each input and output, for real-time monitoring of signal presence. A separate LED illuminates as a warning whenever analog signal clipping is detected.

Flexible Control Options

The DMP 128 can be controlled using the DSP Configurator Software and a PC connection to the Ethernet port, the RS-232 serial port, or the USB 2.0 port on the front panel. The DMP 128 can also be controlled through a control system with Extron SIS™ - Simple Instruction Set commands, and by accessing the internal Web pages.

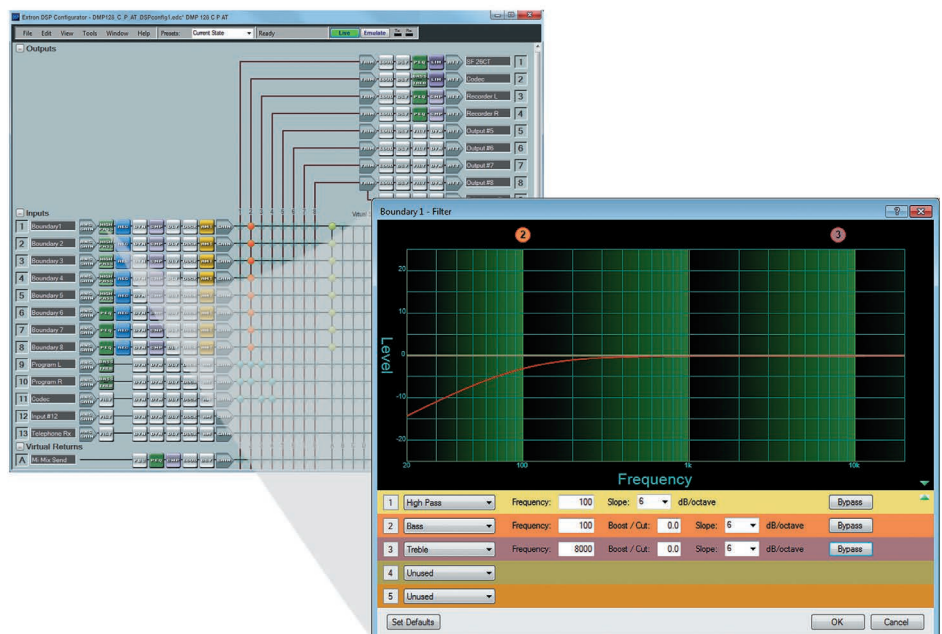

The DSP Configurator Software provides customizable filters at each input, output, and virtual bus for fine-tuning audio system performance.

Overview

USB Configuration Port

Enables easy setup and configuration without having to access the rear panel.

LAN and Expansion Port LEDs

Real-time signal activity indicators for the Ethernet and digital audio expansion ports.

Signal Presence and Clipping LEDs

Real-time signal activity and clip warning indicators for all input and output channels.



32/64-bit floating point audio DSP processing for wide dynamic range and signal transparency.



DMP 128 C P AT - Front

Extron Acoustic Echo Cancellation

DMP 128 C models include eight independent channels of Extron designed and engineered, high performance AEC processing with selectable noise cancellation.

Phantom Power

Selectable 48 V phantom power is available on inputs 1 to 8 for condenser mics.

POTS Interface

The DMP 128 C P AT includes RJ-11 jacks for a POTS line and a telephone handset.

Digital Audio Expansion Port

Link a DMP 128 with another DMP 128 or a DTP CrossPoint matrix switcher over shielded CAT 6 cable to share audio channels between them.

Dante Audio Networking and Four-Port Gigabit Ethernet Switch

Create larger audio matrixes over a local area network using standard Internet protocols. The integrated four-port Gigabit Ethernet switch also allows easy connectivity to other DMP 128 AT and AXP Series units.

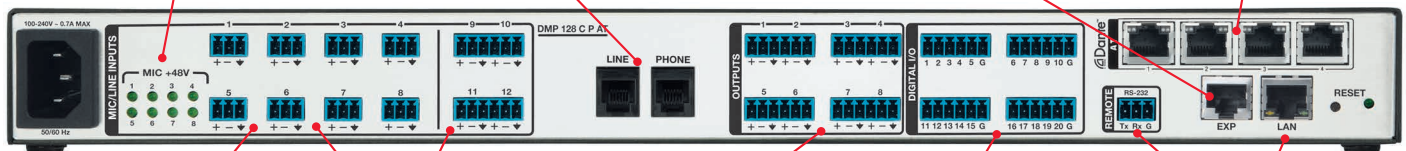

DMP 128 C P AT - Back

FlexInputs on DMP 128 AT Models

Inputs 1 - 8 on the DMP 128 C P AT are Flexinputs offering the additional capability to process Dante channels in place of local mic/line inputs.

12 Mic/Line Inputs

Studio grade 24-bit/48 kHz analog-to-digital converters for all inputs fully preserve source signal integrity.

Eight Line Outputs

Studio grade 24-bit/48 kHz digital-to-analog conversion ensures full dynamic range and signal quality at the outputs.

20 Digital I/O Ports

Functions within the DMP 128 can be remotely triggered, or the DMP 128 can trigger devices such as microphone tally lights.

RS-232 and Ethernet control ports

Convenient options are available for controlling and managing the DMP 128, whether from the DSP Configurator Software or a control system.

DSP Configurator

EASY-TO-USE DSP CONFIGURATOR SOFTWARE FOR FAST SETUP

The DSP Configurator Software features a Graphical User Environment that offers a clear view of all input and outputs, audio processing blocks, and mix points for output, virtual, and expansion bus routing in a single window. This allows a designer or installer to quickly view the entire configuration without having to access multiple windows or menus. The system view can easily be customized by hiding or collapsing sections of the Graphical User Environment, including the inputs, outputs, virtual buses, and expansion buses. Individual channels can also be hidden from view.

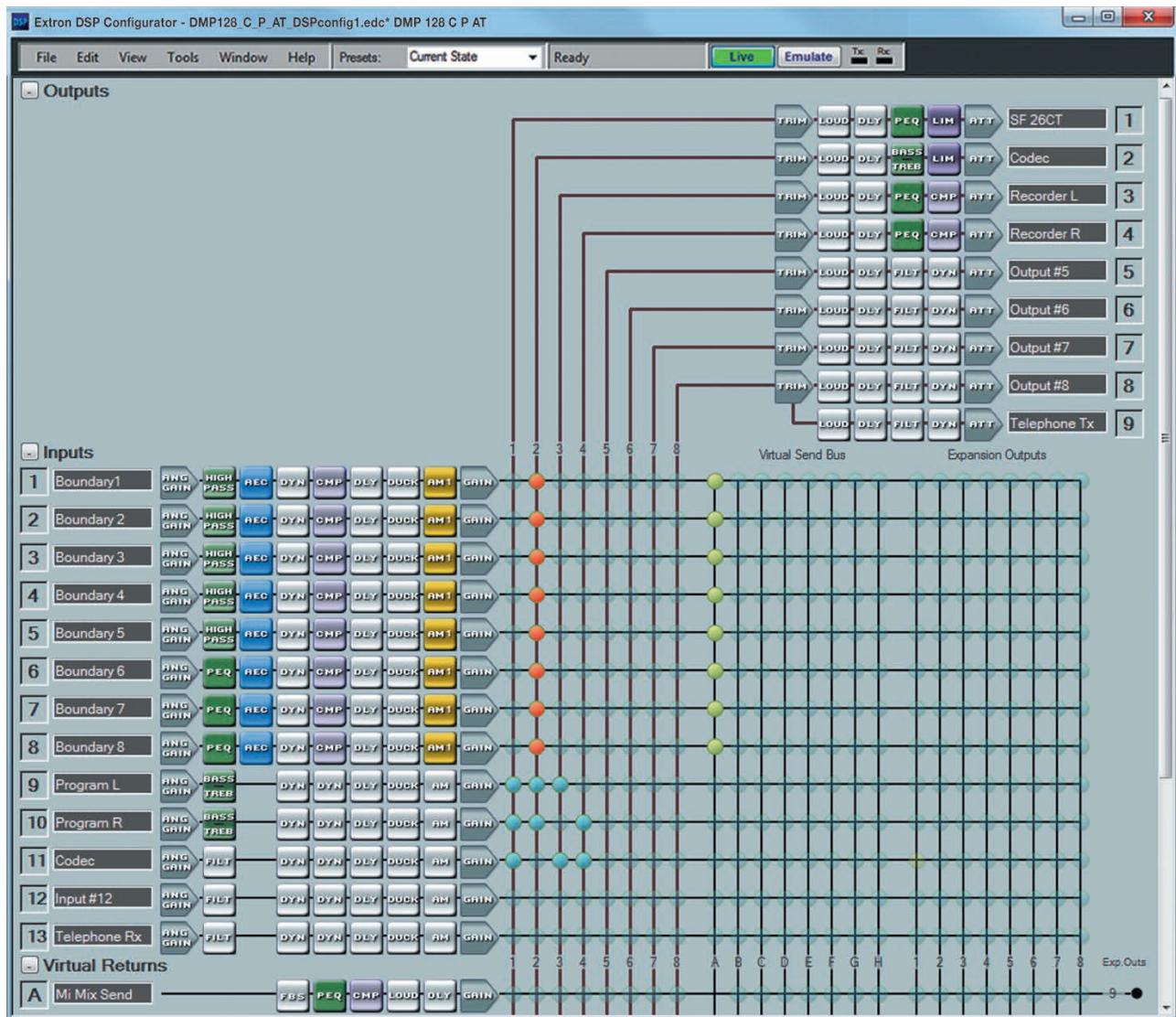

DSP Configurator

1 BUILDING BLOCKS

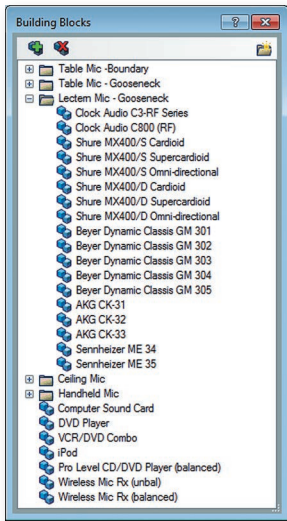

Extron Building Blocks are quick configuration tools for setting up microphones and other sources, speakers, and microphone and program mixes within the processor. Building Blocks provide predetermined gain levels, filters, equalization, and a small amount of protection against signal overload at the output digital-to-analog converters. They can be used to quickly get a sound system up and running, or as a starting point for further system setup and fine-tuning. For additional flexibility, system designers can customize existing Building Blocks or create their own.

FBS FEEDBACK SUPPRESSION

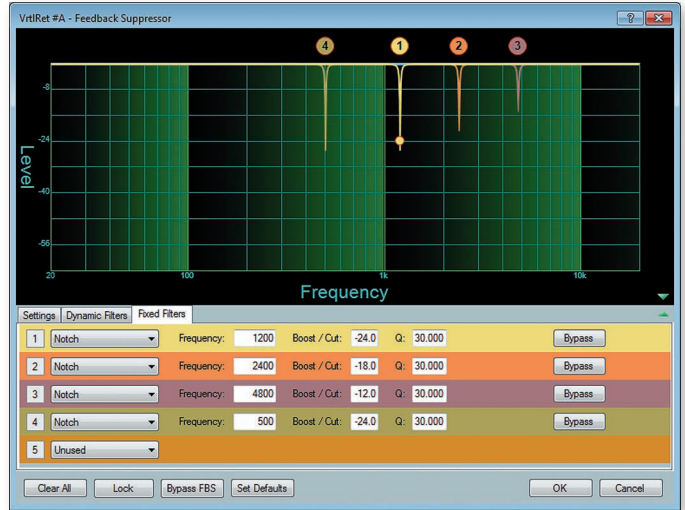

The FBS - Feedback Suppression Block is used to counteract ringing due to frequencies cycling out of control through the microphone and speakers. The feedback suppression processor for the DMP 128 engages up to twenty notch filters with adjustable Q. Fifteen of the filters are dynamic, and the processor automatically detects and then reduces the ringing. Five additional fixed filters can be adjusted manually or transferred from the dynamic filters.

AGC DYNAMICS & DELAY

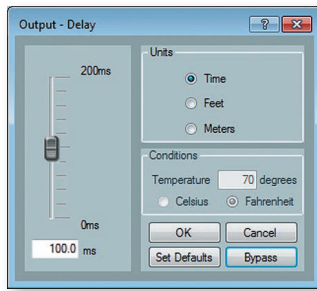
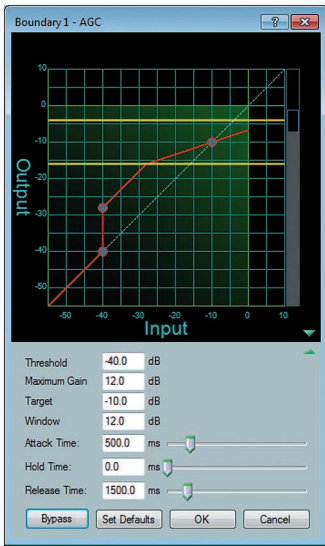

The DSP Configurator Software enables fine-tuning and adjustment of the dynamics of all incoming and outgoing signals. Two Dynamics processing blocks are available for each input. There is one Dynamics block on each virtual bus and output. These blocks can be selected and customized to provide automatic gain control, compression, limiting, or noise gating.

A Delay processing block is available for each input and output. Each delay is adjustable up to 200 ms, and can be selected in units of time, feet, or meters. A temperature parameter is available for distance adjustments.

FILTER FILTERING

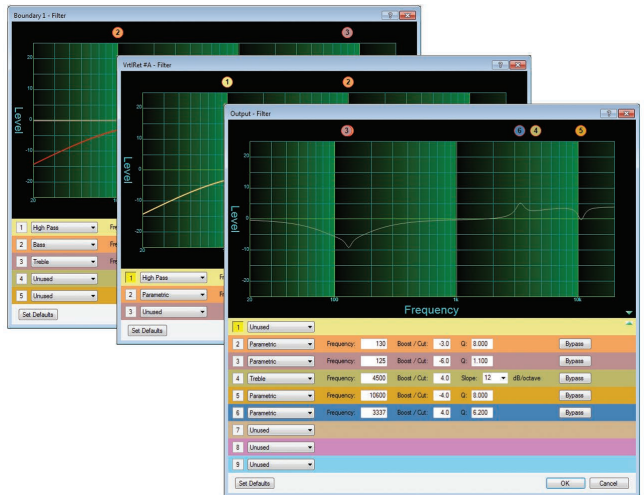

The Filter block offers five customizable filters for each input, three for each virtual bus, and nine for each of the outputs. Each of these filters can be selected as parametric EQ, low pass, high pass, or bass and treble shelving. Standard parameters include frequency, roll-off slope, boost/cut, and Q, depending on the specific filter.

Application

COURTROOM

The DMP 128 is ideal for meeting the different functional requirements for audio in a courtroom. The automixer is a particularly beneficial feature in courtroom proceedings, automatically managing microphone levels to maintain proper system gain before feedback and ensuring everything is clearly heard, whether one person or multiple people are speaking. The automixer features a "chairman mode" which can gate off all mics whenever the judge is addressing the courtroom. The DMP 128 includes eight outputs for sound reinforcement as well as an audio recorder and ALS - assistive listening system. Presets can be created with specific mics shut off, outputs to the audio recorder muted, or other functions or settings to support situations such as sidebar discussions between counsel and the judge.

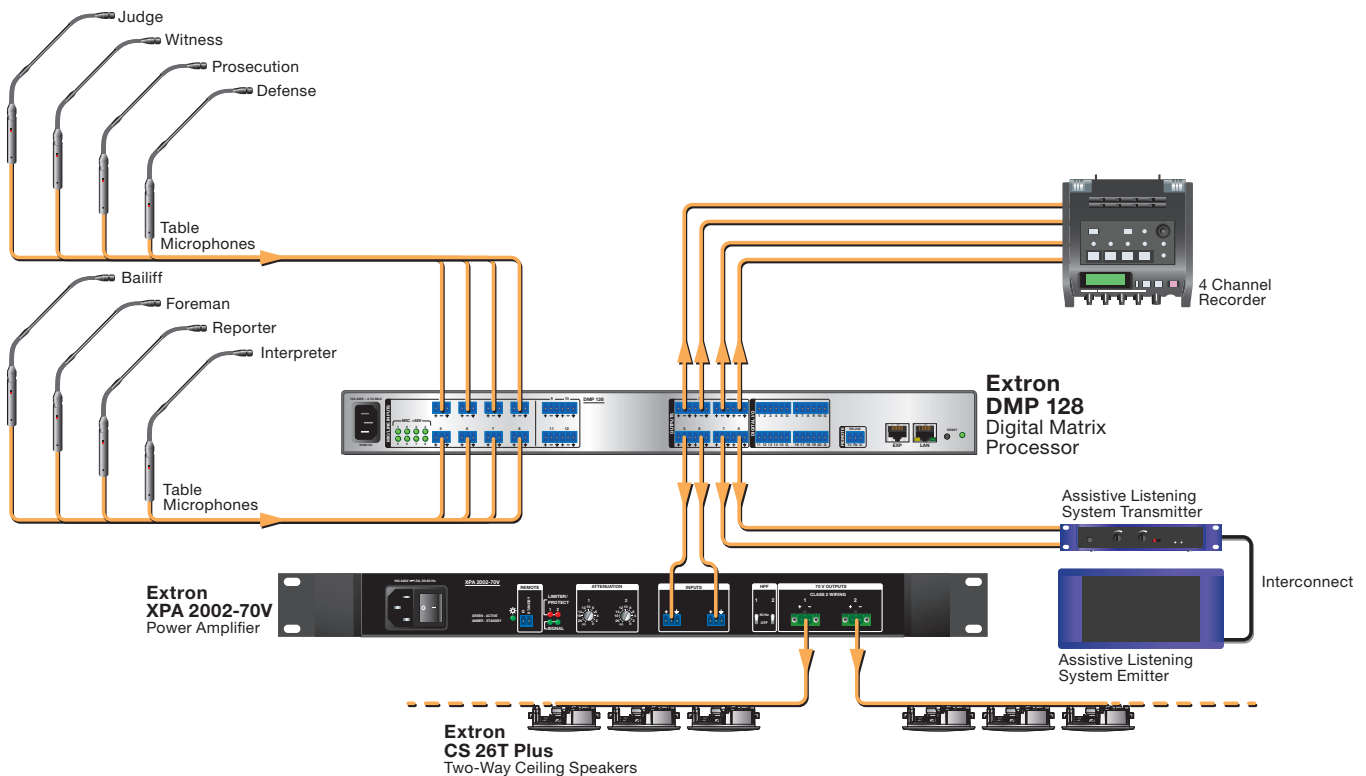

Application

BALLROOM

A large, divisible ballroom system requires the capability to set up and operate AV systems in various applications depending on how the rooms are being configured. The diagram below illustrates a system design for four ballroom subdivisions. A DMP 128 C P AT processor is assigned to each of the individual room audio systems. With all four processors networked together via Dante, flexible mixing and DSP configurations can be created for a variety of audio applications and room combinations. The automixer in a DMP 128 C P AT can be used to manage locally connected microphones, and also mics from other rooms. In this application, control and Dante are on separate networks. However, since Dante uses standard TCP/IP, these networks can optionally be bridged together.

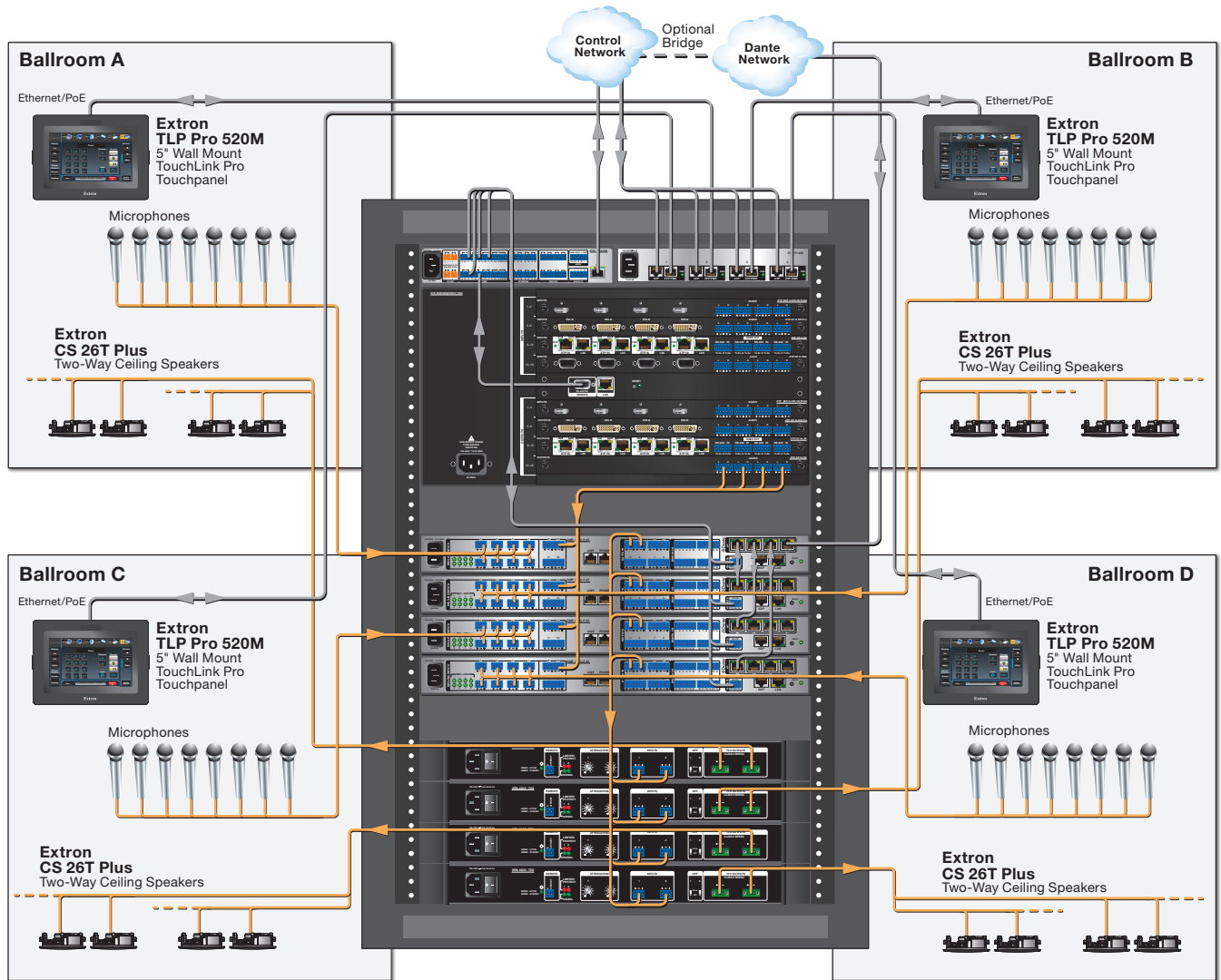

Rack:

- (1) Extron IPCP Pro 550 IP Link Control Processor
- (1) Extron XTP PI 400 XTP Power Injector
- (1) Extron XTP II CrossPoint 1600 Modular Digital Matrix Switcher
- (4) Extron DMP 128 C P AT Digital Matrix Processor
- (4) Extron XPA 4002-70V Power Amplifier

Application

TRAINING ROOM

The DMP 128 provides a diversity of audio functions to support the various applications of a training room, including lectures, student participation sessions, and distance learning. Two DMP 128 C P AT units handle the 20 total inputs for the instructor microphone, 16 microphones at the workstations, program audio from permanent AV sources and guest devices, and the videoconference codec. AEC processing supports far end talkers in a distance learning session, while the automixer self-manages the simultaneous use of several microphones during student participation. DSP processing for gain, EQ, tone, and more can be customized and fine-tuned for the program and ceiling speaker zones. Presets can be saved and recalled for different sound system functions based on the training room application.

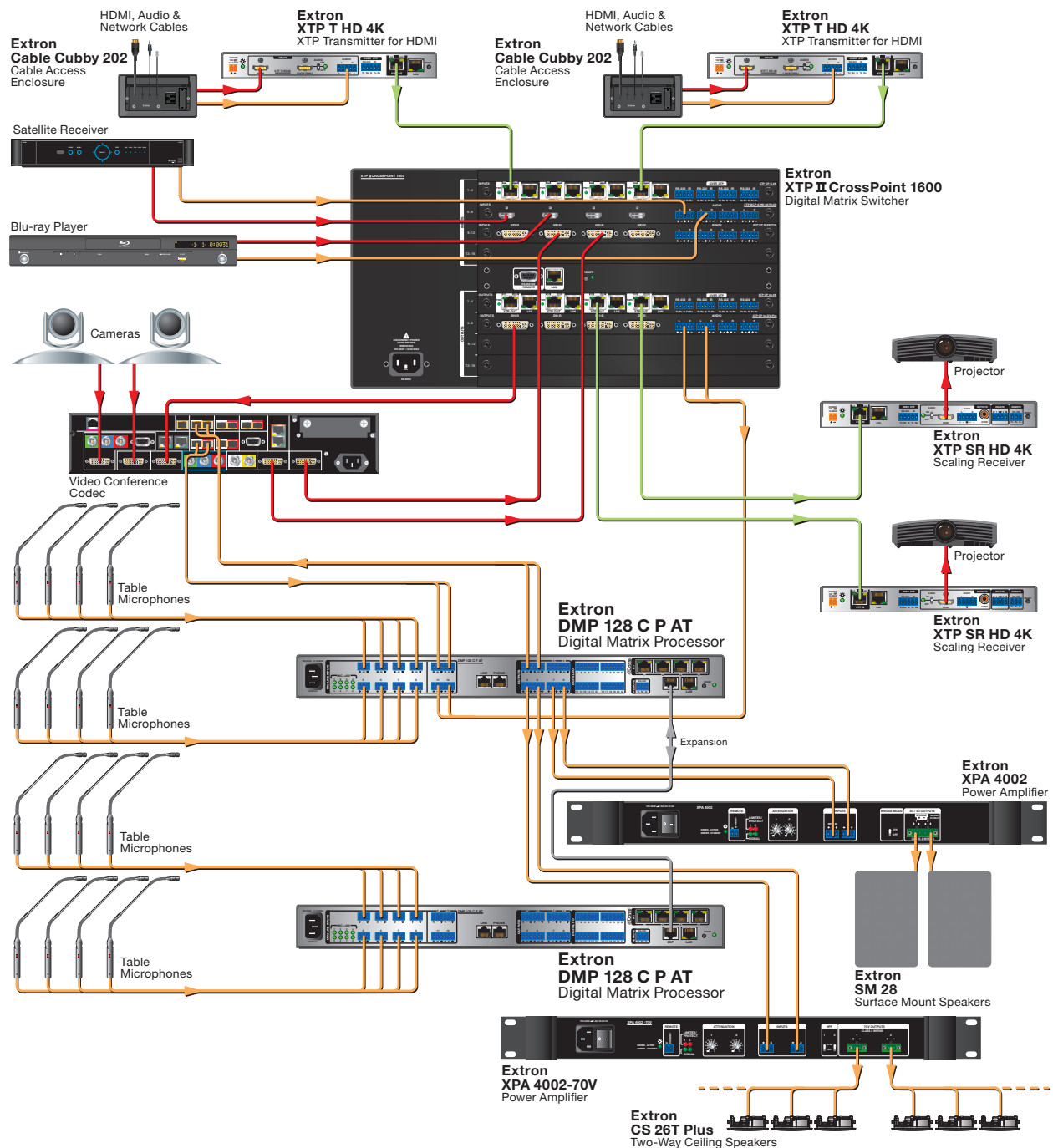

Application

DISTANCE LEARNING ROOM

Distance learning applications require a fully capable audio system to support conferencing. The audio system must deliver quality sound reinforcement, but more importantly, ensure that audio at the far end is absolutely clear and intelligible. The best way to accomplish this is to provide a tabletop microphone at every student location, paired with AEC in the DSP. Audio system designers can specify Extron AXP 50 C AT input expanders at designated locations throughout the room for connecting into microphones. Instead of running mic cables all the way back to the rack, each AXP 50 C AT connects into the main DMP 128 C P AT by way of a Dante Ethernet link. Additionally, the compact enclosure of AXP 50 C AT allows inconspicuous placement underneath a table or desk with optional Extron mounting accessories.

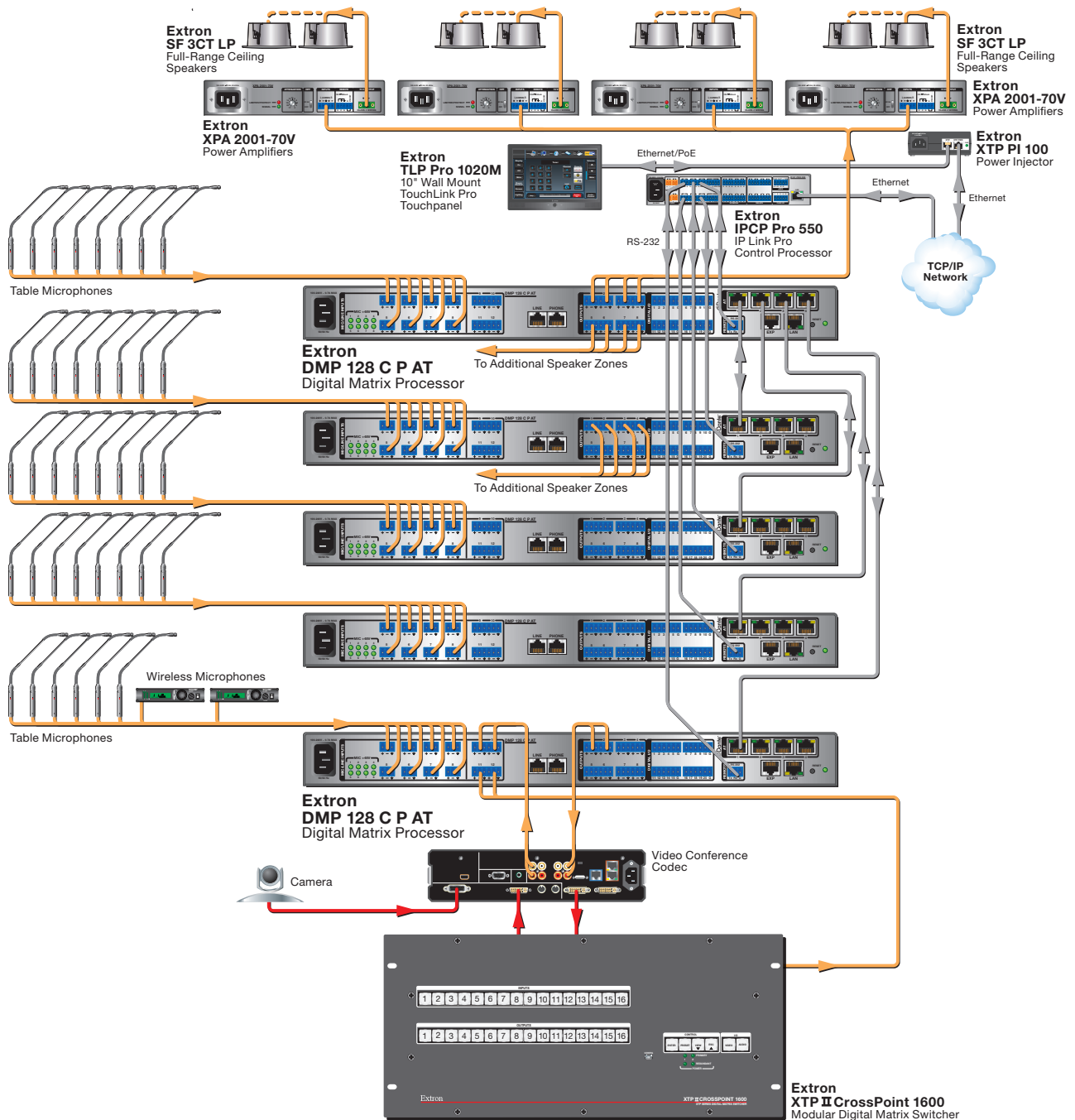

Specifications

AUDIO SYSTEM (MIC/LINE INPUT TO LINE OUTPUT)	
Gain	Unbalanced output: -6 dB; balanced output: 0 dB
Frequency response	20 Hz to 20 kHz, ± 0.2 dB
THD + Noise	<0.01%, 20 Hz to 20 kHz, at maximum level
S/N	>105 dB, 20 Hz to 20 kHz, at maximum balanced output, unweighted
Crosstalk	<-90 dB @ 20 Hz to 20 kHz, fully loaded
AUDIO INPUT	
Number/signal type	8 mono, mic/line, balanced/unbalanced (with phantom power)
Connector	(8) 3.5 mm captive screw connectors, 3 pole
Number/signal type	4 mono, mic/line, balanced/unbalanced (without phantom power)
Connector	(2) 3.5 mm captive screw connectors, 6 pole
Impedance	>10k ohms unbalanced/balanced
Nominal level	-60 dBV, +4 dBu, -10 dBV adjustable via input gain
Maximum level	+21 dBu at rated THD+N when mic gain is set to 0 dB
CMRR	>60 dB typical
DC phantom power	+48 VDC, $\pm 10\%$ (inputs 1-8) can be switched on or off
AUDIO OUTPUT	
Number/signal type	8 mono, (or 4 stereo) balanced/unbalanced
Connectors	(4) 3.5 mm captive screw connectors, 6 pole
Impedance	50 ohms unbalanced, 100 ohms balanced
Gain error	± 0.1 dB channel to channel
Maximum level (Hi-Z)	>+21 dBu balanced, +15 dBu unbalanced
AUDIO PROCESSING	
A/D, D/A conversion	24 bit, 48 kHz sampling
AEC tail length	>200 msec
AEC convergence	up to 60 dB/sec
Noise cancellation	up to 20dB, software selectable
EXP PORT	
Transmission type	Proprietary
Connectors	(1) RJ-45 connector
Inputs	16 channels Rx
Outputs	16 channels Tx
Audio format	24 bit, 48 kHz sampling, uncompressed
EXP cable	Shielded CAT6 up to 10 meters (1 foot cable included)
TELEPHONE PORTS (DMP 128 C P AND DMP 128 C P AT ONLY)	
Frequency response	300 to 3200 Hz
Input gain	-18 to +20 dB in 0.1 dB steps, software adjustable
Output gain	-100 to 0 dB in 0.1 dB steps, software adjustable
Dynamic Range	>60 dB, "A" weighted
AT PORTS (DMP128 C P AT ONLY)	
Transmission type	Dante over TCP/IP; AES67 ready
Connectors	(4) RJ-45 connectors, 4-port 1 Gbps switch
Inputs	56 channels Rx
Outputs	24 channels Tx
Audio format	24 bit, 48 kHz sampling, uncompressed
Latency	Deterministic, based on user selections: 0.15 ms, 0.25 ms, 1.0 ms (default), 5.0 ms

CONTROL/REMOTE – AUDIO PROCESSOR		
Serial host control port	1 bidirectional RS-232, 3.5 mm captive screw connector, 3 pole	
Baud rate and protocol	38400 baud, 8 data bits, 1 stop bit, no parity	
USB control ports	1 front panel female mini USB B	
Ethernet host port	1 RJ-45 female	
Ethernet data rate	10/100Base-T, half/full duplex with autodetect	
Web server	Up to 200 simultaneous sessions 6.5 MB nonvolatile user memory	
Program control	Extron control/configuration program for Windows® Extron Simple Instruction Set (SIS™) Microsoft® Internet Explorer®, Telnet	
GENERAL		
Power	Internal Input: 100-240 VAC, 50-60 Hz	
Power input requirements	28 watts	
Cooling	DMP 128: Convection All other models: Fan, right to left	
Mounting	Rack mount Yes, with included brackets	
Enclosure dimensions	1.7" H x 17.4" W x 9.5" D (1U high, full rack wide) (4.3 cm H x 44.2 cm W x 24.1 cm D) (Depth excludes connectors.)	
Product weight	2.8 lbs (1.3 kg)	
Shipping weight	4.5 lbs (2 kg)	
Regulatory compliance	Safety CE, c-UL, UL EMV/EMC CE, C-tick, FCC Class A, ICES, VCCI Environmental Complies with the appropriate requirements of RoHS, WEEE	
Warranty	3 years parts and labor	
NOTE: All nominal levels are at $\pm 10\%$.		
Model	Version Description	Part number
DMP 128	12x8 ProDSP Processor	60-1211-01
DMP 128 C P	12x8 ProDSP Proc. w/AEC and POTS	60-1179-01
DMP 128 C P AT	12x8 ProDSP Proc. w/AEC, POTS and Dante	60-1179-10
AXI 22 AT D	2 In, 2 Out Expansion Interface - Decorator-Style - Black	60-1517-02
AXI 22 AT D	2 In, 2 Out Expansion Interface - Decorator-Style - White	60-1517-03
AXI 22 AT	2 In, 2 Out Expansion Interface	60-1627-01
AXI 44 AT	4 In, 4 Out Expansion Interface	60-1628-01
AXP 50 C AT	5 Input Expansion Processor	60-1325-01
AXP 64 C AT	6 In, 4 Out Expansion Processor	60-1499-01
NetPA 502 AT	Two Channel Amp with Dante - 50 Watts/Ch	60-1500-01
NetPA 1001-70V AT	70 V Mono Amp with Dante - 100 Watts	60-1501-01

For complete specifications, please go to www.extron.com
Specifications are subject to change without notice.

WORLDWIDE SALES OFFICES

Anaheim • Raleigh • Silicon Valley • Dallas • New York • Washington, DC • Toronto • Mexico City • Paris • London • Frankfurt
Madrid • Stockholm • Amersfoort • Moscow • Dubai • Johannesburg • Tel Aviv • Sydney • Melbourne
New Delhi • Bangalore • Singapore • Seoul • Shanghai • Beijing • Hong Kong • Tokyo

www.extron.com