

# NAV Pro AV over IP

POWERFUL · SCALABLE · SECURE

## NAV PRO AVoIP



 PURE3

VECTOR 4K  
SCALING

18 Gbps  
4K/60 4:4:4

DoDIN APL  
APPROVED PRODUCT

## Lossless Video · Ultra-Low Latency · Low Bit Rates

- ▶ High quality distribution and switching of video, audio, USB, and Ethernet over standard IP networks
- ▶ 4K/60 with 4:4:4 chroma sampling
- ▶ Ultra-low latency with lossless video encoding using the patented Extron PURE3® codec
- ▶ PURE3 Intelligent Selective Streaming achieves exceptionally low bit rates with low motion content while maintaining lossless performance
- ▶ Fully integrated with the powerful and easy to use Extron Pro Series control system
- ▶ AES67 audio over IP standard provides interoperability with Extron and third party audio DSP processors
- ▶ Secure by design with encrypted control and content, 802.1X Network Access Control, integration with Pro Series Control, and Active Directory Support.
- ▶ Department of Defense Information Network Approved Product version available - DoDIN APL.

# Extron

# NAV Series

The NAV® Series is the only no-compromise Pro AV over IP solution for the distribution and switching of ultra-low latency, high-quality video, audio, USB and Ethernet signals over standard IP networks at low bit rates. It delivers revolutionary performance with real-time, lossless video over IP at resolutions up to 4K @ 60 Hz with 4:4:4 chroma sampling. The NAV Series offers both 1 and 10 Gigabit Ethernet encoders and scaling decoders with full interoperability across both systems. NAV can be deployed as a high-performance, IP-based video, audio, and USB matrix, combining the flexibility and scalability of a Pro AV over IP system with the integration friendly switching features found in traditional Extron matrix switchers.

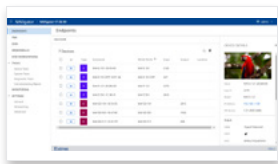

The NAVigator System Manager has an intuitive browser interface that makes the NAV System easy to setup, easy to use, and easy to maintain. NAV endpoints can be auto-discovered and configured in minutes and the NAVigator can apply updates to all endpoints simultaneously with just a few mouse clicks. The NAV Series is also fully integrated with the Extron Pro Series Control System, which enables simple, reliable, and secure control from Extron Touchpanels or keypads.



PURE3® is a groundbreakingly powerful, purpose-built codec designed specifically for Pro AV. By leveraging our expertise in video transmission and our knowledge of the Pro AV market and applications, we created PURE3 from the ground up to address the unique needs of the professional AV industry. PURE3 delivers lossless video at 4K/60 with ultra-low latency and efficient bit rates.



Vector™ 4K Scaling Technology is the latest generation of Extron scaling engines, specifically engineered for critical-quality 4K signal processing. The Vector 4K scaling engine delivers the power and precision required to manage the high pixel counts of today's 4K displays and content. Vector 4K Scaling enables NAV seamless switching and WindoWall® videowall capabilities.

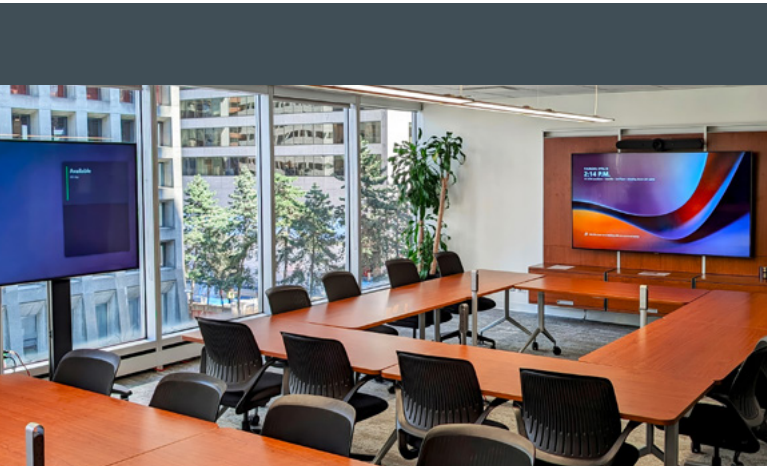

NAV Pro AV over IP enables dynamic designs that are flexible, scalable, and extensible. From the boardroom to the classroom, NAV Pro AV over IP distributes and switches lossless video, audio, USB, and Ethernet over standard IP networks. Utilizing the Extron patented PURE3 codec, the NAV system delivers groundbreaking performance with real-time, lossless video at resolutions up to 4K / 60 Hz with 4:4:4 chroma sampling. Integration with Extron Pro Series Control Systems deliver powerful solutions that are easy to setup, easy to use, and easy to maintain.



## PURE3 Codec

The Extron PURE3 codec patented, wavelet-based, compression technology offers improved network resiliency. The PURE3 codec tolerates bursty network traffic found on converged networks while exceeding the performance characteristics of standards-based compression systems. Others rely on delicate third-party codecs that fail when exposed to unpredictable network traffic. Those codecs require costly isolated networks, but PURE3 is the ONLY codec designed for the Pro AV industry that delivers robust, pristine video on converged or isolated networks. With sub-frame latency, PURE3 processes video signals with 4:4:4 color quantization, while maintaining the original source quality and native resolution. PURE3 Intelligent Selective Streaming is an exclusive Extron technology that leverages periods of low motion in streamed content to enhance streaming performance. The PURE3 codec also features advanced error concealment, providing high immunity to network errors such as bit errors, jitter, and out-of-order, or dropped data packets. PURE3 error concealment provides robust picture delivery without the increased latency or bandwidth typically introduced by other error correction schemes.



**Error Concealment**



**Efficient Bitrates**



**Ultra-Low Latency**



**Lossless Video**



**4: 4: 4 Chroma Sampling**

## Easy Setup and Configuration

The NAVigator and NAV endpoints feature a user-friendly, browser interface for easy access and configuration from a standard browser.

## System Monitoring and Control

The NAVigator System Manager turns any NAV system into a powerful and flexible IP-based matrix solution. The NAVigator is a secure, purpose-built appliance with an intuitive browser interface for centralized configuration, management, and control of NAV Systems. It facilitates easy setup, configuration, and switching, and includes extensive features for monitoring, diagnostics, and troubleshooting. NAVigator also facilitates bulk firmware upgrades, simultaneous configuration, backup, and restoration of multiple units from a single browser. Finally, the NAVigator integrates with the Extron Pro Series Control System for powerful, flexible, and secure extended control of IP Link Expansion Ports.

## Robust Security

NAV endpoints support 802.1X port-based Network Access Control. When applied, 802.1X authentication requires that all devices are approved before network access is granted. Additionally, the Secure Real Time Transport Protocol -

SRTP encrypts video, audio, and data streams with AES encryption. When the NAVigator System Manager is utilized, all communication between the NAVigator and NAV endpoints is encrypted with SSH – Secure Shell protocol. Also, NAV endpoints with an optical Ethernet interface are inherently secure and immune to electromagnetic and radio frequency interference, making them ideal for highly sensitive, secure environments. To further enhance security, NAV endpoints are IP Link Secure Platform Devices. Extron Pro Series Control Systems and NAV endpoints encrypt all commands between control processors and endpoints. These features and more have earned the NAV Series inclusion on the Department of Defense Information Network (DoDIN) Approved Products List (APL) for use in the most secure information and network infrastructures.

## Scalability

The flexible nature of IP networks ensures NAV systems are highly scalable and easily expandable to grow with any organization. With the highly efficient PURE3 codec, NAV delivers unrivaled video quality at low bitrates, which means it does not need the extreme uplink bandwidth required by other AV over IP systems when connecting multiple switches. All these features make NAV the most scalable system in the market.

# FEATURES

## **Stream AV signals over IP networks**

Standard IP streaming supports flexible system design and efficient transmission to many receivers over large distances and to any location

## **Supports HDMI at video resolutions up to 4K/60 with 4:4:4 chroma sampling**

HDMI up to 4K / 60Hz (4096 x 2160) with full 4:4:4 chroma sampling ensures accurate reproduction of source images with no loss of detail.

## **PURE3® Codec**

The patented PURE3 codec delivers lossless 4K/60 4:4:4 video with ultra-low latency and efficient bit rates. PURE3 tolerates the bursty network traffic found on converged networks. It is the ONLY codec designed for the Pro AV industry that delivers robust, pristine video on converged or isolated networks.

## **PURE3 Intelligent Selective Streaming**

Achieves exceptionally low bit rates with low motion content while maintaining lossless performance.

## **1 and 10 Gig interoperability**

NAV systems feature seamless, interoperability between 1 and 10 Gbps endpoints for flexible system design across the entire enterprise.

## **Fast reliable switching**

Multiple encoders and decoders can be deployed together to create an IP-based video, audio, and USB matrix, combining the flexibility of an IP-based system with the switching performance and integration-friendly features found in conventional Extron matrix switchers.

## **NAVigator System Manager**

Secure, centralized configuration, management, and control of NAV systems. NAVigator offers bulk setup, configuration, and upgrade as well as easy switching, and extensive features for monitoring, diagnostics, and troubleshooting.

## **Intuitive browser interface**

Both NAVigator and NAV endpoints provide an intuitive, user-friendly browser interface that simplifies device configuration, setup, and maintenance.

## **SmartGlide™ KVM Workstation**

Up to 8 displays managed per workstation in configurable with a single keyboard and mouse. SmartGlide KVM Switching automatically changes focus and control as the mouse glides to the next display. SmartGlide KVM Focus optionally highlights the active display.

## **USB 2.0 extension and switching**

Built-in USB Type-C® port facilitates extension of peripheral USB 2.0 devices over the same interface as video and audio. Ideal for KVM applications or remote connectivity for USB cameras or storage devices.

## **HDCP 2.3 compliant**

Ensures display of content-protected media and interoperability with other HDCP-compliant devices.

## **Power over Ethernet**

NAV encoders and decoders may be powered over the Ethernet cable, eliminating the need for bulky local power supplies.

## **Breakaway enables independent video, audio, and USB switching**

Provides capability to break away an audio or USB signal from its corresponding video signal.

## **AES67 audio support**

The AES67 audio over IP standard provides interoperability with Extron and third party DSP audio processors.

## **Adjustable bit rate**

Select bit rates while maintaining image quality for more flexible network configurations that easily adapts to application requirements.

## **Error concealment**

Delivers high immunity to network errors, ensuring reliable transmission of high quality video with the ability to conceal errors even during incidents of heavy packet loss.

## **HDMI loop-through local display**

HDMI output provides signal for a local display, an AV system, or a hardware codec, enabling monitoring or sharing of content.

## **WindoWall®**

Up to 64 displays may participate in a NAV videowall using the Extron WindoWall System. Enabling a mix of full screen and image magnification across multiple displays, NAVigator presets provide a quick and easy way to manipulate the videowall canvas among different image arrangements.

## **Advanced Extron Vector™ 4K scaling technology**

Vector 4K scaling ensures critical-quality 4K imagery, with best in class image upscaling and downscaling, enhanced color accuracy, and picture detail.

## **EDID Minder® automatically manages EDID communication between connected devices**

Ensures that all sources power up properly and reliably output content for display.

## **Key Minder® continuously verifies HDCP compliance for quick, reliable switching**

Key Minder authenticates and maintains continuous HDCP encryption between input and output devices to ensure quick and reliable switching in professional AV environments, enabling simultaneous distribution of a single source signal to one or more displays.

## **HDCP Visual Confirmation**

When HDCP-encrypted content is transmitted to a non-HDCP compliant display, a full-screen green signal is sent to the display for immediate visual confirmation that protected content cannot be viewed on that display.

## **IP Link Expansion Ports**

Designed to integrate directly with Extron Pro Series control systems for secure, encrypted RS-232, IR, Digital I/O, and Tally control of external devices without the need for additional control processors at the endpoints.

## **IP Link Secure Platform Device**

Extron Pro Series control systems offer flexible system management and matrix switching control to IP Link Secure Platform Devices and encrypts all commands from the control processor to endpoint.

# OVERVIEW

## ENCODER

### Convenient access for configuration

Mini USB port provides easy access for configuration changes and updates

### Monitor NAV signals

Status LEDs enable easy verification of HDCP encryption, video, audio, and USB stream presence

### Check active audio output

Audio status LEDs indicate the presence of active audio

### Confirm USB status

USB LEDs show the USB mode and status

### Monitor network connectivity

LAN LEDs show the status of the NAV streaming link and the Ethernet expansion link

### Quickly identify unit on the network

ID LED and button helps to quickly identify units on the network

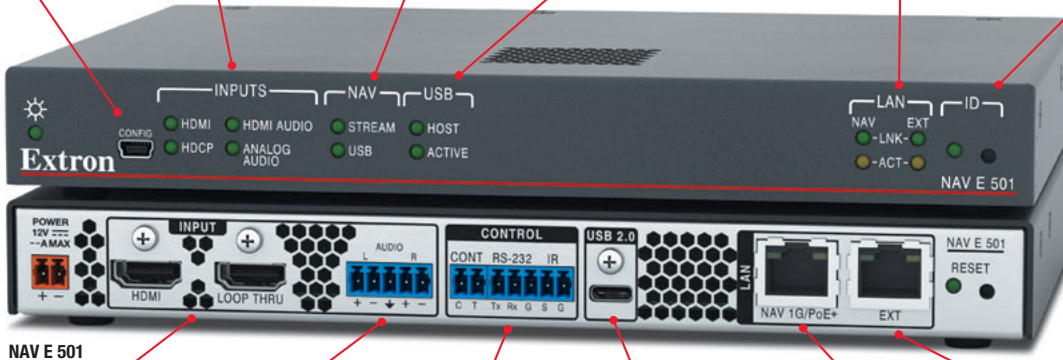

### Video resolutions up to 4K/60 @ 4:4:4

HDMI input and loop-through supports 4K/60 with 4:4:4 chroma sampling

### Separate analog audio input

5-pole captive screw provides balanced or unbalanced analog audio input

### Control remote devices

Pro Series control port enables remote RS-232 and IR remote port access.

### USB connectivity for KVM and other applications

USB-C port for USB 2.0 connection of peripheral devices

### Stream over standard IP networks

Industry standard copper Gigabit Ethernet with PoE+. Models available with 1 or 10 Gig single or multimode fiber

### Expand Ethernet connectivity to remote locations

RJ-45 1 Gigabit Ethernet expansion port enables connectivity to remote LAN devices

## DECODER

### Convenient access for configuration

Mini USB port provides easy access for configuration changes and updates

### Monitor NAV signals

Status LEDs enable easy verification of HDCP encryption, video, audio, and USB stream presence

### Check active audio output

Audio status LEDs indicate the presence of active audio

### Confirm USB status

USB LEDs show the USB mode and status

### Monitor network connectivity

LAN LEDs show the status of the NAV streaming link and the Ethernet expansion link

### Quickly identify unit on the network

ID LED and button helps to quickly identify units on the network

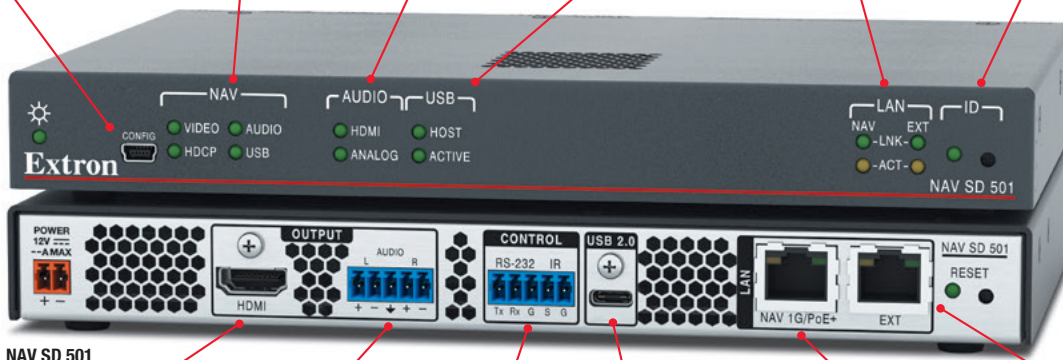

### Scale and output video

HDMI 2.0 output with 4K/60 and 4:4:4 chroma sampling support

### Extract analog audio

5-pole captive screw provides balanced or unbalanced analog audio output

### Control remote devices

Pro Series control port enables remote RS-232 and IR SPD port access

### USB connectivity for KVM and other applications

USB-C port for USB 2.0 connection of peripheral devices

### Stream over standard IP networks

Industry standard copper Gigabit Ethernet with PoE+. Models available with 1 or 10 Gig single or multimode fiber

### Expand Ethernet connectivity to remote locations

RJ-45 Gigabit Ethernet expansion port enables connectivity to remote LAN devices

## NAVIGATOR SYSTEM MANAGER

The NAVigator System Manager delivers simple configuration, management, monitoring, and troubleshooting tools that are key to a successful Pro AV over IP deployment. Manual configuration of every endpoint can be time consuming and troubleshooting can be a labor intensive without the right tools. The NAVigator System Manager was created specifically for the Pro AV integrator, with intuitive configuration, management, monitoring, and troubleshooting tools that make your NAV system easy to setup, easy to manage, and easy to maintain.

The NAVigator features a simple browser interface for centralized configuration, management and control. Integrators familiar with traditional Extron matrix switchers will find it easy to implement Pro AV over IP with the NAVigator, as it shares many of the same terminologies. All NAV communication is encrypted and secure, and access can be protected further with username and password authentication. The NAVigator features two LAN interfaces that allow the option to isolate management from the AV LAN, with easily accessible IP address settings along with a variety of configuration and backup options.

The NAVigator greatly enhances efficiency with bulk management tools that enable firmware upgrades, backup, or restoration of one or all the NAV endpoints with just a few mouse clicks. The NAVigator features enhanced matrix switching capabilities, that enable switching video, audio, or USB signals between individual devices or groups of devices simultaneously. It also delivers breakaway switching capability with independent routing of video, audio, or USB signals. In addition, the NAVigator can copy EDID settings from any attached display or select from a wide range of pre-defined settings, ensuring that all sources power up properly and reliably output content for display. Finally, the NAVigator System Manager provides intuitive alarm and monitoring features to assist administrators in quickly identifying issues and applying solutions.

The NAVigator also offers advanced features such as NAVigator Redundancy which enables the creation of a backup NAVigator to takeover in the event of a Main NAVigator failure creating a high availability NAV System. The failover occurs automatically without manual intervention. The NAVigator also provides an Automated System Backup capability that allows users to schedule the backup of NAVigator system configuration data. Another NAVigator feature is integration with Microsoft® Active Directory, to assist enterprises in managing users, groups, passwords, and access. This simplifies user management, group authentication, and helps maintain strong security policies.

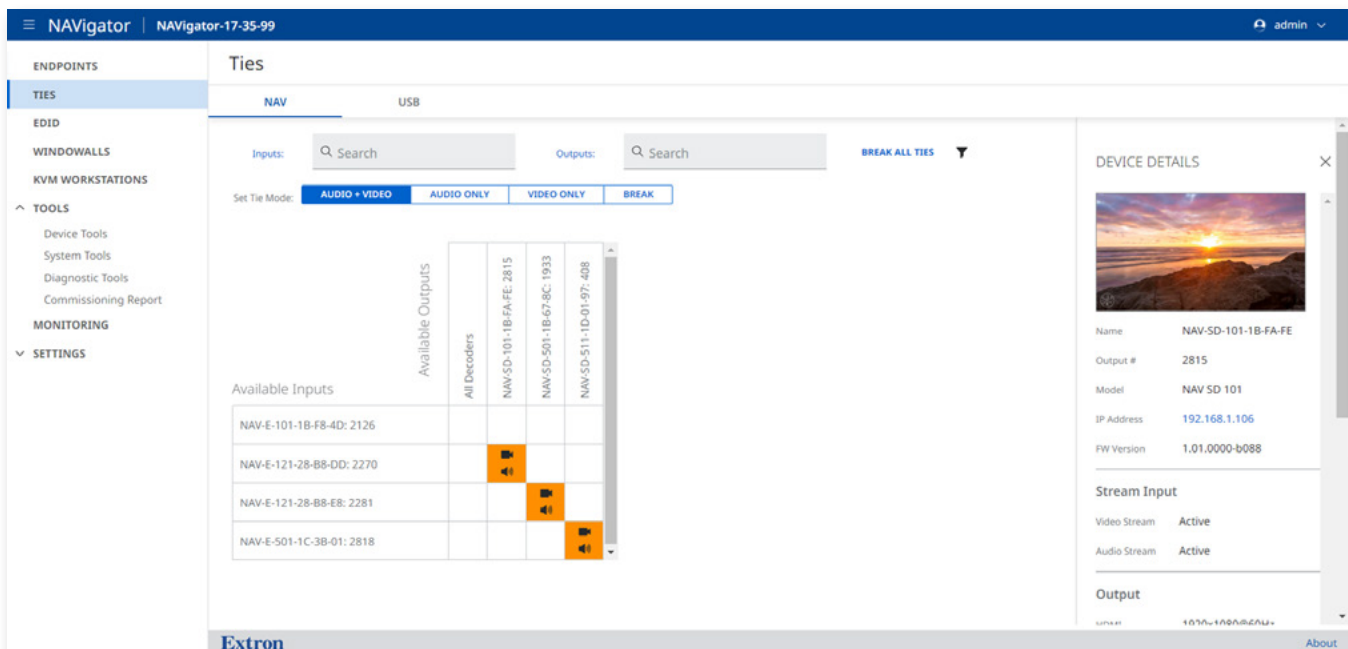

The screenshot shows the NAVigator System Manager interface. The main area is titled "Ties" and has tabs for "NAV" and "USB". There are search bars for "Inputs" and "Outputs". Below these are buttons for "Set Tie Mode" with options: "AUDIO + VIDEO", "AUDIO ONLY", "VIDEO ONLY", and "BREAK". A table shows "Available Inputs" and "Available Outputs".

| Available Inputs         | All Decoders | NAV-SD-101-1B-FA-FE: 2815 | NAV-SD-501-1B-67-8C: 1933 | NAV-SD-511-1D-01-97: 408 |
|--------------------------|--------------|---------------------------|---------------------------|--------------------------|
| NAV-E-101-1B-F8-4D: 2126 |              |                           |                           |                          |
| NAV-E-121-2B-B8-DD: 2270 |              | 🔊                         |                           |                          |
| NAV-E-121-2B-B8-E8: 2281 |              |                           | 🔊                         |                          |
| NAV-E-501-1C-3B-01: 2818 |              |                           |                           | 🔊                        |

The "DEVICE DETAILS" panel on the right shows:

- Name: NAV-SD-101-1B-FA-FE
- Output #: 2815
- Model: NAV SD 101
- IP Address: 192.168.1.106
- FW Version: 1.01.0000-b088
- Stream Input
  - Video Stream: Active
  - Audio Stream: Active
- Output

# CONTROL SYSTEM INTEGRATION

## IP LINK SECURE PLATFORM DEVICE

Control systems are an integral part of any quality AV installation, and the NAV system takes control to the next level. Unique Pro Series control integration turns any NAV endpoint into an extension of your Extron Pro Series control system. NAV encoders and scaling decoders feature built-in IP Link Expansion Ports for CEC, RS-232, tally, IR, and digital I/O, expanding your Extron Pro Series control system to anywhere the network can reach without additional hardware.

The NAV Pro Series control offers full integration with Extron TouchLink Pro touchpanels, eBUS button panels, and IP Link Pro control processors. With Extron Global Configurator or Global Scriptor, it's easy to configure and access NAV IP Link Expansion Ports on an encoder or scaling decoder. Device drivers and modules make it simple to control cameras, streaming boxes, and document cameras connected to NAV encoders, or projectors and displays connected to NAV decoders. With the NAV Series, the same IP Link Pro control processor that manages and controls your NAV video and audio switching can control multiple devices in remote locations. This unique Extron feature saves time and expense by eliminating the need for additional control processors at the endpoints.

NAV IP Link Expansion Ports are compatible with Extron Show Me cables for convenient connectivity and user input selection in collaborative environments. Operating a Show Me cable is convenient and straight-forward; simply connect an HDMI Show Me cable to a NAV encoder and press the Share button to instantly share your content onto the display.

All communications between the NAV System and Extron Pro Series control systems are encrypted, ensuring secure control of connected devices at any location. NAV solutions are ideal for any application requiring device control, flexible video, audio, USB, and Ethernet switching, and reliable transmission of high-quality content.

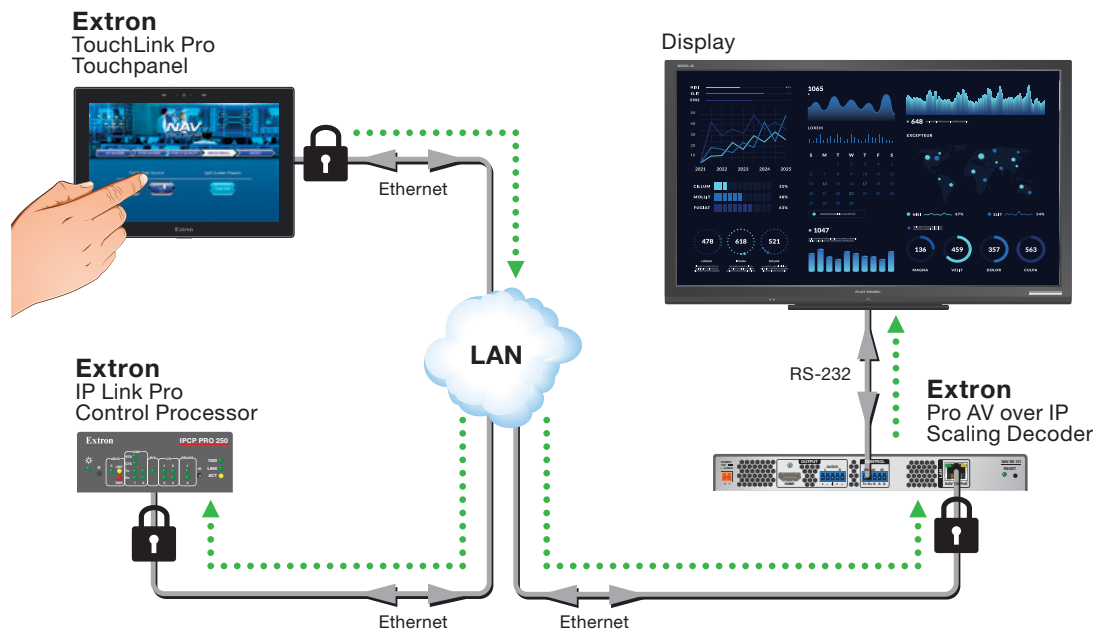



## NAVigator

The Extron NAVigator System Manager provides secure configuration, management, and control of the NAV Pro AV over IP systems. Use the intuitive, browser-based NAVigator to configure, monitor, control, update, backup, restore, run diagnostics, and troubleshoot. An entry level NAVigator system supports 16 endpoints and can expand with LinkLicense to support 48, 96, or 240 devices. Multiple NAVigator units working together can support thousands of NAV endpoints. Two isolated, independent LAN ports optionally facilitate a separate management network, enabling flexible designs with enhanced security, by eliminating AV traffic from the management network. Extron Pro Series controls work with the NAVigator as a centralized communication bridge for secure control of all attached devices. The NAVigator System Manager can be PoE powered by the network.

### Fast and Reliable Switching

NAV systems are not limited to video extension and distribution. Many encoders and decoders can be deployed together to create an IP-based video, audio, and USB matrix. NAV Pro AV over IP solutions provide the flexibility and scalability of an IP-based system, with the integration-friendly video, audio, and USB switching features found in conventional Extron matrix switchers, such as Key Minder®, EDID Minder®, and USB and audio breakaway. The Extron Pro Series control system with the NAVigator System Manager enhance matrix switching capabilities, featuring advanced control and enterprise-level system monitoring.

### Security

NAVigator System Manager encrypts all communication between the NAVigator and NAV endpoints with Secure Shell - SSH protocol, ensuring every command on the network is fully encrypted from control processor to endpoint. NAV endpoints also support 802.1X port-based Network Access Control. When applied, 802.1X authentication requires approval from all devices before granting network access. Support for Active Directory simplifies user management and group authentication, and Secure Real-Time Transport Protocol - SRTP ensures encryption, message authentication, and data integrity of video and data streams. The DoDIN APL is used by the United States military and DoD agencies to acquire devices that will be connected to the Defense Information Systems Network (DISN). The NAV System is ideal for use in the most secure information and network infrastructures.

| Model       | Version Description                  | Part Number | Model       | Version Description      | Part Number |
|-------------|--------------------------------------|-------------|-------------|--------------------------|-------------|
| NAVigator   | Entry level version for 16 Endpoints | 60-1534-01  | LinkLicense | Upgrade to 96 Endpoints  | 79-2551-03  |
| LinkLicense | Upgrade to 48 Endpoints              | 79-2551-02  | LinkLicense | Upgrade to 240 Endpoints | 79-2551-04  |

# 1G USB-C AND HDMI PRO AV OVER IP SWITCHING ENCODER



## NAV E 222

The NAV E 222 is a two-input, USB-C or HDMI® switching Pro AV over IP encoder that streams real-time, high-quality video and audio signals over 1 Gbps Ethernet at low bitrates. Versatile input switching modes are configurable as auto or manual switching. The encoder can power and charge a USB-C device with up to 100 watts using the optional UPI 100 Power Inserter. The NAV E 222 is compatible with NAV® endpoints, increasing scalability for large deployments. Utilizing Extron's patented PURE3® codec, the NAV E 222 delivers groundbreaking performance with visually lossless video at resolutions up to 4K/60 with 4:4:4 chroma sampling and ultra-low latency over IP networks. Support for embedded digital USB-C, HDMI, and AES67 audio over IP standard, facilitates flexible integration with Extron DMP Plus DSPs or other IP-enabled audio components. Purpose-built to support demanding professional AV applications, the highly scalable and powerful NAV platform enables secure deployment of AV signals to thousands of endpoints.

### Features

- Two-input USB-C and HDMI switching encoder with an HDMI loop out
- Supports resolutions up to 4K/60 with 4:4:4 chroma sampling
- PURE3® Codec delivers improved network resiliency
- Powers and charges a USB-C device with up to 100 watts using the optional UPI 100 power inserter
- Compact and economical HDMI video and audio encoding, distribution, and switching over 1 Gbps copper Ethernet interface
- HDMI 2.0 input and loop-thru at resolutions up to 4K/60 with 4:4:4 chroma sampling
- Extron-patented PURE3® codec capable of lossless 4K/60 4:4:4 video with ultra-low latency
- Confidence Preview of the encoder video is available in either the endpoint or NAVigator browser interface
- Configurable Power Priority selects PoE or line power priority for power management and redundancy
- PURE3 ISS - Intelligent Selective Streaming for efficient bit rates
- Interoperable with 1 and 10 Gbps NAV decoders
- AES67 audio streaming support
- HDCP 2.3 compliant
- SRTP stream encryption
- Audio breakaway enables independent audio and video switching
- SRTP stream encryption
- Customizable Screen Saver
- Priority Routing
- 802.1X port-based Network Access Control
- Active Directory support
- Adjustable bit rate
- Embedded browser interface
- EDID Minder® automatically manages EDID communication between connected devices
- Key Minder® continuously verifies HDCP compliance for quick, reliable switching
- HDCP Visual Confirmation
- Compatible with CATx shielded twisted pair cable
- Integrates with Pro Series control systems for secure, user-friendly external control
- CEC – Consumer Electronics Control capability
- IP Link Secure Platform Ports for extended Extron Pro Series Control of RS-232, IR, and Digital I/O
- Multicast filtering with IGMPv2/v3
- One-button endpoint identification
- 1.0" (25 mm) high, 8.75" (222 mm)

| Model     | Version Description    | Part Number |
|-----------|------------------------|-------------|
| NAV E 222 | 1G USB-C, HDMI Encoder | 60-2069-01  |

# 1G COMPACT PRO AV OVER IP ENCODER - HDMI

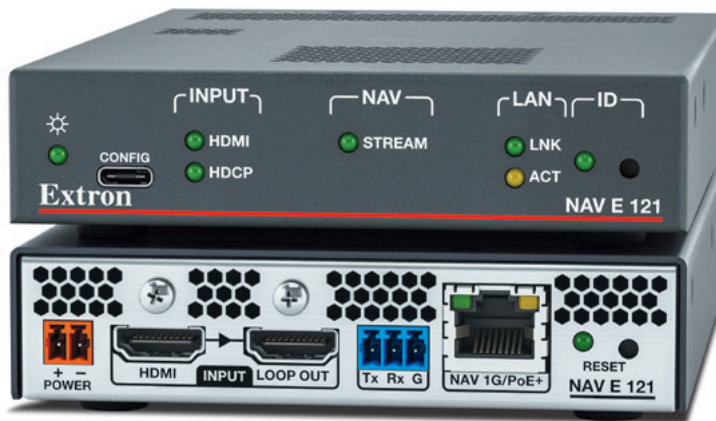

## NAV E 121

The NAV E 121 is a compact Pro AV over IP encoder that streams ultra-low latency, high-quality HDMI video and audio over a standard 1 Gbps copper Ethernet interface. Using the Extron patented PURE3® codec, the NAV® Series delivers groundbreaking performance with real-time, lossless video at resolutions up to 4K @ 60 Hz with 4:4:4 chroma sampling. The NAV E 121 includes a loop-thru for local monitoring. Support for embedded digital HDMI and AES67 audio over IP facilitates flexible integration with DMP Plus DSPs or other IP-enabled audio components. Purpose-built to support demanding professional AV applications, the highly scalable and powerful NAV platform enables secure deployment of AV signals to thousands of endpoints.

### Features

- Compact and economical HDMI video and audio encoding, distribution, and switching over 1 Gbps copper Ethernet interface
- HDMI input and loop-thru at resolutions up to 4K/60 with 4:4:4 chroma sampling
- Extron-patented PURE3® codec capable of lossless 4K/60 4:4:4 video with ultra-low latency
- PURE3 error concealment delivers high immunity to network errors without adding latency
- Confidence Preview of the encoder video is available in either the endpoint or NAVigator browser interface
- Configurable Power Priority selects PoE or line power priority for power management and redundancy
- PURE3 Intelligent Selective Streaming for efficient bit rates
- Interoperable with 1 and 10 Gbps NAV decoders
- AES67 audio streaming support
- HDCP 2.3 compliant
- SRTP stream encryption
- Audio breakaway enables independent audio and video switching
- SRTP stream encryption
- Customizable Screen Saver
- Priority Routing
- Active Directory support
- Adjustable bit rate
- Embedded browser interface
- 802.1X port-based Network Access Control
- EDID Minder® automatically manages EDID communication between connected devices
- Key Minder® continuously verifies HDCP compliance for quick, reliable switching
- HDCP Visual Confirmation
- Compatible with CATx shielded twisted pair cable
- Integrates with Pro Series control systems for secure, user-friendly external control
- CEC – Consumer Electronics Control capability
- IP Link Secure Platform Port for extended Extron Pro Series Control of RS-232
- Multicast filtering with IGMPv2/v3
- One-button endpoint identification
- Department of Defense Information Network Approved Product version available - DoDIN APL.
- ZipClip® 400 included for quick and secure mounting to under tables and lecterns
- Four encoders can be mounted in 1U with the optional RSB126
- 1.0" (25 mm) high, 4.3" (109 mm) wide quarter rack width metal enclosure, 6.0" (152 mm) deep

| Model     | Version Description     | Part Number |
|-----------|-------------------------|-------------|
| NAV E 121 | 1G HDMI Compact Encoder | 60-2040-01  |

# 1G COMPACT PRO AV OVER IP SCALING DECODER - HDMI



## NAV SD 121

The NAV SD 121 is a compact Pro AV over IP Scaling Decoder that receives NAV® high-quality ultra-low latency video, audio, and control over a standard 1 Gbps copper Ethernet interface. Using the Extron patented PURE3® codec, the NAV Series delivers groundbreaking performance with real-time, lossless video at resolutions up to 4K @ 60 Hz with 4:4:4 chroma sampling. The NAV SD 121 includes a loop-thru for local monitoring. Support for embedded digital HDMI and AES67 audio over IP facilitates flexible integration with DMP Plus DSPs or other IP-enabled audio components. Purpose-built to support demanding professional AV applications, the highly scalable and powerful NAV platform enables secure deployment of AV signals to thousands of endpoints.

### Features

- Compact, economical video and audio decoding, scaling, distribution, and switching over an industry standard 1 Gbps copper Ethernet interface
- HDMI 2.0 output at resolutions up to 4K/60 with 4:4:4 chroma sampling
- Extron-patented PURE3® codec capable of lossless 4K/60 4:4:4 video with ultra-low latency
- PURE3 error concealment delivers high immunity to network errors without adding latency
- Vector™ 4K Scaling Technology ensures critical quality 4K imagery
- Confidence Preview of the encoder video is available in either the endpoint or NAVigator browser interface
- Configurable Power Priority selects PoE or line power priority for power management and redundancy
- Interoperable with 1 and 10 Gbps NAV encoders
- AES67 input or output audio streaming support
- HDCP 2.3 compliant
- SRTTP stream encryption
- Audio breakaway enables independent audio and video switching
- SRTTP stream encryption
- Customizable Screen Saver
- Priority Routing
- Active Directory support
- Adjustable bit rate
- Embedded browser interface
- 802.1X port-based Network Access Control
- EDID Minder® automatically manages EDID communication between connected devices
- Key Minder® continuously verifies HDCP compliance for quick, reliable switching
- HDCP Visual Confirmation
- Compatible with CATx shielded twisted pair cable
- Integrates with Pro Series control systems for secure, user-friendly external control
- CEC – Consumer Electronics Control capability
- IP Link Secure Platform Ports for extended Extron Pro Series Control of RS-232, IR, and Digital I/O
- Multicast filtering with IGMPv2/v3
- One-button endpoint identification
- Four scaling decoders can be mounted in 1U with the optional RSB126
- 1.0" (25 mm) high, 4.3" (109 mm)

**Model**  
NAV SD 121

**Version Description**  
1G HDMI Compact Scaling Decoder

**Part Number**  
60-2040-02

# 1G COMPACT PRO AV OVER IP DECODER - HDMI

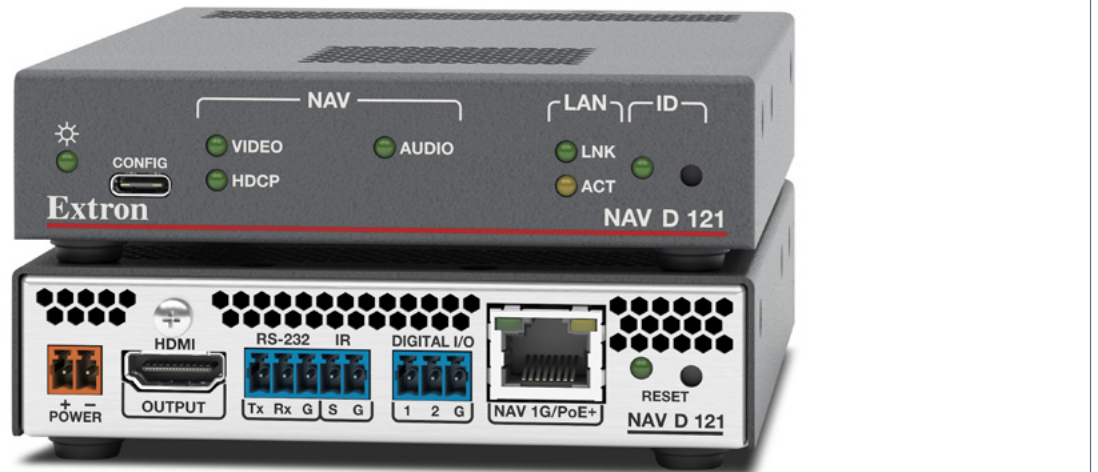

## NAV D 121

The NAV D 121 is a compact Pro AV over IP decoder that receives real-time, high-quality video and audio signals over 1Gbps IP networks at low bitrates. Utilizing Extron's patented PURE3<sup>®</sup> codec, it delivers groundbreaking performance with high quality video at resolutions up to 4K/60 with 4:4:4 chroma sampling and ultra-low latency. The NAV D 121 is compatible with NAV<sup>®</sup> endpoints, increasing scalability for large deployments. It also features an HDMI output with RS-232, Digital I/O, and IR ports to extend control system reach beyond the physical location of the processor, eliminating the need for additional control processors at the endpoints. Purpose-built to support demanding professional AV applications, the highly scalable and powerful NAV platform enables secure deployment of AV signals to thousands of endpoints.

### Features

- Compact, economical video and audio decoding, distribution, and switching over an industry standard 1 Gbps copper Ethernet interface
- HDMI output at resolutions up to 4K/60 with 4:4:4 chroma sampling
- Extron-patented PURE3<sup>®</sup> codec capable of lossless 4K/60 4:4:4 video with ultra-low latency
- PURE3 error concealment delivers high immunity to network errors without adding latency
- Confidence Preview of the encoder video is available in either the endpoint or NAVigator browser interface
- Configurable Power Priority selects PoE or line power priority for power management and redundancy
- Interoperable with 1 and 10 Gbps NAV encoders
- HDCP 2.3 compliant
- SRTP stream encryption
- Audio breakaway enables independent audio and video switching
- SRTP stream encryption
- Customizable Screen Saver
- Priority Routing
- Active Directory support
- Adjustable bit rate
- Embedded browser interface
- 802.1X port-based Network Access Control
- EDID Minder<sup>®</sup> automatically manages EDID communication between connected devices
- Key Minder<sup>®</sup> continuously verifies HDCP compliance for quick, reliable switching
- HDCP Visual Confirmation
- Compatible with CATx shielded twisted pair cable
- Integrates with Pro Series control systems for secure, user-friendly external control
- CEC – Consumer Electronics Control capability
- IP Link Secure Platform Ports for extended Extron Pro Series Control of RS-232, IR, and Digital I/O
- Multicast filtering with IGMPv2/v3
- One-button endpoint identification
- Four decoders can be mounted in 1U with the optional RSB126
- 1.0" (25 mm) high, 4.3" (109 mm) wide quarter rack width metal enclosure, 6.0" (152 mm) deep

| Model     | Version Description     | Part Number |
|-----------|-------------------------|-------------|
| NAV D 121 | 1G HDMI Compact Decoder | 60-2040-03  |



**NAV**  
PRO AVoIP

**DTP3**  
SYSTEMS

## NAV E 111 DTP3

The NAV E 111 DTP3 is a Pro AV over IP encoder that receives video, audio, and control signals from Extron DTP3 or DTP transmitters over up to 330 feet of shielded CATx cable, and streams ultra-low latency, high quality content over standard Gigabit IP networks. The Extron patented PURE3® codec delivers groundbreaking performance with high quality video at resolutions up to 4K @ 60 Hz with 4:4:4 chroma sampling and ultra-low latency. The NAV E 111 DTP3 is fully compatible with NAV 1 and 10 Gbps decoders, increasing range, scalability, and flexibility of deployments. Support for embedded digital HDMI and AES67 audio over IP facilitates flexible integration with DMP 128 Plus DSPs or other IP-enabled audio components. The NAV E 111 DTP3 is purpose-built to support demanding professional AV applications, the highly scalable and powerful NAV platform enables secure deployment of AV signals to thousands of endpoints.

### Features

- Converts, encodes, and streams video, audio, and control signals from DTP3/DTP transmitters over 1 Gbps IP networks
- Supports resolutions up to 4K/60 @ 4:4:4
- PURE3 Codec with lossless, ultra-low latency video
- PURE3 Intelligent Selective Streaming for efficient bit rates
- PURE3 error concealment for network resilience
- Interoperable with 10 Gbps NAV decoders
- AES67 audio in or out support
- HDCP 2.3 compliant
- SRTP stream encryption
- Audio breakaway enables independent audio and video switching
- SRTP stream encryption
- Customizable Screen Saver
- Priority Routing
- Active Directory support
- Adjustable bit rate
- HDMI loop-through
- Embedded browser interface
- 802.1X port-based Network Access Control
- HDMI loop-through local display or confidence monitor
- EDID Minder® automatically manages EDID communication between connected devices
- Key Minder® continuously verifies HDCP compliance for quick, reliable switching
- HDCP Visual Confirmation
- Extron XTP DTP 24 shielded twisted pair cable is strongly recommended for optimal performance
- Compatible with CATx shielded twisted pair cable
- Remote powering of select DTP3 or DTP transmitters
- RJ-45 signal and link LED indicators for DTP3 port
- CEC – Consumer Electronics Control
- Multicast filtering with IGMPv2/v3
- One-button endpoint identification
- Department of Defense Information Network Approved Product version available - DoDIN APL.
- Internal Extron Everlast Power Supply is covered by a 7-year parts and labor warranty
- 1.66 (4.2 cm) high, half rack width metal enclosure

| Model          | Version Description                       | Part Number |
|----------------|---|-------------|
| NAV E 111 DTP3 | 1G Pro AV over IP Encoder with DTP3 Input | 60-1525-16  |

## NAV E 101 and NAV SD 101

The NAV E 101 and NAV SD 101 are a Pro AV over IP encoder and scaling decoder that deliver ultra-low latency, visually lossless video and audio signals over 1 Gbps IP networks at low bit rates. The Extron patented PURE3® codec delivers groundbreaking performance with real-time, high-quality video at resolutions up to 4K @ 60 Hz with 4:4:4 chroma sampling. The NAV E 101 and NAV SD 101 are fully compatible with NAV 10 Gbps endpoints, increasing flexibility and scalability of deployments. Support for analog, embedded digital HDMI audio and AES67 Audio Over IP facilitate flexible integration with DMP 128 Plus audio DSP processors or other IP enabled audio components. Purpose-built to support demanding professional AV applications, the highly scalable and powerful NAV platform enables secure deployment of AV signals to thousands of endpoints. The NAV E 101 and NAV SD 101 are fully integrated with Extron Pro Series control systems to create powerful, flexible, and easy to use Pro AV over IP systems.

### Features

- Streams video and audio over a 1 Gbps Ethernet interface to IP networks
- Supports HDMI 2.0 at resolutions up to 4K/60 @ 4:4:4 chroma
- PURE3 Codec with lossless, ultra-low latency video
- PURE3 Intelligent Selective Streaming for efficient bit rates
- PURE3 error concealment
- Interoperable with 10 Gbps NAV endpoints
- AES67 audio support for flexible DSP integration
- HDCP 2.3 compliant
- HDCP Visual Confirmation
- PoE+ compatibility eliminates the need for a local power supply
- SRTP stream encryption
- Audio breakaway enables independent audio and video switching
- Customizable Screen Saver
- Priority Routing
- Active Directory support
- 802.1X port-based Network Access Control
- WindowWall® Mode supports videowall applications
- NAV SmartGlide™ KVM Workstation capability
- Embedded browser interface
- EDID Minder® automatically manages EDID communication between connected devices
- Key Minder® continuously verifies HDCP compliance for quick, reliable switching
- Supports analog and embedded HDMI audio signals
- IP Link Secure Platform Ports such as RS-232, IR, and Tally extended Extron Pro Series Control Systems to the endpoint.
- CEC – Consumer Electronics Control
- Multicast filtering with IGMPv2/v3
- One-button endpoint identification
- External Extron Everlast™ power supply included and covered by a 7-year parts and labor warranty
- 1" (2.5 cm) high, half rack width metal enclosure



### NAV E 101

1G Pro AV Over IP Encoder - HDMI

#### Unique Features

- HDMI 2.0 at resolutions up to 4K/60 @ 4:4:4 chroma sampling
- Visually lossless video with ultra-low latency over 1 Gbps IP network
- HDMI loop-through
- Extron Pro Series control system integration with SPD extension
- Digital, analog, and AES67 audio with breakaway capability
- Secure, 802.1X, AES encrypted, and FIPS 140-2 verified

### NAV SD 101

1G Pro AV over IP Scaling Decoder - HDMI

#### Unique Features

- Advanced Extron Vector™ 4K scaling technology
- WindowWall® Mode supports videowall applications
- Extron Pro Series control system integration with SPD extension
- Digital, analog, and AES67 audio with breakaway capability
- Secure, 802.1X, AES encrypted, and FIPS 140-2 verified

| Model     | Version Description | Part Number |
|-----------|---------------------|-------------|
| NAV E 101 | 1G HDMI Encoder     | 60-1525-12  |

| Model      | Version Description     | Part Number |
|------------|-------------------------|-------------|
| NAV SD 101 | 1G HDMI Scaling Decoder | 60-1525-14  |

# 1G PRO AV OVER IP - HDMI, ETHERNET, AND USB

## NAV E 501 and NAV SD 501

The NAV E 501 and NAV SD 501 are a Pro AV over IP encoder and scaling decoder that deliver ultra-low latency, visually lossless video, audio, USB, and Ethernet signals over 1 Gbps IP networks at low bitrates. The Extron patented PURE3® codec delivers groundbreaking performance with real-time, high quality video at resolutions up to 4K @ 60 Hz with 4:4:4 chroma sampling. The NAV E 501 and NAV SD 501 are fully compatible with NAV 10 Gbps endpoints, increasing flexibility and scalability of deployments. Support for analog and embedded digital HDMI audio and AES67 Audio Over IP facilitate flexible integration with DMP 128 Plus audio DSP processors or other IP enabled audio components. These 500 Series endpoints also deliver USB 2.0 extension and switching, along with Ethernet expansion. Purpose-built to support demanding professional AV applications, the highly scalable and powerful NAV platform enables secure deployment of AV signals to thousands of endpoints.

### Features

- Streams video, audio, USB, and Ethernet over 1 Gbps IP networks
- Supports HDMI 2.0 at resolutions up to 4K/60 @ 4:4:4 chroma
- PURE3 Codec with lossless, ultra-low latency video
- PURE3 Intelligent Selective Streaming for efficient bit rates
- PURE3 error concealment
- Interoperable with 10 Gbps NAV endpoints
- AES67 audio support for flexible DSP integration
- USB 2.0 extension
- Ethernet expansion
- HDCP 2.3 compliant
- HDCP Visual Confirmation
- PoE+ compatibility eliminates the need for a local power supply
- SRTP stream encryption
- Audio breakaway enables independent audio and video switching
- Customizable Screen Saver
- Priority Routing
- 802.1X port-based Network Access Control
- WindoWall® Mode supports videowall applications
- NAV SmartGlide™ KVM Workstation capability
- Embedded browser interface
- EDID Minder® automatically manages EDID communication between connected devices
- Key Minder® continuously verifies HDCP compliance for quick, reliable switching
- Supports analog and embedded HDMI audio signals
- Secure Platform Device for extended Extron Pro Series Control
- IP Link Secure Platform Ports such as RS-232, IR, and Tally extended Extron Pro Series Control Systems to the endpoint.
- CEC – Consumer Electronics Control capability
- Multicast filtering with IGMPv2/v3
- One-button endpoint identification
- Active Directory support
- Department of Defense Information Network Approved Product version available - DoDIN APL.
- External Extron Everlast™ power supply included and covered by a 7-year parts and labor warranty
- 1" (2.5 cm) high, half rack width metal enclosure



### NAV E 501

1G Pro AV Over IP Encoder - HDMI, Ethernet, and USB

#### Unique Features

- NAV SmartGlide™ KVM Workstation capability
- USB 2.0 extension
- Ethernet expansion
- HDMI 2.0 at resolutions up to 4K/60 @ 4:4:4 chroma sampling
- Visually lossless video with ultra-low latency over 1 Gbps IP network
- HDMI loop-through
- Extron Pro Series control system integration with SPD extension
- Secure, 802.1X, AES encrypted, and FIPS 140-2 verified

| Model     | Version Description            | Part Number |
|-----------|--------------------------------|-------------|
| NAV E 501 | 1G HDMI, Ethernet, USB Encoder | 60-1525-01  |



### NAV SD 501

1G Pro AV over IP Scaling Decoder - HDMI, Ethernet, and USB

#### Unique Features

- Advanced Extron Vector™ 4K scaling technology
- WindoWall® Mode supports videowall applications
- NAV SmartGlide™ KVM Workstation capability
- USB 2.0 extension
- Ethernet expansion
- Extron Pro Series control system integration with SPD extension
- Digital, analog, and AES67 audio with breakaway capability
- Secure, 802.1X, AES encrypted, and FIPS 140-2 verified

| Model      | Version Description                    | Part Number |
|------------|--|-------------|
| NAV SD 501 | 1G HDMI, Ethernet, USB Scaling Decoder | 60-1525-03  |

# 1G FIBER PRO AV OVER IP - HDMI, ETHERNET, AND USB

## NAV E 511 and NAV SD 511

The NAV E 511 and NAV SD 511 are a Pro AV over IP optical encoder and scaling decoder that deliver ultra-low latency, visually lossless video, audio, USB, and Ethernet signals over 1 Gbps optical Ethernet interface to IP networks at low bitrates. The Extron patented PURE3® codec delivers groundbreaking performance with real-time, high quality video at resolutions up to 4K @ 60 Hz with 4:4:4 chroma sampling. The NAV E 511 and NAV SD 511 are fully compatible with NAV 10 Gbps endpoints, increasing flexibility and scalability of deployments. Support for analog and embedded digital HDMI audio and AES67 Audio Over IP facilitate flexible integration with DMP 128 Plus audio DSP processors or other IP enabled audio components. These 500 Series endpoints also deliver USB 2.0 extension and switching, along with Ethernet expansion. Purpose-built to support demanding professional AV applications, the highly scalable and powerful NAV platform enables secure deployment of AV signals to thousands of endpoints.

### Features

- Streams video, audio, USB, and Ethernet over a 1 Gbps optical Ethernet interface to IP networks
- Supports HDMI 2.0 at resolutions up to 4K/60 @ 4:4:4 chroma
- PURE3 Codec with lossless, ultra-low latency video
- PURE3 Intelligent Selective Streaming for efficient bit rates
- PURE3 error concealment
- Interoperable with 10 Gbps NAV endpoints
- AES67 audio support for flexible DSP integration
- USB 2.0 extension
- Ethernet expansion
- HDCP 2.3 compliant
- HDCP Visual Confirmation
- PoE+ compatibility eliminates the need for a local power supply
- SRTP stream encryption
- Audio breakaway enables independent audio and video switching
- Customizable Screen Saver
- Priority Routing
- 802.1X port-based Network Access Control
- WindoWall® Mode supports videowall applications
- NAV SmartGlide™ KVM Workstation capability
- Embedded browser interface
- EDID Minder® automatically manages EDID communication between connected devices
- Key Minder® continuously verifies HDCP compliance for quick, reliable switching
- Supports analog and embedded HDMI audio signals
- CEC – Consumer Electronics Control capability
- Multicast filtering with IGMPv2/v3
- Department of Defense Information Network Approved Product available
- Active Directory support
- IP Link Secure Platform Ports such as RS-232, IR, and Tally extended Extron Pro Series Control Systems to the endpoint.
- External Extron Everlast™ power supply included and covered by a 7-year parts and labor warranty
- 1" (2.5 cm) high, half rack width metal enclosure



### NAV E 511

1G Fiber Pro AV Over IP Encoder - HDMI, Ethernet, and USB

#### Unique Features

- Single or multimode optical 1G Ethernet interface up to 10km from the switch
- Adjustable bit rate
- Visually lossless 4K/60 4:4:4 video with ultra-low latency
- NAV SmartGlide™ KVM Workstation capability
- USB 2.0 extension
- Ethernet expansion

### NAV SD 511

1G Fiber Pro AV over IP Scaling Decoder - HDMI, Ethernet, and USB

#### Unique Features

- Single or multimode optical 1G Ethernet interface up to 10km from the switch
- Advanced Extron Vector™ 4K scaling technology
- WindoWall® Mode supports videowall applications
- NAV SmartGlide™ KVM Workstation capability
- USB 2.0 extension
- Ethernet expansion

| Model     | Version Description                          | Part Number |
|-----------|--|-------------|
| NAV E 511 | 10G HDMI, Ethernet, USB Encoder - Multimode  | 60-1958-05  |
| NAV E 511 | 10G HDMI, Ethernet, USB Encoder - Singlemode | 60-1958-06  |

| Model      | Version Description                                | Part Number |
|------------|--|-------------|
| NAV SD 511 | 10G HDMI, Ethernet, USB Scaling Decoder-Multimode  | 60-1958-07  |
| NAV SD 511 | 10G HDMI, Ethernet, USB Scaling Decoder-Singlemode | 60-1958-08  |

# 1G PRO AV OVER IP WALLPLATE - HDMI AND ETHERNET

## NAV E 201 D and NAV E 401 D

The NAV E 201 D and NAV E 401 D are Pro AV over IP encoders in a decorator-style wallplate package, that deliver ultralow latency, visually lossless video, audio, and Ethernet signals over 1 Gbps IP networks at low bitrates. The Extron patented PURE3® codec delivers groundbreaking performance with real-time, high quality video at resolutions up to 4K @ 60 Hz with 4:4:4 chroma sampling. The NAV E 201 D and NAV E 401 D are fully compatible with NAV 10 Gbps decoders, increasing flexibility and scalability of deployments. Support for embedded digital HDMI audio and AES67 Audio Over IP facilitate flexible integration with DMP 128 Plus audio DSP processors or other IP enabled audio components. The NAV E 401 D also provides Ethernet expansion capability. Purpose-built to support demanding professional AV applications, the highly scalable and powerful NAV platform enables secure deployment of AV signals to thousands of endpoints.

### Features

- Streams video, audio, and Ethernet over 1 Gbps IP networks
- Supports HDMI 2.0 at resolutions up to 4K/60 @ 4:4:4 chroma
- PURE3 Codec with lossless, ultra-low latency video
- PURE3 Intelligent Selective Streaming for efficient bit rates
- PURE3 error concealment
- Interoperable with 10 Gbps NAV endpoints
- AES67 audio support for flexible DSP integration
- HDCP 2.3 compliant
- HDCP Visual Confirmation
- PoE+ compatibility eliminates the need for a local power supply
- SRTP stream encryption
- Audio breakaway enables independent audio and video switching
- Priority Routing
- 802.1X port-based Network Access Control
- Embedded browser interface
- EDID Minder® automatically manages EDID communication between connected devices
- Key Minder® continuously verifies HDCP compliance for quick, reliable switching
- IP Link Secure Platform Ports such as RS-232 and IR extended Extron Pro Series Control Systems to the endpoint
- CEC – Consumer Electronics Control capability
- Multicast filtering with IGMPv2/v3
- One-button endpoint identification
- Active Directory support
- Department of Defense Information Network Approved Product version available - DoDIN APL
- External Extron Everlast™ power supply included and covered by a 7-year parts and labor warranty



### NAV E 201 D

1G Pro AV Over IP Encoder - HDMI

#### Unique Features

- Decorator-style wallplate provides convenience and security
- Adjustable bit rate
- HDMI 2.0 at resolutions up to 4K/60 @ 4:4:4 chroma sampling
- Visually lossless video with ultra-low latency over 1 Gbps IP network
- HDMI loop-through
- Extron Pro Series control system integration with SPD extension
- Secure, 802.1X, AES encrypted, and FIPS 140-2 verified

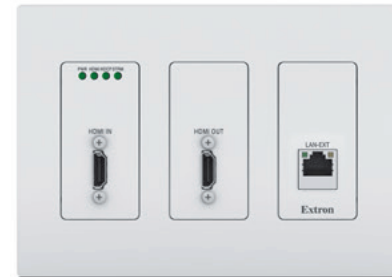

### NAV E 401 D

1G Pro AV over IP Encoder - HDMI and Ethernet

#### Unique Features

- Decorator-style wallplate provides convenience and security
- Ethernet expansion
- Adjustable bit rate
- HDMI 2.0 at resolutions up to 4K/60 @ 4:4:4 chroma sampling
- Visually lossless video with ultra-low latency over 1 Gbps IP network
- HDMI loop-through
- Extron Pro Series control system integration with SPD extension
- Secure, 802.1X, AES encrypted, and FIPS 140-2 verified

| Model       | Version Description               | Part Number |
|-------------|-----------------------------------|-------------|
| NAV E 201 D | 1G HDMI Encoder - Decorator White | 60-1525-06  |
| NAV E 201 D | 1G HDMI Encoder - Decorator Black | 60-1525-05  |

| Model       | Version Description                        | Part Number |
|-------------|--|-------------|
| NAV E 401 D | 1G HDMI Ethernet Encoder - Decorator White | 60-1525-08  |
| NAV E 401 D | 1G HDMI Ethernet Encoder - Decorator Black | 60-1525-07  |

# 10G PRO AV OVER IP WALLPLATE - HDMI AND ETHERNET

## NAV 10E 201 D and NAV 10E 401 D

The NAV 10E 201 D and NAV 10E 401 D are Pro AV over IP encoders in a decorator-style wallplate package, that deliver ultra-low latency, lossless video, audio, and Ethernet signals over 10 Gbps IP networks at low bitrates. The Extron patented PURE3® codec delivers groundbreaking performance with real-time, high quality video at resolutions up to 4K @ 60 Hz with 4:4:4 chroma sampling. The NAV 10E 201 D and NAV 10E 401 D are fully compatible with NAV 1 Gbps decoders, increasing flexibility and scalability of deployments. Support for embedded digital HDMI audio and AES67 Audio Over IP facilitate flexible integration with DMP 128 Plus audio DSP processors or other IP enabled audio components. The NAV 10E 401 D also provides Ethernet expansion capability. Purpose-built to support demanding professional AV applications, the highly scalable and powerful NAV platform enables secure deployment of AV signals to thousands of endpoints.

### Features

- Streams video, audio, and Ethernet over 10 Gbps IP networks
- Supports HDMI 2.0 at resolutions up to 4K/60 @ 4:4:4 chroma
- PURE3 Codec with lossless, ultra-low latency video
- PURE3 Intelligent Selective Streaming for efficient bit rates
- PURE3 error concealment
- Interoperable with 1 Gbps NAV endpoints
- AES67 audio support for flexible DSP integration
- HDCP 2.3 compliant
- HDCP Visual Confirmation
- SRTP stream encryption
- Audio breakaway enables independent audio and video switching
- Priority Routing
- 802.1X port-based Network Access Control
- Embedded browser interface
- EDID Minder® automatically manages EDID communication between connected devices
- Key Minder® continuously verifies HDCP compliance for quick, reliable switching
- IP Link Secure Platform Ports such as RS-232 and IR extended Extron Pro Series Control Systems to the endpoint.
- CEC – Consumer Electronics Control
- Multicast filtering with IGMPv2/v3
- One-button endpoint identification
- Active Directory support
- Department of Defense Information Network Approved Product version available - DoDIN APL
- External Extron Everlast™ power supply included and covered by a 7-year parts and labor warranty



## NAV 10E 201 D

10G Pro AV Over IP Encoder - HDMI

### Unique Features

- Decorator-style wallplate provides convenience and security
- Single or multimode optical 10G Ethernet interface up to 10km from the switch
- Adjustable bit rate
- HDMI 2.0 at resolutions up to 4K/60 @ 4:4:4 chroma sampling
- Lossless video with ultra-low latency over 10 Gbps IP network
- HDMI loop-through
- Extron Pro Series control system integration with SPD extension
- Secure, 802.1X, AES encrypted, and FIPS 140-2 verified

## NAV 10E 401 D

10G Pro AV over IP Encoder - HDMI and Ethernet

### Unique Features

- Decorator-style wallplate provides convenience and security
- Single or multimode optical 10G Ethernet interface up to 10km from the switch
- Ethernet expansion
- Adjustable bit rate
- HDMI 2.0 at resolutions up to 4K/60 @ 4:4:4 chroma sampling
- Lossless video with ultra-low latency over 10 Gbps IP network
- HDMI loop-through
- Extron Pro Series control system integration with SPD extension
- Secure, 802.1X, AES encrypted, and FIPS 140-2 verified

| Model        | Version Description                     | Part Number |
|--------------|---|-------------|
| NAV 10E 201D | 10G HDMI Encoder - Decorator White - SM | 60-1572-24  |
| NAV 10E 201D | 10G HDMI Encoder - Decorator White - MM | 60-1572-23  |
| NAV 10E 201D | 10G HDMI Encoder - Decorator Black - SM | 60-1572-22  |
| NAV 10E 201D | 10G HDMI Encoder - Decorator Black - MM | 60-1572-21  |

| Model         | Version Description                               | Part Number |
|---------------|---|-------------|
| NAV 10E 401 D | 10G HDMI, Ethernet Encoder - Decorator White - SM | 60-1572-28  |
| NAV 10E 401 D | 10G HDMI, Ethernet Encoder - Decorator White - MM | 60-1572-27  |
| NAV 10E 401 D | 10G HDMI, Ethernet Encoder - Decorator Black - SM | 60-1572-26  |
| NAV 10E 401 D | 10G HDMI, Ethernet Encoder - Decorator Black - MM | 60-1572-25  |

# 10G PRO AV OVER IP - HDMI

## NAV 10E 101 and NAV 10SD 101

The NAV 10E 101 and NAV 10SD 101 are an Pro AV over IP optical encoder and scaling decoder that deliver ultra-low latency, lossless video and audio signals over 10 Gbps optical Ethernet interface to IP networks at low bit rates. The Extron patented PURE3® codec delivers groundbreaking performance with real-time, high quality video at resolutions up to 4K @ 60 Hz with 4:4:4 chroma sampling. The NAV 10E 101 and NAV 10SD 101 are fully compatible with NAV 1 Gbps endpoints, increasing flexibility and scalability of deployments. Support for analog and embedded digital HDMI audio and AES67 Audio Over IP facilitate flexible integration with DMP 128 Plus audio DSP processors or other IP enabled audio components. Purpose-built to support demanding professional AV applications, the highly scalable and powerful NAV platform enables secure deployment of AV signals to thousands of endpoints.

### Features

- Streams video and audio over a 10 Gbps optical Ethernet interface to IP networks
- Single or multimode optical 10G Ethernet interface up to 10km
- Supports HDMI 2.0 at resolutions up to 4K/60 @ 4:4:4 chroma
- PURE3 Codec with lossless, ultra-low latency video
- PURE3 Intelligent Selective Streaming for efficient bit rates
- PURE3 error concealment
- Interoperable with 1 Gbps NAV endpoints
- AES67 audio support for flexible DSP integration
- HDCP 2.3 compliant
- PoE+ compatibility eliminates the need for a local power supply
- SRTP stream encryption
- Audio breakaway enables independent audio and video switching
- Customizable Screen Saver
- Priority Routing
- Active Directory support
- 802.1X port-based Network Access Control
- WindoWall® Mode supports videowall applications
- NAV SmartGlide™ KVM Workstation capability
- Embedded browser interface
- EDID Minder® automatically manages EDID communication between connected devices
- Key Minder® continuously verifies HDCP compliance for quick, reliable switching
- HDCP Visual Confirmation
- Supports analog and embedded HDMI audio signals
- IP Link Secure Platform Ports such as RS-232, IR, and Tally extended Extron Pro Series Control Systems to the endpoint.
- CEC – Consumer Electronics Control
- Multicast filtering with IGMPv2/v3
- One-button endpoint identification
- Department of Defense Information Network Approved Product version available - DoDIN APL.
- External Extron Everlast™ power supply included and covered by a 7-year parts and labor warranty
- 1" (2.5 cm) high, half rack width metal enclosure



### NAV 10E 101

10G Pro AV Over IP Encoder - HDMI

#### Unique Features

- Single or multimode optical 10G Ethernet interface up to 10km from the switch
- HDMI 2.0 at resolutions up to 4K/60 @ 4:4:4 chroma sampling
- Adjustable bit rate
- Lossless video with ultra-low latency over 10 Gbps IP networks
- Extron Pro Series control system integration with SPD extension
- Digital, analog, and AES67 audio with breakaway capability
- Secure, 802.1X, AES encrypted, and FIPS 140-2 verified

### NAV 10SD 101

10G Pro AV over IP Scaling Decoder - HDMI

#### Unique Features

- Single or multimode optical 10G Ethernet interface up to 10km from the switch
- Advanced Extron Vector™ 4K scaling technology
- WindoWall® Mode supports videowall applications
- Extron Pro Series control system integration with SPD extension
- Digital, analog, and AES67 audio with breakaway capability
- Secure, 802.1X, AES encrypted, and FIPS 140-2 verified

| Model       | Version Description           | Part Number |
|-------------|-------------------------------|-------------|
| NAV 10E 101 | 10G HDMI Encoder - Multimode  | 60-1572-15  |
| NAV 10E 101 | 10G HDMI Encoder - Singlemode | 60-1572-16  |

| Model        | Version Description                   | Part Number |
|--------------|---------------------------------------|-------------|
| NAV 10SD 101 | 10G HDMI Scaling Decoder - Multimode  | 60-1572-19  |
| NAV 10SD 101 | 10G HDMI Scaling Decoder - Singlemode | 60-1572-20  |

# 10G PRO AV OVER IP - HDMI, ETHERNET, AND USB

## NAV 10E 501 and NAV 10SD 501

The NAV 10E 501 and NAV 10SD 501 are an AV over IP optical encoder and scaling decoder that deliver ultra-low latency, lossless video, audio, USB, and Ethernet signals over 10 Gbps optical Ethernet interface to IP networks at low bitrates. The Extron patented PURE3® codec delivers groundbreaking performance with real-time, high quality video at resolutions up to 4K @ 60 Hz with 4:4:4 chroma sampling. The NAV 10E 501 and NAV 10SD 501 are fully compatible with NAV 1 Gbps endpoints, increasing flexibility and scalability of deployments. Support for analog and embedded digital HDMI audio and AES67 Audio Over IP facilitate flexible integration with DMP 128 Plus audio DSP processors or other IP enabled audio components. These 500 Series endpoints also deliver USB 2.0 extension and switching, along with Ethernet expansion. Purpose-built to support demanding professional AV applications, the highly scalable and powerful NAV platform enables secure deployment of AV signals to thousands of endpoints.

### Features

- Streams video, audio, USB, and Ethernet over a 10 Gbps optical
- Ethernet interface to IP networks
- Single or multimode optical 10G Ethernet interface up to 10km
- Supports HDMI 2.0 at resolutions up to 4K/60 @ 4:4:4 chroma
- PURE3 Codec with lossless, ultra-low latency video
- PURE3 Intelligent Selective Streaming for efficient bit rates
- PURE3 error concealment
- Interoperable with 1 Gbps NAV endpoints
- AES67 audio support for flexible DSP integration
- USB 2.0 extension
- Ethernet expansion
- HDCP 2.3 compliant
- PoE+ compatibility eliminates the need for a local power supply
- SRTP stream encryption
- Audio breakaway enables independent audio and video switching
- Customizable Screen Saver
- Priority Routing
- 802.1X port-based Network Access Control
- WindoWall® Mode supports videowall applications
- NAV SmartGlide™ KVM Workstation capability
- Embedded browser interface
- EDID Minder® automatically manages EDID communication between connected devices
- Key Minder® continuously verifies HDCP compliance for quick, reliable switching
- HDCP Visual Confirmation
- Supports analog and embedded HDMI audio signals
- IP Link Secure Platform Ports such as RS-232, IR, and Tally extended Extron Pro Series Control Systems to the endpoint.
- CEC – Consumer Electronics Control
- Multicast filtering with IGMPv2/v3
- One-button endpoint identification
- Active Directory support
- Department of Defense Information Network Approved Product version available - DoDIN APL.
- External Extron Everlast™ power supply included and covered by a 7-year parts and labor warranty
- 1" (2.5 cm) high, half rack width metal enclosure



### NAV 10E 501

10G Pro AV Over IP Encoder - HDMI, Ethernet, and USB

#### Unique Features

- Single or multimode optical 10G Ethernet interface up to 10km from the switch
- Adjustable bit rate
- Lossless 4K/60 4:4:4 video with ultra-low latency
- NAV SmartGlide™ KVM Workstation capability
- USB 2.0 extension
- Ethernet expansion

### NAV 10SD 501

10G Pro AV over IP Scaling Decoder - HDMI, Ethernet, and USB

#### Unique Features

- Single or multimode optical 10G Ethernet interface up to 10km from the switch
- Advanced Extron Vector™ 4K scaling technology
- WindoWall® Mode supports videowall applications
- NAV SmartGlide™ KVM Workstation capability
- USB 2.0 extension
- Ethernet expansion

| Model       | Version Description                          | Part Number |
|-------------|--|-------------|
| NAV 10E 501 | 10G HDMI, Ethernet, USB Encoder - Multimode  | 60-1572-01  |
| NAV 10E 501 | 10G HDMI, Ethernet, USB Encoder - Singlemode | 60-1572-02  |

| Model        | Version Description                                | Part Number |
|--------------|--|-------------|
| NAV 10SD 501 | 10G HDMI, Ethernet, USB Scaling Decoder-Multimode  | 60-1572-07  |
| NAV 10SD 501 | 10G HDMI, Ethernet, USB Scaling Decoder-Singlemode | 60-1572-08  |

# NETWORKING

Successful deployment of Pro AV Over IP applications requires some networking proficiency. Extron certification programs prepare integrators to successfully deploy and troubleshoot networked AV systems. For more information about the Extron **Network AV Specialist** certification program for NAV, please see the certifications page toward the back of this document.

When deploying Pro AV over IP, it's important to be familiar with the following key terms:

**Multicast** - Multicast is a “one-to-many” form of group communication where a single data stream is addressed to a group of destinations simultaneously. It is considerably more efficient, significantly reducing bandwidth required over Unicast, a “many-to-many” form of group communication, where a separate stream is sent to each endpoint.

**IGMP** - Internet Group Management Protocol, or IGMP, is a network layer (Layer 3) protocol used to establish membership in a **Multicast** group. IGMP manages multicast group memberships by marking packets in messages sent between a router and the hosts. Each sending host applies a unique identifier to multicast packets so that they can be identified, then separated or forwarded as required.

**IGMP Snooping** - Most network switches are Layer 2 devices operating on the link layer of the OSI protocol. Since Layer 2 devices are typically unaware of IP addresses and the IGMP protocol, they cannot filter multicast packets. With IGMP snooping, Layer 2 devices, such as a switch, can listen to IGMP queries and configure Layer 2 LAN ports to selectively forward multicast traffic to only the ports that should receive it.

For more detailed information, please refer to the Extron

**Multicast for AV Streaming** whitepaper available at: [www.extron.com/multicastpaper](http://www.extron.com/multicastpaper).

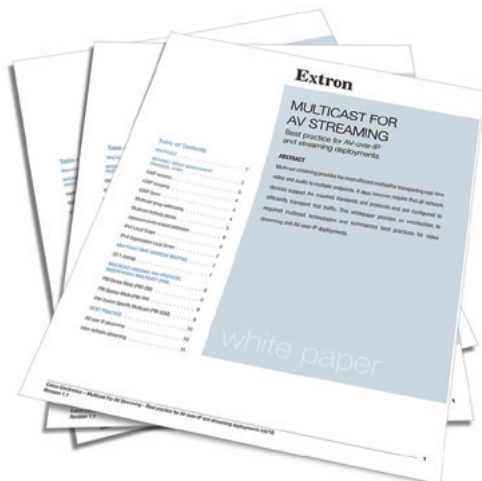

## NETWORK DESIGN SUPPORT

To ensure optimal performance and reliability, a team of Extron networking experts are available to provide personalized assistance with network design and selecting the right network equipment for your unique application.

**For more information, contact your Extron representative.**

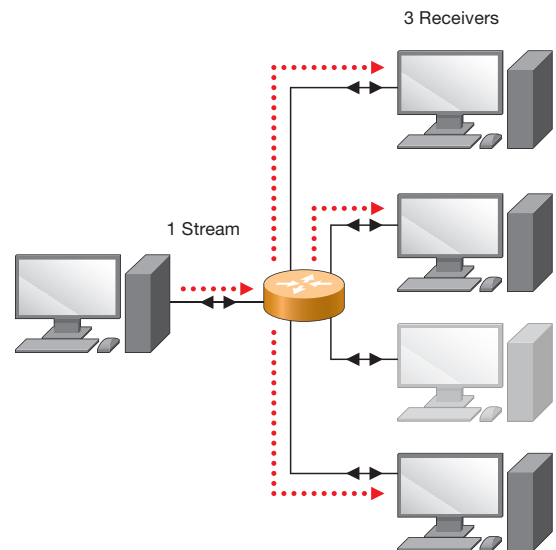

**Multicast “one-to-many” streaming, where a single stream is delivered to multiple endpoints, significantly conserving bandwidth**

# VALIDATED SWITCHES

The Extron Network Technologies Support Group works with industry-leading network switch manufacturers to validate their switches to ensure they work flawlessly in your next Extron Pro AV over IP application. Only switches that pass our extensive testing program make our list of Validated Switches. System designers are assured that every switch on our Validated Switches list has been rigorously evaluated and tested to work together with the Extron NAV Pro AVoIP Series to ensure optimum compatibility. This ensures consistent and reliable operation, which simplifies integration and reduces the need for troubleshooting.

Extron also offers setup guides that will walk you through network switch settings, streamlining the frequently tedious task of switch configuration, so that you can spend more time focusing on the other parts of the installation. Additionally, our team of dedicated networking experts can provide the information you need to communicate clearly with IT departments for seamless network integration.

## VALIDATED SWITCHES

Our Network Technologies Support Group brings together an unparalleled team of senior AV engineers that specialize in Enterprise IT Network Management. We are here to assist you from pre-sales conceptual design to post-sale commissioning, ensuring that your NAV deployment meets your every expectation.

**ARISTA**

**JUNIPER**  
NETWORKS

  
**CISCO**

 **Extreme**  
networks

 **barox**

**aruba**  
a Hewlett Packard  
Enterprise company

**NETGEAR**

**FORTINET**



**D-Link**

COMMSCOPE  
**RUCKUS**

The Validated Switches List can be found on any NAV product page. Simply click on the "Validated Switches" button on the right side of the screen and you will see the most up-to-date list of switches which can be sorted and filtered to easily find the right switch for your application.

## LECTURE PRESENTATION SPACE

In lecture spaces the NAV E 222 USB-C and HDMI Switching Encoder enables flexible input options to distribute and switch ultra-low latency, high-quality video, audio, and control signals over standard 1 Gbps IP network. With the optional UPI 100 Power Inserter the NAV E 222 supplies up to 100 Watts of power to the connected USB-C video source. The HDMI input is used to present content from the document camera, and a confidence monitor allows the presenter to confirm content before being switched to the NAV SD 121 Compact Scaling Decoders with Vector 4K Scaling mounted discretely behind each display. These scaling decoders provide consistently flawless presentation of varying input resolutions.

The content source may be selected automatically, with the NAV E 222 front panel buttons, or graphically with the TLP Pro 725M at the lectern working with an IPCP Pro 255Q xi Quad Core Control Processor and NAVigator System Manager to automate AV system functions.

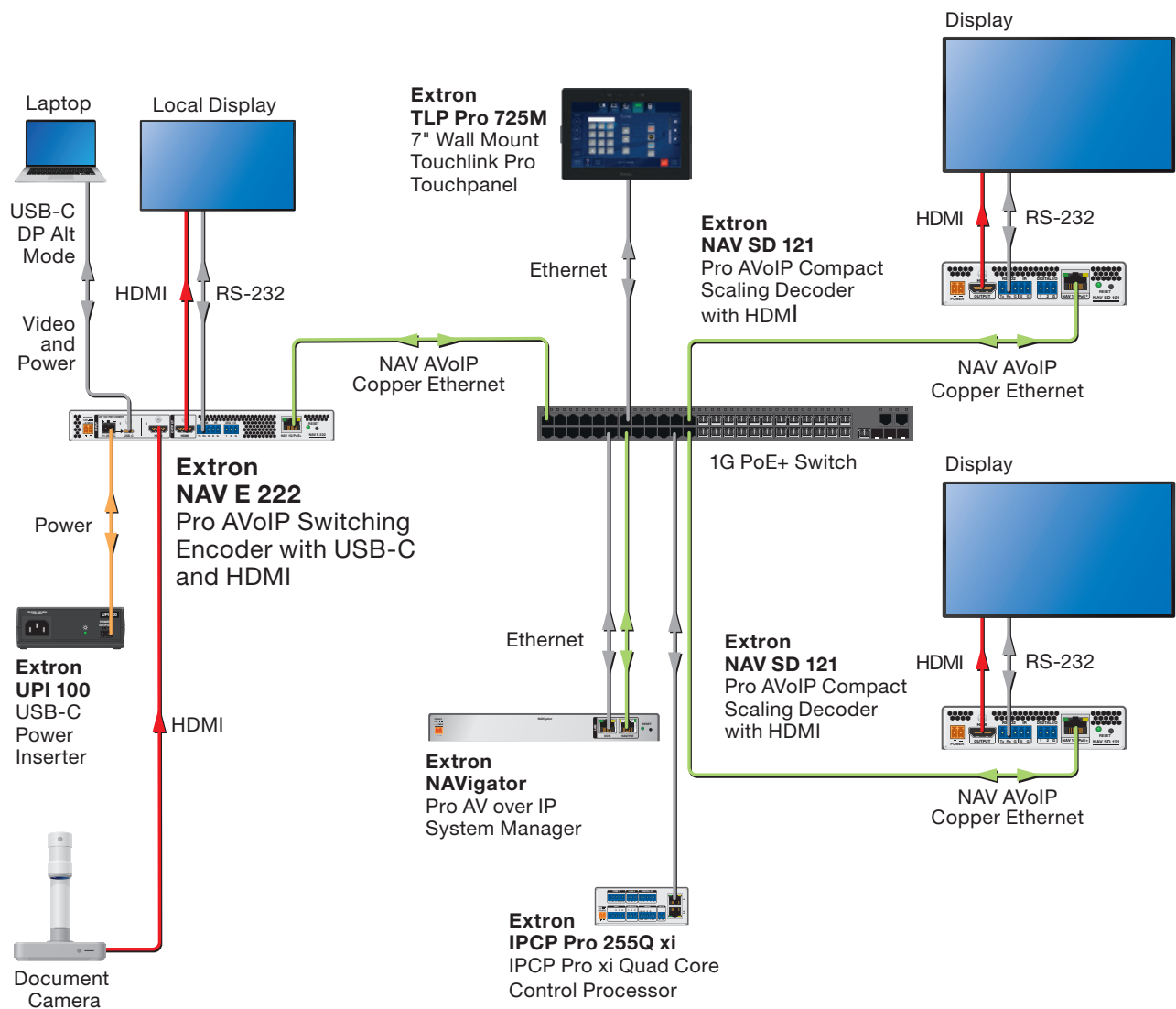

## BRING YOUR OWN USB-C LAPTOP PRESENTATION WITH FIXED PC ASSETS

The NAV Pro AV over IP System supports a variety of interfaces and compatibility between 1 and 10 Gbps endpoints, and the NAV E 111 DTP3 combines both the NAV and DTP3 award winning technologies. A fixed in room PC/Server with HDMI video out and a BYO laptop with USB-C DP alt-mode connect to a DTP3 T 212 D two input wall plate transmitter located up to 330' (100m) from the NAV E 111 DTP3 encoder. The encoder displays the selected source on the confidence monitor and streams visually lossless, ultra-low latency video over a standard IP network to any NAV decoder. The NAV SD 121 Compact Scaling Decoder, NAV 10SD 101 - 10 Gbps Optical Scaling Decoder and the NAV SD 511 - 1 Gbps Optical Scaling Decoder all with HDMI output and RS-232 IPLink Secure Platform Interfaces, are mounted discretely behind the displays and deliver perfect Vector 4K Scaling presentation and control.

A TouchLink Pro 725 touchpanel working with an IPCP Pro 255Q xi Quad Core Control Processor and NAVigator System Manager provides convenient input switching routing and distribution of video up to 4K60 with 4:4:4 chroma sampling to any and all displays.

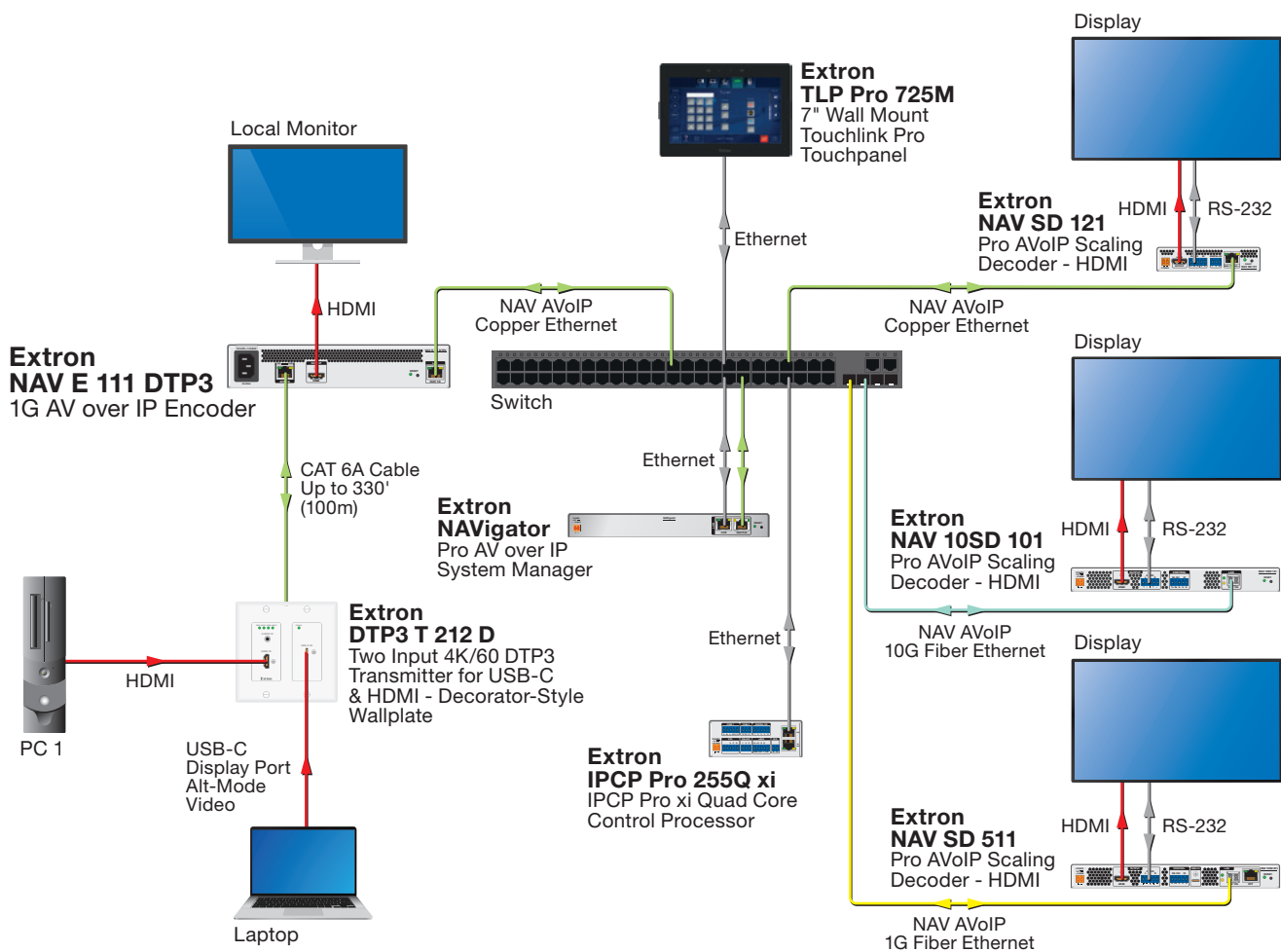

## ACTIVE LEARNING SPACE

The NAV Pro AV over IP System enables flexible instructor led and collaborative education for active learning spaces. Each station is equipped with a NAV E 121 Compact Encoder with a WPD 100 A for HDMI input and a NAV SD 121 Compact Scaling Decoder behind each display for flawless Vector 4K Scaling of varying input resolutions. The instructor lectern is also equipped with a ShareLink Pro 2500 4K Wireless Presentation System for wired and wireless collaboration and a TouchLink Pro 725 touchpanel for convenient control of all classroom content.

A remote, control room also has a TouchLink Pro 725 touchpanel, along with a shared IPCP Pro 255Q xi Quad Core Control Processor and NAVigator System Manager that work together to support and manage AV system functions. The control room also has a streaming receiver connected to a NAV E 121 as a shared resource to stream content to any classroom display and future expansion rooms and a NAV SD 121 to support the active learning space.

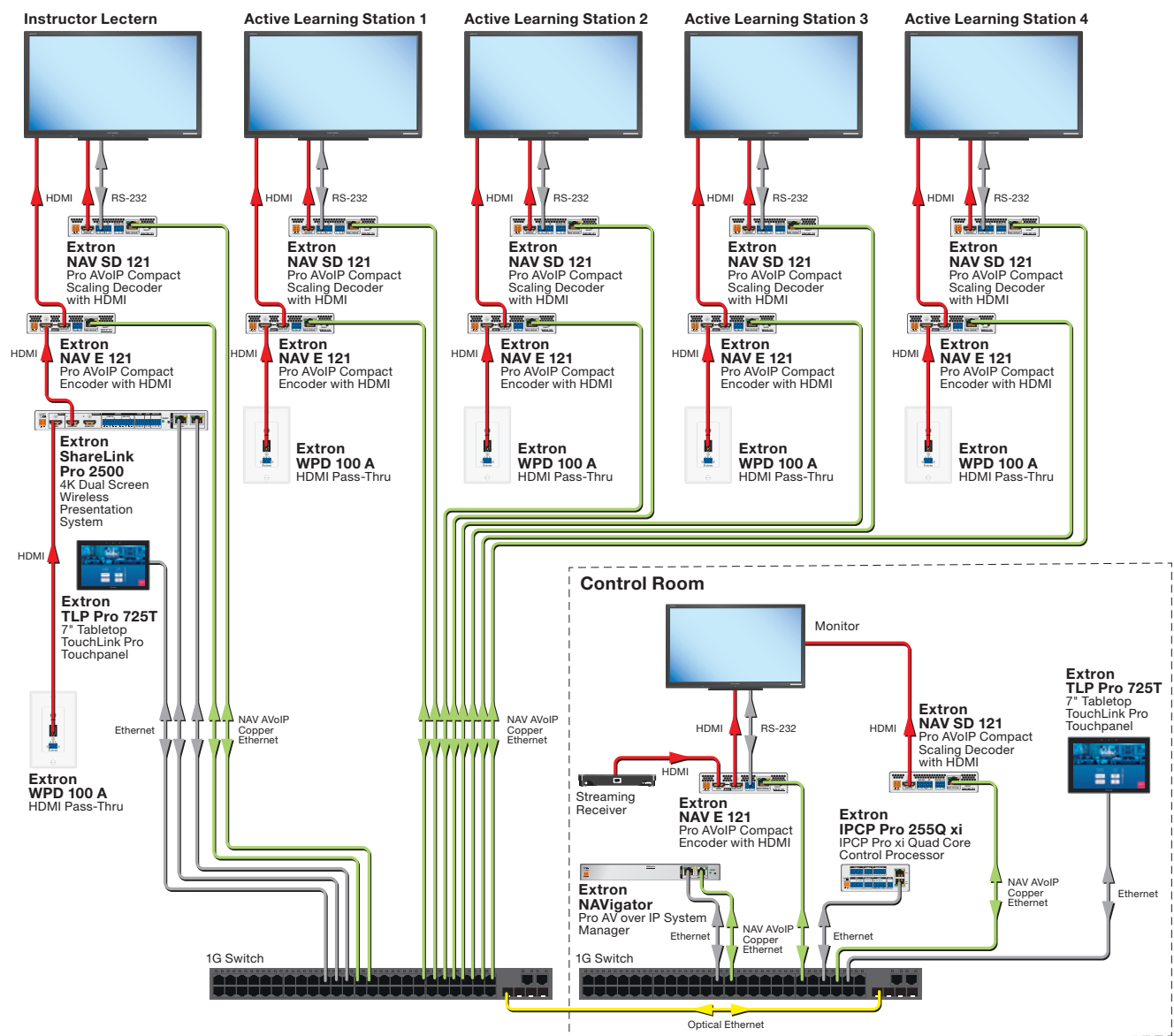

## FLEXIBLE LEARNING SPACE

In flexible learning spaces NAV Series Pro AV over IP is used to distribute and switch ultra-low latency, high-quality video, audio, and control signals over the school's existing 1 Gbps IP network. The content source may be selected by a TLP Pro 725M at the primary stand or lectern working with an IPCP Pro 255Q xi Quad Core Control Processor and NAVigator in the control room to automate AV system functions. The primary AV stand originates content from an HDMI input or the ShareLink Pro 2500 with Miracast that is used to share wireless BYOD content. This is viewed locally on the primary stand display through the NAV E 121 HDMI loop-thru and may be distributed over multicast IP to all other primary and secondary stands, and overflow rooms throughout campus. In overflow rooms, NAV SD 511 scaling decoder provides Ethernet expansion to a NetPA U 1002-70V power amplifier with DSP that supports NAV AES67 audio streaming. SF 26 CT two-way ceiling speakers accurately reproduce audio. Shared resources such as a streaming receiver connected to a NAV E 121 encoder in the control room or a camera connected to a NAV E 511 encoder in the administrative office may also be shared live over the multicast IP network to all NAV scaling decoders. A TLP Pro 1225TG Touchpanel in the administrative office, with an HDMI input enables both control and confidence monitoring. This may be used for campus wide meetings, or to broadcast emergency information to all learning spaces.

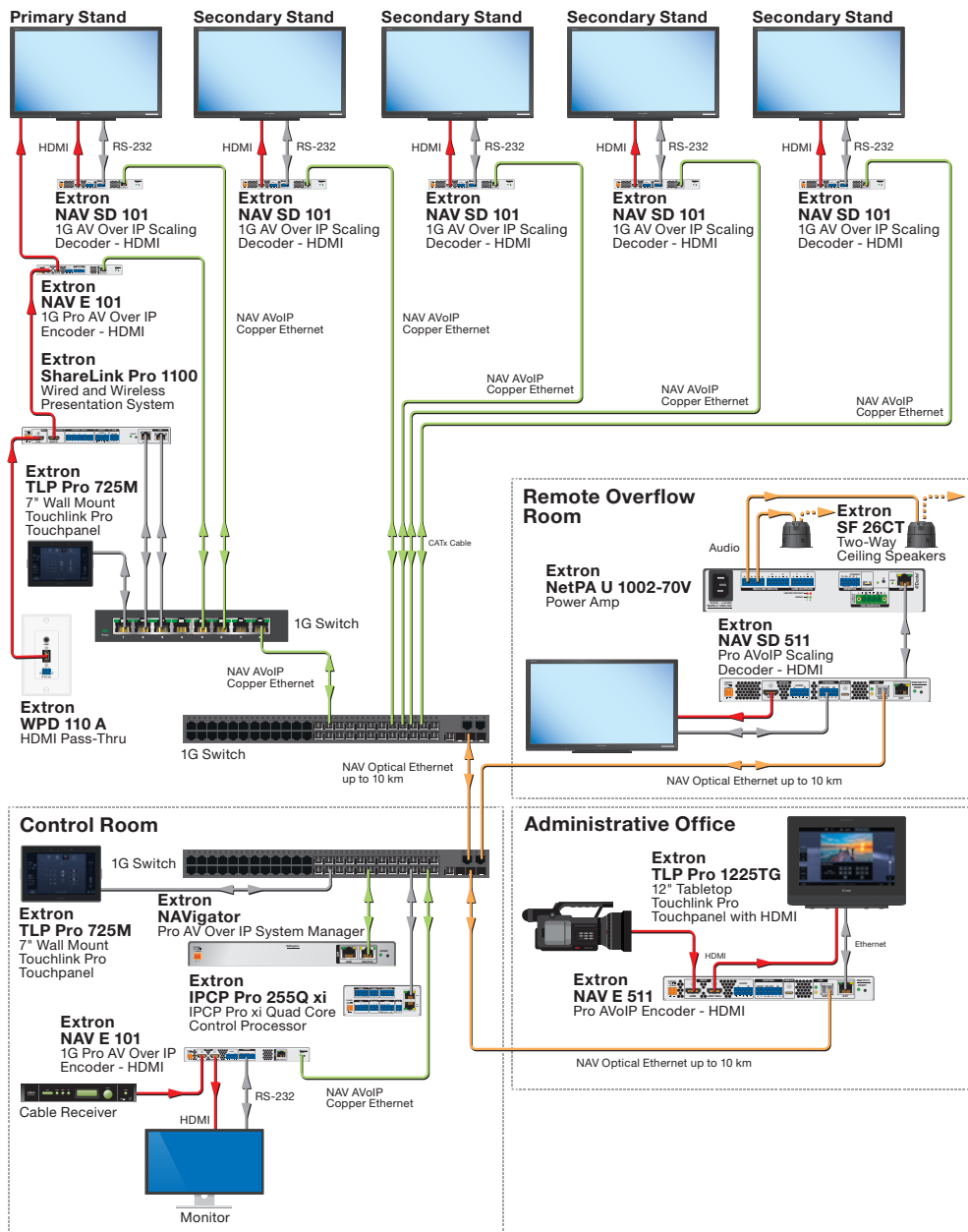

## OPERATIONS CENTER WITH WINDOWALL AND SMARTGLIDE KVM WORKSTATION

An equipment room houses four racked computers, each connected to a NAV E 501 encoder with HDMI, USB, and Ethernet. Eight displays in a 2 X 4 array are each connected to NAV SD 121 Compact Scaling Decoders to create a NAV WindoWall® videowall. Additionally, four displays in a 1 X 4 arrangement are each connected to NAV scaling decoders forming a NAV SmartGlide™ KVM Workstation. A keyboard and mouse is connected to a NAV SD 501 Scaling Decoder with USB, as part of a NAV SmartGlide KVM – Keyboard, Video, and Mouse Workstation. Three NAV SD 121 Compact Scaling Decoders are also connected as part of this 1 X 4 workstation. SmartGlide KVM switching enables automatic, fast KVM switching as the mouse glides from display to display with no noticeable latency. The optional SmartGlide KVM Focus can optionally highlight the currently active display. A TLP Pro 725T Tabletop TouchLink Pro Touchpanel along with an IPCP Pro 255Q xi IP Link Pro Control Processor and a NAVigator System Manager enable convenient and secure control of the WindoWall.

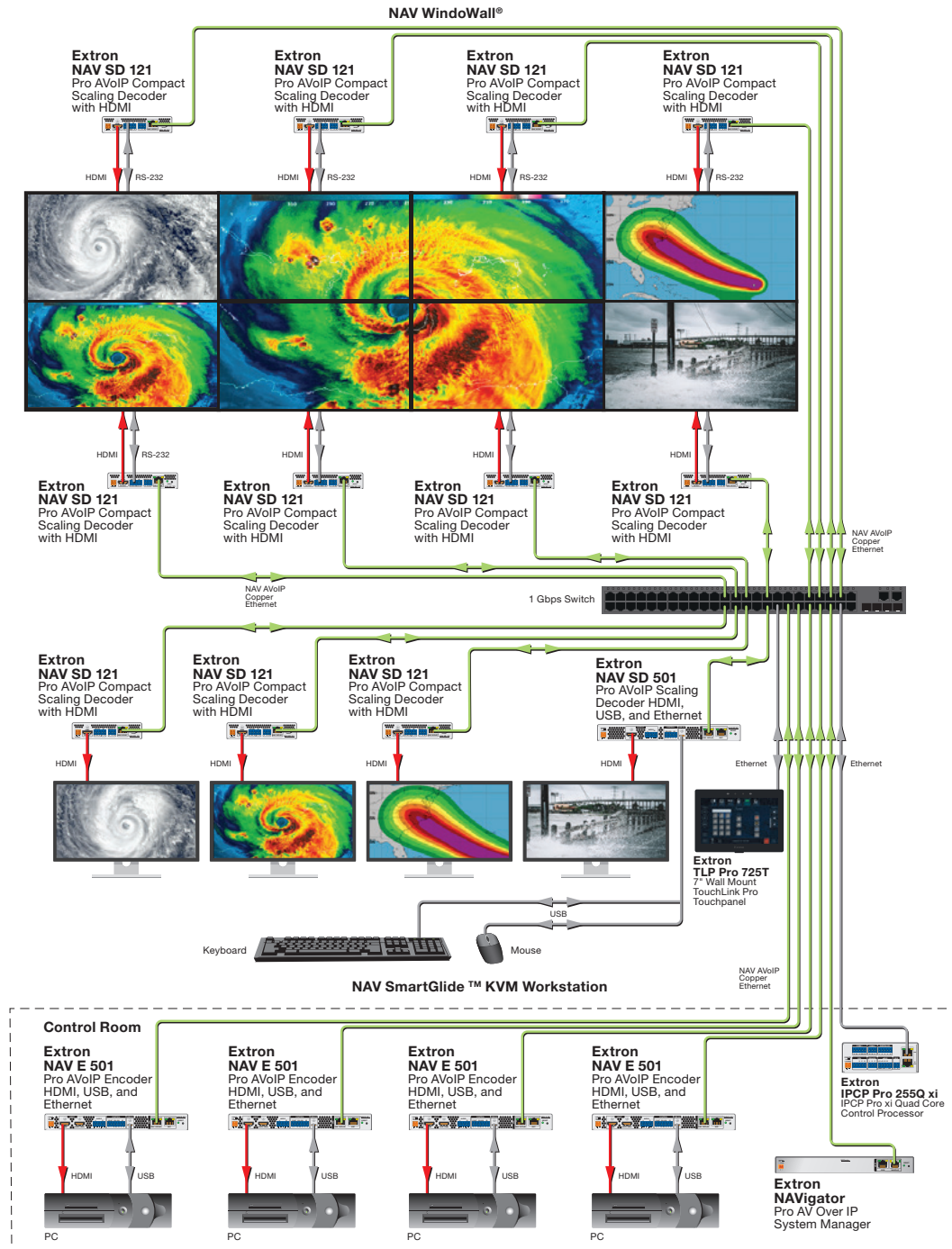

## SURGICAL TRAINING

The Control Room houses PCs connected via HDMI to NAV E 121 Compact Encoders that stream visually lossless images and data over a 1Gbps IP network. Other NAV E 121 Compact Encoders accept HDMI input from operating room cameras and a BYOD laptop. NAV SD 121 Compact Scaling Decoders connect via HDMI to a 2 x 3 WindoWall® videowall in the observation room and displays in the operating room. An Extron TLP Pro 1225TG Wall Mount TouchLink Pro Touchpanel connects to a NAV SD 121 Compact Scaling Decoder to preview sources and works with a IPCP Pro 255Q xi and a NAVigator System Manager to control and switch content to the operating room displays and the observation room WindoWall.

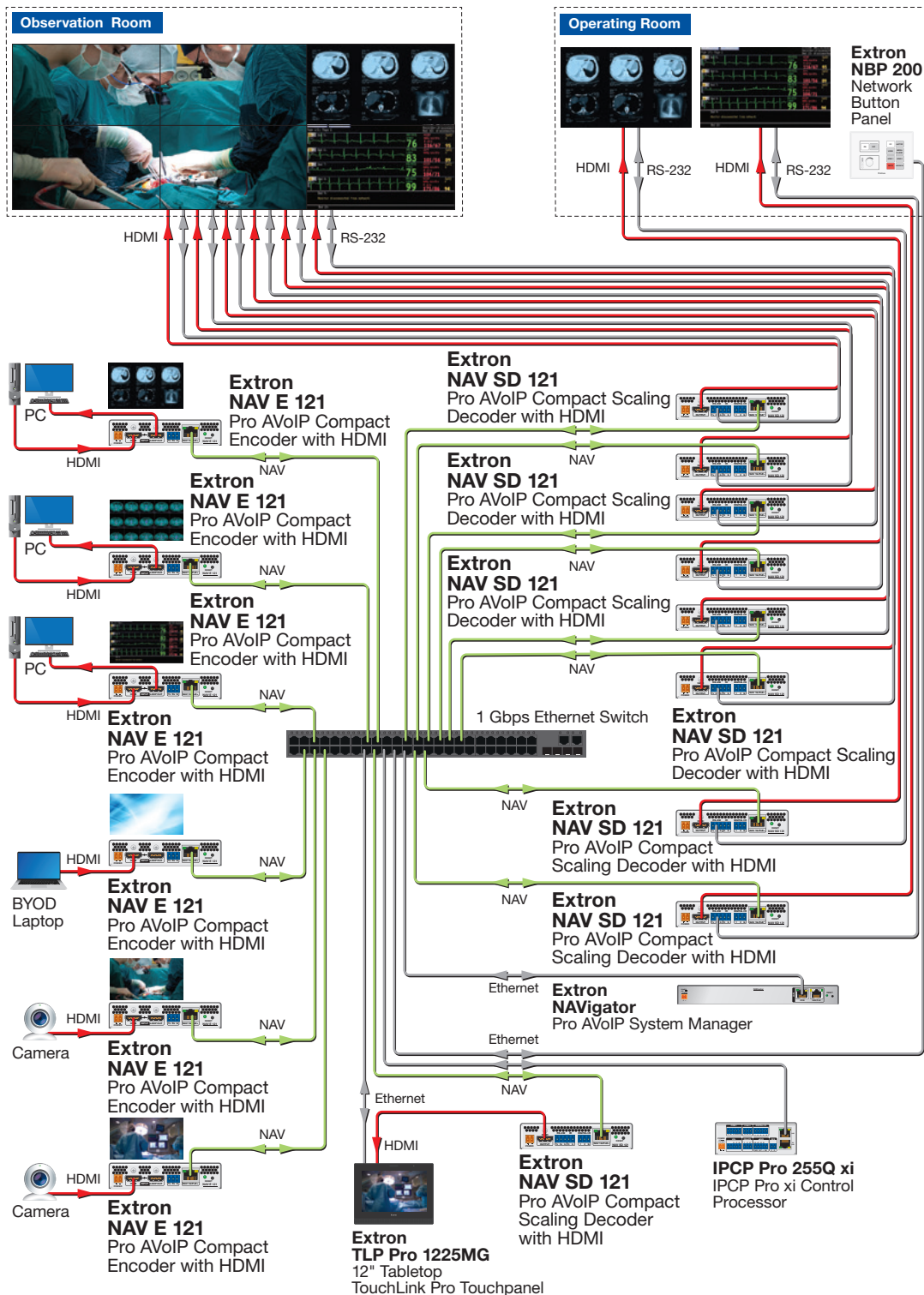

## CLASSROOM LECTURE CAPTURE WITH SHARED MATERIALS

The NAV Pro AV over IP System integrated with an SMP 401 enables additional PC or server-based materials to be integrated into the classroom lecture. A NAV E 121 Compact Encoder provides content from a classroom PC, and a NAV D 121 Compact Decoder delivers that content to the SMP 401. The instructor lectern is also equipped with a and a TouchLink Pro 725 touchpanel integrated with an IPCP Pro 255Q xi Quad Core Control Processor and NAVigator System Manager for convenient control of all classroom content.

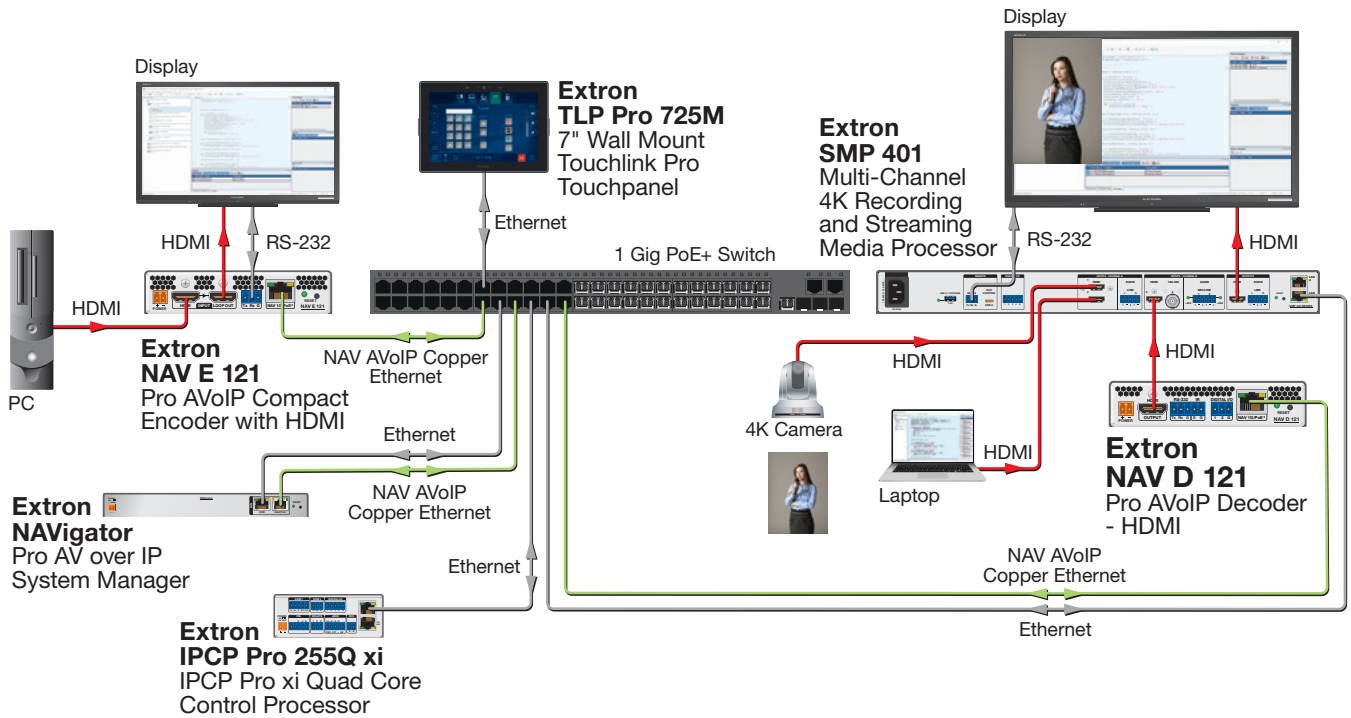

# NETWORK TECHNOLOGIES SUPPORT GROUP



## Advanced Expertise That Ensures Success

Extron is known for our award-winning commitment to the highest standards in quality, service, and support, and we continuously evolve to meet the changing needs of the industry and our customers. We are the only AV manufacturer with a team of exceptionally talented, dedicated experts focused on making your NAV AV over IP deployment a success.

Our Network Technologies Support Group brings together an unparalleled team of senior AV engineers specializing in Enterprise IT Network Management. With certifications such as CCNP and CCIE our team is here to assist you, from pre-sales and conceptual designs to post-sale commissioning, ensuring that your NAV deployment meets your needs and exceeds your expectations.

Our team of experts provides the insight and guidance you need to communicate clearly with IT departments for seamless network integration. We work to make sure you are completely satisfied with every installation - guaranteed. Our support engineers are readily available and easily accessible worldwide.

### SERVICES INCLUDE:

- Pre-sales support
- Network design validation
- Network switch validation
- Installation support
- Commissioning support
- Troubleshooting

## Compatibility You Can Trust



The Network Technologies Support Group also works with industry-leading network switch manufacturers to ensure they work flawlessly in your next NAV Pro AV over IP application. Only switches that pass our extensive testing program make our list of Validated Switches. System designers are assured that every switch on our Validated Switches list has been rigorously tested to work together with the Extron NAV Pro AV over IP Series to ensure optimum compatibility. This provides consistent and reliable operation, which simplifies integration and reduces the need for troubleshooting. Extron also offers setup guides that will walk you through network switch settings, streamlining the complicated and confusing task of switch configuration, so that you can spend more time focusing on the other parts of the installation.

Many leading switch manufacturers and models are included on the Validated Switches List, and the list can be accessed from any NAV product page. Simply click on the "Validated Switches" button to view the most up-to-date list of switches.





## Extron Network AV Specialist Program

The Extron Network AV Specialist - NAVS certification program prepares individuals to successfully deploy and troubleshoot networked AV systems using Extron NAV encoders, decoders, and software. Course participants will learn advanced techniques for streaming Pro AV over IP with an emphasis on low latency, bandwidth management, and signal quality. They will also learn to configure point-to-point and multipoint-to-multipoint networked AV systems and best practices for deploying Extron NAVigator, a hardware appliance for the secure management, configuration, and control of NAV Pro AV over IP systems. In addition, the Network AV Specialist program includes opportunities for hands-on experience with system configuration, validation, and troubleshooting.



### Extron Certification

In the highly competitive AV industry, education, training, and certification are important to both individual and corporate success. Like a professional license, certification instills customer confidence, providing formalized evidence of critical knowledge and skills. The fluency and expertise acquired through Extron Certification Programs save valuable time and expense, ensuring higher levels of customer service and satisfaction.

The Extron Network AV Specialist certification program is for AV professionals who wish to advance their knowledge of Pro AV over IP system technology, design, and configuration. This program features both online and instructor-led training components, providing system integrators, engineers, and

consultants an opportunity to learn new skills, validate their existing skills, and gain a better understanding of the latest technologies and solutions in growing field of Pro AV over IP.

### Course Content

The Extron Network AV Specialist program is a two-day course covering the following categories:

- Best practices for networked AV system design and deployment
- Understanding matrix switching and Pro AV over IP
- Configuration of point-to-point and multipoint-to-multipoint networked AV systems
- Overview of NAV Pro AV over IP encoders, decoders, and software
- When and how to deploy NAVigator Pro AV over IP System Manager
- Effective fault identification, troubleshooting, and commissioning of NAV systems

### How Can I Get Started?

To request enrollment in the Network AV Specialist certification program, contact your Extron Support Representative or visit [www.extron.com/training](http://www.extron.com/training).

### Continuing Education Units

The Extron Network AV Specialist certification program qualifies for Continuing Education Unit - CEU credits with a variety of established industry organizations, including AVIXA and BICSI. For more information, visit [www.extron.com/training](http://www.extron.com/training).

# Extron

[www.extron.com](http://www.extron.com) | Follow us on:  