

TLP Pro 725C

7" SERIES/2 CABLE CUBBY TOUCHLINK PRO TOUCHPANEL



The TLP Pro 725C is a 7" Series/2 Cable Cubby TouchLink® Pro Touchpanel with a flip-up touchscreen in a Cable Access Enclosure. We redesigned this latest TouchLink Pro touchpanel inside and out with a high-performance quad-core processor, eight times more memory, and a high resolution, 1024x600 capacitive touchscreen built with scratch and smudge-resistant Corning® Gorilla Glass®. The TLP Pro 725C accommodates AC 100 Series and AC+USB 200 AC power modules and Retractor Series/2 cable retraction modules, AV cables, or AAP - Architectural Adapter Plates.

- ▶ 7" capacitive flip-up touchscreen with 1024x600 resolution and 24-bit color depth
- ▶ Gorilla Glass® screen is tough, scratch, and smudge-resistant
- ▶ Faster, quad-core processing and eight times more memory
- ▶ Compatible with all IP Link Pro control processors
- ▶ Series/2 Cable Access Enclosure design offers easy access to AV, data, and power connections
- ▶ Power over Ethernet provides power and communication over a single Ethernet cable
- ▶ Built-in speaker

DESCRIPTION

The **TLP Pro 725C** is a unique, 7" TouchLink Pro touchpanel integrated into a the lid of a Series/2 Cable Cubby enclosure. It accommodates AC 100 Series and AC+USB AC power modules and Retractor Series/2 cable retraction modules, AV cables, or AAP - Architectural Adapter Plates. For fast installation a simple, integrated clamp system quickly secures the enclosure to a furniture surface without the need for additional parts or tools. It is ideal for AV applications requiring a Cable Cubby touchpanel with a customizable interface.

DIMENSIONAL DRAWINGS

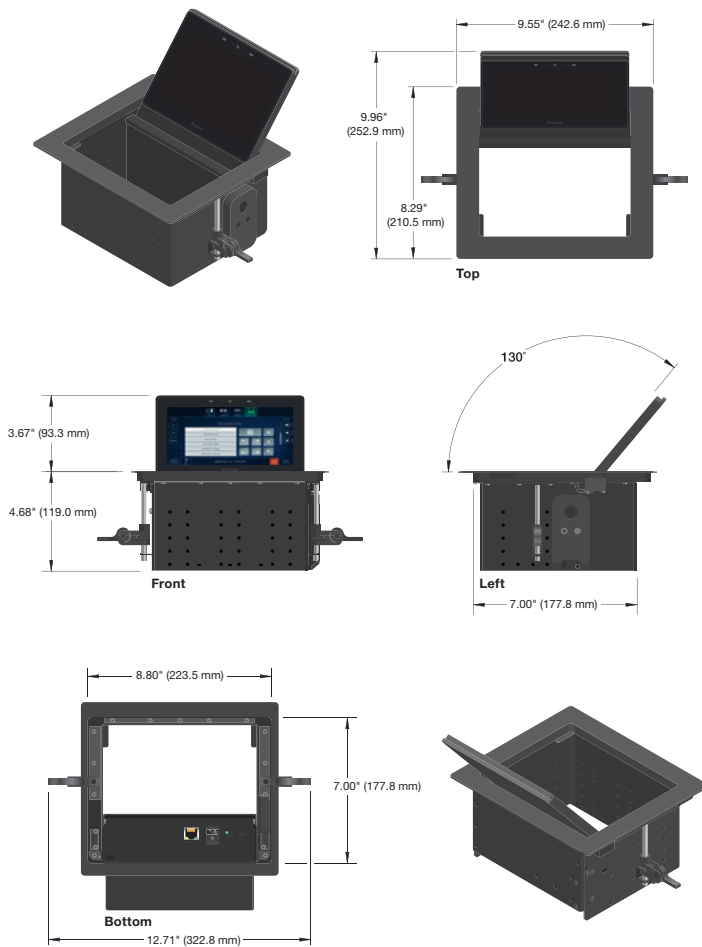

SPECIFICATIONS

DISPLAY		
Screen type	TFT Active matrix color LCD	
Size	7" (17.8 cm), measured diagonally	
Resolution	1024x600 (WSVGA)	
Aspect ratio	17:10	
Color depth	24 bit, 16.7 million colors	
Contrast	700:1	
MEMORY		
RAM	2 GB	
Storage	4 GB	
ETHERNET		
Data rate	10/100/1000Base-T, half/full duplex with autodetect	
Protocols	DHCP, DNS, HTTP, HTTPS, ICMP, SFTP, SSH, TCP/IP, UDP/IP	
SOFTWARE		
Configuration software	Global Configurator Plus and Professional, GUI Designer	
Programming software	Global Scripter	
Control apps	Extron Control, iGVE	
Resource management software	GlobalViewer Enterprise, iGVE	
Utilities	Toolbelt, Embedded web page	
Lid switch	Open/closed	
USB		
Quantity/type	1 high-speed USB 2.0 device	
USB standards	USB 2.0, USB 1.1, USB 1.0 compatible	
AUDIO OUTPUT		
Speaker output	1 mono, 89 dB Max. SPL @ 0.1 m	
Playback format(s)		
Container format	WAV (Microsoft RIFF)	
Encoding	LPCM (uncompressed)	
Audio channels	mono or stereo	
GENERAL		
Power input requirements	Power over Ethernet (PoE 802.3af, class 3)	
Temperature/humidity	Storage: -4 to +140 °F (-20 to +60°C) / 5% to 90%, noncondensing Operating: +32 to +104 °F (0 to +40 °C) / 20% to 90%, noncondensing	
Mounting	Furniture mount	
Enclosure dimensions		
ATTENTION: Use the appropriate metal Extron routing template or refer to the surface cutout dimensions here before cutting a hole in the furniture or other surface. Pay special attention to the direction the unit will face; the unit's connector access side is <u>underlined</u> . Extron is not responsible for miscut mounting holes.		
Top plate (outer rim)	<u>9.44" W</u> x 8.29" D (24.0 cm W x 21.1 cm D)	
Surface cutout (inside rim)	<u>8.80 +0.00/-0.02" W</u> x <u>7.00 +0.00/-0.02" D</u> (22.4 +0.00/-0.05 cm W x 17.8 +0.00/-0.05 cm D)	
Box (under surface)	<u>4.68" H</u> x <u>12.71" W</u> (front/rear of unit) x 7.00" D with clamps (11.9 cm H x 32.3 cm W x 17.8 cm D with clamps)	
Regulatory compliance	CE, C-tick, c-UL, FCC Class B, ICES, RoHS, UL, VCCI, WEEE	
Product warranty	3 years parts and labor; touchpanel display and overlay components are covered for 1 year	
NOTE: All nominal levels are at ±10%.		
Model	Version Description	Part number
TLP Pro 725C	Black - w/o AC Module	60-1564-02

For complete specifications, please go to www.extron.com
Specifications are subject to change without notice.

WORLDWIDE SALES OFFICES

Anaheim • Raleigh • Silicon Valley • Dallas • New York • Washington, DC • Toronto • Mexico City • Paris • London
Frankfurt • Madrid • Stockholm • Amersfoort • Moscow • Dubai • Johannesburg • Tel Aviv • Sydney • Melbourne
Bangalore • Mumbai • New Delhi • Singapore • Seoul • Shanghai • Beijing • Hong Kong • Tokyo

www.extron.com