

VECTOR 4K

S C A L I N G



Patented Scaling Technology for the
Most Demanding 4K Applications



Extron Electronics
INTERFACING, SWITCHING AND CONTROL

Extron Vector 4K Scaling Technology

For over 20 years, Extron has been engineering scaling and signal processing solutions that deliver uncompromised image quality and performance. As a result, we have become an industry leader in scaling technology, designing best-in-class products renowned for their quality, reliability, and ease of use. We have continually refined our technology to keep pace with evolving video formats – from standard definition to high definition signals, and now, 4K.

Built on our patented signal processing platforms, Vector 4K is the latest generation of Extron scaling engines, specifically engineered for critical-quality 4K signal processing. The Vector 4K scaling engine delivers the power and precision required to manage the high pixel counts of today's 4K displays and content. Whether providing clean, upscaled images when integrating legacy sources with 4K displays, or faithfully rendering a source's detail and integrity when downscaling 4K content

to HD displays, Vector 4K provides unparalleled processing and clarity for your 4K applications.

In addition to advanced video processing, Vector 4K delivers consistent, reliable performance that takes the guesswork out of signal capture and source management. Featuring the industry's most accurate source capture technology, and the ability to manually adjust image parameters with fine precision, even the most unique signal formats are displayed with speed and dependability.

Scalers and video processors with Vector 4K scaling offer a variety of convenient, user-friendly features. Aspect ratio control, dynamic vector-based test patterns, and EDID and HDCP management are just a few of the many standard product features that streamline integration and optimize system performance.

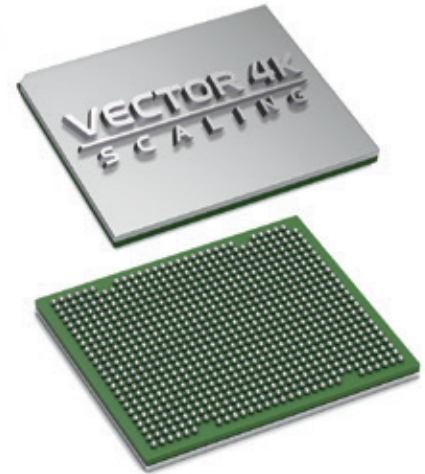

Engineered by Extron from the Ground Up

Vector 4K was developed internally by Extron's expert team of signal processing engineers. Extron engineers have crafted patented image processing technologies that set the industry benchmark for visual performance. Features such as bicubic scaling, 30-bit color depth, and 4:4:4 chroma sampling ensure very high image quality while preserving detail present in the original source material.

By developing our own scaling technology, we can design to our own exacting specifications and have absolute control over the end product. We can continually refine the signal processing algorithms, enhance signal compatibility and add features at will. This also allows us to quickly respond to market or technology-related advancements as they emerge and opens the way to accommodate application-specific requests from AV integrators.

Extron's scaling engines and sophisticated video processing algorithms have been recognized worldwide with 24 patents.

Extron Video Testing Facility



Extron DTP CrossPoint 4K Matrix with Vector 4K Scaling



Scaling Features



UNPARALLELED SCALING QUALITY

The Vector 4K scaling engine incorporates Extron-engineered, multi-tap, bicubic interpolation, which creates a new pixel by averaging adjacent pixels above, below, to the sides, and diagonally of the new pixel. This produces sharp, accurate output, preserving single-pixel detail that other scaling methods lack. Vector 4K algorithms continually and dynamically adapt, ensuring optimal processing for upscaling, downscaling, or 1:1 pass-through applications. Two less robust alternatives to bicubic interpolation are “nearest neighbor interpolation,” whereby a pixel is duplicated to an adjacent pixel, and “bilinear interpolation,” which creates a new pixel by averaging adjacent pixels above, below, and to the sides of the pixel being created. Both of these methods can produce substandard output, resulting in data loss that may render the content unusable.

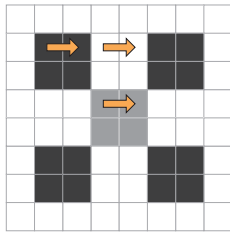

Nearest Neighbor

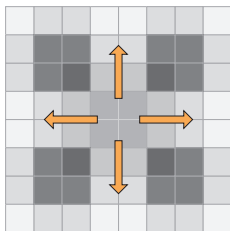

Bilinear Interpolation

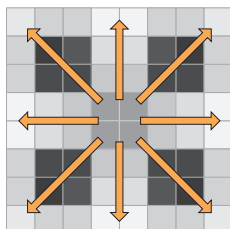

Bicubic Interpolation

4:4:4 CHROMA SAMPLING

Vector 4K processing is always performed in the RGB domain with full 4:4:4 color sampling, which is critical for processing fine image details such as single pixel, colored lines and text in computer content. Competing scalars commonly process in the YCbCr, or component domain, employing 4:2:2 or 4:2:0 chroma subsampling. This decreases the bandwidth required to process the signal, at the expense of reduced color detail. Chroma subsampling may be acceptable when processing full-motion video content, but with PC-generated content, subsampled color can negatively impact the clarity of the image. Vector 4K 4:4:4 color processing retains the fine color details present in the original source.

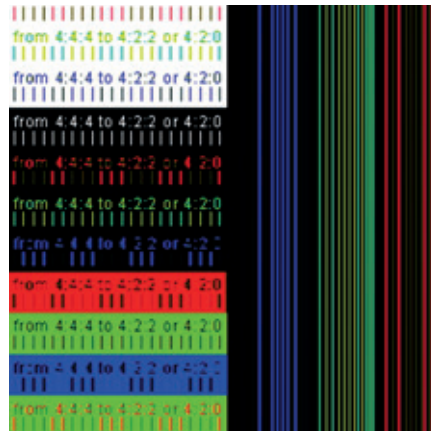

4:2:2

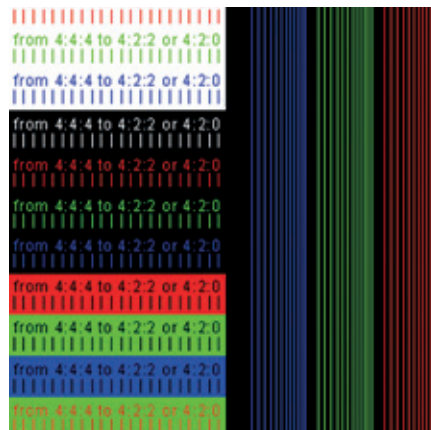

4:4:4

30-BIT COLOR DEPTH

Vector 4K video processing is performed at 30 bits per pixel to maximize grayscale and color accuracy. This maintains color fidelity and detail present in native 30-bit source content, and is a minimum requirement for supporting the BT.2020 color standard for 4K. Competitive products may accept and output content at 30-bits, but the internal processing is often limited to 24-bits per pixel or less, truncating 20% or more of the color information. Extron 30-bit processing minimizes visible color gradients by preserving all of the 30-bit source content, while delivering better color accuracy for 24-bit sources, because the additional bit depth avoids mathematical rounding errors inherent in competing 24 or 16-bit scalars and signal processors.

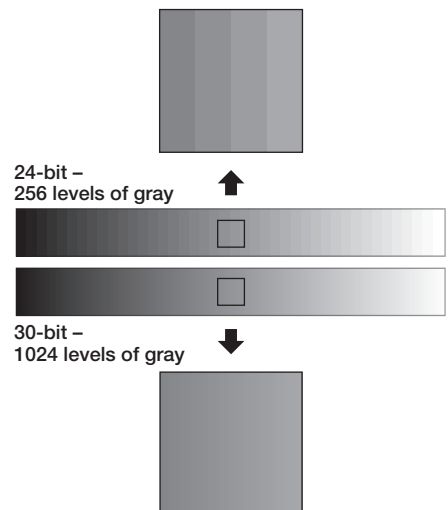

For more information about Vector 4K visit www.extron.com/vector4k



MOTION-ADAPTIVE DEINTERLACING

For the highest quality conversion from interlaced to progressive video, Extron Vector 4K scaling features patented motion-adaptive deinterlacing which integrates two different processing techniques per video frame. Blended odd and even fields are best for static content, while line doubling is optimal for areas of motion between fields. To best apply these two modes, Vector 4K utilizes motion estimation at the single-pixel level for the greatest accuracy in detecting dynamic content. Though complex and computationally intensive, this method allows interlaced motion to be averaged to avoid artifacts, while static areas are blended to perfectly preserve the original detail. Alternative deinterlacing approaches may apply only one method of deinterlacing, and simple motion-adaptive techniques only evaluate motion in regions rather than individual pixels.



Blend Method

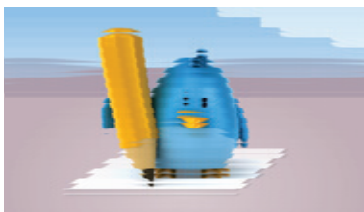

Line Doubling

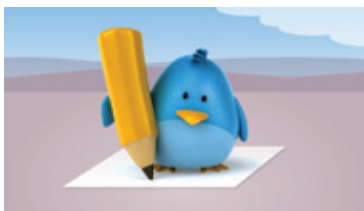

Extron Motion-Adaptive Deinterlacing

FRAME RATE CONVERSION

Vector 4K processing includes high performance frame rate conversion that always delivers images free of visual motion artifacts. In addition to eliminating on-screen video tear, frame rate conversion avoids the need for a display to readjust to changes in source frame rates, which eliminates re-syncing and minimizes latency when switching between sources. Converting from one frame rate to another is common in professional AV applications, such as converting 1080p/60 Hz content to 30 Hz for videoconferencing or streaming, or a 1080i/59.94 Hz broadcast signal to a PC rate of 1080p/60 Hz. Many scalers and signal processors on the market do not offer the capability to convert frame rates, which results in glitches, muted output, and video tear when switching between source signals.

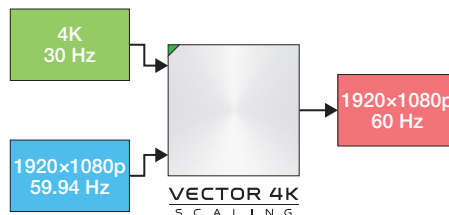

AUTOMATIC FILM CADENCE DETECTION

A particular challenge in video processing is delivering accurate reproduction of film content that has been converted to interlaced video. Vector 4K features 3:2, 2:2, and 24:1 cadence detection which examines interlaced signals and instantaneously identifies, within a fraction of a second, content that originated from 24 Hz source material. Repeated fields, generated during the 3:2, 2:2, or 24:1 pull-down process, are discarded to recreate the original, progressive 24 frame-per-second content, removing any degradation due to the interlaced transmission. Frame rate conversion is then applied to the reconstructed 24 Hz content to match the scaler's selected output frame rate. Extron's patented processing noticeably improves sharpness and detail while retaining original film grain, which more closely recreates the appearance of film content.

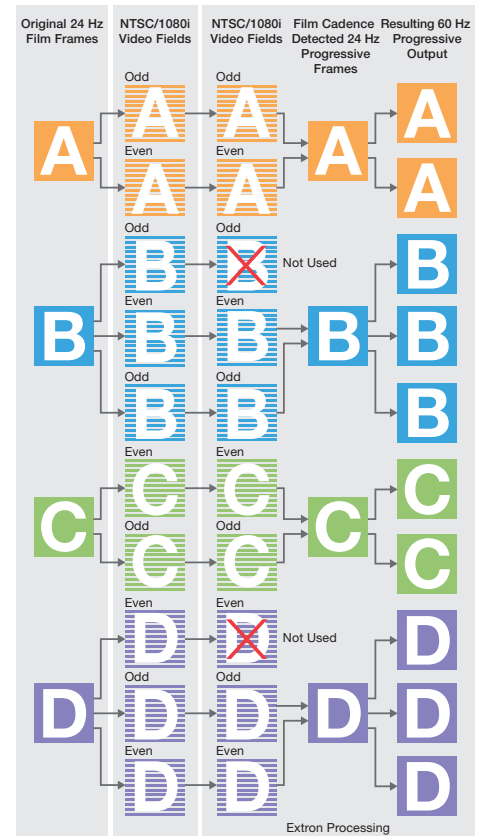

Integration Features

DYNAMIC DIGITAL INPUT DETECTION AND AUTO-IMAGE

The Vector 4K scaling engine goes beyond conventional lookup tables, incorporating dynamic input detection which analyzes incoming digital video signals and accurately measures the signal parameters before processing them for precise conversion and scaling. Coupled with Extron Auto-Image™, Vector 4K can automatically analyze and display both standard and non-standard analog signals, while allowing manual timing adjustments to further optimize performance. Today's evolving computer video standards allow for a wide range of signal resolutions, which may be customized to suit the needs of a particular application or display. These resolutions may be unique to military or medical sources, or the latest consumer laptops or tablets. Such sources can present a challenge for signal processors that rely solely on fixed lookup tables of common resolutions, which are typically incomplete and quickly become obsolete.

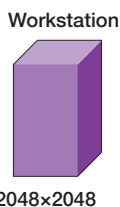
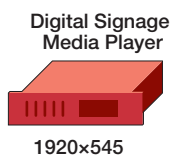

AUTO MEMORY AND USER PRESETS

Auto Input Memory is a powerful convenience feature that automatically saves picture adjustments to memory based on the incoming signal resolution. For analog video, this also includes any signal sampling adjustments made to optimize a non-standard source format. Whenever the signal resolution is detected again by the scaling engine, picture and timing adjustments are then recalled with no user intervention. In addition to Auto Input Memory, Vector 4K provides a separate set of memory presets that can be defined and manually recalled by the user. These presets can be useful when setting up sources connected to a scaler via an external switcher.

Automatic Recall



1080p Auto Memory			
H Pos:	-4	V Pos:	+6
H Size:	1922	V Size:	1079
Contrast:		Brightness:	67
Detail:			

Auto Memory

User Presets

High Contrast			
High Detail			
4x Zoom			
2x Zoom			
H Pos:	+3	V Pos:	
H Size:	3840	V Size:	2160
Contrast:	66	Brightness:	68
Detail:	85		

User-Selectable



DYNAMIC INTERNAL TEST PATTERNS

Extron Vector 4K scalers and signal processors are equipped with a set of dynamic, mathematically generated, vector-based video test patterns. They aid in configuring displays, and provide test signals to facilitate troubleshooting and expedite system recovery. These patterns are precisely generated based on the scaler's output resolution, and are automatically redrawn if the resolution is changed. This ensures that test patterns exactly match the signal resolution, producing sharp, crisp images, which in turn facilitate precise setup and configuration of display devices. An audio pink noise generator is also often included, which can be useful in setting up gain structure and room equalization for the sound system.



Color Bars

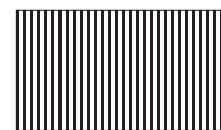

Alt Pixels



Crop



Grayscale

For more information about Vector 4K
visit www.extron.com/vector4k

ASPECT RATIO CONTROL

A frequent challenge in AV presentations is addressing aspect ratio mismatch between a source and a display. This is a common occurrence in applications where participants introduce their own devices into a presentation or collaboration system. Extron Aspect Ratio Control, featured in all products with Vector 4K technology, automatically detects the aspect ratio of an incoming source signal, and provides two user-selectable modes to optimize the content presentation. FOLLOW mode preserves the original aspect ratio of the input signal, while FILL mode provides full-screen output so every pixel of the display contains active content. Additionally, custom aspect ratios can be configured with options for manual or automatic recall of settings.

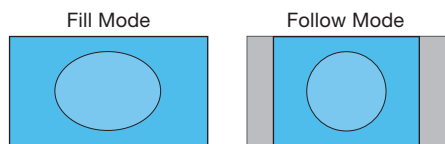

4:3 Content on a 16:9 UHD Display

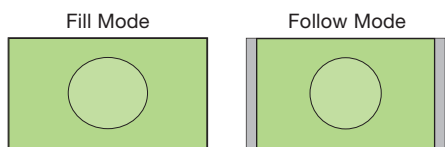

16:10 Content on a 16:9 UHD Display

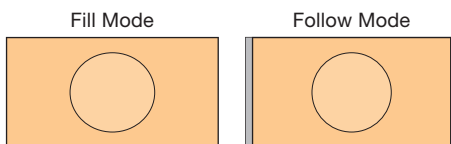

16:9 UHD Content on a 17:9 4K Display



AFL - ACCU-RATE FRAME LOCK

An unavoidable byproduct of scaling with frame rate conversion is periodic dropped or duplicated frames, resulting in a skip or freeze in the scaled video output. It is most noticeable in content with motion elements, particularly camera pans across a scene or an object moving quickly across the camera's view. Extron's multi-patented Accu-RATE Frame Lock - AFL™ technology in the Vector 4K scaling engine completely eliminates the need to add or drop frames by synchronizing the scaler output frame rate to the input signal frame rate. This ensures high-motion content is displayed cleanly and smoothly, identical to the original source. AFL is provided in select Extron video processors, since this feature is traditionally only required in very high-end broadcast or signal conversion applications.

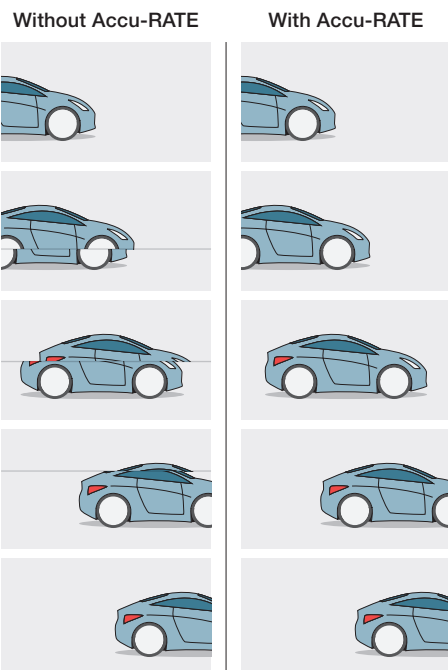

ADVANCED HDCP AND EDID MANAGEMENT

Vector 4K encompasses a range of advanced signal management technologies common across many of Extron's digital video product solutions, simplifying integration of digital video sources and displays, and ensuring optimal system performance and dependability. EDID Minder® manages EDID communication between devices so that preferred video formats are always correctly and reliably output from the source to the receiving device. Custom EDID can also be captured or uploaded to Extron products for special applications. Key Minder® negotiates and maintains continuous HDCP authentication between input and output devices to ensure low-latency switching. Clear visual indicators for HDCP encryption status expedite troubleshooting in the field. Extron SpeedSwitch® Technology incorporates EDID Minder and Key Minder, together with additional Extron-optimized logic to deliver exceptional, virtually instantaneous switching speeds – an essential necessity for professional-quality AV presentations.

**EDID
MINDER**

**KEY
MINDER**

TRUE 4K SPECIFICATIONS

At Extron, we believe in providing you ALL the information you need to select the right product for your system. We have always been the manufacturer you could count on for detailed, clear and honest specifications for our products. Extron is maintaining its leadership position by defining what a complete and detailed product specification for 4K video performance MUST include. We call this the Extron True4K™ Specification. Look for the True4K logo at the top of the specifications for any Extron 4K product, followed by a True4K Specification that always includes resolution, frame rate, color sampling, color bit depth, and data rate.

TRUE 4K SPECIFICATION		
Max 4K Capabilities		
Resolution and Frame Rate	Chroma Sampling	Max Bit Depth per Color
4096 x 2160 at 60 Hz	4:4:4	16 bit
3840 x 2160 at 60 Hz		
Frame Rate	24, 25, 30, 50, or 60 fps	
Chroma Sampling	4:4:4, 4:2:2, or 4:2:0	
Color Bit Depth	8, 10, 12, or 16 bits per color	
Backplane Throughput	50 Gbps per input and output	
NOTE: Use our calculator to determine video parameters supported by this data rate.		

EXTRON VIDEO SIGNAL PROCESSING PATENTS



Method and Apparatus for Interlace-Progressive Video Conversion

Filing Country	Patent Number
USA	7,738,037
USA	6,839,094
Canada	2,429,934
Mexico	243517
China	ZL018203736
EPO-Germany	601452194
EPO-France	1342368
Japan	4947874
EPO-United Kingdom	1342368
Singapore	97313



Method and Apparatus for Resizing a Digital Video Image

Filing Country	Patent Number
USA	6,594,404
EPO-Germany	1003129
EPO-France	1003129
Japan	4643781
EPO-Italy	1003129
EPO-United Kingdom	1003129



Method and Apparatus for Vertically Locking Input and Output Signals

Filing Country	Patent Number
USA	6,441,658
USA	6,316,974
China	814869.4
EPO-Germany	60044510
EPO-Netherlands	1312070
EPO-France	1312070
Japan	4690636
EPO-United Kingdom	990420.2

WORLDWIDE SALES OFFICES

Anaheim • Raleigh • Silicon Valley • Dallas • New York • Washington, DC • Toronto • Mexico City • Paris • London • Frankfurt
 Stockholm • Amersfoort • Moscow • Dubai • Johannesburg • Tel Aviv • Sydney • Melbourne • New Delhi • Bangalore
 Singapore • Seoul • Shanghai • Beijing • Hong Kong • Tokyo

www.extron.com