

WC Pro 150 OCS

Workspace Automation Controller with Occupancy Sensor





User Guide

Workspace Automation Controllers

Safety Instructions

Safety Instructions • English

WARNING: This symbol, , when used on the product, is intended to alert the user of the presence of uninsulated dangerous voltage within the product's enclosure that may present a risk of electric shock.

ATTENTION: This symbol, , when used on the product, is intended to alert the user of important operating and maintenance (servicing) instructions in the literature provided with the equipment.

For information on safety guidelines, regulatory compliances, EMI/EMF compatibility, accessibility, and related topics, see the Extron Safety and Regulatory Compliance Guide, part number 68-290-01, on the Extron website, www.extron.com

تعليمات السلامة • العربية

تحذير: هذا الرمز، , عند استخدامه على المنتج، مخصص لتنبية المستخدم فيما يتعلق بوجود جهد كهربائي غير معزول على الغلاف الخارجي للمنتج وهو ما قد ينطوي على مخاطر حدوث صدمة كهربائية.

انتبه: هذا الرمز، , عند استخدامه على المنتج، مخصص لتنبية المستخدم بتعليمات التشغيل والصيانة الهامة (الخدمة) في المواد التي يتم توفيرها مع المعدات.

للحصول على المزيد من المعلومات حول إرشادات السلامة، والتوافق التنظيمية، والتوافق الكهرومغناطيسي/المجال الكهرومغناطيسي، وإمكانية الوصول، والموضوعات ذات الصلة، يُرجى مراجعة دليل السلامة والتوافق التنظيمي www.extron.com الخاص بباكسترون، الجزء رقم 68-290-01، على موقع إكسترون.

Sicherheitsanweisungen • Deutsch

WARUNG: Dieses Symbol , auf dem Produkt soll den Benutzer darauf aufmerksam machen, dass im Inneren des Gehäuses dieses Produktes gefährliche Spannungen herrschen, die nicht isoliert sind und die einen elektrischen Schlag verursachen können.

VORSICHT: Dieses Symbol , auf dem Produkt soll dem Benutzer in der im Lieferumfang enthaltenen Dokumentation besonders wichtige Hinweise zur Bedienung und Wartung (Instandhaltung) geben.

Weitere Informationen über die Sicherheitsrichtlinien, Produkthandhabung, EMI/EMF-Kompatibilität, Zugänglichkeit und verwandte Themen finden Sie in den Extron-Richtlinien für Sicherheit und Handhabung (Artikelnummer 68-290-01) auf der Extron-Website, www.extron.com

Instrucciones de seguridad • Español

ADVERTENCIA: Este símbolo, , cuando se utiliza en el producto, avisa al usuario de la presencia de voltaje peligroso sin aislar dentro del producto, lo que puede representar un riesgo de descarga eléctrica.

ATENCIÓN: Este símbolo, , cuando se utiliza en el producto, avisa al usuario de la presencia de importantes instrucciones de uso y mantenimiento estas están incluidas en la documentación proporcionada con el equipo.

Para obtener información sobre directrices de seguridad, cumplimiento de normativas, compatibilidad electromagnética, accesibilidad y temas relacionados, consulte la Guía de cumplimiento de normativas y seguridad de Extron, referencia 68-290-01, en el sitio Web de Extron, www.extron.com

Instructions de sécurité • Français

AVERTISSEMENT : Ce pictogramme, , lorsqu'il est utilisé sur le produit, signale à l'utilisateur la présence à l'intérieur du boîtier du produit d'une tension électrique dangereuse susceptible de provoquer un choc électrique.

ATTENTION : Ce pictogramme, , lorsqu'il est utilisé sur le produit, signale à l'utilisateur des instructions d'utilisation ou de maintenance importantes qui se trouvent dans la documentation fournie avec l'équipement.

Pour en savoir plus sur les règles de sécurité, la conformité à la réglementation, la compatibilité EMI/EMF, l'accessibilité, et autres sujets connexes, lisez les informations de sécurité et de conformité Extron, réf. 68-290-01, sur le site Extron, www.extron.com

Istruzioni di sicurezza • Italiano

AVVERTENZA: Il simbolo, , se usato sul prodotto, serve ad avvertire l'utente della presenza di tensione non isolata pericolosa all'interno del contenitore del prodotto che può costituire un rischio di scosse elettriche.

ATTENZIONE: Il simbolo, , se usato sul prodotto, serve ad avvertire l'utente della presenza di importanti istruzioni di funzionamento e manutenzione nella documentazione fornita con l'apparecchio.

Per informazioni su parametri di sicurezza, conformità alle normative, compatibilità EMI/EMF, accessibilità e argomenti simili, fare riferimento alla Guida alla conformità normativa e di sicurezza di Extron, cod. articolo 68-290-01, sul sito web di Extron, www.extron.com

Instrukcje bezpieczeństwa • Polska

OSTRZEŻENIE: Ten symbol, , gdy używany na produkt, ma na celu poinformować użytkownika o obecności izolowanego i niebezpiecznego napięcia wewnątrz obudowy produktu, który może stanowić zagrożenie porażenia prądem elektrycznym.

UWAGI: Ten symbol, , gdy używany na produkt, jest przeznaczony do ostrzegania użytkownika ważne operacyjne oraz instrukcje konserwacji (obsługi) w literaturze, wyposażone w sprzęt.

Informacji na temat wytycznych w sprawie bezpieczeństwa, regulacji wzajemnej zgodności, zgodność EMI/EMF, dostępności i Tematy pokrewne, zobacz Extron bezpieczeństwa i regulacyjnego zgodności przewodnik, część numer 68-290-01, na stronie internetowej Extron, www.extron.com

Инструкция по технике безопасности • Русский

ПРЕДУПРЕЖДЕНИЕ: Данный символ, , если указан на продукте, предупреждает пользователя о наличии неизолированного опасного напряжения внутри корпуса продукта, которое может привести к поражению электрическим током.

ВНИМАНИЕ: Данный символ, , если указан на продукте, предупреждает пользователя о наличии важных инструкций по эксплуатации и обслуживанию в руководстве, прилагаемом к данному оборудованию.

Для получения информации о правилах техники безопасности, соблюдении нормативных требований, электромагнитной совместимости (ЭМП/ЭДС), возможности доступа и других вопросах см. руководство по безопасности и соблюдению нормативных требований Extron на сайте Extron: www.extron.com номер по каталогу - 68-290-01.

安全说明 • 简体中文

警告 ⚠️ 产品上的这个标志意在警告用户, 该产品机壳内有暴露的危险电压, 有触电危险。

注意 ⚠️ 产品上的这个标志意在提示用户, 设备随附的用户手册中有重要的操作和维护(维修)说明。

关于我们产品的安全指南、遵循的规范、EMI/EMF 的兼容性、无障碍使用的特性等相关内容, 敬请访问 Extron 网站, www.extron.com, 参见 Extron 安全规范指南, 产品编号 68-290-01。

安全記事 • 繁體中文

警告 ⚠️ 若產品上使用此符號, 是為了提醒使用者, 產品機殼內存在未隔離的危險電壓, 可能會導致觸電之風險。

注意 ⚠️ 若產品上使用此符號, 是為了提醒使用者, 設備隨附的用戶手冊中有重要的操作和維護(維修)說明。

有關安全性指導方針、法規遵守、EMI/EMF 相容性、存取範圍和相關主題的詳細資訊, 請瀏覽 Extron 網站: www.extron.com, 然後參閱《Extron 安全性與法規遵守手冊》, 準則編號 68-290-01。

安全上のご注意 • 日本語

警告: この記号 ⚠️ が製品上に表示されている場合は、筐体内に絶縁されていない高電圧が流れ、感電の危険があることを示しています。

注意: この記号 ⚠️ が製品上に表示されている場合は、本機の取扱説明書に記載されている重要な操作と保守(整備)の指示についてユーザーの注意を喚起するものです。

安全上のご注意、法規遵守、EMI/EMF適合性、その他の関連項目については、エクストロンのウェブサイト www.extron.com より「Extron Safety and Regulatory Compliance Guide」(P/N 68-290-01) をご覧ください。

안전 지침 • 한국어

경고: 이 기호 ⚠️ 가 제품에 사용될 경우, 제품의 인클로저 내에 있는 접지되지 않은 위험한 전류로 인해 사용자가 감전될 위험이 있음을 경고합니다.

주의: 이 기호 ⚠️ 가 제품에 사용될 경우, 장비와 함께 제공된 책자에 나와 있는 주요 운영 및 유지보수(정비) 지침을 경고합니다.

안전 가이드라인, 규제 준수, EMI/EMF 호환성, 접근성, 그리고 관련 항목에 대한 자세한 내용은 Extron 웹 사이트(www.extron.com)의 Extron 안전 및 규제 준수 안내서, 68-290-01 조항을 참조하십시오.

Copyright

© 2025 Extron. All rights reserved. www.extron.com

Trademarks

All trademarks mentioned in this guide are the properties of their respective owners.

The following registered trademarks (®), registered service marks (SM), and trademarks (TM) are the property of RGB Systems, Inc. or Extron (see the current list of trademarks on the [Terms of Use](http://www.extron.com) page at www.extron.com):

Registered Trademarks (®)
Extron®, Cable Cubby®, ControlScript®, CrossPoint®, DTP®, eBUS®, EDID Manager®, EDID Minder®, eLink®, Everlast®, Flat Field®, FlexOS®, Glitch Free®, GlobalViewer®, Global Configurator®, Global Scripter®, Hideaway®, HyperLane®, IP Intercom®, IP Link®, Key Minder®, LinkLicense®, LockIt®, MediaLink®, MediaPort®, NAV®, NetPA®, PlenumVault®, PoleVault®, PowerCage®, PURE3®, Quantum®, ShareLink®, Show Me®, StudioStation®, SoundField®, SpeedMount®, SpeedSwitch®, System INTEGRATOR®, TeamWork®, TouchLink®, V-Lock®, VN-Matrix®, VoiceLift®, WallVault®, WindoWall®, XPA®, XTP®, XTP Systems®, ZipClip®
Registered Service Mark (SM) : S3 Service Support Solutions
Trademarks (TM)
AAP™, AFL™ - Accu-RATE Frame Lock, ADSP™ - Advanced Digital Sync Processing, AVEdge™, CableCover™, CDRS™ - Class D Ripple Suppression, Codec Connect™, ConferenceShare™, DDSP™ - Digital Display Sync Processing, DMI™ - Dynamic Motion Interpolation, Driver Configurator™, DSP Configurator™, DSP Configurator Pro™, DSVP™ - Digital Sync Validation Processing, EQIP™, FastBite™, Flex55™, FOX™, FOXBOX™, InstaWake™, IP Intercom HelpDesk™, MAAP™, MicroDigital™, Opti-Torque™, PendantConnect™, ProDSP™, QS-FPC™ - QuickSwitch Front Panel Controller, Room Agent™, Scope-Trigger™, SIS™ - Simple Instruction Set, Skew-Free™, SpeedNav™, Triple-Action Switching™, True4K™, True8K™, Vector™ 4K, WebShare™, XTRA™, ZipCaddy™

FCC Class A Notice

This equipment has been tested and found to comply with the limits for a Class A digital device, pursuant to part 15 of the FCC rules. The Class A limits provide reasonable protection against harmful interference when the equipment is operated in a commercial environment. This equipment generates, uses, and can radiate radio frequency energy and, if not installed and used in accordance with the instruction manual, may cause harmful interference to radio communications. Operation of this equipment in a residential area is likely to cause interference. This interference must be corrected at the expense of the user.

NOTE: For more information on safety guidelines, regulatory compliances, EMI/EMF compatibility, accessibility, and related topics, see the [Extron Safety and Regulatory Compliance Guide](#) on the Extron website.

Conventions Used in this Guide

Notifications

The following notifications are used in this guide:

 **WARNING:** Potential risk of severe injury or death.
AVERTISSEMENT : Risque potentiel de blessure grave ou de mort.

ATTENTION:

- Risk of property damage.
- Risque de dommages matériels.

NOTE: A note draws attention to important information.

TIP: A tip provides a suggestion to make working with the application easier.

Software Commands

Commands are written in the fonts shown here:

```
^AR Merge Scene,,0p1 scene 1,1 ^B 51 ^W^C.0  
[01] R 0004 00300 00400 00800 00600 [02] 35 [17] [03]  
Esc [X1] * [X17] * [X20] * [X23] * [X21] CE ←
```

NOTE: For commands and examples of computer or device responses used in this guide, the character “0” is the number zero and “O” is the capital letter “o.”

Computer responses and directory paths that do not have variables are written in the font shown here:

```
Reply from 208.132.180.48: bytes=32 times=2ms TTL=32  
C:\Program Files\Extron
```

Variables are written in italics as shown here:

```
ping xxx.xxx.xxx.xxx -t  
SOH R Data STX Command ETB ETX
```

Selectable items, such as menu names, menu options, buttons, tabs, and field names are written in the font shown here:

```
From the File menu, select New.  
Click the OK button.
```

Specifications Availability

Product specifications are available on the Extron website, www.extron.com.

Extron Glossary of Terms

A glossary of terms is available at <https://www.extron.com/technology/glossary.aspx>.

Contents

Introduction.....	1
Before You Begin.....	1
What This Guide Covers	1
Conventions Used in This Guide.....	1
About the WC Pro 150 OCS.....	1
Features	2
Application Diagrams	3
Pre-configured WC Pro 150 OCS	4
Pre-Configured features.....	4
Room Occupancy Status on the Digital Output Port 2.....	4
Configuration of the WC Pro 150 OCS with the Internal Web Page.....	4
Advanced Configuration of the WC Pro 150 OCS with GCP.....	5
What the Software Does	5
About ControlScript Programming	5
PC System Requirements	6
<hr/>	
Installation and Operation	7
Installation Step 1: Get Ready.....	7
Installation Step 2: Prepare the Installation Site.....	8
Accessibility and Americans with Disabilities Act (ADA) Compliance	8
Installation Step 3: Cable All Devices.....	8
Port Expansion Interface Connections and Cabling.....	8
Panel Features.....	15
Installation Step 4: Set up Network Communication	17
Installation Step 5: Configure the WC Pro 150 OCS.....	17
Installation Step 6: Test and Troubleshoot.....	18
Installation Step 7: Mounting	18
Resetting the Unit.....	20
Motion Sensor Coverage.....	22
<hr/>	
Internal Web Page Configuration.....	25
Accessing the Internal Web Page	25
Configuration with the Web Pages	26
Device Detail Panel.....	27
Unit Status Panel	27
Backup, Restore, Reboot, and Reset Links	27
Network Panel.....	28
Date and Time Panel.....	29
Roles and Permissions Panel	30
Firmware Panel.....	31
Display Control Page	32

Sensor Page	36
About the WC Pro 150 OCS	38

Advanced Software Configuration..... 39

Configuration and Control: an Overview	39
Basic Setup Steps: a Guide to this Section and Other Resources.....	40
Downloading the Software and Getting Started	41
Locating Software, Firmware, and Driver Files on the Extron Website.....	41
Obtaining Control Drivers.....	42
Things to Do After Installing GC and Before Starting a Project.....	42
Using GC: Helpful Tips	42
Troubleshooting.....	43
Connections and Configuration.....	43

Reference Information 44

UL Guidelines	44
Consignes UL.....	44
Best Practices for Cleaning Your Extron Products	45
Network Port Requirements and Licensed Third-Party Software	45
File Types: a Key to Extron-Specific File Names.....	45
SNMP	46
Activity Statistics.....	46

Firmware Updates 47

Determining the Firmware Version	47
Using Toolbelt.....	47
Using a Browser.....	47
Updating the Firmware	47
Locating and Downloading the Firmware.....	48
Installing Firmware	48

Introduction

This section covers the following information you should know about this guide and the products before installation:

- [Before You Begin](#)
- [About the WC Pro 150 OCS](#)
- [Application Diagrams](#)
- [Pre-configured WC Pro 150 OCS](#)
- [Advanced Configuration of the WC Pro 150 OCS with GCP](#)
- [PC System Requirements](#)

Before You Begin

What This Guide Covers

This user guide provides instructions for an experienced installer to install an Extron WC Pro 150 OCS Workspace Controller. This guide includes detailed information and best practices recommendations about cabling the controller, a brief overview of the configuration process, and reference information.

Configure the controller using Extron Global Configurator software running in Global Configurator Professional (GC Professional) or Global Configurator Plus (GC Plus) mode or program it using ControlScript programming. This guide does not contain instructions on detailed software-related setup steps or details of configuration within the software (see the *Global Configurator Help File*, *ControlScript Deployment Utility Help File*, and help files for related programs). The software help files describe how to use each program to download drivers, add AV devices to a configuration, and configure basic functions.

Conventions Used in This Guide

Throughout this guide the WC Pro 150 OCS is also referred to as the “WC”, “WC Pro”, “sensor”, or “controller”.

Global Configurator software is referred to as “GC,” which can be run in Global Configurator Professional mode (“GC Professional”) or Global Configurator Plus mode (“GC Plus”).

“ControlScript programming” encompasses ControlScript Deployment Utility (CSDU) and ControlScript Extension.

About the WC Pro 150 OCS

The WC Pro 150 OCS Workspace Automation Controller is a small and medium space, PoE powered occupancy control processor with an integrated occupancy sensor used to detect motion using Passive Infrared (PIR) and an acoustic sensor, when people walk into a small to medium conference room. Unique status LED indicators for each sensor are used for ease of installation as well as intuitive setup.

There are four ways the WC Pro 150 OCS can be configured:

- First, out of box the workspace controller is preconfigured for CEC control of display (see the PDF of the [CEC Compatibility Chart](#)) with the digital output 2 following the occupancy state.
- Second, simple web configuration can be done via the internal web page for basic power on and off automation of display and projector devices (see [Internal Web Page Configuration](#) on page 25).
- Third, advanced configuration can be done using Global Configurator Professional (GC Professional) or Global Configurator Plus (GC Plus). For configuration with Global Configurator Professional (GC Professional) or Global Configurator Plus (GC Plus), the LinkLicense for WC Pro Control Processor is required.
- Fourth, program it using ControlScript programming. The LinkLicense for WC Pro Control Processor is required.

Global Configurator, CSDU, and other useful software applications are available at www.extron.com.

Once it is set up to work as desired (set up IP addresses and functions, assigned drivers to ports, configured digital input and user interface), the information is saved to a project configuration file that is built and uploaded into the WC Pro 150 OCS.

The WC Pro 150 OCS integrates seamlessly with Extron GlobalViewer Enterprise (GVE) software and the GlobalViewer web-based AV resource management tool for remote control applications when the unit is configured with GCP configurator.

Features

- **Out-of-the-box functionality that supports display control via CEC from an HDMI port and the digital output #2, which follows occupancy status** — This delivers convenient, automatic display power control using room occupancy detection.
- **Built-in webpage allows for simple configuration of the sensors and provides a choice of one Ethernet, RS-232, or IR control method of the display power.**
- **Dual occupancy sensing technology** — Passive Infrared and acoustic sensors provide a wide coverage area with excellent detection capabilities.
- **LinkLicense for WC Pro Control Processor provides several enhancements** —
 - Configuration using Extron Global Configurator Plus or Professional control system software.
 - Programming using ControlScript Deployment Utility.
 - Support of TouchLink Pro touchpanels, Network Button Panels, and Secure Platform Devices.
 - Manage, monitor, and control AV devices using a standard Ethernet network.
 - Library of Pro Series device drivers and modules for use with Global Configurator and ControlScript respectively.
 - LinkLicense for User Interfaces is an easy way for people to use their mobile devices or computers as primary control interfaces.
- **One bidirectional RS-232 serial port** — Captive screw serial port that allows for control of one RS-232 device.
- **Two digital I/O ports** — Allow for connections with a variety of devices including sensors, switches, and relays.
- **One IR port for one-way control of AV devices.**
- **PoE powered** — Product is powered directly by a PoE switch or injector, eliminating the need for a local power supply.
- **Includes mounting bracket for installation flexibility** — Allows mounting to a wall or surface above or below a display, using the long or short side of the L-bracket. This provides depth adjustment for the mounting.
- **Allows mounting on accessories with a ¼"-20 universal thread mount.**
- **The Port Expansion Interface on a 3' pigtail provides discreet port access from behind the display** — The interface contains an Ethernet port, bidirectional RS-232 port, IR port, and two digital I/O ports.

Network and configuration features

- **Global compatibility** — The WC uses industry standard Ethernet communication protocols, including DHCP, DNS, HTTP, HTTPS, ICMP, NTP, SFTP, SMTP, SNMP, SSH, TCP/IP, and UDP/IP.
- **Network connection** — The WC Pro 150 OCS supports 10/100Base-T Ethernet communication.
- **Multi-level password protection** — Allows security to be set based on user roles.
- **System asset management** — The configured system and controller allow you to control, monitor, and schedule various functions of devices in the system.
- **E-mail notification** — The WC can be set up to send e-mail notifications, such as a notice that a projector has been disconnected or the projector lamp has been used for a designated number of hours.
- **Support for Extron ControlScript Pro xi.**

- **Remote equipment management** — The IP Link Pro connection via the LAN port on the WC Pro allows you to remotely manage, monitor, and control several Ethernet-enabled products such as projectors, cameras, video conferencing equipment, switchers, and other AV equipment. The WC provides support for the following:
 - TCP, UDP, and HTTP connections
 - Password protection using secure communication
 - Ethernet devices on the configuration mode (GC Professional or GC Plus)
 - Connection via IP address or host name

Application Diagrams

Figure 1 and figure 2 show examples of the types of devices that can be connected to ports on the WC Pro 150 OCS controller.

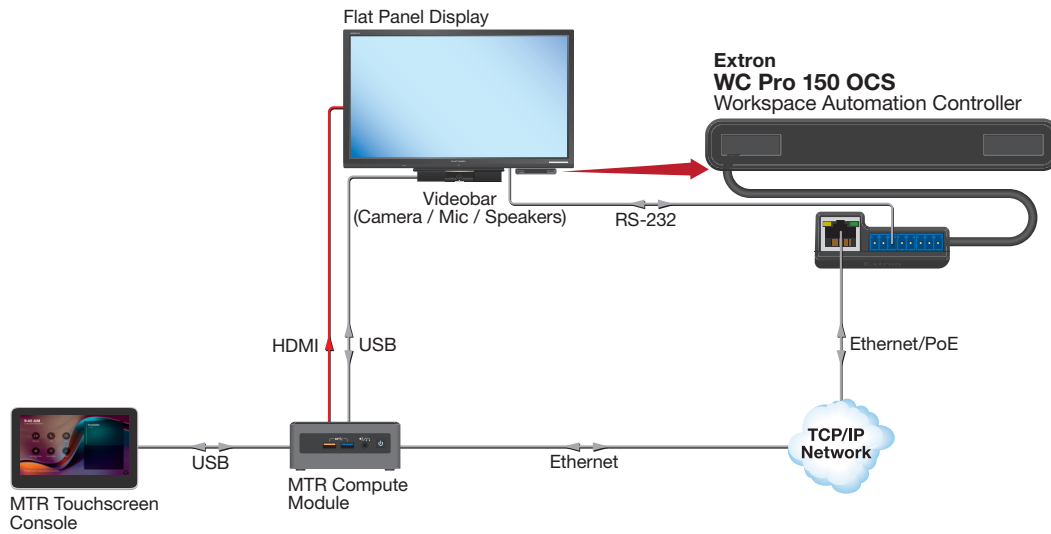

Figure 1. WC Pro 150 OCS Application Diagram

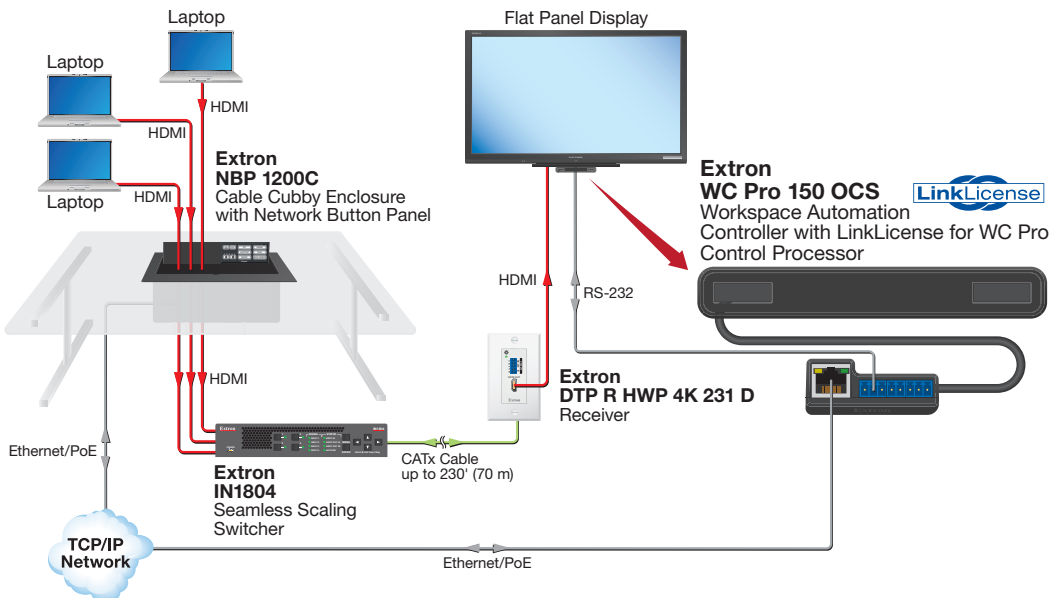

Figure 2. WC Pro 150 OCS Application Diagram

Pre-configured WC Pro 150 OCS

The WC Pro 150 OCS is pre-configured and fully functional “out of the box” using CEC commands for display control based on occupancy sensor detection. This factory configuration can be modified using the Internal Web Page. If the WC Pro 150 OCS is reset, the device reverts back to the factory out-of-box default web configuration with CEC display control.

The WC Pro 150 OCS internal web pages can be accessed via a LAN connection to configure certain settings. Use a web browser to view the pages on a PC or any other mobile device connected to the device LAN port or the same network (see [Internal Web Page Configuration](#) starting on page 25).

Pre-Configured features

- **Display On** — Display is powered on with a CEC command when occupancy is detected.
- **Display Off** — Display is powered off with a CEC command when no occupancy is detected and the timer has expired.

Room Occupancy Status on the Digital Output Port 2

Out of the box, Digital Output 2 is pull-up enabled, which follows the occupancy status:

- When status is unoccupied the digital output is low (0 V).
- When status is occupied the digital output is high (5 V).

If the unit is web configured, this fixed functionality still remains. The user cannot change anything about this functionality. It is fixed.

If the unit is GCP configured, this fixed functionality of digital I/O is lost and GCP takes over the functionality of these ports.

Configuration of the WC Pro 150 OCS with the Internal Web Page

NOTE: A Universal Access Key is required to configure the WC Pro 150 OCS using the internal web page. The unit cannot be configured with the Internal Web Page if it is configured with Extron Global Configurator software or ControlScript programming. To obtain a Universal Access Key, go to www.extron.com/myaccount/uak. If an Insider account holder obtains a UAK file, it expires in 90 days. If a guest account holder obtains a UAK file, it expires in 7 days. After expiration, the user needs to obtain a new UAK file.

The WC Pro 150 OCS workspace controller features internal web pages. Configure and monitor certain settings of the WC Pro device via a LAN connection. Use a web browser to view the pages on a PC or any other mobile device connected to the device LAN port or the same network. The internal web page provides configuration panels for the date and time, network connections, passwords, and firmware update. It also provides pages for sensor and display control, editable drop-down panels and buttons to backup, restore, reboot and reset the unit (see [Internal Web Page Configuration](#) starting on page 25).

Extron loaded drivers are available on the Display Control Connection tab. If a driver is needed that is not pre-loaded, the user can search and download a new or updated driver, then import it via the internal web pages. For Web-Based Automation Drivers go to www.extron.com/download/automation-drivers.

Advanced Configuration of the WC Pro 150 OCS with GCP

NOTE: The LinkLicense for WC Pro Control Processor is optional for the WC Pro 150 OCS. This LinkLicense gives access to GCP software. It is not needed for web based configuration via the internal web pages.

The most basic steps are outlined below in the recommended order.

NOTE: See the *Toolbelt Help File*, *Global Configurator Help File*, and *ControlScript Help File* as needed for step-by-step instructions and detailed information. The help file for GC includes an introduction to the software, and how to start a project and configuration.

1. Using Toolbelt, adjust sensor sensitivity, inactivity timer, enable and disable sensors, and configure network settings.
2. Using GC, create a new GC Plus or GC Professional project and configure the controller. The configuration tells the controller how its ports function, how to control the display, what to monitor, when to do things, and whom to notify, how, and under what circumstances.
 - a. Configure ports on the controller.
 - Select device drivers and link them to each assigned serial, IR, or Ethernet port.
 - Configure settings (CEC, serial protocol, digital input and output, and Ethernet control settings) as needed.
 - b. Add user interface devices such as Surge Protection Devices (SPD), Network Button Panels (NBP), or TouchLink Pro Touchpanels (TLP) devices to the controller as needed.
 - c. Set up monitors, schedules, macros, and local variables.
3. Save the project.
4. Build and upload the system configuration to the controller.

What the Software Does

Global Configurator Professional or Plus is the software tool for configuration of a controller.

- Loads device drivers for controlling and monitoring the status of devices within the AV system.
- Creates the configuration containing all the settings for the controller and the products it interacts within the AV system.
- Generates a user interface called GlobalViewer that is uploaded to the WC Pro 150 OCS (a GlobalViewer host device) along with the completed configuration and can be accessed as a web page. Using GlobalViewer, users can monitor the WC Pro 150 OCS.

When the Extron LinkLicense for User Interface is enabled on the controller, Extron Control for web, iOS, or Android can be used with the WC Pro 150 OCS to permit remote control of the unit and, by extension, the Extron and third-party equipment (such as switchers, projectors, displays, computer monitors, and DVD players) that the WC Pro 150 OCS is configured to control.

NOTE: To use Global Configurator (available to run in GC Plus mode) software, you must have an Extron Insider account and contact an Extron support representative. Extron provides training to our customers on how to use the software. Access to Global Configurator Professional is available to users who successfully complete Extron Control Professional Certification.

About ControlScript Programming

For those who prefer to program control systems rather than configure them, Extron offers ControlScript programming as an alternative to Global Configurator. It encompasses ControlScript Deployment Utility (CSDU), ControlScript Extension for VS Code, and ControlScript programming is an integrated programming development environment for Extron control processors, user interfaces, network button panels, and expansion interfaces.

The programming environment includes the ControlScript API, as well as all of the tools for developing control system programs, such as file management, code editing, debugging and diagnostic tools. More information is available at <https://www.extron.com/featured/Control-System-Programming/programming>.

PC System Requirements

To find the minimum hardware and software requirements for the PC used to configure the WC Pro 150 OCS:

- Visit the Download page (www.extron.com/download/index.aspx) on the Extron website and navigate to the web page for the specific software package (such as Global Configurator or ControlScript).
- Minimum system requirements are listed in the description section. In some cases, minimum device firmware version requirements are also listed there.

If system requirements are not listed on the software package web page, contact an Extron support representative.

Installation and Operation

This section covers the following:

- [Installation Step 1: Get Ready](#)
- [Installation Step 2: Prepare the Installation Site](#)
- [Installation Step 3: Cable All Devices](#)
- [Installation Step 4: Set up Network Communication](#)
- [Installation Step 5: Configure the WC Pro 150 OCS](#)
- [Installation Step 6: Test and Troubleshoot](#)
- [Installation Step 7: Mounting](#)
- [Resetting the Unit](#)

Follow the installation steps in this guide or in the setup guide and use it for reference throughout the installation and configuration process.

Installation Step 1: Get Ready

Use the following checklist to prepare for the installation.

1. Download and install the latest version of the following:

NOTE: If using the WC Pro 150 OCS with the out of the box configuration or the internal web pages for configuration, skip to [Installation Step 2: Prepare the Installation Site](#) on page 8.

- **Global Configurator Professional or Global Configurator Plus software** — For setting up and configuring the controller. GC includes a link to the **Toolbelt** software and a way to upgrade the firmware of the controller. An Extron Insider account is necessary to use GC software (see [Locating Software, Firmware, and Driver Files on the Extron Website](#) on page 41).
- **ControlScript Deployment Utility (ControlScript Pro xi software)** — For programming the control processor (as an alternative to GC).
- **Toolbelt software** — For setting up the controller.
- **IP Link Pro device drivers** — For use with GC (Professional or Plus), to make control of other devices possible. Go to: www.extron.com/download/control-system-drivers.
- **LinkLicense files** — For use with GC (Professional or Plus) for configuration.
- **Web-based automation drivers** — Go to: www.extron.com/download/automation-drivers.

All are available from www.extron.com.

2. Obtain network information for the unit from the network administrator. The following details for each IP Link Pro device such as the WC Pro 150 OCS are needed:
 - DHCP setting (on or off)
 - Subnet mask
 - User name
 - WC Pro 150 OCS IP address
 - Gateway IP address
 - Passwords
3. Write down the MAC address of the WC Pro 150 OCS to be used.
4. Obtain model names and setup information for devices the WC Pro 150 OCS will control.

Installation Step 2: Prepare the Installation Site

Select and prepare the site before cabling the controller. This may include cutting a hole in the installation surface or installing a cabling raceway, running the cables to that site, and pulling cables through it .

ATTENTION:

- Installation and service must be performed by authorized personnel only.
- L'installation et l'entretien doivent être effectués uniquement par un technicien qualifié.
- Follow all national and local building and electrical codes that apply to the installation site.
- Respectez tous les codes électriques et du bâtiment, nationaux et locaux, qui s'appliquent au site de l'installation.

Accessibility and Americans with Disabilities Act (ADA) Compliance

When planning where to install the WC Pro 150 OCS, consider factors affecting accessibility of the controller such as height from the floor, distance from obstructions, and how far a user must reach to insert a connector. For guidelines, see sections 307 (“Protruding Objects”) and 308 (“Reach Ranges”) of the *2010 ADA Standards for Accessible Design* available at <http://www.ada.gov/regs2010/2010ADAStandards/2010ADAStandards.pdf>.

Installation Step 3: Cable All Devices

1. Cable devices to the controller. Use the wiring diagrams in **Port Expansion Interface Connections and Cabling**.
2. Connect power cords and power on all the devices.

Port Expansion Interface Connections and Cabling

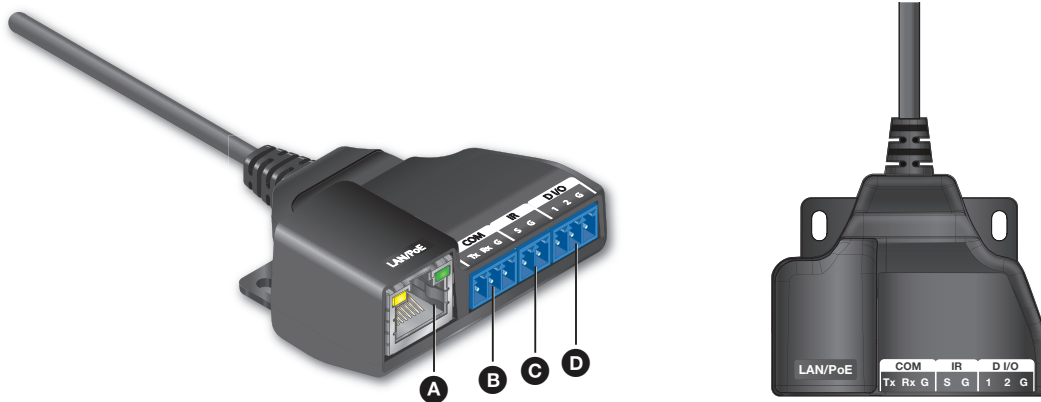

- A** LAN (Ethernet) and PoE port and LEDs
- B** RS-232 COM control port
- C** IR control port
- D** Digital Input and Output

Figure 3. WC Pro 150 OCS Expansion Interface Ports

Control and power — LAN (Ethernet) and PoE

- A** **LAN (Ethernet) and PoE port and LEDs** — Connect the WC Pro 150 OCS to an Ethernet network. Plug a cable from the LAN RJ-45 socket to a network switch, hub, router, or PC connected to a LAN or the Internet. Configure and control the WC Pro 150 OCS and the devices connected via Extron Control app (see [Network Port Requirements and Licensed Third-Party Software](#) on page 45).

The WC Pro controller accepts Power over Ethernet (PoE) through the LAN port.

ATTENTION:

- Power over Ethernet (PoE) is intended for indoor use only. It is to be connected only to networks or circuits that are not routed to the outside plant or building.
- L'alimentation via Ethernet (PoE) est destinée à une utilisation en intérieur uniquement. Elle doit être connectée seulement à des réseaux ou des circuits qui ne sont pas routés au réseau ou au bâtiment extérieur.
- The WC Pro 150 OCS is intended for connection to a Power over Ethernet circuit for intra-building use only and are considered to be part of a Network Environment 0 per IEC TR62101.
- Le WC Pro 150 OCS est conçu pour une connexion à un circuit PoE pour une utilisation intérieure seulement et est considéré comme faisant partie d'un environnement réseau 0 par IEC TR62101.

NOTE: A quick way to get the unit on your network is to press and release the reset button 5 times to toggle (enable) DHCP on. From the factory it is disabled, with a static IP address. Once DHCP is enabled and the device is connected to the network, access the internal web page via hostname. domain.com, for example: WC-PRO-150-OCS-XX-XX-XX.extron.com (XX-XX-XX are the last three octets of the MAC address, located on the MAC address label on the device).

Cabling:

- For 10Base-T (10 Mbps) networks, use a CAT 3 or better cable.
- For 100Base-T (max. 155 Mbps, all models) networks, use a CAT 5 cable.

LEDs:

- **Activity LED** — This yellow LED blinks to indicate network activity.
- **Link LED** — This green LED lights to indicate a good network connection.

NOTE: DHCP is off by default.

MAC address — This is the unique user hardware ID number (MAC address) of the unit (for example, 00-05-A6-05-1C-A0). This address may be needed during configuration. The label is on the rear panel.

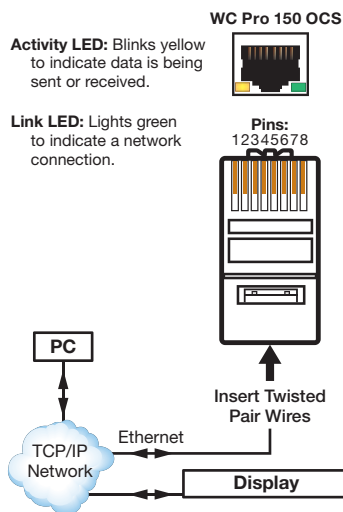
**ATTENTION:**

- Power over Ethernet (PoE) is intended for indoor use only. It is to be connected only to networks or circuits that are not routed to the outside plant or building.
- L'alimentation via Ethernet (PoE) est destinée à une utilisation en intérieur uniquement. Elle doit être connectée seulement à des réseaux ou des circuits qui ne sont pas routés au réseau ou au bâtiment extérieur.

Straight-through Cable (for connection to a switch, hub, or router)			
Pin	End 1 Wire Color	Pin	End 2 Wire Color
1	white-orange	1	white-orange
2	orange	2	orange
3	white-green	3	white-green
4	blue	4	blue
5	white-blue	5	white-blue
6	green	6	green
7	white-brown	7	white-brown
8	brown	8	brown

TIA/EIA-T568B

T568B

NOTE: The factory configured passwords for all accounts on this device have been set to the device serial number. In the event of a complete system reset, the passwords convert to the default, which is extron.

LAN/PoE (Ethernet and Power Over Ethernet)

Connect to an Ethernet network with a straight through cable. This port must be configured.

Default protocol:

- Device IP address: 192.168.254.250
- Gateway IP address: 0.0.0.0
- Subnet mask: 255.255.255.0
- DNS address: 127.0.0.1
- DHCP: off
- Link speed and duplex level: autodetected
- Data rates: 10/100 Base-T

Power over Ethernet (PoE):

- The WC only uses PoE.
- 48V/56Vdc

Default login credentials:

- Username: admin
- Password: extron

Use this port to upload configuration files and firmware.

Figure 4. LAN Connector and LEDs

Control — COM RS-232

- B RS-232 COM control port** (see [figure 3](#) on page 8) — Use for serial control of a display or other device and to receive status messages from the connected devices. This port can send commands from a driver file. This port supports only RS-232 communication.

WC Pro 150 OCS Serial protocol:

- 300 to 115200 baud (9600 baud = **default**)
- 8 (**default**) or 7 data bits
- 1 (**default**) or 2 stop bits
- No parity (**default**), even, or odd parity
- Flow control support (**default** = none): software-only (XON, XOFF)

Use the diagram in figure 5 as a wiring guide to cable the controller to other devices.

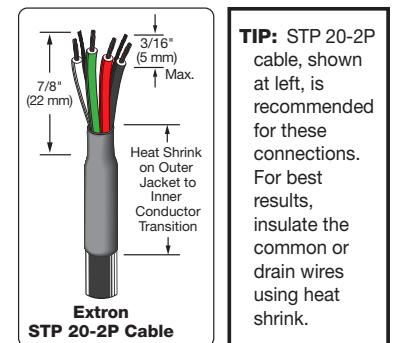

Figure 5. Wiring the RS-232

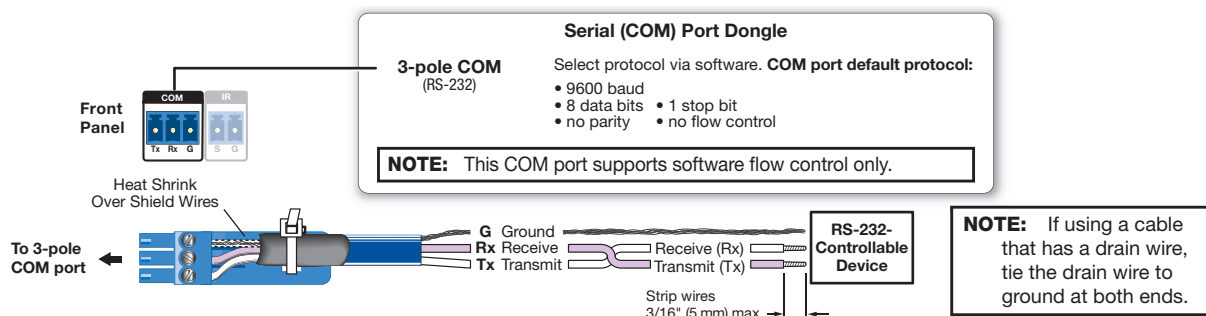

Figure 6. Wiring COM Ports for Serial Control

For bidirectional serial communication, the transmit, ground, and receive pins must be wired at both the controller and the other device. Each projector or other device may require different wiring. For details, see the manual for that device or read the Extron device driver communication sheet, included with the drivers.

NOTE: Maximum distances between the WC Pro 150 OCS and the device being controlled may vary up to 200 feet (61 m). Factors such as cable gauge, baud rates, environment, and output levels (from the WC Pro 150 OCS and the device being controlled) all affect transmission distance.

Control — IR and Digital I/O

- C IR control port** (see [figure 3](#)) — An WC Pro 150 OCS controller can use infrared signals to control up to two devices via this port.

Connect the port directly to the wired IR port of another device, or insert the wires from up to two IR Emitters into this IR port and place the heads of the emitters over or next to the IR signal pickup windows of the devices. For wiring, see the following diagrams or the *IR Emitter Installation Guide* (available at www.extron.com).

NOTE: Each emitter must be within 100 feet (30 m) of the controller for best results.

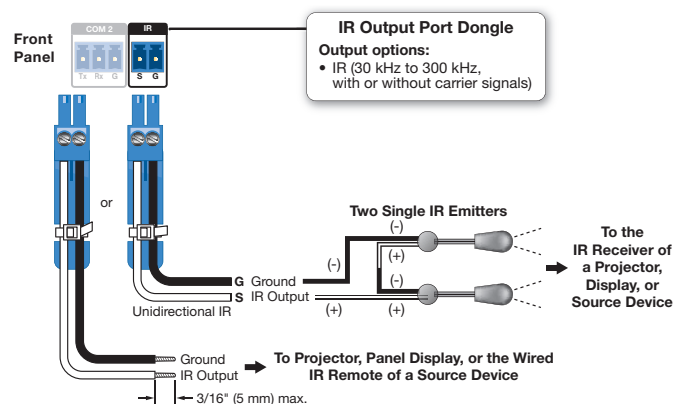
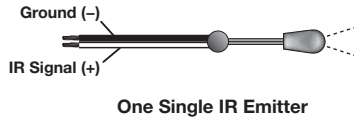
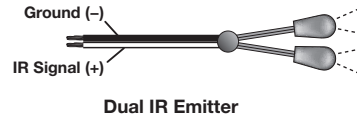

Figure 7. Wiring the IR Port

Installing One Single Emitter



Installing One Dual Emitter



Installing Two Single Emitters

When installing only single emitters, tie them **in series** as shown below.

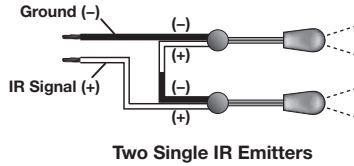

- D **Digital input/output port** (see [figure 3](#) on page 8) — Connect a switch, sensor, LED, relay contact, or similar item to this port (see figure 8).

If the WC Pro 150 OCS is operating with the out of the box pre-configured functionality, go to [Room Occupancy Status on the Digital Output Port 2](#) on page 4 for information on how the digital output port 2 operates.

Digital input — To allow the controller to monitor external devices, connect a switch, motion sensor, moisture sensor, tally feedback output, button pad, or a similar item to a digital input port and configure the port. The port is set to measure two states: high and low. The port accepts 0 to 24 VDC input.

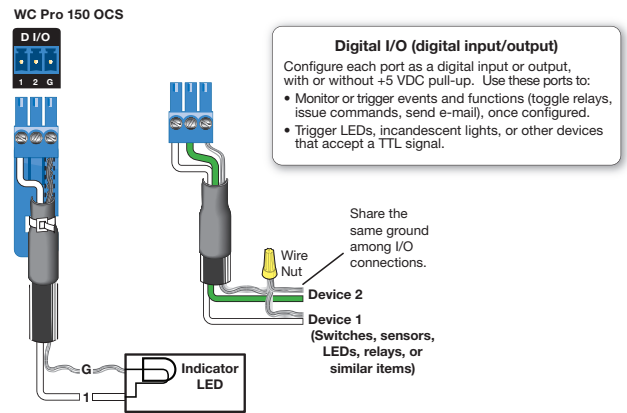

Figure 8. Digital Input Port Wiring

Threshold voltages are **not** adjustable. The thresholds are as follows:

- < **2.0** VDC — port on, logic low
 - > **2.8** VDC — port off, logic high
- There is also an internal, +5 VDC, selectable, pull-up resistor for this circuit, which can be used if the connected device does not provide its own power. The port is capable of accepting 250 mA, maximum.
- Digital input with pull-up disabled
 - Digital input is triggered by an external switch or voltage between the digital input pin and ground.
 - Example application, digital input without pull-up: occupancy sensor connection.

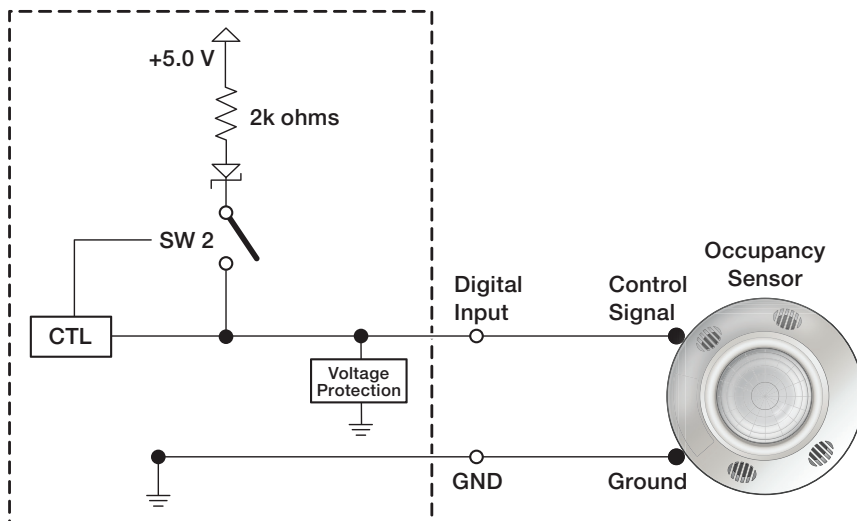

Figure 9. Occupancy Sensor, Without Pull-up

- Room occupied: digital input is +2.8 to 24 VDC, logic high.
- Room unoccupied: digital input is 0 VDC, logic low.

NOTE: Occupancy sensors typically supply +24 VDC (logic high) when occupancy is detected. After a set time with no occupancy, the sensor supplies 0 VDC (logic low).

- Digital input with pull-up enabled
 - The +5.0 VDC pull-up resistor is enabled (switch 2 is closed when configured for pull-up).
 - An external short to ground creates a logic low.
 - An open circuit acts a logic high.
 - Example application, digital input with pull-up: connecting a two-position switch.

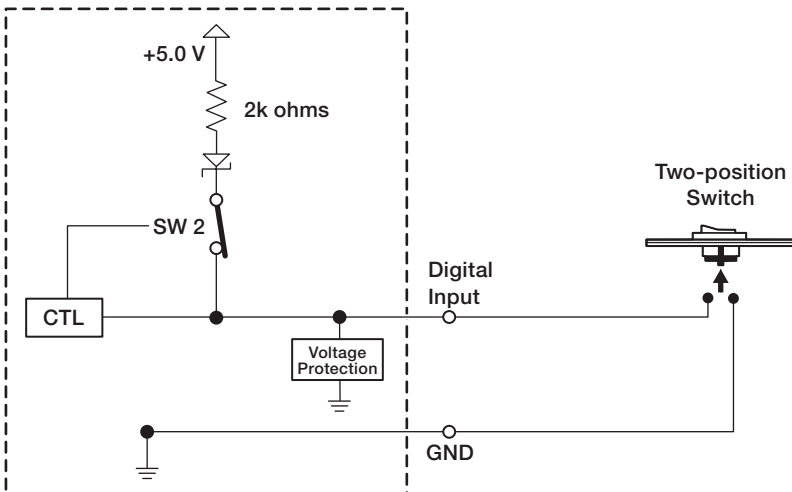

Figure 10. Two-position Switch With Pull-up

- Two-position switch is open: digital input is +5 VDC, logic high.
- Two-position switch is closed: digital input is 0 VDC, logic low.

Digital output — To activate LEDs, incandescent lights, or other devices that accept a TTL signal, or to provide contact closure control for projector lifts, motorized screens, room or light switches via an Extron IPA T RLY4 or similar device, use this port as a digital output. When a port is configured for digital output, it offers two output states: on and off.

- When the port is set to an On state, (the switch 1 circuit is closed), the I/O pin is connected to ground. Output voltage is less than 0.5 volts.
- When the port is set to the Off state (the switch 1 circuit is open), the output pin floats (is not connected).

- If the application calls for TTL compatibility, the digital output circuit can be set up to provide a pull-up resistor to +5 VDC, which you can use if the connected device does not provide its own power.
 - If the pull-up resistor is disabled, voltage output is determined by an external source device.
 - If the pull-up resistor is enabled, switch 2 is closed, voltage output is approximately 4.3 VDC.

Each I/O port is capable of accepting 250 mA, maximum.

- Digital output with pull-up disabled:
 - When switch 1 closes, the port is on.
 - When switch 1 opens, the port is off.
 - Example application, digital output without pull-up: connecting an LED and an external +5 VDC power source.

This application often requires a current-limiting resistor, as shown in the diagram below. Many button switches that contain LEDs have a resistor built in. See the guide for the lighted switch or stand-alone LED for details.

NOTE: Each I/O pin is capable of sinking a maximum of 250 mA.

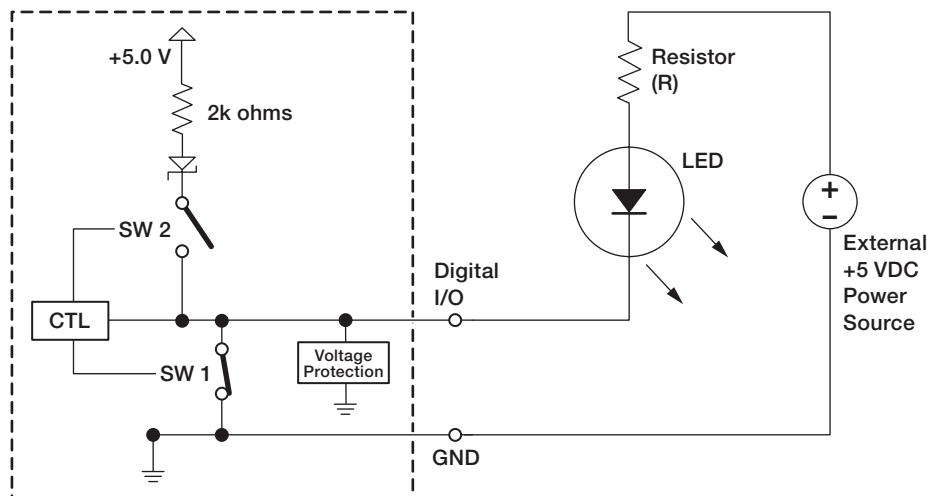

Figure 11. Digital Output Application: LED and External +5 VDC Power Source Without Pull-up

To determine the value of the current limiting resistor in the circuit shown above, you need to know the values of three variables:

i = LED forward current in amps (found in the data sheet for the LED)

V_f = LED forward voltage drop in volts (found in the data sheet for the LED)

V_s = supply voltage of the external voltage source

Insert those values into the following equation to determine the resistor value:

$$R = \frac{V_s - V_f}{i}$$

Example calculation:

$$i = 5\text{mA} (0.005\text{ A})$$

$$V_1 = 2\text{ V}$$

$$V_2 = 5\text{ V}$$

$$R = \frac{V_s - V_f}{i} = \frac{5\text{ V} - 2\text{ V}}{0.005\text{ A}} = 600\text{ ohms}$$

NOTE: If the value calculated for the current limiting resistor is not a standard resistor value, you can round up the number to the next highest common resistance value.

- The connected LED is off when the port and switch 1 are open.
- The connected LED is on when the port and switch 1 are closed.

- Digital output with pull-up enabled:
 - When the port is configured for pull-up, switch 2 is closed, activating the +5.0 VDC pull-up resistor.
 - When switch 1 closes, the port is on.
 - When switch 1 opens, the port is off.
 - Example application, digital output with pull-up: controlling another device via its contact closure input port.

Connect the digital I/O port to the contact input port of another device, such as an Extron DTP transmitter. When activated, the digital output port momentarily shorts pin 1 to ground (pulsed contact for 0.5 seconds), closes switch 1, which selects the input on the connected device.

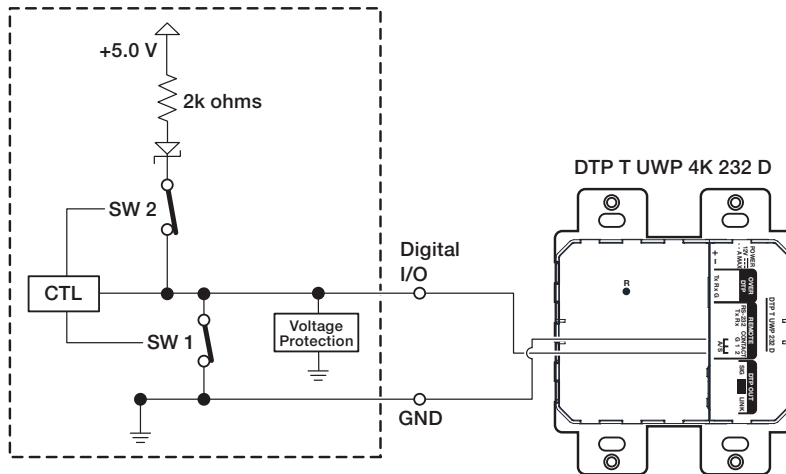
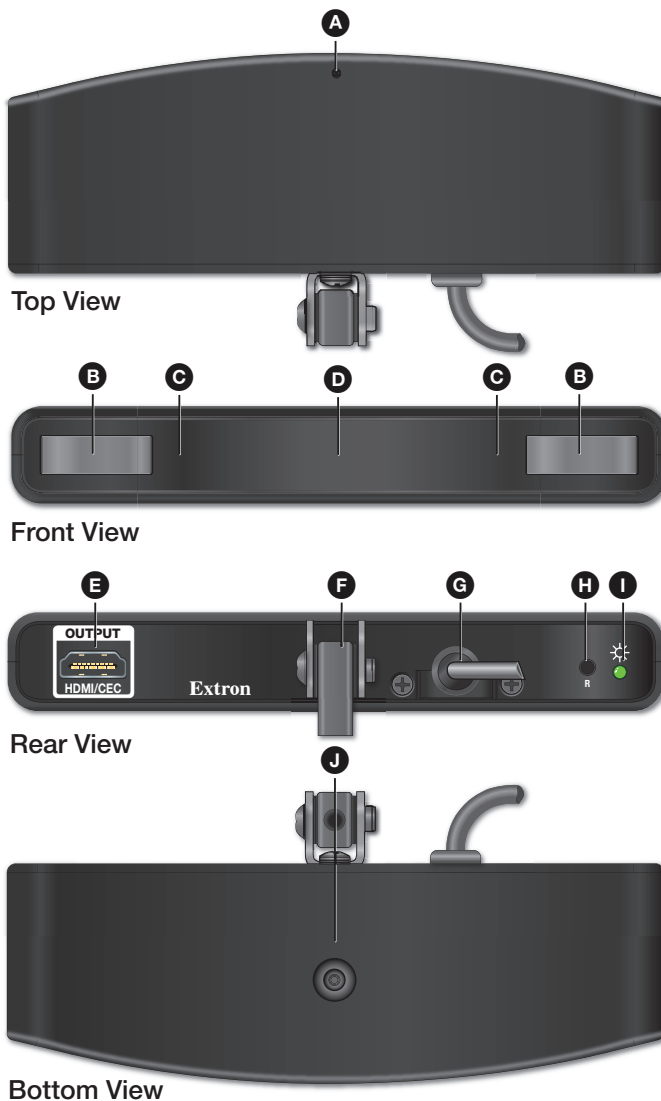

Figure 12. Digital Output Application With Pull-up: Contact Closure Input Selection on a Connected Device

Panel Features

Features and indications are described in this section.



- A** Acoustic sensor
- B** Left and Right Passive Infrared (PIR) sensors
- C** Left and Right PIR sensor red LEDs
- D** Acoustic sensor green LED

NOTE: The PIR sensor and acoustic sensor LEDs are behind the translucent front panel and are not seen until they light up.

- E** HDMI/CEC port
- F** Mounting post with included mounting bracket attached
- G** Port Expansion Interface cable
- H** Reset button
- I** Reset and power LED
- J** 1/4"-20 Universal female thread for mounting

Figure 13. WC Pro 150 OCS Panels

- A** **Acoustic sensor** — Detects occupancy based on sound.
- B** **Left and right passive Infrared (PIR) sensors** — Detect occupancy based on motion. See [Motion Sensor Coverage](#) on page 22 for details on the sensors.
- C** **Left and right PIR sensor red LEDs** — In discrete mode, the LED blinks when the PIR sensors detect motion (see [Occupancy Sensor Settings panel](#) on page 36 for more information on the modes). LED indicators are off by default and need to be enabled in Toolbelt or the internal web pages.

NOTE: The orientation of the left and right sensors and LEDs is based on the front view of the OCS.

- D** **Acoustic sensor green LED** — In discrete mode, the LED blinks when the acoustic sensor detects sound (see [Occupancy Sensor Settings panel](#) for more information on the modes). LED indicators are off by default and need to be enabled in Toolbelt or the internal web pages.

NOTE: The PIR sensor and acoustic sensor LEDs are behind the translucent front panel and are not seen until they light up.

- E HDMI/CEC port** (see [figure 13](#) on page 15) — Connect an AV device to the HDMI/CEC output port. If the CEC-compliant display supports CEC control, the WC can automatically turn display power on or off based on whether occupancy is detected.

About CEC control

Consumer Electronics Control (CEC) is an industry standard for control functions provided by HDMI. CEC control functions are incorporated into the WC Pro 150 OCS internal web pages and into GC software to control other equipment. HDMI CEC implementations vary by manufacturer and by their equipment.

Extron has tested a representative sample of equipment from other manufacturers to assure that power on and off commands work with most devices that conform to the HDMI CEC standard. However, CEC inter-operation between the WC and equipment from other manufacturers cannot be guaranteed. See the manual for the device that you want the WC to control to determine the details of the HDMI CEC functions for that product, and see the release notes for the Extron Universal Display Driver - HDMI CEC.

TIPS:

- If your display device does not support CEC commands or does not support a full implementation of them, use one of the other control options available in the WC, such as RS-232, IR, or Ethernet control.
- Some displays must be configured to enable CEC communication.

Automatic display power control

The WC Pro 150 OCS can automatically turn display power on or off based on whether occupancy is detected. The system uses CEC driver commands sent to the display to automatically turn display power on or off based on whether occupancy is detected.

WC Pro 150 OCS ships with basic CEC control built into the default configuration. Basic CEC controls in that configuration work out of the box, but can be further customized using Global Configurator or ControlScript software.

The CEC port configuration can specify whether or when to send the power-off command, and specify whether to send other CEC commands. See the *Global Configurator Help File* or *ControlScript Help File* for more detailed information on the port and on macros.

Supported CEC commands

CEC commands are derived from the CEC driver file, configured in Global Configurator, ControlScript, or included in the factory configuration. Actions configured in Global Configurator can tell the WC to send CEC commands to the HDMI output. The WC system supports the following CEC commands:

- power on
- power off
- connection status
- HDMI input switching
- show as active source
- volume up
- volume down
- audio mute toggle
- user-defined command
- user-defined string

NOTE: All these commands are not available for configuration via the Internal Web Page. Only Power On and Off command and control is used in the Internal Web Page.

For additional details, see the Comm Sheet for the Extron Universal CEC driver, available on the product pages on the Extron [website](#).

- F Mounting post with included mounting bracket attached** — See [Installation Step 7: Mounting](#) on page 18.
- G Port Expansion Interface cable** — See [Port Expansion Interface Connections and Cabling](#) on page 8.
- H Reset button** — Push this button to initiate one of the reset modes (see [Resetting the Unit](#) on page 20 for more information).
- I Reset and power LED** — The green LED blinks to indicate the reset mode and lights solid green when the unit is powered and in normal operation (see [Resetting the Unit](#)).
- J ¼"-20 universal female thread for mounting** — The WC Pro 150 OCS can be mounted on an optional standard camera or video universal mounting solutions using this universal mounting thread on the bottom of the device.

Installation Step 4: Set up Network Communication

1. Connect the PC used for setup and the WC Pro 150 OCS to the same Ethernet subnetwork. For LAN connections for the WC Pro 150 OCS, see [Control and power — LAN \(Ethernet\) and PoE](#) on page 8.
2. Start Global Configurator and use the Toolbelt feature of the software (or use the stand-alone Toolbelt program) to set the IP address, subnet, gateway IP address, DHCP status, and related settings. Network setup is essential prior to configuration. Use the flowchart on the right as a guide to setting up the controller for network use.

NOTE: A quick way to get the unit on your network is to press and release the **Reset** button 5 times to toggle (enable) DHCP on. From the factory it is disabled, with a static IP address. Once DHCP is enabled and the device is connected to the network, access the internal web page via `hostname.domain.com`, for example: `WC-PRO-150-OCS-xx-xx-xx.extron.com` (`xx-xx-xx` are the last three octets of the MAC address, located on the MAC address label on the device).

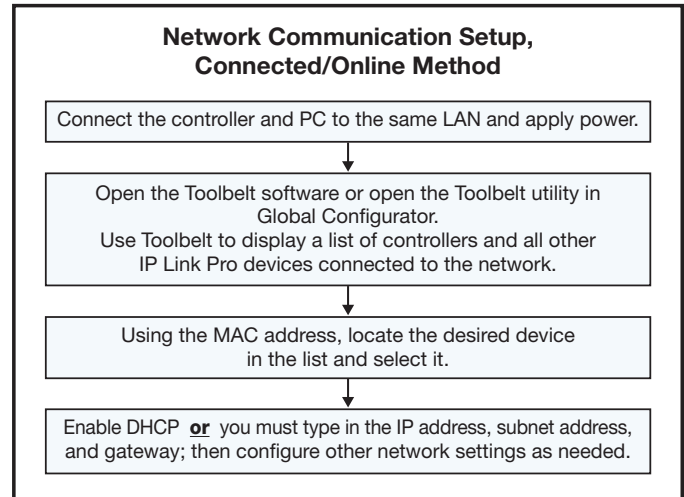

Figure 14. Network Setup, Online Method

Installation Step 5: Configure the WC Pro 150 OCS

The WC Pro 150 OCS is shipped preconfigured for CEC functionality with the digital output port 2 following the occupancy status.

The WC Pro also has internal web pages to configure and customize the functionality (see [Internal Web Page Configuration](#) on page 25).

Global Configurator or ControlScript provide advanced configuration of the WC Pro 150 OCS.

To create a custom configuration, follow the basic steps outlined below in the recommended order.

NOTE: See the *Global Configurator Help File* or *ControlScript Deployment Utility Help File* as needed for step-by-step instructions and detailed information. The help file for GC includes an introduction to the software, and how to start a project and configuration.

1. Using GC, create a new GC Plus or GC Professional project and configure the controller. The configuration tells the controller how its ports function, how to control other products, what to monitor, when to do things, and whom to notify, how, and under what circumstances.
 - a. Configure ports on the controller.
 - Select device drivers and link them to each assigned serial, IR, or Ethernet port.
 - Configure settings (serial protocol, digital input) as needed.
 - b. Set up monitors, schedules, macros, and local variables.
 - c. Add and configure user interface devices.
2. Save the project.
3. Build and upload the system configuration to the controller.

Installation Step 6: Test and Troubleshoot

1. Test the system.

If the controller is connected to a network, ensure that the yellow Activity LED and green Link LED on the LAN/PoE port light.

2. Make adjustments to wiring or configuration as needed.

Installation Step 7: Mounting

Prior to mounting:

1. The controller comes out of the box mounted to the long side of the bracket. Determine the desired depth from the wall.

NOTES:

- If it is preferred to have the controller mounted close to the wall, it is recommended that you switch the controller to the short side of the bracket.
- Do not use any other screw in the threaded hole in the mounting post of the WC Pro 150 OCS. The provided screw allows mobility of the controller without loosening the connection.
- Be sure the large metal washers are on the outside, against the post and the screw. The plastic delrin washers are on the inside, against the bracket.
- Use a Phillips screw driver to tighten the screw until snug, while allowing the unit to slide, tilt, and rotate on the bracket.

2. The port expansion interface hub is connected to the controller with a 3 feet (0.91 m) cable. Determine where and how it is to be mounted.
3. Disconnect power at the source from all devices in the system.

Mount the WC Pro 150 OCS as follows:

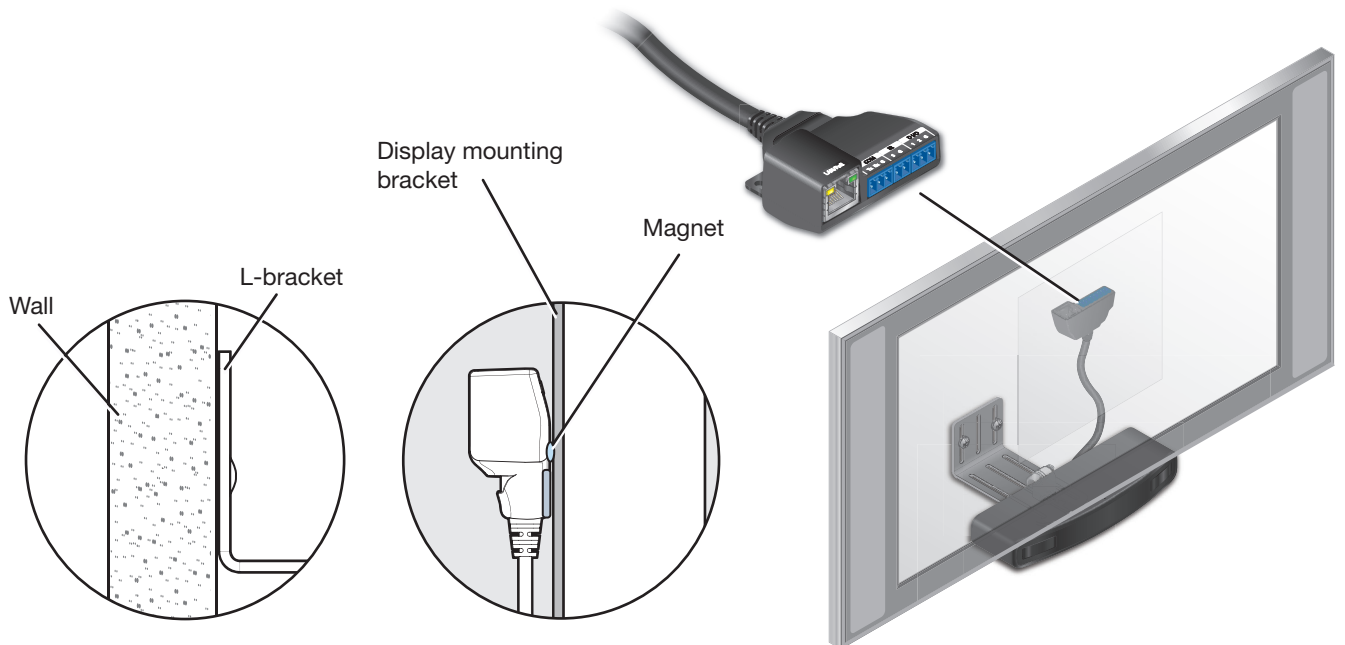

Figure 15. Mount the WC Pro 150 OCS

1. Secure the WC Pro 150 OCS above or below the display (see [figure 15](#) on page 18):
 - Using the L-bracket (see figure 16)
 - With device mounted on the long side of the L-bracket.
 - With the device mounted on the short side of the L-bracket.
 - Remove the L-bracket and mount the device using the 1/4"-20 universal female thread on the bottom of the device with an optional mounting accessory of choice. Use the instructions provided with your mounting accessory.
2. Secure the port expansion interface hub behind the display. There are three mounting options for the hub:
 - Attach the hub to a nearby metal surface via the molded-in magnets on the bottom.
 - Attach the hub to a bar or pole via zip ties threaded through the two slots and recessed groove around the interface hub.
 - Attach the hub to a rack post, wall, or wood via two screws through the two mounting slots.
3. Make all connections to the WC Pro 150 OCS port and expansion interface hub.
4. Connect power to the source to all devices in the system.

NOTE: The WC Pro 150 OCS is powered through the LAN port, so be sure to make that connection.

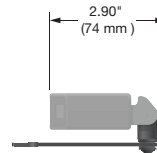
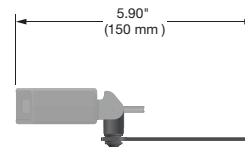
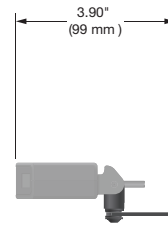

Figure 16. Mounting Bracket Dimensions (Side View)

Resetting the Unit

There are several reset modes available by pressing the **Reset** button. The green LED flashes depending on the selected reset mode (see the Reset Mode Summary table for details). The **Reset** button is recessed, so use an Extron Tweaker, a pointed stylus, or a ballpoint pen to access it.

ATTENTION:

- Review the reset modes carefully. Using the wrong reset mode may result in unintended loss of configuration, settings, port reassignment, or a unit reboot.
- Analysez minutieusement les différents modes de réinitialisation. Appliquer le mauvais mode de réinitialisation peut causer une perte inattendue de la programmation de la mémoire flash, une reconfiguration des ports ou une réinitialisation de l'unité.

NOTES:

- If the **Reset** button is held down continuously, the LED blinks every 3 seconds, and the unit enters a different mode, from the Reset all IP Settings mode through the Reset to Factory Defaults mode. For Reset to Factory Defaults mode the LED blinks three times, the third blink indicating the last mode. The modes are separate functions, not a continuation from one mode to the next.
- The factory configured passwords for all accounts on this device have been set to the device serial number. In the event of a complete system reset, the passwords convert to the default, which is extron.

Reset Mode Summary			
Mode	Use This Mode to...	Activation	Result
Reset All IP Settings	Reset IP settings and port maps to factory defaults without affecting user-loaded files	To reset all IP settings: <ol style="list-style-type: none"> 1. Hold down the Reset button for about 6 seconds until the Reset LED blinks once at 3 seconds and twice at 6 seconds. 2. Release and momentarily press and release the Reset button (for <1 second) within 1 second*. <p>*Nothing happens if the momentary press does not occur within 1 second.</p>	Reset All IP Settings mode: <ul style="list-style-type: none"> • Sets the IP address back to factory default (192.168.254.250) • Sets the subnet back to factory default (255.255.255.0) • Sets the default gateway address to the factory default (0.0.0.0) • Sets domain and host names to factory default. • Sets port mapping back to factory default. • Turns DHCP off. • Turns events off (user-created schedules, macros). • Stops any running program.
Run Universal Boot Code	Temporarily boot up the unit running only the universal boot code, then install the desired firmware. Use this in the event that a firmware update has failed or if incompatibility issues arise with userloaded firmware.	To start the Run Universal Boot Code reset mode and replace firmware: <ol style="list-style-type: none"> 1. Hold down the recessed Reset button while applying power to the unit. Hold the button down until the Reset LED blinks twice, then release the button. The controller enters factory firmware mode, and the LED blinks quickly- 2. Upload new firmware to the unit as desired (see Updating the Firmware on page 47 for details). <div style="border: 1px solid black; padding: 5px; margin-top: 10px;"> <p>NOTE: Do not continue to operate the control processor using only the boot code. The unit requires a full firmware package in order to be fully operational. If you want to use the firmware version with which the unit shipped, you must upload that version again (see the <i>Global Configurator Help File</i> or <i>Toolbelt Help File</i> for instructions).</p> </div>	The control processor firmware is replaced. If the unit is powered on in Run Universal Boot Code mode, event scripts and systems do not start. All user files and settings such as drivers, adjustments, and IP settings are maintained. <div style="border: 1px solid black; padding: 5px; margin-top: 10px;"> <p>NOTE: To return the unit to the firmware version that was running prior to the reset, cycle power to the unit.</p> </div>

Reset Mode Summary			
Mode	Use This Mode to...	Activation	Result
Reset to Factory Defaults	Start over with configuration and uploading	<p>To reset the unit to all factory default settings:</p> <ol style="list-style-type: none"> 1. Hold down the Reset button for about 9 seconds until the Reset LED blinks once at 3 seconds, twice at 6 seconds, and three times at 9 seconds. 2. Release and momentarily press and release the Reset button (for <1 second) within 1 second*. <p>*Nothing happens if the momentary press does not occur within 1 second.</p>	<p>Reset to Factory Defaults mode performs a complete reset to factory defaults (except the firmware).</p> <ul style="list-style-type: none"> • Does everything Reset All IP Settings mode does. • Reverts back to the factory pre-configured functionality with CEC. • Removes all user-loaded files and configurations from the controller: <ul style="list-style-type: none"> • Clears driver-port associations (IR, serial, Ethernet) and port configurations. • Removes button configurations. • Removes schedules, settings, macros.
Project Recovery	Recover GCP project configuration and program files if passwords have been lost	<p>To start the Project Recovery reset mode and recover a project:</p> <ol style="list-style-type: none"> 1. On the PC, open Global Configurator. 2. Click the Tools menu and select Project Recovery. The Recovery Mode dialog box opens. 3. Enter the IP address or host name of the target device for which you want to perform project recovery. 4. Click Recover. The software allows indefinite time to establish a connection (until a connection is made or the user clicks Cancel). 5. On the control processor, press the Reset button three times within 1 second. The control processor enters project recovery mode for 30 seconds, during which time the Power LED blinks quickly. GC automatically connects to the control processor, then opens and retrieves the project from the unit. 6. Perform the Reset to Factory Defaults reset on the control processor. 7. Open Toolbelt, start device discovery, select the desired control processor from the list, and click Manage. 8. Click the Network Settings tab and set the IP address of the control processor. 9. Click the User Management tab and change the password of the control processor. 10. Close Toolbelt. 11. In GC, add the new password to the recovered project. 12. Save the project. 13. Upload the project from GC to the control processor. 	<p>Project Recovery mode stops regular operation and allows a connection to be made to the unit via GCP software without requiring password entry so that project files can be retrieved and saved.</p> <ul style="list-style-type: none"> • During project recovery mode, events are stopped, and so is communication with AV devices. • While the control processor is in this mode, use the software to recover project files. • Upon exiting project recovery mode: <ul style="list-style-type: none"> • The unit returns to its pre-recovery mode state and settings. • The Power LED returns to being steadily lit.
Run/Stop Program	Toggle stop/start program	<p>To stop or start a program:</p> <ol style="list-style-type: none"> 1. Hold down the Reset button for about 3 seconds, until the Reset LED blinks once. 2. Release and press the Reset button momentarily (for <1 second) within 1 second*. <p>*Nothing happens if the momentary press does not occur within 1 second.</p>	<ul style="list-style-type: none"> • The LED blinks 2 times if the program is starting. • The LED blinks 3 times if the program is stopping.
Toggle DHCP	Enable or disable the DHCP client	<p>To enable or disable the DHCP client for the LAN port:</p> <ol style="list-style-type: none"> 1. Press the Reset button five times (consecutively). 2. Release the button. Do not press the button within 3 seconds following the fifth press. 	<ul style="list-style-type: none"> • The Reset LED blinks 6 times if the DHCP client is enabled. • The Reset LED blinks 3 times if the DHCP client is disabled.
<p>NOTES:</p> <ul style="list-style-type: none"> • By default, DHCP is off and the unit uses a static IP address. • When DHCP is disabled, the unit uses the factory default IP address (192.168.254.250), or the previously stored static IP address if it was not at default. 			

Motion Sensor Coverage

The WC PRO 150 OCS covers standard small, medium, and large conference rooms with the controller mounted below a display (4 feet [1.22 m] from the floor).

Figure 17 shows the side field of view of the sensor coverage. The two colors indicate the major and minor movement that triggers the PIR sensors.

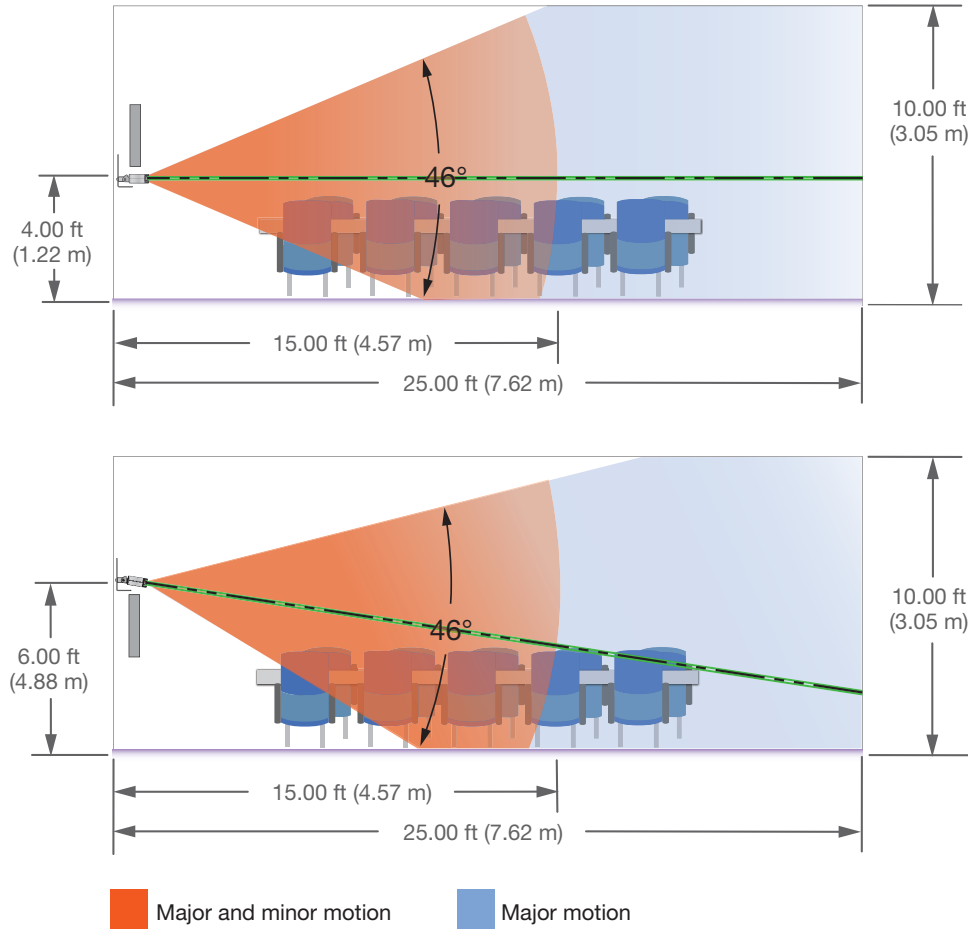

Figure 17. WC Pro 150 OCS PIR Sensor Coverage in a Conference Room from a Side View

Figure 18 and [figure 19](#) on page 24 show the top field of view of the sensor coverage. In figure 18, the two colors indicate the individual left and right PIR sensors coverage that overlap in the middle. In the event that one of the two sensors is disabled, only the field of view for the remaining sensor would apply.

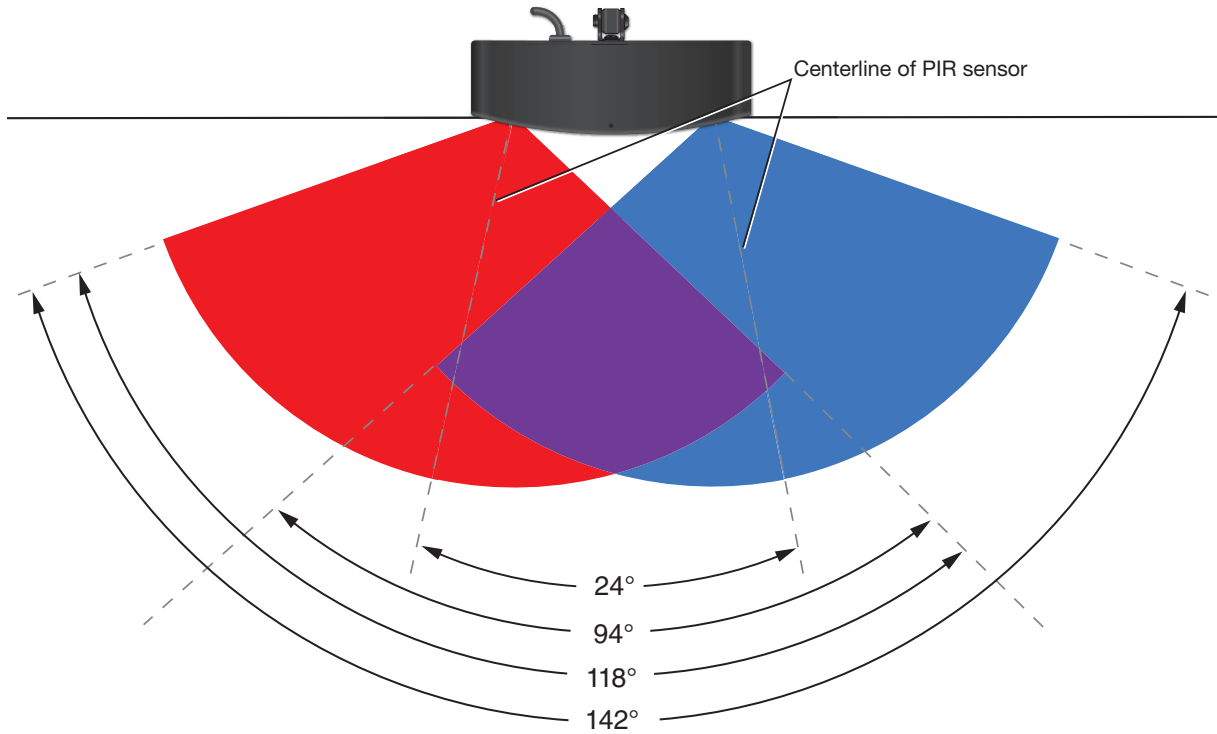

Figure 18. WC Pro 150 OCS PIR Sensor Coverage from a Top Down View

In figure 19, the two colors indicate the major and minor movement that triggers the PIR sensors.

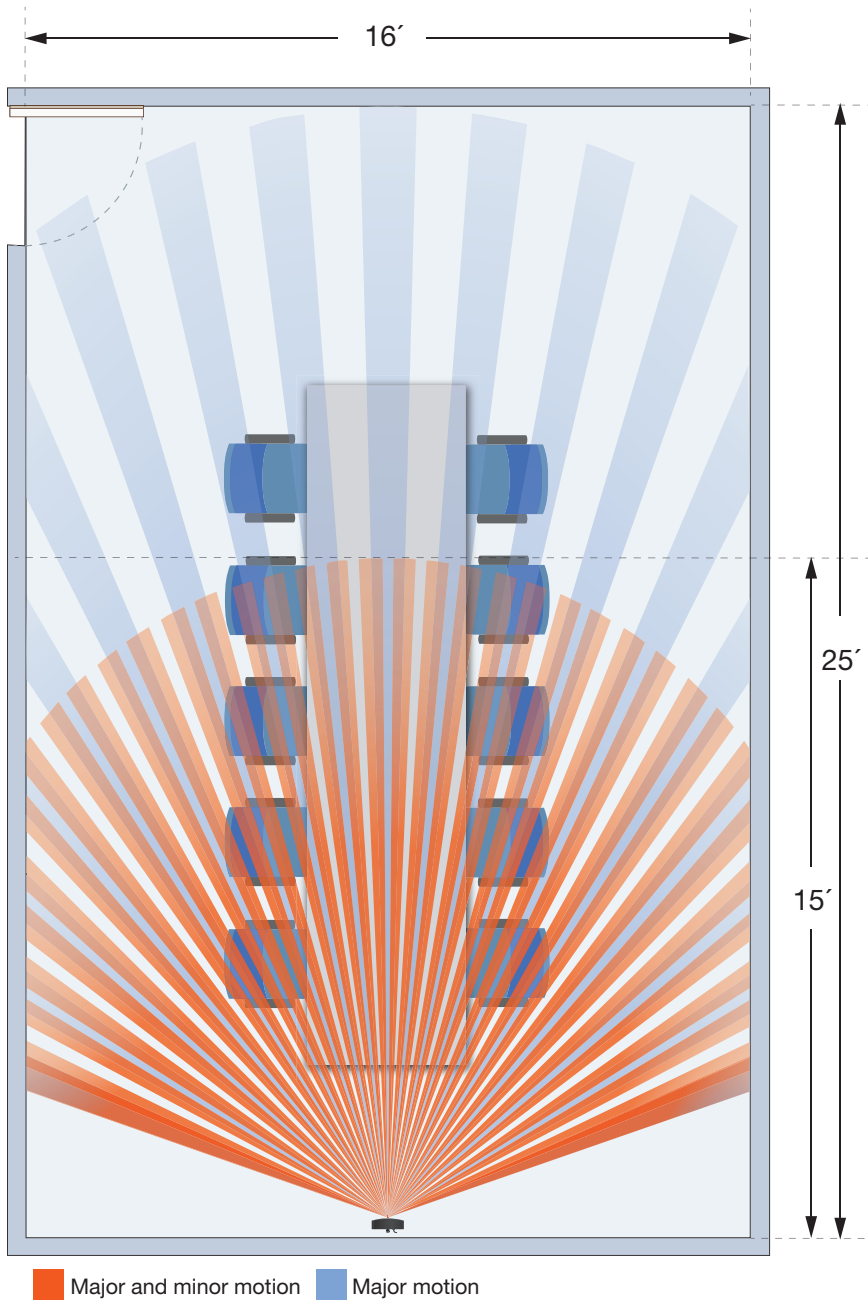

Figure 19. WC Pro 150 OCS PIR Sensor Coverage in a Conference Room from a Top Down View

Internal Web Page Configuration

The WC Pro 150 OCS workspace automation controller features internal web pages. Configure and monitor certain settings of the WC Pro device via a LAN connection. Use a web browser to view the pages on a PC or any other mobile device connected to the device LAN port or the same network.

This section gives an overview of the internal web page. Topics in this section include:

- [Accessing the Internal Web Page](#)
- [Configuration with the Web Pages](#)

Accessing the Internal Web Page

Access the WC Pro internal web page as follows:

1. Connect the WC Pro device to a LAN using the RJ-45 LAN port (see [figure 3](#) on page 8).
2. Open a web browser on a PC connected on the same LAN.

NOTE: Compatible web browsers are Microsoft® Edge®, Mozilla® Firefox®, Google Chrome™, and Apple® Safari®.

3. Enter the WC Pro IP address or hostname in the browser **Address** field.

NOTE: If the local system administrators have not changed the value, the factory-specified default is 192.168.254.250 for the LAN port or the default hostname, WC-Pro-150-OCS-xx-xx-xx or with a LinkLicense, WC-PRO-150-OCS-with-linklicense (-xx-xx-xx the last three octets of the MAC address).

4. Press the <Enter> key on the keyboard. The sign-in web page opens.

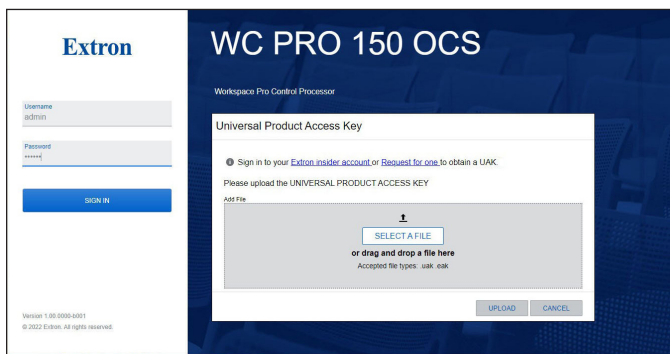

NOTES:

- If this is the first time accessing the Internal Web Page, the Universal Access Key (UAK) dialog opens on top of the web page.
- If the LinkLicense for WC Pro Control Processor was purchased and uploaded in Toolbelt prior to opening the Internal Web Page, the device opens directly to the login page. A UAK is not needed.

Figure 20. Network Password Prompt

To access the WC Pro with the UAK:

- a. Select **Extron insider account** to sign in. If you do not have an Extron insider account, select **Request for one**. These links open a page on the Extron website.
- b. Once signed in to the Extron insider account, click the **Universal Access Key** link.
- c. Click **Retrieve a New Universal Access Key** to download a UAK file or go to www.extron.com/uak.
- d. Once the UAK file is downloaded, either click **SELECT A FILE** to upload, or drag and drop the file to the **Add File** pane.

NOTE: If an Insider account holder obtains a UAK file, it expires in 90 days. If a guest account holder obtains a UAK file, it expires in 7 days. After expiration, the user needs to obtain a new UAK file.

5. The WC Pro is password protected. Enter **admin** or **user** in the **Username** field and the password in the **Password** field when prompted (see figure 20).

NOTE: The factory configured passwords for all accounts on this device have been set to the device serial number. In the event of a complete system reset, the passwords convert to the default, **extron**.

6. Click the **SIGN IN** button.

Configuration with the Web Pages

The WC Pro 150 OCS internal web page opens to the Device Utilities page (see figure 21) that provides a read-only view of the general Device Details and Unit Status of the WC Pro 150 OCS, with some configuration panels, pages, and buttons for the date and time, network connections, passwords, firmware update, sensor settings and display control, backup, restore, reboot, and reset the unit. The panels that can be edited have an **EDIT** link to click to access the panel.

NOTES:

- If the unit has been configured with GCP, the internal web page is view only. Settings cannot be changed. To go back to web configuration mode, reset the unit.
- If logged in as a user, the pages are view only and settings cannot be changed.

The Device Utilities page has the following tabs, status panels, and drop-down panels:

- 1 **Device Detail Panel**
- 2 **Unit Status Panel**
- 3 **Backup, Restore, Reboot, and Reset Links**
- 4 **Network Panel**
- 5 **Date and Time Panel**
- 6 **Roles and Permissions Panel**
- 7 **Firmware Panel**
- 8 **Display Control Page**
- 9 **Sensor Page**

The drop-down panels and tabs are accessed by clicking on the name of the panel or the arrow next to the name. To view general information about the WC Pro 150 OCS, click the **ABOUT** link (10 see [About the WC Pro 150 OCS](#) on page 38).

NOTE: If the LinkLicense for WC Pro Control Processor was purchased and Global Configurator Plus and a Global Configurator Professional (GCP) file was configured and uploaded to the device, the pages are view only and the left side navigation tabs are not available. All configuration must be done using GCP. To return the device to web based configuration, reset the unit to remove the GCP configuration file.

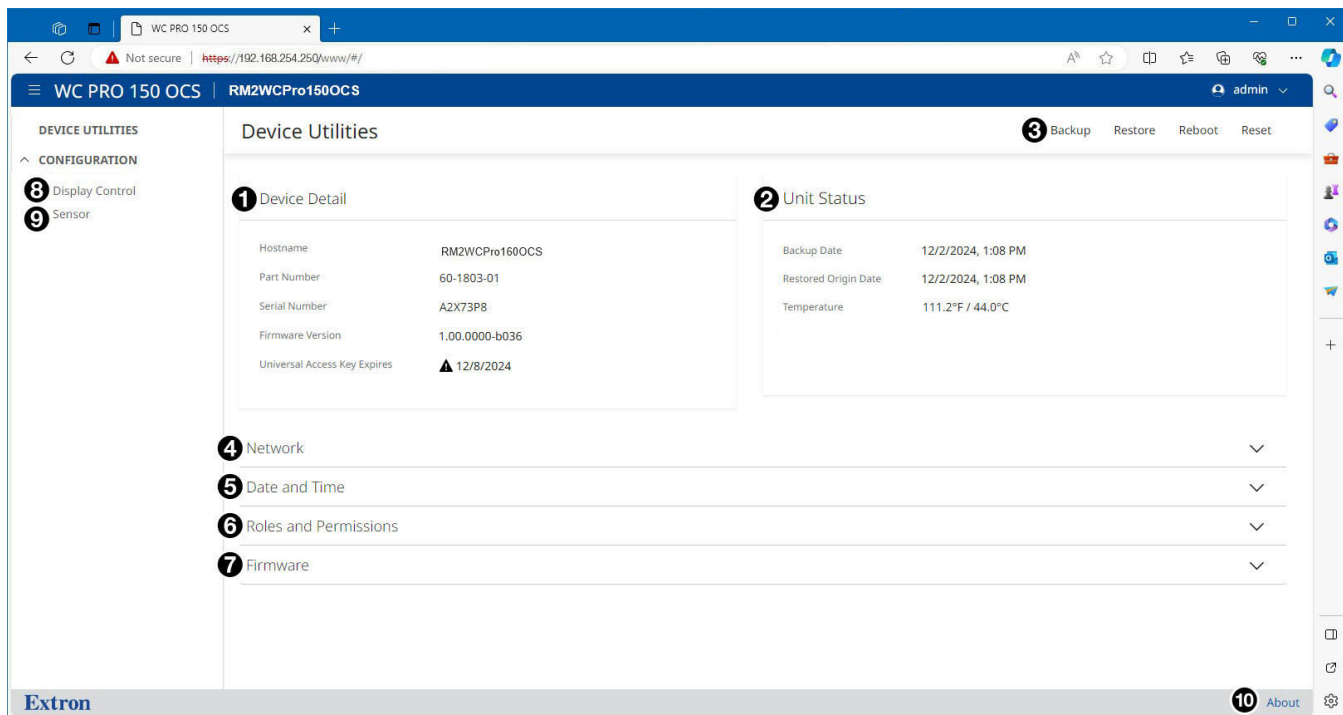

Figure 21. WC Pro 150 OCS Internal Web Page

Device Detail Panel

The Device Details panel (see [figure 21](#), [1](#) on page 26) displays the hostname, part number, serial number, firmware version number, and expiration date of the Universal Access Key (only if the device does not have a LinkLicense).

Unit Status Panel

The Unit Status panel ([2](#)) displays the date of the last backup , restored origin date, and device temperature.

Backup, Restore, Reboot, and Reset Links

These utility links ([3](#)) allow the user to create a backup file of the configuration, restore a backup configuration to the device, reboot, or reset the device.

- **Backup** — When this link is clicked, the device creates a backup file and a confirmation dialog opens in front of the page. The device file is saved as a .cfg file.
- **Restore** — When this link is clicked, a Restore dialog opens in front of the page to browse to the backup file to select. After the file is selected, click **RESTORE** to continue or **CANCEL** to quit the restore.

Note: The following are backed up or restored on the device:

- Everything in the Display Control section
 - Sensor settings
 - Date and time settings in the Device Utilities section
- **Reboot** — When this link is clicked, a Reboot Device? dialog opens in front of the page to confirm the reboot. Click **REBOOT** to continue or **CANCEL** to quit the reboot. A reboot restarts the device.
 - **Reset** — When this link is clicked, a System Reset dialog opens in front of the page to confirm the reset. Click **RESET** to continue or **CANCEL** to quit the reset. Resets all settings and deletes all user loaded content on internal storage, while retaining TCP/IP settings. Reverts back to the default factory configuration and functionality

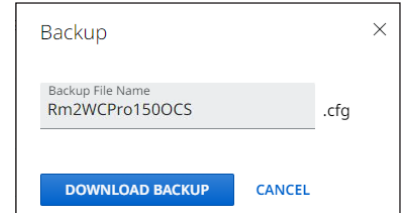

Backup

Backup File Name
Rm2WCPro150OCS .cfg

DOWNLOAD BACKUP CANCEL

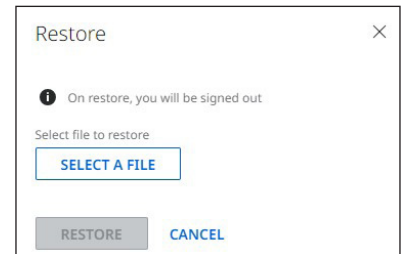

Restore

On restore, you will be signed out

Select file to restore

SELECT A FILE

RESTORE CANCEL

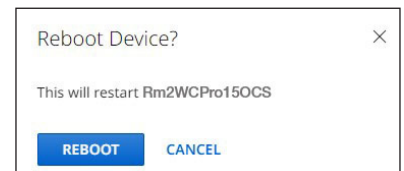

Reboot Device?

This will restart Rm2WCPro150OCS

REBOOT CANCEL

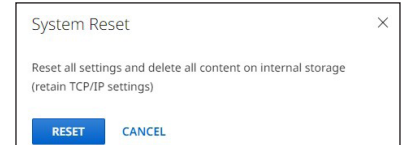

System Reset

Reset all settings and delete all content on internal storage
(retain TCP/IP settings)

RESET CANCEL

Network Panel

In the Network panel (see [figure 21](#), [4](#) on page 26), change the device name (hostname) and edit the IP address, subnet mask, gateway address, DNS server, and search domain name for the WC Pro 150 OCS, or turn DHCP **On** and **Off**.

NOTE: The user can change the name and set the IP addresses all at once before clicking **SAVE** at the end of the process.

To change the name:

1. Click **EDIT** in the Network panel. The editable fields are displayed (see figure 22).
2. Edit the **Device Name / Hostname** as desired.
3. When finished editing, click **SAVE** to confirm your changes or **CANCEL** to close the window without making changes.

To set the IP addresses:

1. Click **EDIT** in the Network panel. The editable fields are displayed (see figure 22).
2. Edit the network settings as desired:
 - a. Click the **DHCP** switch to toggle DHCP on and off. When DHCP is enabled (On), the unit configures its IP address and other network settings from the DHCP server. The default is Off.
 - b. To set any of the addresses: **IP Address**, **Subnet Mask**, and **Default Gateway** address, **DNS Servers**, and **Search Domain** click in the desired field and enter the address.
3. When finished editing, click out of the field and click **SAVE** to confirm your changes or **CANCEL** to close the window without making changes.

Device Name / Hostname	RM2WCPro150OCS
MAC Address	00-05-A6-2A-5B-75
Configure IP	Static
IP Address	192.168.254.254
Subnet Mask	255.255.255.0
Gateway	0.0.0.0
DNS Server	
DNS Server 1	
DNS Server 2	
DNS Server 3	
Search Domain	

Figure 22. Network Panel

Date and Time Panel

The Date and Time panel (see [figure 21](#), ⑤ on page 26) displays the mode used to set the date and time, the current date, and current time. There are two options to set the date and time: manual mode and sync to NTP (Network Time Protocol) servers.

To set the date and time in manual mode:

1. Click **EDIT** in the Date and Time panel. The editable fields are displayed (see figure 23).
2. Select the **Manual** radio button.
3. Edit the **Date/Time** as desired by typing in the date and time or using the calendar and clock.
4. Edit the **Time Zone** as desired using the drop-down list.
5. When finished editing, click **SAVE** to confirm your changes or **CANCEL** to close the window without making changes.

Alternatively, click **SYNC TO PC** to set the date and time according to your PC.

To set the date and time in sync to NTP servers mode:

NOTE: There are three NTP address fields to ensure that if any of the NTP servers is down or not available the device re-attempts with the next NTP server in priority order.

1. Click **EDIT** in the Date and Time panel. The editable fields are displayed (see figure 24).
2. Select the **Sync to NTP Servers** radio button.
3. Click in an **NTP Server** field and enter the IP address or host name of a desired NTP Server.
Alternatively, click **SYNC TO NTP SERVER** to set the date and time according to the set NTP Server.
4. When finished editing, click **SAVE** to confirm your changes or **CANCEL** to close the window without making changes.

The screenshot shows the 'Set Date & Time' configuration window. At the top, the title is 'Set Date & Time'. Below the title are two radio buttons: 'Manual' (which is selected) and 'Sync to NTP Servers'. Underneath, there is a 'Date | Time' field displaying '01/02/24 10:36 PM' with a calendar icon and a clock icon. Below that is a 'Time Zone' dropdown menu showing '(UTC+00:00)'. At the bottom, there are three buttons: 'SAVE', 'SYNC TO PC', and 'CANCEL'.

Figure 23. Manual Mode

The screenshot shows the 'Set Date & Time' configuration window in 'Sync to NTP Servers' mode. The title is 'Set Date & Time'. Below the title are two radio buttons: 'Manual' and 'Sync to NTP Servers' (which is selected). Underneath is a 'Time Zone' dropdown menu showing '(UTC+00:00)'. Below that are three text input fields for NTP servers: 'NTP Server #1' containing 'time.nist.gov', 'NTP Server #2', and 'NTP Server #3'. At the bottom, there is a 'Current Date & Time' field displaying 'Jan 3, 2024, 4:51:16 PM'. At the very bottom, there are three buttons: 'SAVE', 'SYNC TO NTP SERVER', and 'CANCEL'.

Figure 24. Sync to NTP Servers Mode

Roles and Permissions Panel

The Roles and Permissions panel (see [figure 21](#), ⑥ on page 26) displays whether Admin and User passwords have been set and provides an option to set administrator or user passwords. It does not display the actual password.

NOTE: The following rules apply to passwords:

- Length is 1-128 characters.
- All human-readable characters are permitted except |.
- The password cannot be a single space.
- Passwords are case-sensitive.
- If the device is reset, the Admin or User password defaults to **extron**.
- The factory configured passwords for all accounts on this device have been set to the device serial number. In the event of a complete system reset, the passwords convert to the default, which is **extron** for the Admin and User.

To assign an administrator and user passwords:

1. Click **EDIT** in the Roles and Permission panel. The editable fields are displayed (see figure 25).

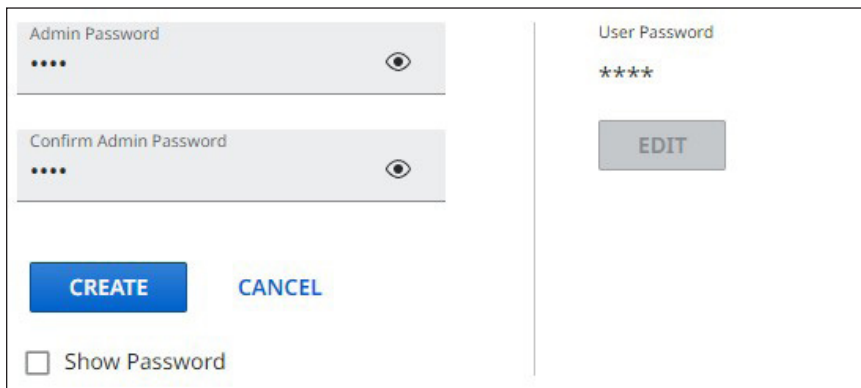

The screenshot shows a web interface for setting passwords. On the left, there are two input fields: 'Admin Password' and 'Confirm Admin Password', both containing four dots and a toggle icon. Below these are 'CREATE' and 'CANCEL' buttons. At the bottom left is a checkbox labeled 'Show Password'. On the right, there is a 'User Password' field with four stars and an 'EDIT' button.

Figure 25. Roles and Permissions Panel

2. Click in the **Admin Password** field and enter the new administrator password.
3. Click in the **Confirm Admin Password** field and enter the new password from the Admin Password field.
4. To assign a **User Password**, repeat steps 2 and 3 in the User Password panel.
5. When finished, click **CHANGE** to set the passwords. To close the window without saving a password, click **CANCEL**.

NOTE: Passwords can be changed but they cannot be removed entirely. The WC Pro 150 OCS must have passwords at all times. These fields cannot be blank.

Firmware Panel

The Firmware panel (see [figure 21](#), [7](#) on page 26) displays the current firmware version, the web version (version of the internal web pages) and the date it was last updated. Update the firmware on the WC Pro 150 OCS from this panel (see [Downloading the Software and Getting Started](#) on page 41 to download the firmware files).

To update firmware:

1. In the Firmware panel, click the **SELECT FILE** button.
2. In the Open dialog box, browse to locate the new firmware file on your computer (by default the file is usually stored at C:\Program Files (x86)\Extron\Firmware\WC Pro 150 OCS after being downloaded from the Extron website).

NOTE: Firmware file for WC Pro 150 OCS has an .eff extension.

3. Double-click the firmware file name. The Open window closes, and the selected firmware file name appears in the Update Firmware panel on the web page.
4. Click **INSTALL** to begin. During the updating process, a window appears in the middle of the screen, showing messages giving the progress of the update: Initializing, Installing the Firmware, and Rebooting Device.

NOTE: Do not close the browser while the firmware update is in progress.

When the update is completed, the message window closes and the message Firmware Upload Complete appears near the top of the screen. The new firmware filename appears under Current Version in the Firmware panel.

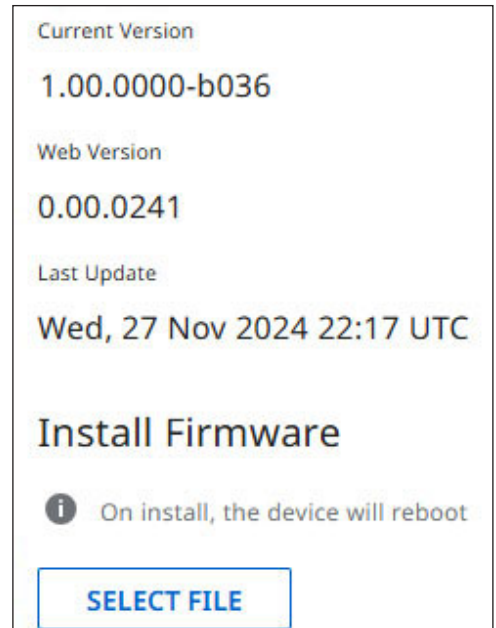

Figure 26. Firmware Panel

Display Control Page

NOTE: If the LinkLicense for WC Pro Control Processor was purchased and a GCP file was configured and uploaded to the device, these pages and the left side navigation tabs are not available. All configuration must be done using GCP and Toolbelt software. To return the device to web based configuration, reset the unit.

The Display Control page has three tabs to connect a display, turn power on and off via the occupancy sensor, and create schedules to turn the display on and off. When the **Display Control** tab (see [figure 21](#), ③) is selected, the page opens to the Connection panel.

The screenshot shows the 'Display Control' page for the 'WC PRO 150 OCS' device. The page is divided into three tabs: 'CONNECTION', 'POWER SETTINGS', and 'SCHEDULES'. The 'CONNECTION' tab is active. The 'Current Driver' section displays the following parameters:

Make	Model	Connection Type	Version	Baud Rate	Data Bits	Stop Bits	Parity	Flow Control
NEC	P702	Serial	1.0.1	9600	8	1	None	None

Below the 'Current Driver' section is a table of '30055 Drivers' with the following columns: Make, Model, Connection Type, Version, Tag, and Actions. The table lists several drivers with 'SELECT' buttons for each.

Make	Model	Connection Type	Version	Tag	Actions
3M	X90	Ethernet	1.0.0		SELECT
3M	X90	Serial	1.0.0		SELECT
3M	X31	Serial	1.0.0		SELECT
3M	X31	Ethernet	1.0.0		SELECT
3M	X36	Serial	1.0.0		SELECT
3M	X36	Ethernet	1.0.0		SELECT

A 'Communication Sheet' download button is also visible on the right side of the page.

Figure 27. Display Control Page

Connection page

The Connection page displays the drivers that have been pre-loaded to the device and provides fields to import and configure the drivers. The device comes pre-loaded from factory with the latest Extron display and video projector type drivers in serial, Ethernet, IR, and CEC interface types. If there are new or updated drivers, not in the available list, go to the [Extron Web-Base Automation Drivers page](#) to download individual drivers and import them into the device.

Current Driver

The driver that is currently enabled is displayed at the top of the page. Only one driver can be active at a time.

To change the parameters for the current driver:

1. Click the **EDIT** link, and the EDIT pane opens on the right side.
2. Enter the parameters in the available fields.
3. Click **CONFIRM** to complete the process or **CANCEL** to close the dialog without changing the parameters.

To remove a driver, click the **REMOVE** link.

Communication Sheets

Communication Sheets are available for download on every CEC, Ethernet, and serial driver (not IR) for general assistance with the display device setup and information.

NOTE: IR drivers do not have communication sheets.

Importing and navigating drivers

Icons and links to search, filter, and import drivers are in the right corner of the page above the list of drivers.

To search for a driver, click the magnifying glass icon and enter the name, model, version number or type of the desired driver. You can also search by the tag **import** or **current driver**.

To sort the columns, click on the desired column name and select the up or down arrow to list them alphabetically.

To narrow the list of drivers to a selection:

1. Click **Filter** and the Filter By pane opens on the right.
2. Select the desired variables from **Make**, **Model**, **Connection Type**, and **Device Tag**.
3. Click **VIEW RESULTS** to see the filtered list or **CANCEL** to close the pane without implementing the filter.

To import a driver:

NOTE: Go to the [Extron Web-Base Automation Drivers page](#) to download individual drivers and import them into the device. These are not the same as the GCP drivers.

1. Click **Import**. Import A New Driver dialog opens.
2. Click **SELECT A DRIVER** or drag and drop a driver from a folder containing downloaded drivers on the connected PC.
3. Click **IMPORT** to complete the process or **CANCEL** to close the dialog without importing the driver.
4. A confirmation message banner posts at the top of the driver page and an Imported tag posts in line with the newly imported driver.

Selecting a driver

Selecting drivers allows the user to select a driver from the available list of display or video projector devices to connect with. Only one driver can be selected.

NOTES:

- Web-based automation drivers for CEC, Ethernet, and serial interface are .pkj files. IR interface drivers are .eir files.
- The Repeat IR on Power Down feature is only available for IR drivers and is disabled by default. When selecting or editing an IR driver this feature can be enabled. When enabled, this feature repeatedly sends the power off command twice. This is used for certain type of devices (such as video projectors) that require a confirmation by sending a power command twice in order to turn off the device.

To select a driver:

1. Click **SELECT** in the row of the desired driver. The Drivers Settings dialog opens.
2. Fill in fields for the connection parameters of the device. The parameters vary depending on the type of driver or what options a specific driver supports, such as baud rates, username, and password.
Default values are pre-populated based on the specific driver selected. For example default baud rates for serial, port number for Ethernet, username, or password support.
3. Click **CONFIRM** to complete the process or **CANCEL** to close the dialog without adding the driver.
4. A confirmation message banner posts at the top of the driver page with a message that the driver was successfully added.

Editing a driver

Once a driver has been selected, it is displayed at the top of the page in the Current Driver pane. This driver can be edited or removed.

To edit a driver:

1. Click **EDIT** in the Current Driver pane. A Current Driver pane opens on the right side. The driver connection parameters can be edited in this pane.
2. Edit the driver parameters by filling in the populated fields. The parameters vary depending on the type of driver.
3. Click **CONFIRM** to complete the process with the updated information or **CANCEL** to close the dialog without editing the driver.

To remove a driver:

1. Click **REMOVE** in the Current Driver pane. A Remove Driver? dialog opens.
2. Click **REMOVE** to remove the driver. The dialog closes and the driver is removed from the Current Driver card panel. This does not delete the driver from the device, it is removed as the active or selected driver.
Alternatively, click **CANCEL** to close the dialog without removing the driver.

Deleting an imported driver from the device

Deleting drivers allows the user to delete any driver that has been imported to the controller.

Note: Only drivers that have been imported to the controller can be deleted. Extron loaded factory drivers cannot be deleted.

To delete a driver:

1. Click **DELETE** in the row of the desired driver. The Delete Driver? dialog opens.
2. Click **DELETE** to complete the process or **CANCEL** to close the dialog without deleting the driver.
3. A confirmation message banner posts at the top of the driver panel with a message that the driver was successfully deleted.

Power Settings page

Configure the WC Pro 150 OCS to enable display power on or off automation based on the room occupancy status detected from the integrated occupancy sensors. Toggle the switches to automate powering of the display on and off based on the room occupancy. **Default** is both enabled, so the integrated occupancy sensor status turns the display on and off based on the room occupancy status.

Test buttons help verify or troubleshoot display power on or off functionality by sending the power on or power off command to the device once the test button is clicked.

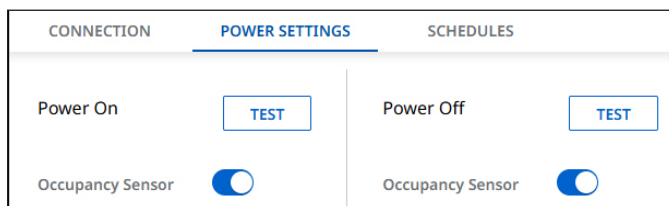

Figure 28. Power Setting Panel

Schedules page

Create schedules to automate the powering of the display on and off at selected times and days of the week.

To add a schedule:

1. Click **ADD SCHEDULE** from the Schedules page and the ADD SCHEDULE pane opens on the right side (see figure 29).
2. Enter a name for the desired schedule in the **Schedule Name*** field.
3. Select the **ON** or **OFF** radio button in the **Display Control*** field for the action desired for this schedule.
4. Enter the desired time for this schedule to occur in the **Time*** field or click on the clock icon.
5. Select the radio button for the day or days of the week for this action to take place in the **Select days to apply schedule*** field.
6. (Optional) Add a description of the schedule.
7. When finished, click **SAVE** to set the schedule. To close the window without saving the schedule, click **CANCEL**.

Repeat the steps above if multiple schedules are needed.

To edit an existing schedule:

1. Click the **pencil** icon from the line of the desired schedule to edit. An EDIT SCHEDULE pane opens on the right side.
2. Make the desired changes.
3. When finished, click **SAVE** to set the schedule. To close the window without saving the schedule, click **CANCEL**.

To delete an existing schedule:

1. Click the **trash can** icon from the line of the desired schedule to delete. A dialog opens to confirm the deletion of the schedule.
2. Click **DELETE** to delete the schedule. To close the window without deleting the schedule, click **CANCEL**.

ADD SCHEDULE

* Indicates required field

Schedule Name*

Display Control *

ON

OFF

Time*

Select days to apply schedule*

Monday

Tuesday

Wednesday

Thursday

Friday

Saturday

Sunday

Description

SAVE

CANCEL

Figure 29. Schedules Pane

Sensor Page

The Sensor page has five panels to view the status and configure the occupancy, motion, and acoustic sensor settings. Select the **Sensor** subtab (see [figure 21](#), ⑨ on page 26) under the **CONFIGURATION** tab to open the Sensor page (see figure 30).

NOTE: Extron has selected default values determined ideal settings for most typical applications. We recommend using the WC Pro 150 OCS in the default settings when beginning the setup and testing. If needed, make slight adjustments at a time from the default sensitivity settings.

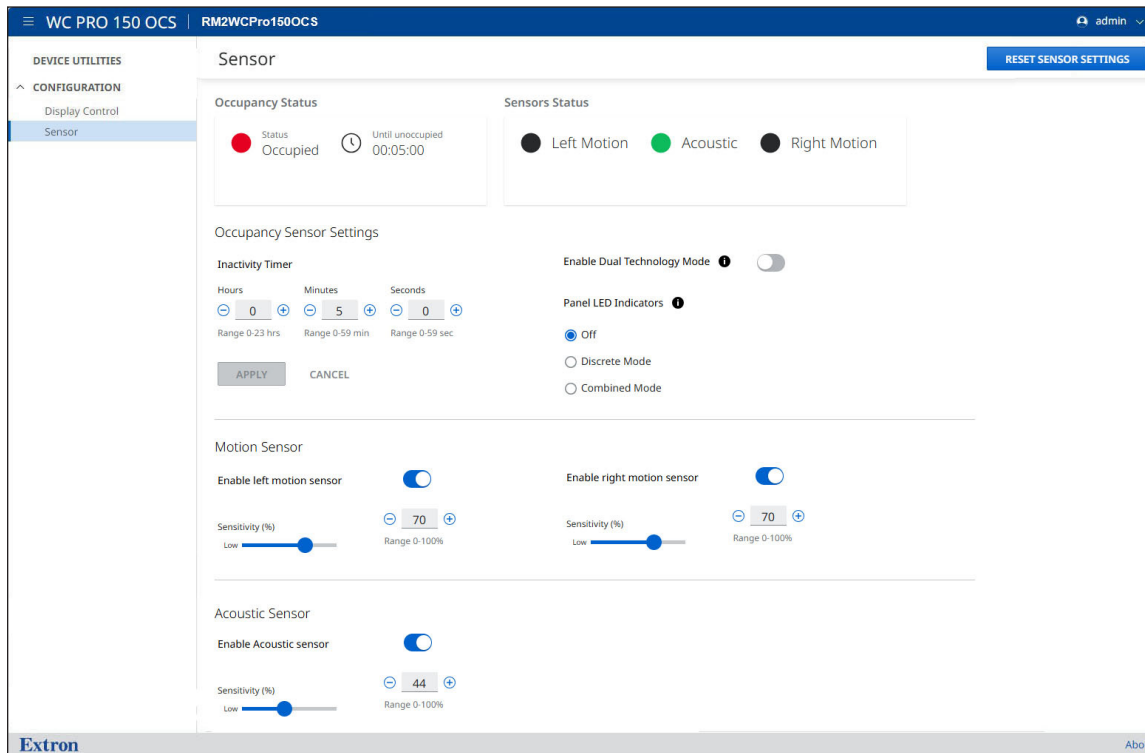

Figure 30. Sensor Page

Occupancy Status and Sensor Status panels

These two panels display the live status of the occupancy of the room and the status of the motion and acoustic sensors.

Note: The *Until unoccupied* countdown timer shown in the *Occupancy Status* panel visually shows that the inactivity timer is working. When the countdown elapses to 0:0:0, the status changes to *Unoccupied*. When a sensor detects activity the countdown timer resets to the time set in the inactivity timer.

Reset button

The **RESET SENSOR SETTINGS** button at the top of the page resets all the sensors to the default values.

Occupancy Sensor Settings panel

Configure the settings for the inactivity timer and dual technology mode in this panel.

Note: The only setting that is not immediate and requires the **Apply** or **Cancel** button is the *Inactivity Timer*. All other settings on this page take affect immediately.

Inactivity Timer

The inactivity timer indicates how long the device needs to wait, since the last time a sensor detects room occupancy, before changing the room status to Unoccupied.

To configure the inactivity timer:

1. Set the **Inactivity Timer** in hours, minutes and seconds (**default** is 5 minutes).
2. When finished, click **APPLY** to keep the settings. Click **CANCEL**, to not save the new inactivity timer setting.

Panel LED Indicators

The front panel LED indicators can be configured to operate in three modes.

To set the mode for the panel LED indicators:

Select a radio button for the desired mode:

- **OFF** — Disables the sensor activity LEDs on the device front panel (**default**). The sensor status LEDs in the Internal Web Page are always active.
- **Discrete Mode** — A separate LED is used for each of the sensors detection activity.
In discrete mode the left and right motion sensors each have a red LED that blinks and the acoustic sensor has a green LED in middle of the front panel that blinks for individual sensor detection activity.
- **Combined Mode** — A single green LED (middle) is used for any of the sensors detection activity.
In combined mode, only the middle green LED blinks for all sensor activity.

Enable Dual Technology Mode

If desired, toggle the **Enable Dual Technology Mode** switch to enable and disable this function (**default** is off). When enabled, the Dual Technology requires both a motion sensor and acoustic sensor detection be triggered to set the Occupancy Status as Occupied. This helps prevent false detection setting room status to occupied.

When the Dual Technology Mode is enabled the check marks show up on screen indicating live status of motion or acoustic detection. When no acoustic or motion has been detected for 1 minute, the check marks are black.

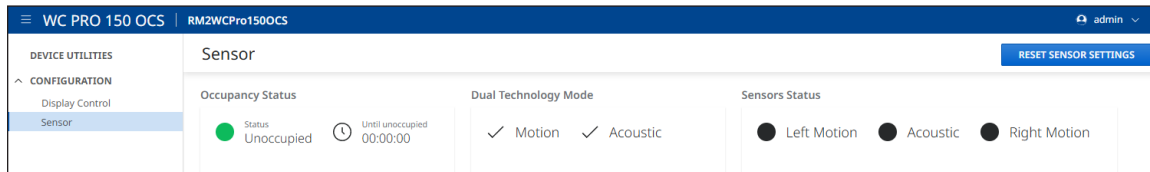

Figure 31. Dual Technology Mode Undetected

Once both motion and acoustic is detected, the check marks turn green and the room occupancy status changes to Occupied.

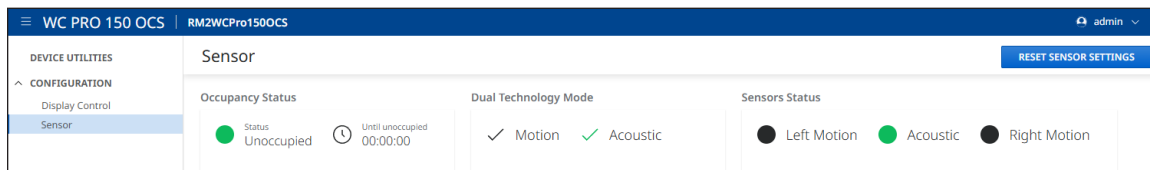

Figure 32. Dual Technology Mode with Single Sensor Type Detected

Motion Sensor panel

Configure the settings for the motion sensors in this panel. Each motion sensor can be configured individually.

NOTE: Low sensitivity makes it harder for a sensor to trigger, requiring larger motion or motion and activity closer to the sensor.

Higher sensitivity makes it easier for a sensor to trigger from smaller motions or at farther distances.

Larger rooms generally require higher sensitivity settings.

To configure the motion sensors:

1. Toggle the switches to enable or disable each of the left and right motion sensors. **Default** is enabled for both.
2. To set the sensor sensitivity from low to high for each sensor, slide the fader from left to right, use the - and + buttons to increase or decrease sensitivity, or enter a number from **0** to **100%**. **Default** is 70%.

Acoustic Sensor panel

Configure the settings for the acoustic sensor in this panel.

NOTE: Low sensitivity makes it harder for a sensor to trigger, requiring louder sounds at closer distances for detection. High sensitivity makes it easier for a sensor to trigger, requiring less sound at farther distances.

High sensitivity increases the chances of ambient sounds outside of the given space or room to cause the sensor to trigger.

To configure the acoustic sensor:

1. Toggle the switch to enable or disable the acoustic sensor. **Default** is disabled.
2. To set the sensor sensitivity from low to high for each sensor, slide the fader from left to right, use the - and + buttons to increase or decrease sensitivity, or enter a number from **0** to **100%**. **Default** is 44%.

About the WC Pro 150 OCS

Click on the **About** link (see [figure 21](#), [10](#) on page 26) to open the About dialog box to view general information about the WC Pro 150 OCS, such as the firmware version, copyright, part number, licenses, patents and web page version. Click on the **View the End User License Agreement** link to view the user license.

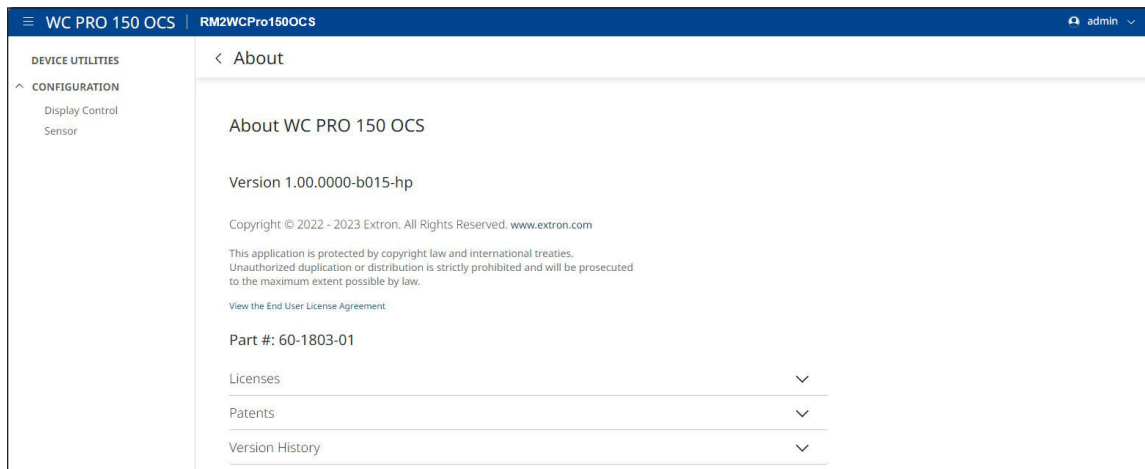

Figure 33. About the WC Pro 150 OCS Dialog Box

Advanced Software Configuration

This section of the guide is divided into the following topics:

- [Configuration and Control: an Overview](#)
- [Basic Setup Steps: a Guide to this Section and Other Resources](#)
- [Downloading the Software and Getting Started](#)
- [Using GC: Helpful Tips](#)
- [Troubleshooting](#)

Configuration and Control: an Overview

An WC Pro can be used out of the box, but can be reconfigured before use. For advanced configuration with Global Configurator Professional (GC Professional) or Global Configurator Plus (GC Plus) the LinkLicense for the WC Pro Control Processor is required. It can be configured and controlled via a host computer attached to the same network as the controller (see [Installation Step 4: Set up Network Communication](#) starting on page 17 for details about the LAN port and cabling to connect the controller to the network).

- Configure the controller by using the Global Configurator software in GC Professional or GC Plus mode (see the Extron [website](#) for full system hardware and software requirements for GC).
- If not using GC Professional or GC Plus, use ControlScript programming software to program the control system as desired.
- Using GlobalViewer, users can monitor the WC Pro.
- When the device has been configured with GCP configuration file, the default web pages embedded within the controller provide a means to view general hardware information, network settings, and, if configured, project information.

NOTE: See the diagram within [Control and power — LAN \(Ethernet\) and PoE](#) on page 8 for the default login credentials.

Basic Setup Steps: a Guide to this Section and Other Resources

NOTE: GC projects can be created offline and uploaded to the hardware at a later date.

Follow the steps in [Installation and Operation](#) starting on page 7. The overall process for setting up a controller using GC is as follows:

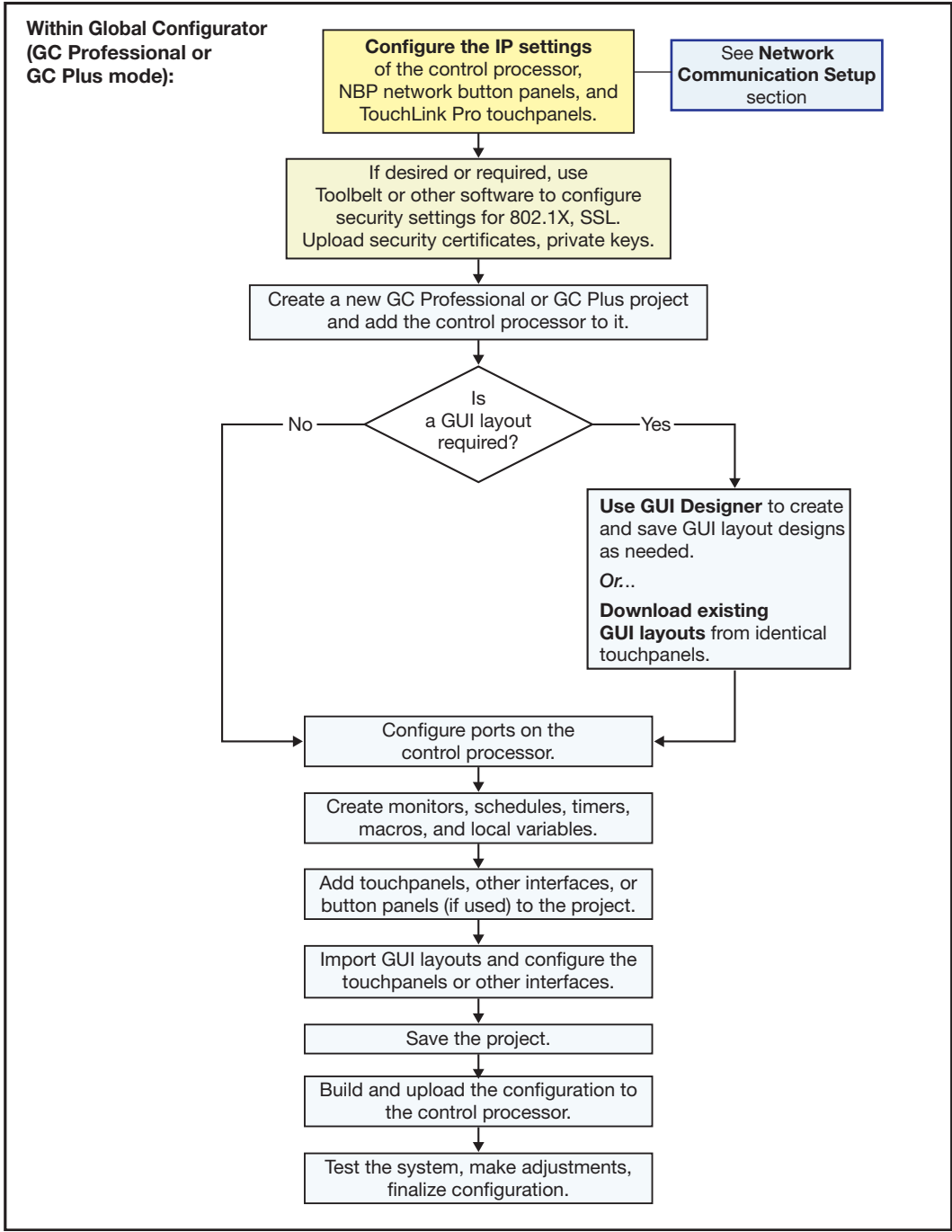

Figure 34. Overall Configuration Steps

Downloading the Software and Getting Started

GC software, software updates, and a large variety of device drivers can be downloaded from the Download page on the Extron website (www.extron.com/download/index.aspx). When the desired software or driver package is located, follow the on-screen directions to download and install it.

Locating Software, Firmware, and Driver Files on the Extron Website

There are three main ways to find software, firmware, and device drivers within www.extron.com:

- Via links from the web page for the specific product.
- Via the **Download** page (Click on the **Download** tab at the top of any page within the Extron website).
- Via links from search results

NOTE: For some software, there is an option to click the **Download** button to begin downloading the software file. For other software there is a link for contacting an Extron support representative who can provide access to the latest version.

To obtain Global Configurator (GC Professional, GC Plus) or ControlScript software, you must have an Extron Insider account and contact an Extron support representative. Extron provides training to our customers on how to use the software. For Global Configurator Professional, you must first attend Extron training, pass a proficiency test, and achieve Extron Control Professional Certification before being able to access all the features of that program.

Via links from the web page for the specific product

1. Navigate to the web page for the specific product model by performing one of the following:
 - Typing the model name into the **Search** field in the upper right of any Extron web page and clicking the **magnifying glass** icon

or

 - Selecting the model name from the **Product Shortcuts** drop-down list in the upper left of the Extron home page or Products page.
2. Click the **Downloads** tab in the middle of the product page. A list of available software, firmware, and documents for that model appears on screen.
3. Click on the name of the desired software or firmware to start downloading the file, or click on the link for device drivers to navigate to a page to select either a driver package or specific drivers for individual devices.

Via the Download Center page

1. Click on the **Download** tab at the top of any page within the Extron website to access the **Download** page.
2. Click on the link for the desired software product category (such as Global Configurator Professional software or control system device drivers) in the center of the screen. A page opens that allows you to make more specific selections from within that category.
3. For **software**, click on the link for the specific software needed. A software product page opens that provides a description of the software package, a list of system requirements, a list of features, and access to the release notes, in addition to a download link.

For GCP software drivers or drivers used in GCP software:

- a. Click on the **Control System Drivers** button.
- b. Select the name of the controller from the drop-down list.
- c. Click the link directly below the search fields to download the current Pro Series driver package of all available drivers supported by the control processor. Alternatively, search for, locate, and select the device or devices for which you need a driver file.
- d. To download a single driver rather than the package, click on the appropriate link in the row for the product desired to control to download the driver or to download the communication sheet. The communication sheet provides details helpful for working with the product and its control driver.

4. For some software, click the **Download** or **Download Now** button to begin downloading the software file. For other software there is a link for contacting an Extron support representative who can provide access to the latest version.

For **drivers**, navigate through the alphabetically arranged list to select and download a driver for a specific device.

Via links from search results

1. Type the specific name of the software package (such as **Global Configurator** or **GUI Designer**) into the **Search** field in the upper right of the page and click the **magnifying glass** icon. A search results page appears.
2. Click on the name of the software package. A software product page opens that provides a description of the software package, a list of system requirements, a list of features, and access to the release notes, in addition to a download link.
3. For some software, click the **Download** or **Download Now** button to begin downloading the software file. For other software, there may be a link for contacting an Extron support representative who can provide access to the latest version.

Obtaining Control Drivers

Extron provides an extensive selection of device drivers available on the Extron website. Ethernet, serial, CEC, and infrared (IR) device drivers (for controlling projectors, displays, DVD players, document cameras, and so forth) are available as individual device driver files. Prior to configuration, download driver files for products to be used in the installation (see [Installation Step 1: Get Ready](#) on page 7 to download software).

If the system requires a driver that is not already available, request a new serial (RS-232), IR, CEC, or Ethernet driver from Extron.

Things to Do After Installing GC and Before Starting a Project

- Read the *Global Configurator Help File* for details and step-by-step procedures on how to start a GC Professional or GC Plus project and perform basic setup tasks for a controller. The help file provides information on settings and how to use the software.
- Obtain network addresses and related information from your network administrator.
- Set up the IP address for the controller (see [Installation Step 4: Set up Network Communication](#) on page 17 for an overview of how to set up the network properties of the unit). For details, see the *Global Configurator Help File* or *Toolbelt Help File*. The help files contain instructions on how to set the IP address, gateway IP address, subnet mask, mail server IP address, domain name, web port, SMTP username, and SMTP password so that the controller is able to communicate with the network.

Using GC: Helpful Tips

Resources and Notes

- The *WC Pro 150 OCS Setup Guide* ships with the units. It includes a quick reference to the front and rear panel features, and covers basic hardware installation.
- See [Panel Features](#) on page 15 and [Port Expansion Interface Connections and Cabling](#) on page 8 in the [Installation and Operation](#) section of this guide for features and settings for the ports that need configuring.
- If the controller is configured at the installation site, Extron recommends downloading drivers for all the devices in the installation **before** going out to the site.
- The Global Configurator project file (*.gcpro or *.gcplus) contains configuration settings and it can be saved to a directory or folder for backup or for installation on another WC Pro 150 OCS sensor. Saving a configuration is recommended before performing a firmware upgrade.
- IP address, subnet mask, and gateway address are required during network setup of the controller.

- The unit name is any name (for example, Room250-WCPro or LectureHallCtrlWC) desired to use to label a specific WC Pro unit. The default is a combination of the product name and part of the hardware (MAC) address. This can be changed to your choice of alphanumeric characters and hyphens (-).
 - Spaces are not permitted within the name of a unit or at the start or the end of a name.
 - Underscores (_) are not permitted.
 - Valid characters are A-Z, a-z, 0-9, and - (hyphen).
 - The unit does not distinguish between upper and lower case letters.
 - The name cannot start with a number or a hyphen, and it cannot end with a hyphen.
 - Maximum name length is 63 characters.

Troubleshooting

Connections and Configuration

Turn on the input devices (DVD players, VCRs, PCs, and other sources), output devices (display screens, projectors), the controller, and the PC. If an input or output AV device cannot be remotely controlled (does not respond as expected), check the following:

Power connections

- Ensure all devices are plugged in.
- Make sure each device is receiving power. The WC Pro front panel lights if the controller is receiving power.

Data connections

1. Check the cabling connections (see [Installation Step 3: Cable All Devices](#) starting on page 8) and make adjustments as needed. The Link LEDs on the WC Pro and on the PC should be lit solid green if a network connection is detected. If these LEDs are not lit, either the cable is faulty or not plugged in, or the wrong type of cable is being used (see [Installation Step 4: Set up Network Communication](#) starting on page 17).
2. Try to ping the unit by entering the **default IP address ping 192.168.254.250** at the command prompt on a PC, **or use the IP or web address provided to you by your system administrator.**

If no response:

- Make sure the unit is using the appropriate subnet mask (check with your system administrator).
 - Make sure your PC and network do not have a software firewall program that might block the IP address of the WC Pro unit.
3. If contact is established with the unit, but the WC Pro web pages cannot be accessed by your browser program, verify (via an Internet network options or preferences menu) that your browser is configured for direct network connection and is not set up to use a proxy server.

Device control connections and configuration

- Verify ports are wired correctly on the WC Pro and, if applicable, on the controlled device.
- Ensure each IR emitter head is placed adjacent to or directly over the IR pickup window on the controlled device.
- Verify the appropriate drivers were used while creating the GC configuration file and that the correct commands and signal types (IR, RS-232, Ethernet) are associated with the appropriate ports on the WC Pro and on the other devices.
- For digital input connections, verify whether the application requires the +5 VDC pull-up resistor within the WC Pro for TTL circuits and use the software to check whether it is selected within the configuration.
- Verify input voltage at the digital input port does not exceed 24 VDC.

If you are still experiencing problems, call the Extron S3 Sales & Technical Support Hotline or the **Extron S3 Control Systems Support Hotline** (1.800.633.9877).

Reference Information

This section of the guide includes the following reference items:

- [UL Guidelines](#)
- [Best Practices for Cleaning Your Extron Products](#)
- [Network Port Requirements and Licensed Third-Party Software](#)
- [File Types: a Key to Extron-Specific File Names](#)
- [SNMP](#)
- [Activity Statistics](#)

Full product specifications are available via the WC Pro 150 OCS product pages at www.extron.com.

UL Guidelines

The following Underwriters Laboratories (UL) guidelines pertain to the WC Pro 150 OCS:

CAUTION:

- **Manufacturer recommended operating temperature** — 0-50°C
- **Purpose of Control** — Operating Control, Occupancy Sensor
- **Pollution Degree** — 2
- **Impulse Voltage** — 500V

Consignes UL

Les consignes UL (« Underwriters Laboratories ») suivantes concernent le WC Pro 150 OCS :

ATTENTION:

- **Température de fonctionnement recommandée par le fabricant** — 0-50°C
- **Objectifs de contrôle** — Contrôle opérationnel, détecteur de présence
- **Degré de pollution** — Niveau 2
- **Impulsion de tension** — 500 V

Best Practices for Cleaning Your Extron Products

There may be times when it becomes necessary to clean your Extron product. Plastic surfaces and cosmetic finishes can be damaged by long term exposure to chemicals. Therefore, Extron recommends the following guidelines when cleaning our products.

All Extron products can be safely cleaned with:

1. 70% concentration or higher Isopropyl Alcohol
2. Disinfectant cleaners that:
 - Are non-ammonium based (for example, contains no ammonium chloride)
 - Contain 2% or less sodium hypochlorite (for example, 2% bleach, 98% water)

It is important to follow these general guidelines when cleaning:

1. If possible, unplug the device.
2. Spray the cleaner on a lint-free cloth until the cloth is damp.
3. Do not spray the cleaner directly onto the product.
4. Gently clean the product surface using the cloth.

Your health and safety are our top priority. Keeping devices clean, especially those in high-traffic environments and high-use applications, is a crucial step in minimizing the spread of infections. Please contact us if you have any questions about the guidelines or if you have a question about cleaning the product.



Network Port Requirements and Licensed Third-Party Software

Network administrators may find it useful to know which ports, protocols, and services are used by the IP Link Pro control processors, TouchLink Pro Touchpanels, Global Configurator Plus and Professional software, Toolbelt, and Extron Control (for IP Link Pro control systems). A list of protocols used for inbound and outbound communication for each type of device or software is available in the *Pro Series Control Product Network Ports and Licenses Guide*, available at www.extron.com.

The control processors use various licensed third-party software packages during operation. To view details about third-party packages and associated licensing:

1. Click the **License Information** button in the internal web pages of the control processor. A License Information window opens.
2. To view a copy of a listed package license, in the License Information window, click the link in the License column for the relevant package. This opens a copy of the package license in a separate window. A list of licenses is also available in the *Pro Series Control Product Network Ports and Licenses Guide* at www.extron.com.

File Types: a Key to Extron-Specific File Names

The controller uses files with the following extensions:

- **.eff** — This is an Extron firmware update file (see [Firmware Updates](#) starting on page 47 for details on firmware updates).
- **.eir** — These are IR driver files containing infrared commands for both web configuration and GCP. There is a separate **.eir** file for each device the WC Pro 150 OCS controls via infrared communication. Via Global Configurator, these files can be imported and associated with an IR port on a controller.
- **.gcplus** — This is a Global Configurator Plus configuration file.
- **.gcpro** — This is a Global Configurator Professional configuration file.
- **.pkp** — This is a driver package file for GCP software only (Ethernet, serial, CEC).
- **.pkj** — This is a driver package file for web configuration (Ethernet, serial, CEC).

SNMP

Extron control products support Simple Network Management Protocol (SNMP). SNMP facilitates the exchange of basic network management information between network devices. It helps in monitoring of operations and factors such as packet usage, memory usage, remote password resets, and collection of error information. An information technology administrator can use common IT tools to monitor those factors, as well as look up device location and the name of the contact person for the device.

The SNMP controls within Toolbelt provide a way to enable or disable SNMP. It also allows you to specify related information such as the name of a contact person, the physical location of the unit, and a community name. The text that is specified in these fields is seen by the network community when the unit is queried.

Extron control products support the following security levels:

- Management Information Base 2 (MIB-II)
- SNMPv2c

Activity Statistics

WC Pro 150 OCS logs its sensor activity status and room occupancy status events (not head counts). These logs can be retrieved using the **Toolbelt** > **Logs** tab and saved as a text file. The *.txt file can be imported into tools like Microsoft Power BI or Excel to create statistics and analysis on room usage.

Firmware Updates

If the need arises, the WC Pro firmware can be replaced. This section covers the following firmware-related topics:

- [Determining the Firmware Version](#)
- [Updating the Firmware](#)

Determining the Firmware Version

There are several ways to check which version of firmware the controller is using:

- View the device information in the Toolbelt.
- View the general status information section of the WC Pro embedded web pages.
- View the GlobalViewer (GV) web pages (if the controller has already been configured and the GV web pages have been generated, built, and uploaded to the controller).

Before using any of those methods, connect the controller and the PC to the same network. For details see [Installation and Operation](#) starting on page 7, and [Advanced Software Configuration](#) starting on page 39.

Using Toolbelt

NOTE: Toolbelt can also be launched from GCP, using the [Toolbelt](#) link.

1. Open the Toolbelt software.
2. Either add the desired WC Pro manually or start device discovery and select the desired controller from the list of discovered devices.
3. Click **Manage** in the row for the desired controller and view the device information that opens in that section.

Using a Browser

The controller comes with a set of factory default embedded web pages. Also, after configuration, the GlobalViewer (GV) application could be installed in the unit, providing a different set of web pages (see the *Global Configurator Help File* for information on how to use that software and the resulting web pages). Either type of web page (factory default or GV) can be used to find the firmware version and part number of the unit.

1. Start a browser program.
2. Type the IP address of the WC Pro 150 OCS into the address field of the browser and log on to the internal web page or to the optional GlobalViewer web page stored in the WC Pro (see the *Global Configurator Help File* for details).
3. Look for the general device or status information section.

Updating the Firmware

Firmware upgrade tools require the PC and the controller to both be connected to an Ethernet network. The instructions for each method of updating the WC Pro 150 OCS firmware assume the appropriate software has been installed on your PC first.

NOTES:

- Save the existing configuration to a file (see the *Global Configurator Help* file for instructions) before replacing the firmware. If the file is saved, the configuration can be restored to the WC Pro later using GC, if needed.
- Check the Extron website for firmware-related documents, instructions, patch files, and new firmware files before loading new firmware into the controller. We recommend that you read the firmware release notes (available from www.extron.com) before beginning the firmware update.

Locating and Downloading the Firmware

1. Visit the Extron website to find the latest firmware file for the WC Pro. The easiest way to locate files is through the **Downloads** tab on the web page for the specific model.
2. Download the executable installer file (*.exe) from the website and run the installer program. The program automatically stores the firmware file on the PC in C:\Program Files (x86)\Extron\Firmware\WC Pro 150 OCS within a folder specific to that version.
3. Write down the firmware filename and location for later use. The filename ends in .eff such as 49-622-50-x.xx.xxxx-yyyy.eff where x.xx.xxxx is the version number.

NOTE: The firmware update file must have a filename extension of .eff. If the file does not have that extension, it does not work properly.

Installing Firmware

Firmware can be replaced by using one of the following:

- Global Configurator (using the link to Toolbelt)
- Toolbelt
- Internal Web Page (see [Firmware Panel](#) on page 31)

These methods allow you to browse to find and select the appropriate .eff file on your PC and then click an **Upload** button to initiate the firmware upload to the controller.

NOTE: Use Toolbelt to update multiple devices with the same firmware version simultaneously.

Allow at least a couple minutes for the firmware to finish uploading. At the end of the upload process, the unit partially reboots and loses its connection to the PC. To continue using Toolbelt, reconnect via Toolbelt after the firmware update.

Extron Warranty



This Limited Warranty does not apply if the fault has been caused by misuse, improper handling care, electrical or mechanical abuse, abnormal operating conditions or non-Extron authorized modification to the product. Extron Electronics makes no further warranties either expressed or implied with respect to the product and its quality, performance, merchantability, or fitness for any particular use. In no event will Extron Electronics be liable for direct, indirect, or consequential damages resulting from any defect in this product even if Extron Electronics has been advised of such damage. Please note that laws vary from state to state and country to country, and that some provisions of this warranty may not apply to you.

Powered Warranty

Extron warrants its powered products against defects in materials and workmanship for a period of three years from the date of invoice. In the event of malfunction during the warranty period, Extron will repair or replace a product to whatever extent it shall deem necessary to restore the product to proper operating condition.

Powered Warranty Exception

Everlast™ Power Supplies — Extron warrants Everlast power supplies against any defects in materials and workmanship for a period of seven years from the date of invoice. In the event of a malfunction during the warranty period, Extron will repair or replace the power supply to its original operating condition. Extron engineers will examine the returned product and determine whether the Everlast Power Supply Warranty or Powered Product Warranty applies.

Speakers — Extron warrants Flat Field®, SoundField®, SpeedMount®, Column Array, and System INTEGRATOR® speakers against any defects in materials and workmanship for a period of five years from the date of invoice.

Touchscreens — Extron warrants touchscreen display and overlay components against any defects in materials and workmanship for a period of one year from the date of invoice.

Annotator 300 — Extron warrants the Annotator 300 against any defects in materials and workmanship for a period of five years from the date of invoice.

Non-Powered Warranty Exception

Cable Cubby, Hideaway Surface Access Enclosures and Retractors — Extron warrants Cable Cubby cable access enclosures, HSA Hideaway Surface Access enclosures, and Retractor cable retraction modules for a period of three years from the date of invoice.

Active Cables and Active Adapters — Extron warrants active cables and active adapter cables for a period of three years from the date of invoice.

Cable Termination Tools and Dies — Extron warrants cable termination tools for a period of three years from the date of invoice, excluding the die.

Return Information

Units must be returned insured, with shipping charges prepaid. If not insured, you assume the risk of loss or damage during shipment. Returned units must include the serial number and a description of the problem, as well as the name of the person to contact in case there are any questions.

NOTE: To assure the highest level of service, a return authorization number must be obtained from Extron before products are returned for service. Products must be shipped to Extron, prepaid along with proof of purchase **only** after obtaining a Return Authorization (RA) number from the Extron Customer Support department.

Please contact Extron to receive an RA (Return Authorization) number:

USA: 714.491.1500 or 800.633.9876

Asia: 65.6383.4400

Europe: 31.33.453.4040 or 800.3987.6673

Japan: 81.3.3511.7655

Africa and Middle East: 971.4.299.1800