

VN-QUANTUM

IMAGE DISPLAY PROCESSOR



VNQUANTUM

|

USER GUIDE

VN-QUANTUM PROCESSOR USER GUIDE
Part No. I455GB issue 8 (6 August 2009)

Copyright © 2007 Electrosonic Ltd.
All rights reserved.

No part of this documentation may be reproduced or transmitted in any form or by any means, electronic or mechanical, including photocopying and recording, without the prior written permission of Electrosonic Ltd.

The information in this documentation is supplied without warranty of any kind, either directly or indirectly, and is subject to change without prior written notice. Electrosonic, its employees or appointed representatives will not be held responsible for any damages to software, hardware, or data, howsoever arising as a direct or indirect result of the product(s) mentioned herein.

Issued by:

Product Support,
Electrosonic Ltd.,
Hawley Mill,
Hawley Road,
Dartford,
Kent,
DA2 7SY,
United Kingdom.

Documentation written and designed by Andrew M. Bailey.

Printed in the United Kingdom.

IMPORTANT SAFETY MARKINGS

The following symbols are used on the throughout this User Guide to advise you of important instructions:



This symbol warns the presence of a voltage of sufficient magnitude to cause a severe or fatal electric shock. Follow the appropriate instructions carefully to avoid the risk of injury.



This symbol indicates an important instruction for the correct and safe installation, operation or maintenance of your VN-QUANTUM PROCESSOR system. Failure to comply with such instructions may result in injury to personnel or damage to the VN-QUANTUM PROCESSOR hardware.



This product conforms with the protection requirements of the EC Directive 89/336/EEC (relating to Electromagnetic Compatibility) and EC Directive 73/23/EEC (relating to Low Voltage) by application of the following standards:

EN 55103-1:1996; EN 55103-2:1996; EN60950:2000

Provided that:

- The product is used in accordance with the manufacturer's instructions.
- The product is not connected to any peripheral equipment that is not CE marked.



This product has been tested by Underwriters Laboratories Inc.[®] (file no. E163058) and found to be fully compliant with the following safety standards:

UL 60950-1:2003

Information Technology Equipment Safety - Part 1: General Requirements

CSA C22.2 No. 60950-1-03

Information Technology Equipment Safety - Part 1: General Requirements



This device complies with part 15 of the FCC Rules. Operation is subject to the following two conditions:

- (1) This device may not cause harmful interference, and
- (2) This device must accept any interference received, including interference that may cause undesired operation.

This page is intentionally left blank.

Contents

Contents	5
SECTION 1:	9
Installation & Setup	9
Unpacking Procedure.....	10
Checking the Supplied Components.....	11
ES3301-2 Check List.....	11
ES3302 & ES3304 Check List.....	12
Fitting the Power Supply Units (ES3301-2 only).....	13
ES3301-2 Installation Overview	14
ES3302 & ES3304 Installation Overview	15
Installing the Card Frame.....	16
Choosing a Suitable Location	16
Lifting and Moving the VN-QUANTUM Processor	16
Environmental Requirements.....	17
Orientation	17
Temperature	17
Ventilation	17
Humidity & Water.....	17
Rack-mount Requirements	18
Mounting & Support.....	18
Ventilation	18
Mains Supply	18
Connecting the Mains Supply.....	19
Supply Requirements.....	19
Mains Power Cord.....	20
Fitting a Mains Plug	21
<i>Wiring Details</i>	21
External Supply Protection	22
<i>Fused Plugs (UK-style)</i>	22
<i>Unfused Plugs or Hard-wired Installation</i>	22
Power-up Test (ES3301-2 only)	23
Connecting Sources.....	24
Video Sources	24
Input Channel Identification	24
Connection Example.....	25
RGB Graphics & HD Video Sources.....	26
Input Channel Identification	26
Connection Example.....	27
DVI Sources	28
Input Channel Identification	28
Connection Example.....	29
Connecting the Display.....	30
Output Channel Identification	30
Output Channel Mapping.....	30
Connection / Mapping Examples.....	31
Connecting to a Network	32
Network Settings.....	32
Connecting a Keyboard, Mouse & Monitor.....	33

Connection Example (ES3301-2 Card Frame)..... 34
 Connection Example (ES3302 & 3304 Card Frame) 35
 Changing Network Settings (using the VN-QUANTUM Control Panel) 36
Connecting the Control PC 37
 Control Port Settings..... 37
 Installing VN-COMMANDER Software..... 38
 Computer Specification 38
 Installation Procedure 38

SECTION 2: 39
Hardware Overview 39

Introduction 40
 Hardware Block Diagram (ES3301-2 Card Frame)..... 41
 Hardware Block Diagram (ES3302 & 3304 Card Frame)..... 42
15-slot Card Frame (ES3301-2) 43
 Front Panel Features..... 43
 Status Indicators..... 44
 Lower Access Panel & Latch..... 44
 Power On/Off Button 44
 O/S Reset Button 44
 Flash Drive..... 44
 Power Supply Units (PSU) 45
 Upper Access Panel..... 45
 Cooling Fans 45
 Internal Components 46
 CPU / Operating System 46
 PCI Bus..... 46
 RAPT Image Bus..... 46
 Rear Panel Features 47
 Mains Inlet Connector & Latch 47
 Network Ports..... 47
 Control Port..... 47
 Monitor Output..... 48
 PS/2 Ports..... 48
 USB Ports 48
8-slot Card Frame 49
 Front Panel (ES3302)..... 49
 Front Panel (ES3304 QUANTUM CONNECT) 50
 Front Panel Features..... 50
 Status Indicators..... 50
 Lower Access Panel & Latch..... 50
 Power On/Off Button 50
 O/S Reset Button 50
 Removable Hard Disk Drive..... 50
 Cooling Fans 51
 Internal Components 52
 CPU / Operating System 52
 PCI Bus..... 52
 RAPT Image Bus..... 52
 Rear Panel Features 53
 Mains Inlet Connector 53
 Network Ports..... 53
 Control Port..... 53
 Monitor Output..... 54
 PS/2 Port..... 54
 USB Ports 54
Input / Output Cards 55
 12-Channel Video Input Card (ES3311-2) 55
 2-Channel RGB Input Card (ES3312)..... 55

2-Channel DVI Input Card (ES3314).....	56
2-Channel Output Card (ES3310).....	56
Card Arrangement.....	57

SECTION 3: 58

Functional Overview 58

System Overview.....	59
External Sources.....	60
12-Channel Video Input Card (ES3311-2).....	60
Card Architecture.....	60
Auto-detection of Source Types.....	61
Timebase Correction (Frame Synchronization).....	61
Macrovision-encoded Sources.....	61
De-interlacing.....	62
Down-Scaling of Video Sources.....	62
Source Transfer.....	62
2-Channel RGB Input Card (ES3312).....	63
Card Architecture.....	63
Auto-detection of Source Types.....	63
Timebase Correction (Frame Synchronization).....	63
De-interlacing.....	64
Down-Scaling of RGB / HD Video Sources.....	64
Source Transfer.....	64
2-Channel DVI Input Card (ES3314).....	65
Card Architecture.....	65
Auto-detection of Source Types.....	65
Timebase Correction (Frame Synchronization).....	65
De-interlacing.....	66
Down-Scaling of DVI Video Sources.....	66
Source Transfer.....	66
Network Sources.....	67
VN-GLIMPSE RGB Graphics Sources.....	67
Source Transfer.....	67
Image Files.....	68
RAPT Image Bus.....	69
Guaranteed Real-Time Performance.....	69
RAPT Bandwidth Management.....	70
Target Display.....	71
ES3310 2-Channel Output Card.....	71
Card Architecture.....	71
Source Delivery.....	72
Source Palette.....	72
Up-Scaling.....	73
Output Channels.....	73
Understanding the Display Architecture.....	74
<i>Rectangulation Limit (RAPT Source Layer)</i>	74
Advanced Operating Principles.....	75
Source Scaling.....	75
De-interlacing.....	76
Input & Output Card Grouping.....	77
Control.....	78
VN-QUANTUM Control Panel.....	78
VN-COMMANDER (Quantum Edition).....	78
Remote Control.....	79
of VN-COMMANDER.....	79
of External Devices.....	79

Understanding the Capabilities of VN-QUANTUM	80
Overview	80
Example Scenarios	80
Scenario 1 – Maximum number of video sources on a single screen.....	81
Scenario 2 – Maximum number of Full Res video sources on a tiled display.....	82
Scenario 3 – Maximum number of video sources on a tiled display	83
Scenario 4 – Maximum number of video sources on the largest display	84
SECTION 4:	86
Maintenance	86
<hr/>	
Component Replacement Procedures	87
Removing and Replacing a PSU (ES3301-2 only)	87
Removing and Replacing a Cooling Fan	88
Cleaning the Ventilation Grilles & Filters.....	88
SECTION 5:	90
Technical Data.....	90
<hr/>	
ES3301-2 15-Slot Card Frame	91
Mechanical Data	91
Power Supply.....	91
Operating Environment.....	91
Conformance	91
Operating System	92
ES3302 & 3304 8-Slot Card Frame.....	93
Mechanical Data	93
Power Supply.....	93
Operating Environment.....	93
Conformance	93
Operating System.....	94
Control Inputs/Outputs	95
CONTROL Port.....	95
MEDIA I & II Ports (Not supported on the ES3304 VN-QUNATUM CONNECT).....	95
Keyboard/Mouse (PS/2 Port)	96
Monitor.....	96
USB Port	97
ES3310 Output Card.....	98
ES3311-2 Video Input Card	99
ES3311-CA Breakout Cable (for video input card)	100
ES3312 RGB Input Card	101
ES3314 DVI Input Card	102
APPENDIX A:.....	103
Guide to IP Addressing	103
<hr/>	
What is an IP Address?.....	104
Choosing IP Addresses.....	105
Subnet Mask.....	106
Using the 'Ping' Utility to Test Communications	107
Response Messages	107

SECTION 1:

Installation & Setup

Unpacking Procedure

The VN-QUANTUM Processor, together with various cables and accessories, is shipped in a sturdy wooden crate.

CAUTION: The crate is extremely heavy and two-person lifting is required.

To unpack the contents...

- Remove the eight screws (A) around the bottom edge of the crate.
- Using the lifting handles, carefully lift the top half of the crate up and away from the internal packaging and components.

HINT: You can also remove the eight screws around the top edge of the crate. This will allow the top panel to be removed, and the sides to be folded flat for easy storage. It is recommended that you retain the crate and all packaging for any future transportation.

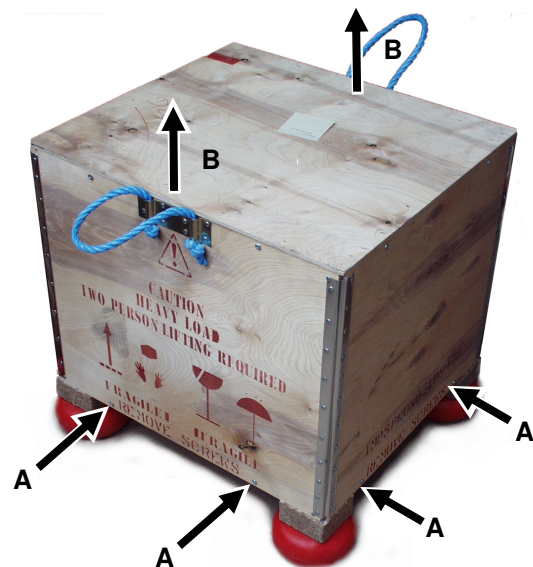

Checking the Supplied Components

Before installing or using the VN-QUANTUM processor please check that all of the following items have been supplied in the shipping crate and have not been damaged during transit

ES3301-2 Check List

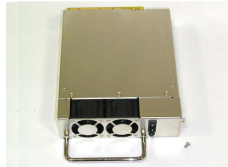

Power Supply Units (PSUs)

Two Card Frame PSUs are packed separately for transit and need to be installed into the Card Frame prior to use. See page 13 for installation details.



Mains Power Cords

Two IEC 320 (C14) mains power cards are supplied. One is terminated in a 3-pin 'Edison' plug (for USA) and the other is unterminated (for Europe and elsewhere). See page 19 for further details on connecting the mains supply.

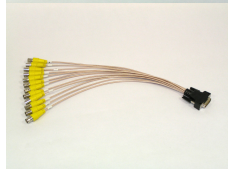

Input Card Breakout Cables

These are 26-pin D-type connectors with 12 coaxial flying leads, each approx. 400mm in length and terminated in an inline BNC connector. Check that you have two cables for each Input Card.



DVI-A to 15-pin VGA Adapters

These adapters are used to connect 15-pin VGA style connectors to the DVI output connectors. Check that you have two adapters for each Output Card.



Network Crossover Cable

A 5 metre (16ft) crossover patch cable, suitable for direct Ethernet connection between the VN-QUANTUM Card Frame and the VN-COMMANDER Control PC.



Keyboard and Mouse

A PS/2 compatible QWERTY keyboard and mouse used for low level setup of the VN-QUANTUM processor.



System Disc

A CD-ROM containing VN-QUANTUM software, including VN-COMMANDER, and User Documentation. Documentation is supplied in Adobe Acrobat (PDF) format.

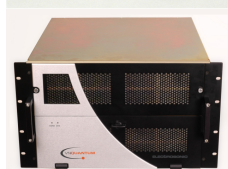

VN-QUANTUM Card Frame

With Input and Output Cards pre-installed to order. Compact Flash cards are also pre-installed.

ES3302 & ES3304 Check List



Mains Power Cords

Two IEC 320 (C14) mains power cards are supplied. One is terminated in a 3-pin 'Edison' plug (for USA) and the other is unterminated (for Europe and elsewhere). See page 19 for further details on connecting the mains supply.

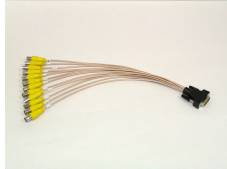

Input Card Breakout Cables

These are 26-pin D-type connectors with 12 coaxial flying leads, each approx. 400mm in length and terminated in an inline BNC connector. Check that you have two cables for each Input Card.



DVI-A to 15-pin VGA Adapters

These adapters are used to connect 15-pin VGA style connectors to the DVI output connectors. Check that you have two adapters for each Output Card.



Network Crossover Cable

A 5 metre (16ft) crossover patch cable, suitable for direct Ethernet connection between the VN-QUANTUM Card Frame and the VN-COMMANDER Control PC.



Keyboard and Mouse

A PS/2 compatible QWERTY keyboard and mouse used for low level setup of the VN-QUANTUM processor.

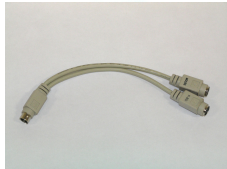

PS/2 Splitter Cable

A splitter cable for connecting both the keyboard and mouse to the VN-QUANTUM PS/2 port.



System Disc

A CD-ROM containing VN-QUANTUM software, including VN-COMMANDER, and User Documentation. Documentation is supplied in Adobe Acrobat (PDF) format.



VN-QUANTUM Card Frame

With Input and Output Cards pre-installed to order.

Fitting the Power Supply Units (ES3301-2 only)

- Open the lower front access panel of the Card Frame. (The panel is secured by a quarter-turn latch).
- Remove the retaining screw from the left-hand side of both PSU compartments.
- Insert a PSU fully into each compartment and secure with the retaining screw.

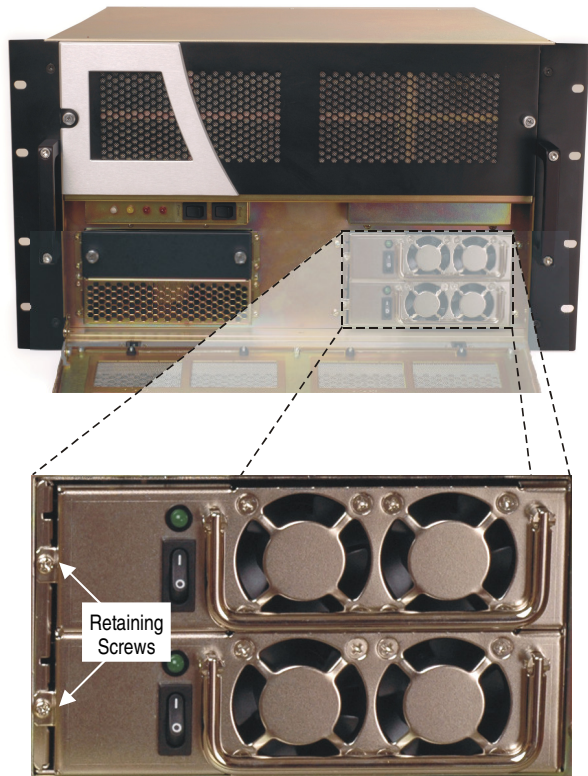

ES3301-2 Installation Overview

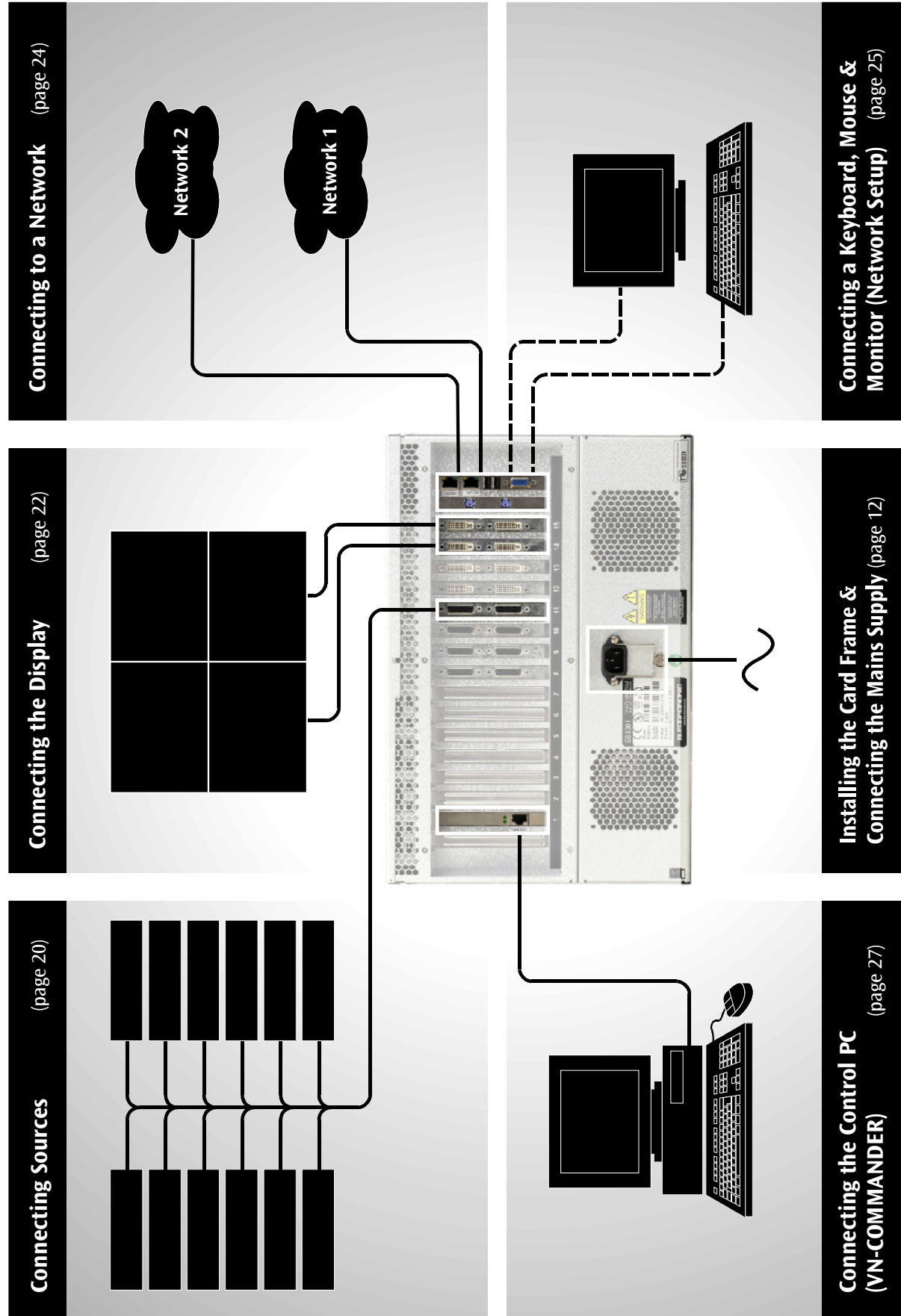

ES3302 & ES3304 Installation Overview

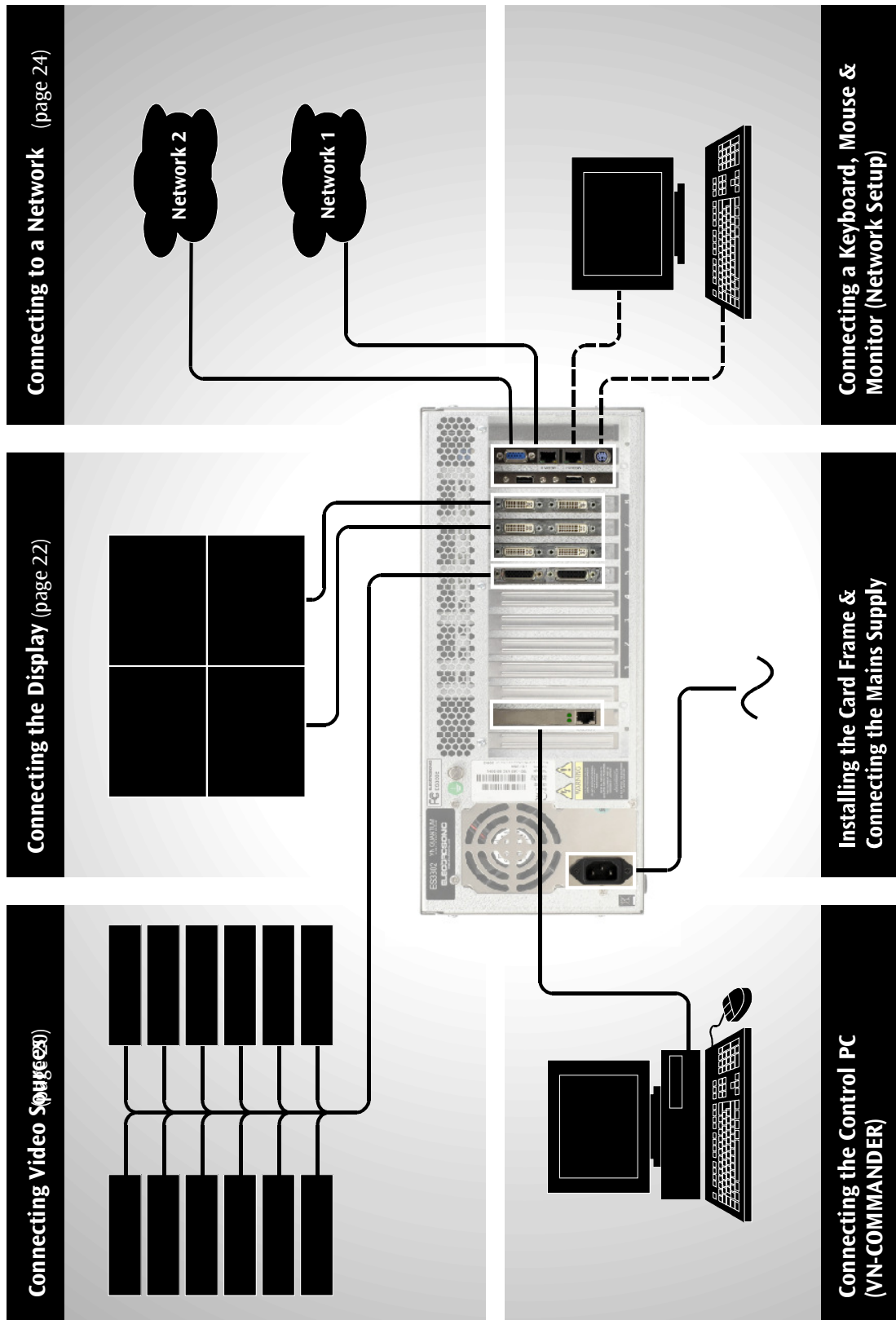

 Note: The ES3304 VN-QUANTUM CONNECT processor does not support the use of the Media ports (Network interface 1 & 2).

Installing the Card Frame

Choosing a Suitable Location

The VN-QUANTUM Processor is primarily designed to be mounted in a 19 inch equipment rack. However, it can be used as a freestanding unit if required.



CAUTION

However you decide to use the VN-QUANTUM Processor there are certain environmental requirements, detailed on page 17, which must be observed in order to ensure safe and reliable operation.

For rack-mounted applications the criteria detailed on page 18, must also be observed.

Lifting and Moving the VN-QUANTUM Processor

The VN-QUANTUM Processor is very heavy. When fully populated with input/output cards:

- The **ES3301-2** weighs up to up to **27.5kg / 61 lbs**
- The **ES3302** weighs up to up to **17.5kg / 38.6 lbs**

It is strongly recommended that you seek assistance when lifting or moving it.

Environmental Requirements



CAUTION

The criteria on this page must be observed for all VN-QUANTUM Processor installations, whether free-standing or rack-mounted.

Orientation

The VN-QUANTUM Processor must be operated in the horizontal position only. When used free-standing it must be placed on a stable, flat and level surface.

Temperature

DO NOT install or operate the VN-QUANTUM Processor in an area where the ambient temperature exceeds 35°C (95°F) or falls below 5°C (35°F).

Remember that, as with all electronic equipment, the VN-QUANTUM Processor also produces heat which will affect the ambient temperature.

Ventilation

DO NOT obstruct the front or rear ventilation grilles during operation as this will restrict the air flow and may cause the VN-QUANTUM Processor to overheat.

A ventilation gap of at least 100mm must be left between the front and rear panels of the VN-QUANTUM Processor and adjacent surfaces or equipment.

Humidity & Water

DO NOT install or operate the VN-QUANTUM Processor in an area in which the ambient relative humidity exceeds 85% or in an area that is prone to condensation.

DO NOT install or operate the VN-QUANTUM Processor near water or in a location which may be prone to water — the VN-QUANTUM Processor card frame is not waterproof.

WARNING: *To avoid the possible risk of electric shock or product damage due to condensation, ALWAYS allow the VN-QUANTUM Processor to become acclimatized to ambient temperature and humidity for at least thirty minutes BEFORE switching on. This is particularly important when moving the unit from a cold to a warm location.*

Rack-mount Requirements



CAUTION

For rack-mounted installations, the following criteria must be observed (in addition to the Environmental Requirements listed on page 17).

Mounting & Support

ALWAYS use additional support at the sides or rear of the VN-QUANTUM card frame. For example, by installing a suitable rack-mountable shelf beneath the unit, fixed to both the front and rear rack posts. Ensure that the shelf (or other mounting accessories) can support the full weight of the unit:

- The **ES3301-2** weighs up to **27.5kg / 61 lbs** (when fully populated)
- The **ES3302 & ES3304** weighs up to **17.5kg / 38.6 lbs** (when fully populated)

NEVER rely on the integral rack-mount brackets to support the full weight of the unit. These must only be used to secure the unit within the rack.

DO NOT stand other units directly on top of the VN-QUANTUM Processor when it is rack-mounted as this may overload the mountings.

Ventilation

ALWAYS ensure that the rack enclosure is adequately ventilated. Sufficient airflow must be achieved (by convection or forced-air cooling) to satisfy the ventilation requirements of **all** items of equipment installed within the rack.

A ventilation gap of at least 100mm must be left between the front and rear panels of the VN-QUANTUM Processor and adjacent surfaces or equipment.

No ventilation space is necessary above or below the VN-QUANTUM Processor.

Mains Supply

ALWAYS ensure that the mains power supply is of the correct voltage and frequency for **all** equipment within the rack, and that it has a good ground/earth connection.

Where a power strip (mains distribution batten) is used (of either a hard-wired or plug and socket type), always ensure that the current rating of both the power strip and the supply is sufficient for **all** equipment within the rack. Refer to the equipment rating plates or user documentation to establish power requirements.

Connecting the Mains Supply

Supply Requirements



ALWAYS observe the following instructions to ensure safe and reliable operation of the VN-QUANTUM Processor:

WARNING: THIS EQUIPMENT MUST BE GROUNDED / EARTHED.

NEVER connect the VN-QUANTUM Processor to a power point that does not have a ground or earth connection.

ALWAYS ensure that the mains supply voltage is single phase only and is within the permitted range:

110V / 230V AC (13A / 6 A Max.) 50 – 60Hz.

NEVER connect this product to a D.C. supply.

DO NOT allow the mains power point to be overloaded. This is particularly important to check when powering several items of equipment from a single power point (e.g. within rack-mounted installations). Refer to the equipment rating plates or user documentation to establish power requirements.

WARNING: *To avoid the possible risk of electric shock or product damage due to condensation, ALWAYS allow the VN-QUANTUM Processor to become acclimatized to ambient temperature and humidity for at least thirty minutes BEFORE switching on. This is particularly important when moving the unit from a cold to a warm location.*

IMPORTANT: *VN-QUANTUM features a 'soft' power switch. External power isolation must, therefore, be provided within easy reach of the unit. For example, mains connection must be via a switched power socket or power isolator located near to, and easily accessible from, the VN-QUANTUM card frame.*

Mains Power Cord

The VN-QUANTUM Processor is equipped with an IEC320 C14 3-pin (male) type mains connector which requires a power cord fitted with an IEC320 C13 (female) connector.

Two power cords are supplied with the VN-QUANTUM Processor, each having a different termination; you must use the lead appropriate for the country of installation:

In...	Use the...	Re-order Code
USA and Canada	cord fitted with the 3-pin American-style 'Edison' plug.	CA4292
UK, Europe and all other countries	unterminated cord and fit a suitable plug as described on page 21.	CA429

WARNING: Do not allow anything to rest on the mains power cord.

Fitting a Mains Plug

If you are fitting a plug to the unterminated power cord (or replacing an existing plug), the plug **MUST**:

- be rated for use with mains voltage
- be equipped with a grounding pin/connection
- comply with any applicable National or Local electrical regulations.
- be fitted with a correctly rated fuse (applicable to UK-style plugs only – see page 22.)

WARNING: Never attempt to fit or use a plug without a grounding or earthing pin/connection.

Wiring Details

The wires of both mains power cords (supplied with each VN-QUANTUM Processor) are color-coded as shown in the table below; be sure to connect your plug in accordance with the following guidelines:

Connect the wire colored...	to the plug terminal identified with...
Brown	'L' or 'Live' or 'Line' (or colored red or brown)
Blue	'N' or 'Neutral' (or colored blue or black)
Green & Yellow	'⏏' or 'E' or 'Earth' or 'Ground' (or colored green or green & yellow)
	WARNING — If you are unsure of the connections, or if the markings in your plug do not match those given above, CONSULT A QUALIFIED ELECTRICIAN.

WARNING: THIS EQUIPMENT MUST BE GROUNDED / EARTHED.

External Supply Protection



The mains power cord must be protected from overload by an external fuse or circuit breaker.

Fused Plugs (UK-style)

If the power cord is fitted with a UK-style BS1363 3-pin plug (*i.e.* with provision for an internal fuse), then it must be fitted with a BS1362 ASTA approved 1 inch cartridge fuse rated at 10A/250V.

Unfused Plugs or Hard-wired Installation

If the power cord is fitted with an unfused plug, or is hard-wired into a power strip (mains distribution batten), then the power cord must be protected by an external fuse or circuit breaker of a rating shown in the table below:

Supply Voltage	110V nominal	230V nominal
Fuse Rating	13A	10A
WARNING: Never attempt to fit a fuse or circuit breaker of a higher rating.		

Power-up Test (ES3301-2 only)

- ☞ Ensure that the Card Frame is connected to the mains supply.
- ☞ Ensure that all ventilation grilles are free from obstruction.
- ☞ Open the lower front access panel (secured by a quarter-turn latch).
- ☞ Move both PSU switches to the ON (1) position.
- ☞ Move the main **POWER** switch to the ON (1) position.
- ☞ Check for the following:
 - The main **POWER** indicator lights **green**.
 - Both PSU indicators light **green**.
 - All cooling fans are running.
- ☞ Briefly turn OFF (0) one of the PSU switches and check that:
 - An alarm sounds;
 - The main **POWER** indicator lights **red**.
- ☞ Turn the PSU back ON again and check that:
 - The alarm stops;
 - The main **POWER** indicator lights **green**.
- ☞ Close the lower front access panel and secure with the latch.

Connecting Sources

Video Sources

Analog video sources are connected to the Card Frame via one or more ES3311-2 Input Cards. Each card can accept up to 12 composite (CVBS) or S-Video (YC) sources, and inputs are made via two multi-way connectors at the rear of each card:

- The upper connector is for composite or S-Video luma (Y);
- The lower connector is for S-Video chroma (C) only.

Breakout cables are supplied which split the multiway connector into 12 inline BNC sockets. Each flying lead of the Breakout Cable is numbered from 1 to 12, corresponding to the 12 inputs.

Input Channel Identification

The VN-COMMANDER control software identifies each source by the slot number of the Input Card and the card input number. For example, sources connected to a card in slot 6 will be identified as 6.1, 6.2, 6.3 and so on up to 6.12.

Connection Example

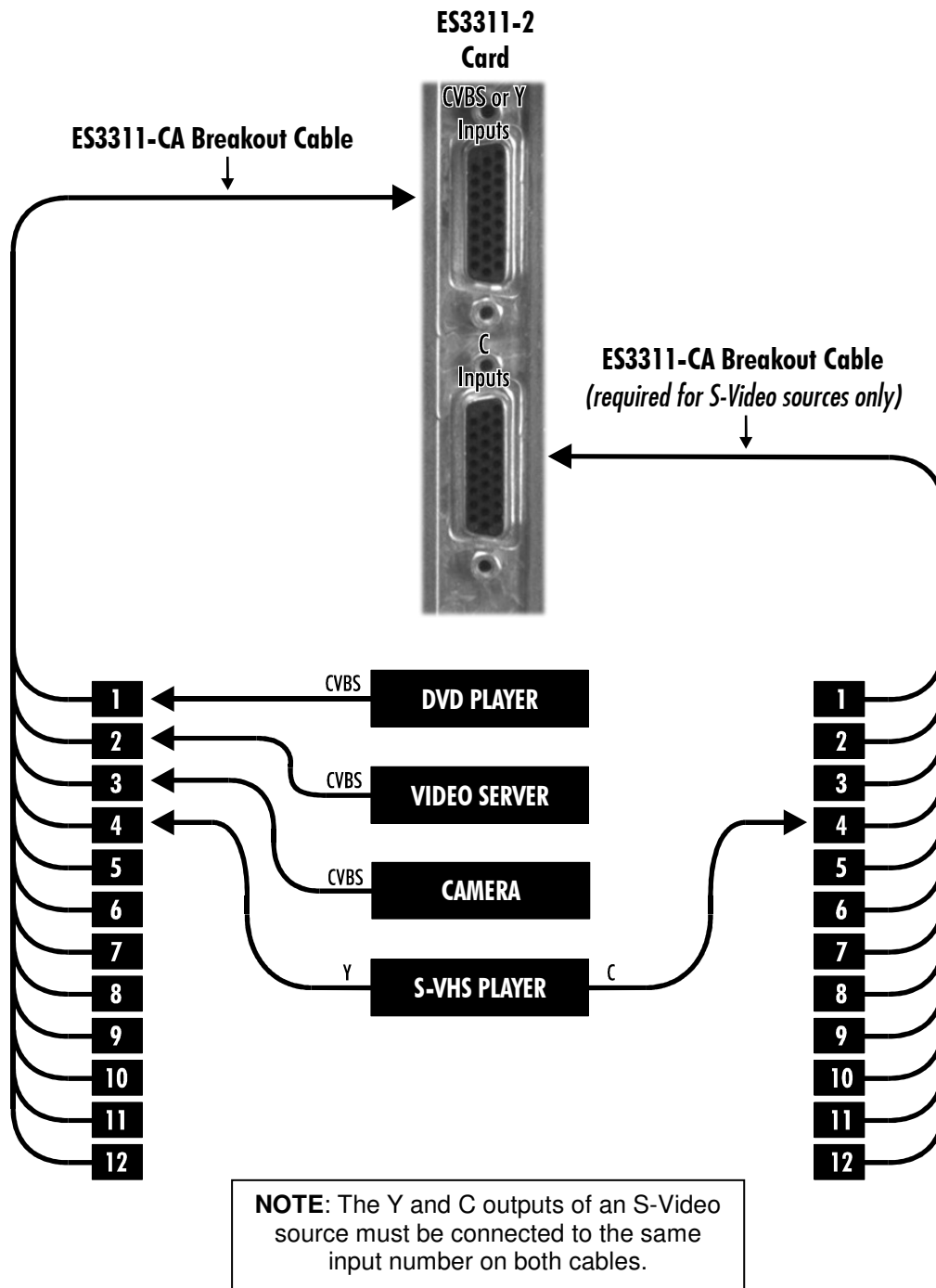

RGB Graphics & HD Video Sources

Analog RGB graphics sources or HD Video sources (in RGB or component YPrPb format) are connected to the Card Frame via one or more ES3312 RGB Input Cards. Each ES3312 card can accept 1 or 2 sources, and inputs are made via two standard 15-pin VGA type connectors at the rear of each card:

- The upper connector is for Input 1;
- The lower connector is for Input 2.

HINT: *Analog RGB graphics sources can also be delivered to VN-QUANTUM over an IP network connection, by using VN-GLIMPSE. See page 67 for further details.*

Input Channel Identification

The VN-COMMANDER control software identifies each source by the slot number of the Input Card and the card input number. For example, sources connected to a card in slot 5 will be identified as 5.1 and 5.2.

Connection Example

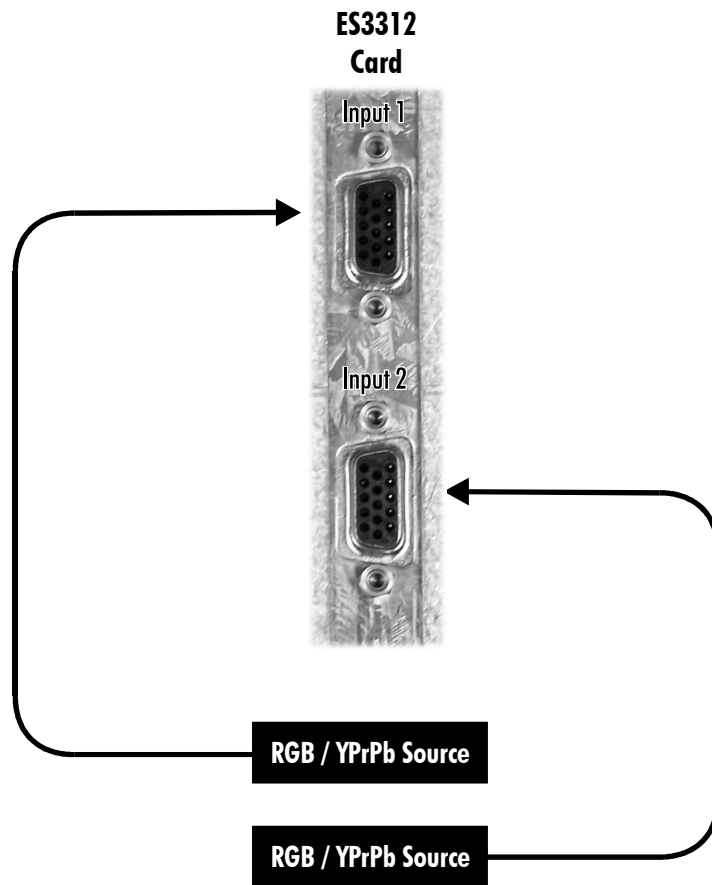

DVI Sources

Digital video or graphics sources are connected to the Card Frame via one or more ES3314 DVI Input Cards. Each ES3314 card can accept 1 or 2 sources, and inputs are made via two standard DVI-D type connectors at the rear of each card:

- The upper connector is for Input 1;
- The lower connector is for Input 2.

Input Channel Identification

The VN-COMMANDER control software identifies each source by the slot number of the Input Card and the card input number. For example, sources connected to a card in slot 5 will be identified as 5.1 and 5.2.

Connection Example

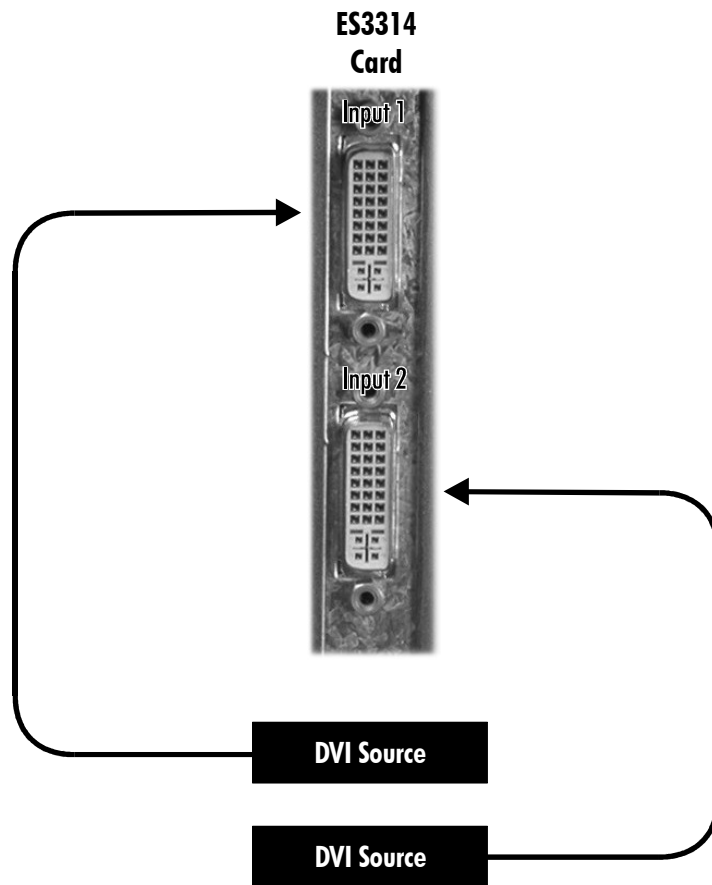

Connecting the Display

Display devices are connected to the Card Frame via one or more ES3310 Output Cards. Each ES3310 card has two output channels and these are accessed via two DVI-I connectors at the rear of each card:

- The upper connector is for output channel 1;
- The lower connector is for output channel 2.

The outputs can be configured (using VN-COMMANDER) to drive either analog or digital devices and at a variety of resolutions.

When connecting an analog display, you can either use a DVI-A type connector/cable, or use the DVI-VGA adapter supplied to allow connection of a conventional 15-pin style VGA cable.

Output Channel Identification

The VN-COMMANDER control software identifies each output channel by the slot number of the Output Card and the card channel number.

For example, if you have two Output Cards in slots 7 and 8, the output channels will be identified as 7.1, 7.2, 8.1 and 8.2.

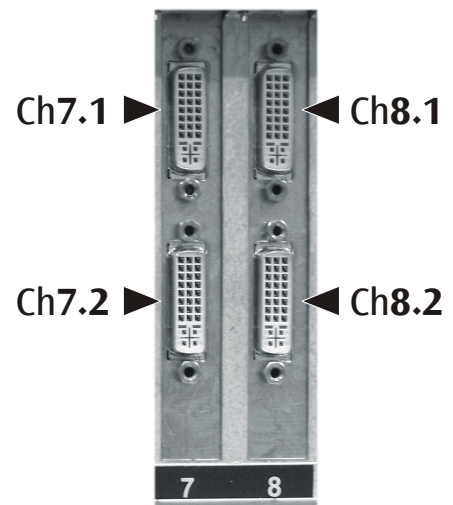

Output Channel Mapping

When connecting multi-screen displays, you need to consider the order in which screens are connected to the various output channels.

You can use VN-COMMANDER to map any Output Card to any location on the target display. However, there are three ways to use the output channels of each card and the method you choose will govern how you connect each screen:

- **Dual channel horizontal;** the channels are used to drive two screens placed side by side
- **Dual channel vertical;** the channels are used to drive two screens placed one above the other
- **Single channel;** only channel 1 is used and channel 2 is left unconnected. This method is used when the maximum number of windows need to be displayed on a single screen, or if there are an odd number of screens in the display.

You should choose whichever method (or combination of methods) best suits the layout of the target display, using the examples on the next page as a guide.

Refer to the VN-COMMANDER (Quantum Edition) User Guide for details of how to map the outputs to your target display.

Connection / Mapping Examples

All of the following display layout examples show channel numbering as seen from the normal viewing position. The first digit is the slot number of the card and the second is the output number. Note that the actual slot numbers may vary between systems, but the general recommendation is to start with the lowest numbered card slot in the top left corner.

ES3301-2 Card Frame

Dual Channel Vertical Configurations

14.1	15.1	13.1	14.1	15.1
14.2	15.2	13.2	14.2	15.2

Dual Channel Horizontal Configurations

15.1	15.2	10.1	10.2	11.1	11.2
14.1	14.2	12.1	12.2	13.1	13.2
15.1	15.2	14.1	14.2	15.1	15.2

Single Channel Configurations

14.1	15.1	12.1	13.1
		14.1	15.1

Mixed Configurations

11.1	12.1	13.1	11.1	11.2	12.1
11.2	12.2	13.2	13.1	15.1	12.2
14.1	14.2	15.1	13.2	14.1	14.2

ES3302 & 3304 Card Frame

Dual Channel Vertical Configurations

7.1	8.1	6.1	7.1	8.1
7.2	8.2	6.2	7.2	8.2

Dual Channel Horizontal Configurations

8.1	8.2	3.1	3.2	4.1	4.2
7.1	7.2	5.1	5.2	6.1	6.2
8.1	8.2	7.1	7.2	8.1	8.2

Single Channel Configurations

7.1	8.1	4.1	5.1
		6.1	7.1

Mixed Configurations

4.1	5.1	6.1	4.1	4.2	5.1
4.2	5.2	6.2	6.1	8.1	5.2
7.1	7.2	8.1	6.2	7.1	7.2

Connecting to a Network

The VN-QUANTUM Card Frame has two separate network ports – MEDIA I and MEDIA II. These allow connection to external Ethernet Local Area Networks (LAN) or Wide Area Networks (WAN) in order to access remote VN-GLIMPSE RGB sources or network-based files/media.

If your system does not use VN-GLIMPSE sources or network-based content, these ports can be left unconnected. Otherwise, you can use either or both ports as required.

Connection between the port(s) and the local network node must be made using a suitable CAT5 STP patch cable (not supplied).

Network Settings

The VN-QUANTUM is shipped with both ports set to DHCP (Dynamic Host Control Protocol), *i.e.* an IP Address is automatically assigned by the network.

If the network does not support DHCP you will need to configure the port(s) for fixed IP communications. Network settings can be changed by connecting a keyboard, mouse and monitor to the Card Frame. See pages 33 & 36 for further details.

Connecting a Keyboard, Mouse & Monitor

It is only necessary to connect a keyboard, mouse and monitor to the VN-QUANTUM if you need to perform one of the following operations:

- Change Network Settings
- Return to Default System Settings
- Access Service Mode
- Install New Software

VN-QUANTUM only supports PS/2-compatible mice and keyboards. A suitable PS/2 mouse and keyboard is supplied, together with a splitter cable.

The monitor output is suitable for analog monitors only. A monitor is not provided.

Connection Example (ES3301-2 Card Frame)

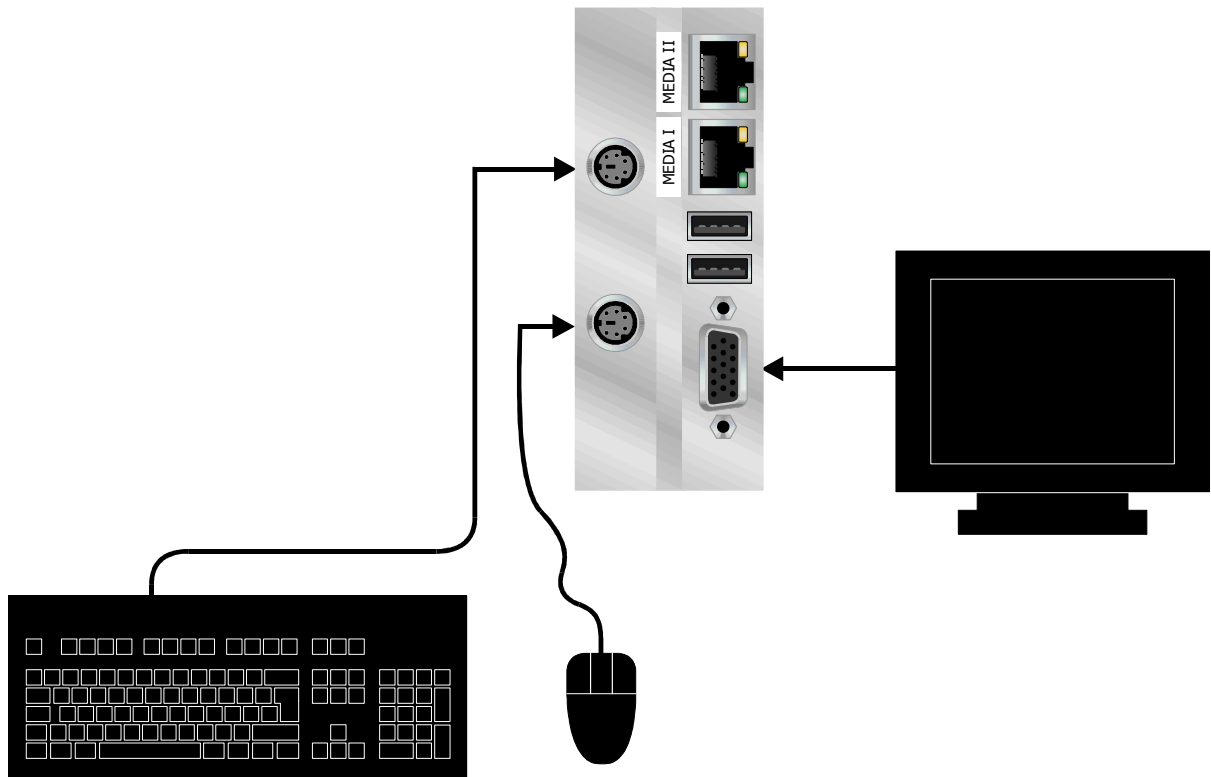

Connection Example (ES3302 & 3304 Card Frame)

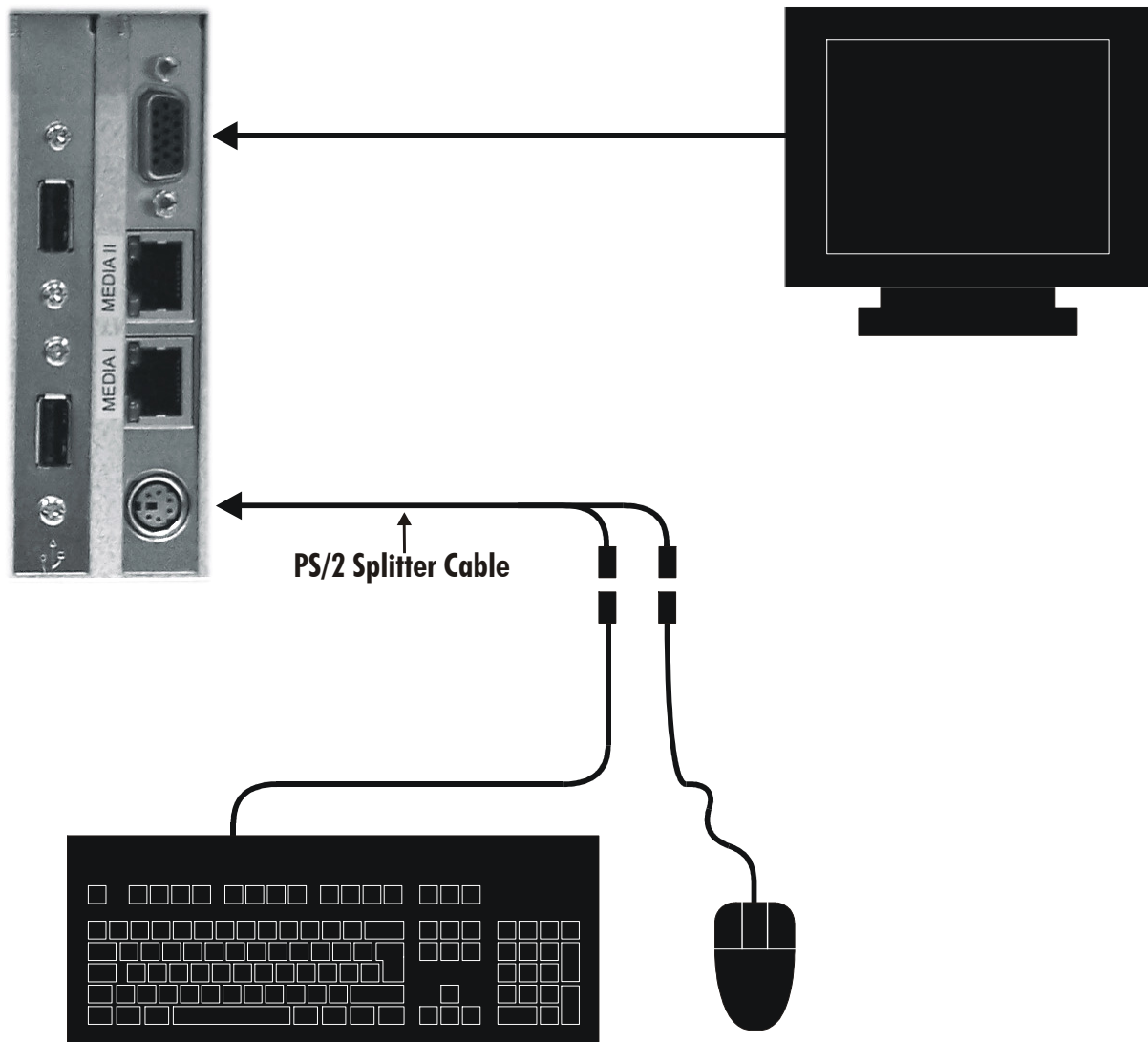

Changing Network Settings (using the VN-QUANTUM Control Panel)

- Ensure that the VN-QUANTUM is powered down.
- Connect a keyboard, mouse and monitor to the VN-QUANTUM Card Frame (see page 33)
- Power-up the VN-QUANTUM processor and wait for the VN-QUANTUM logo to appear on the monitor (this will take up to 90 seconds).
- Press the **Ctrl** and **F2** keys simultaneously to display the VN-QUANTUM Control Panel:

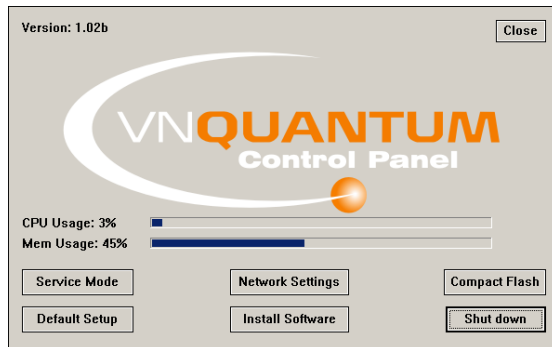

- Click on **Network Settings** to display the following dialog:

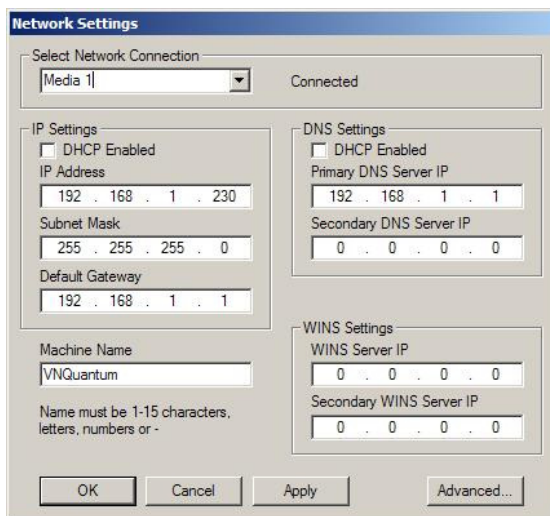

ES3301-2

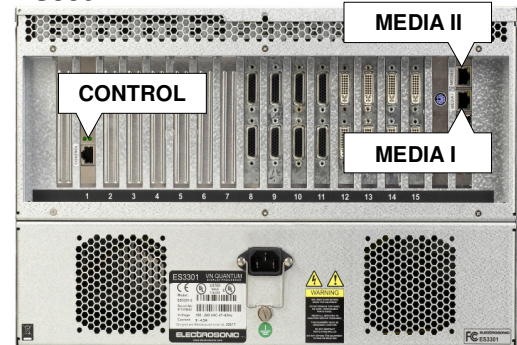

ES3302

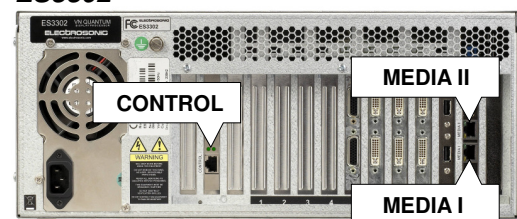

- In the **Network Connection** area, choose the port that you want to change:
 - **Control** (CONTROL connector)
 - **Media 1** (MEDIA I connector)
 - **Media 2** (MEDIA II connector)
- Change the **Network Settings** as required then click **Apply** or **OK**.

The new settings will only take effect once the processor has been rebooted.

A message will appear asking you if you want to reboot now.

- Click **Yes** to reboot now or **No** to reboot later.

	<p>Note that the VN-QUANTUM CONNECT processor does not support the use of the MEDIA I and II ports.</p>
---	---

Connecting the Control PC

VN-QUANTUM has a dedicated CONTROL port for the connection of a PC or laptop, running VN-COMMANDER application software.

Connection between the CONTROL port and the PC or laptop must be made using a CAT5 crossover patch cable (a 5m/16ft cable is supplied).

Control Port Settings

The VN-QUANTUM is shipped with the CONTROL port set to the following:

IP Address	172.28.232.11
Subnet Mask	255.255.000.000
Default Gateway	0.0.0.0
DNS Server	0.0.0.0
WINS Server	0.0.0.0
Name	VNQuantum

NOTE: The CONTROL port does not support DHCP operation.

To enable communications between the computer and VN-QUANTUM you must ensure that the IP Address and Subnet Mask settings are compatible on both devices:

- The **Subnet Mask** for both devices must be the same.
- The IP Address must be different, but in the same class/subnet.

To change the settings the VN-QUANTUM CONTROL port, follow the procedure on page 36.

For further help on IP Addressing, see Appendix A.

Installing VN-COMMANDER Software

IMPORTANT NOTE: VN-QUANTUM requires **VN-COMMANDER v1.4** software. No other version of VN-COMMANDER or CT-COMMANDER will work with VN-QUANTUM.

The VN-QUANTUM CONNECT processor requires **VN-COMMANDER CONNECT** control software. No other version of VN-COMMANDER will work with the VN-QUANTUM CONNECT processor.

Computer Specification

The VN-COMMANDER application software must be installed on a computer that meets or exceeds the following specification:

	Minimum	Recommended
Operating System	Windows NT4 (SP6)	Windows 2000, XP
Processor Speed	200MHz	450MHz or higher
Memory (RAM)	64MB	128MB or higher
Hard Disk Free Space	30MB	>30MB
Graphics	1024x768, 65K colors (16-bit)	1024x768, 16.7M colors (32-bit)
Network Card (Ethernet)	10BASE-T	100BASE-T

Installation Procedure

The VN-COMMANDER application software is provided on the VN-QUANTUM System Disc.

- ☞ Insert the VN-QUANTUM System Disc into a CD-ROM drive on the computer. After a few seconds the disc browser should start automatically.

HINT: *If the disc browser does not start for any reason, start it manually by running the setup.exe file located on the root of the disc.*

- ☞ Click on the Install VN-COMMANDER option then follow the on-screen instructions.

SECTION 2:

Hardware Overview

Introduction

This section contains a general description of the VN-QUANTUM hardware and concentrates on giving details of the various hardware components and the location of key physical features. For an overview of VN-QUANTUM functionality, refer to Section 3.

	<p>Note: The ES3304 VN-QUANTUM CONNECT processor has the same architecture as the ES3302 VN-QUANTUM processor.</p> <p>Note that the VN-QUANTUM CONNECT has a reduced feature set when compared to the ES3302 processor:</p> <ul style="list-style-type: none"> - No support for GLIMPSE source types. - No support for picture & image file source types. - No support for window borders or window text. - No support for Clock and timer source types. - No support for multiple processor systems. - No support for overlapped or over-scanned displays. - No support for screen capture.
---	---

The VN-QUANTUM is a fully modular system, allowing each unit to be individually configured to best suit the requirements of the end user application. The hardware comprises a Card Frame into which is installed a number of Input and Output Cards. The cards, all operating system software and drivers are pre-installed to order enabling quick and easy installation on site.

The following diagrams show the main hardware components of the VN-QUANTUM Processor:

Hardware Block Diagram (ES3301-2 Card Frame)

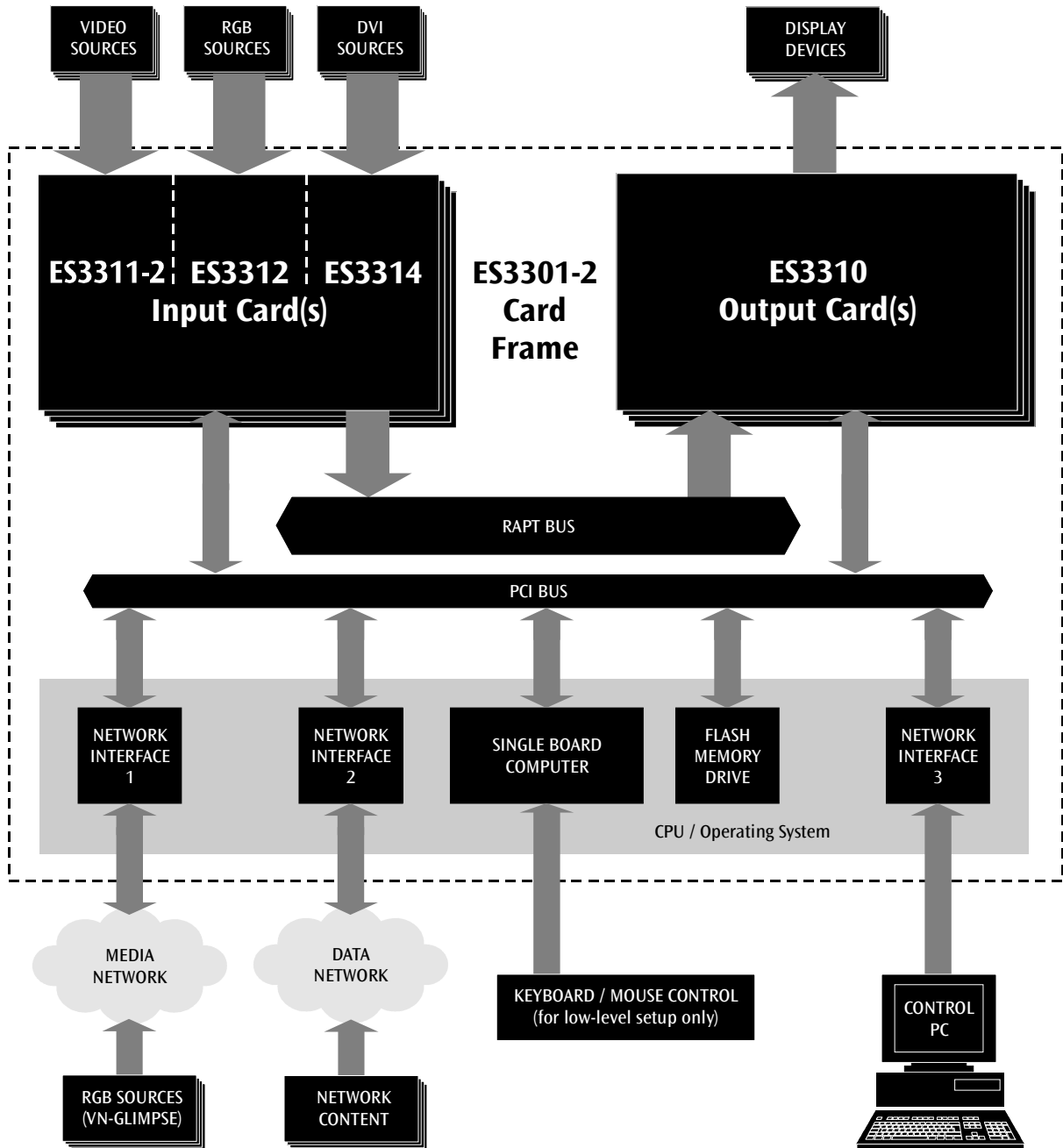

Hardware Block Diagram (ES3302 & 3304 Card Frame)

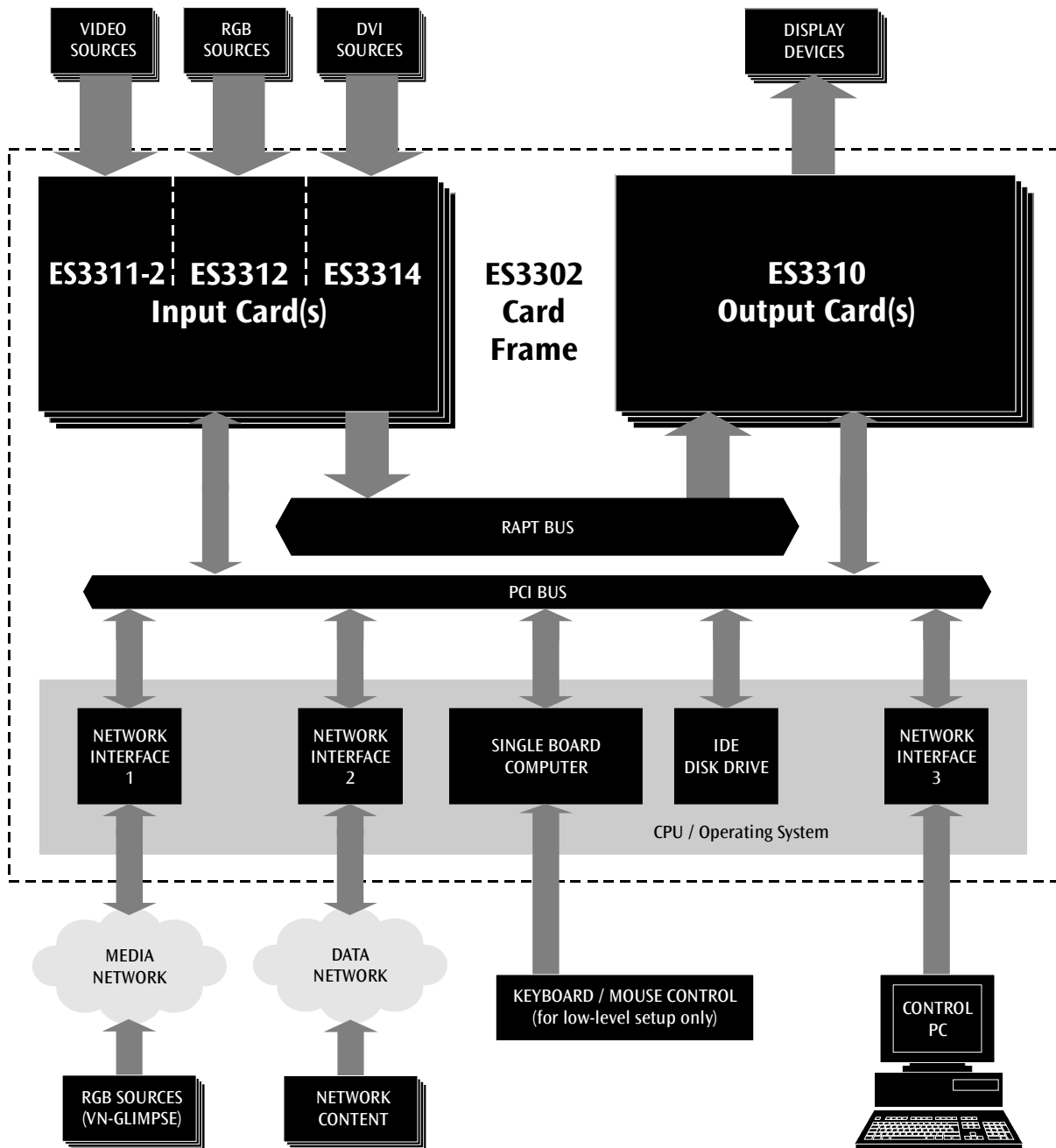

 Note: The ES3304 VN-QUANTUM CONNECT processor does not support the use of the Media ports (Network interface 1 & 2).

15-slot Card Frame (ES3301-2)

Front Panel Features

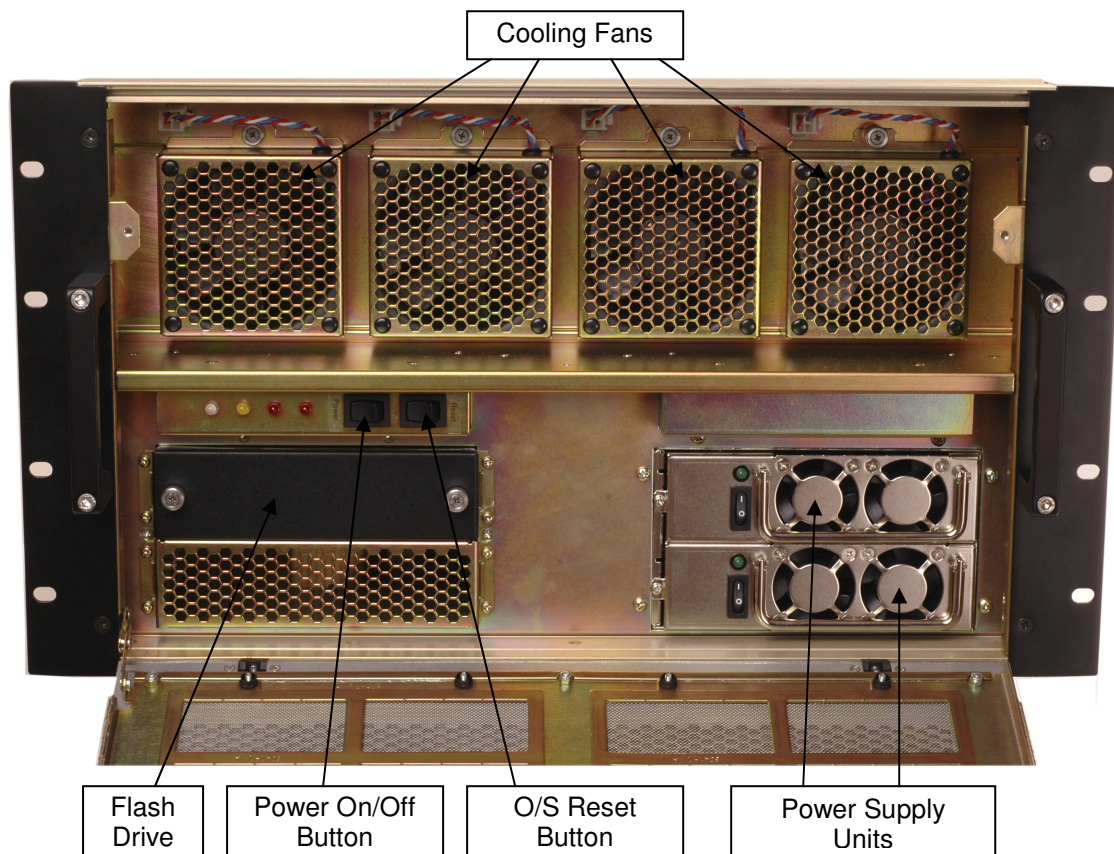
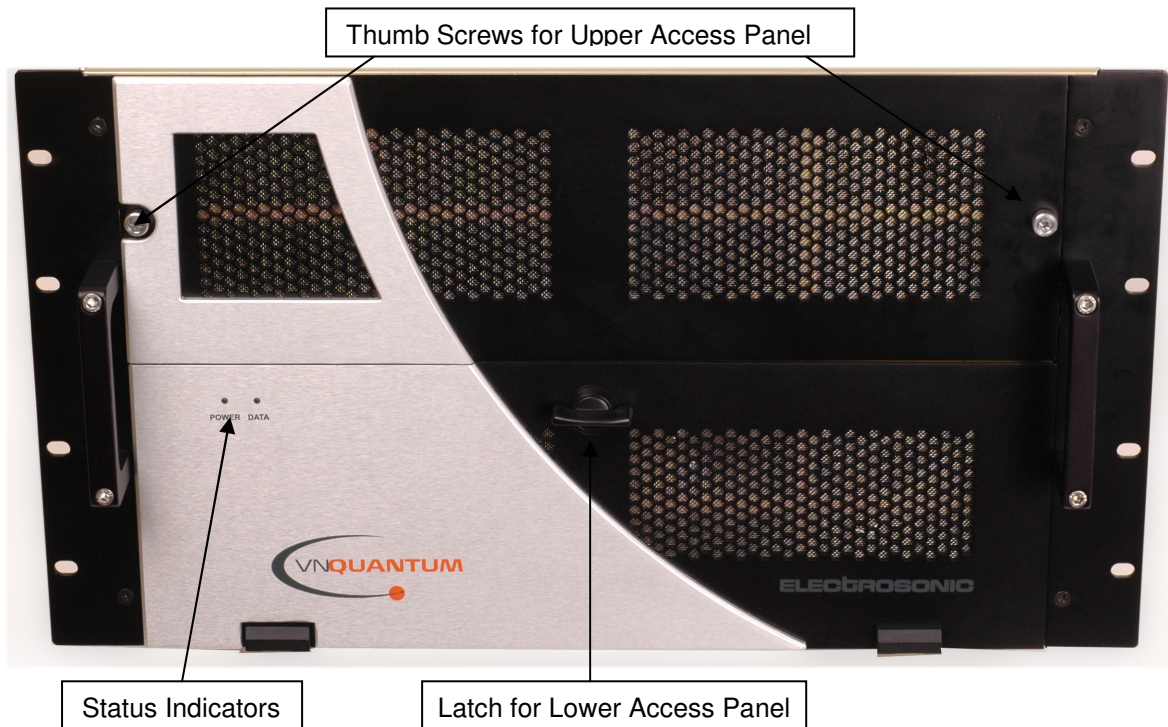

HINT: For full technical details on the Card Frame see page 91.

Status Indicators

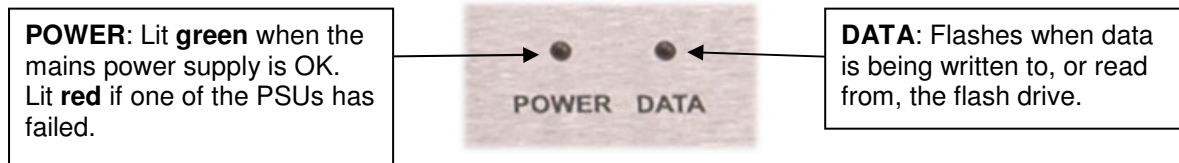

Lower Access Panel & Latch

A fold-down access panel providing access to the following components:

- Power On/Off Button
- System Reset Button
- Flash Drive Bay
- Power Supply Units

The access panel is normally secured in the closed position by a quarter-turn latch.

Power On/Off Button

A rocker switch used to turn the Card Frame power on and off.

O/S Reset Button

A momentary-action rocker switch used to **reset the operating system only**. It does not force a reboot of the Input/Output cards. A full system reboot (*e.g.* as required after installing new firmware) will require a power reset (*i.e.* power off, power on).

Flash Drive

A dual-slot compact flash drive:

- **Top Slot:** Used for Operating System and Hardware Drivers;
- **Bottom Slot:** Used for System Configuration Data. This card can also be used to store local source content (*e.g.* an image file containing a background for the target display).

The drive is normally concealed by a removable cover that is secured by two thumbscrews.

To remove a card, press the button on the right-hand side of the card. To insert a card, simply push the card fully into the slot.

IMPORTANT NOTE: Cards must not be removed or inserted while the system is operational.



Power Supply Units (PSU)

The Card Frame is fitted with two separate PSUs which operate in a redundant PSU configuration. Both PSUs must be fitted and powered ON at all times during normal operation. Should either of the PSUs fail an alarm will sound and the POWER indicator on the front panel will turn red. **Both PSUs must be installed and powered at all times.**

CAUTION: *In the event of a PSU failure, replace the faulty unit as soon as possible (see page 87).*

Upper Access Panel

The top half of the Card Frame front panel is secured by two thumbscrews. Removing this panel gives access to the cooling fans.

Cooling Fans

Four integral fans provide forced-air ventilation, drawing air in through the front panel and exhausting via the rear panel. In the event of a fan failure a replacement fan can be easily hot-swapped via the front panel (see page 88).

CAUTION: *In the event of a fan failure, replace the faulty fan as soon as possible to avoid possible overheating.*

Internal Components

CPU / Operating System

System control is achieved by a single board computer (SBC) running an embedded version of Windows XP with RTX real time extension. This, coupled with the solid-state Flash storage of system data, ensures maximum integrity and reliability of the operating system.

PCI Bus

A standard high-speed PCI bus provides interconnection between all cards. This primarily carries control data, plus local/network source data.

RAPT Image Bus

RAPT (Real-time Asymmetric Packetized Transfer) is a high-speed data bus used exclusively for the transfer of video and RGB Graphics (VN-GLIMPSE) source data between Input and Output Cards.

Unlike PCI technology, RAPT is guaranteed to deliver data in real-time and to remain operational even in the unlikely event of an operating system crash, allowing crucial source content to be maintained on the target display.

Rear Panel Features

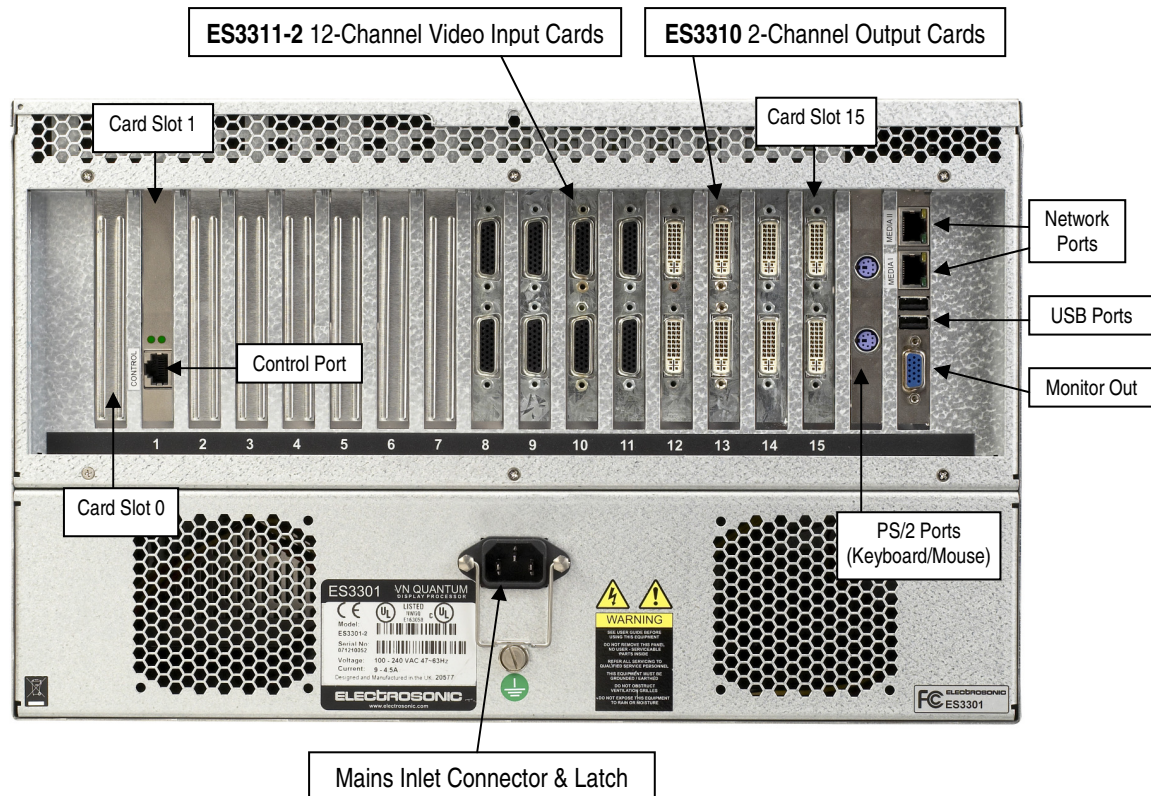

Mains Inlet Connector & Latch

Mains connection to the unit is via this standard IEC 3-pin connector. A latch is provided which hooks over the mains plug to prevent it from becoming accidentally loosened or disconnected.

Network Ports

Two separate Gigabit Ethernet (1000Base-T) ports (labeled MEDIA I and MEDIA II) provided for connection to external local area or wide area networks (LAN or WAN). VN-QUANTUM accesses VN-GLIMPSE sources or network based content via these ports.

Control Port

A single Fast Ethernet (100Base-T) port (labeled CONTROL) for connection to an external control computer, running VN-COMMANDER application software. VN-COMMANDER is used to control the placement of sources on the target display.

Monitor Output

A connector for an optional VGA-compatible display device (*e.g.* a CRT or LCD monitor). This can be used to view internal settings during basic setup, servicing and fault diagnosis procedures. It is not required during normal operation.

PS/2 Ports

Connectors for an optional PS/2-compatible keyboard and/or mouse. These are required for basic system setup and troubleshooting only. Not otherwise required for normal operation.

USB Ports

Can be used to connect additional data storage devices, containing images files or software upgrades. Not otherwise required for normal operation.

8-slot Card Frame

Front Panel (ES3302)

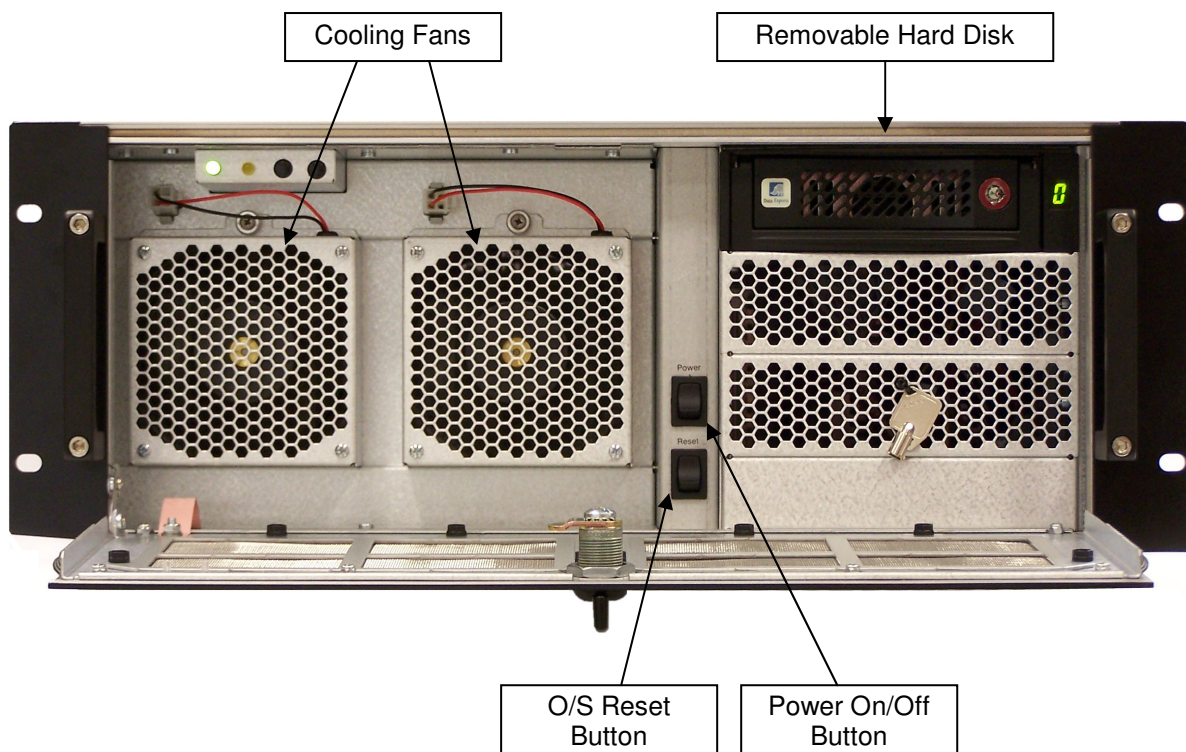
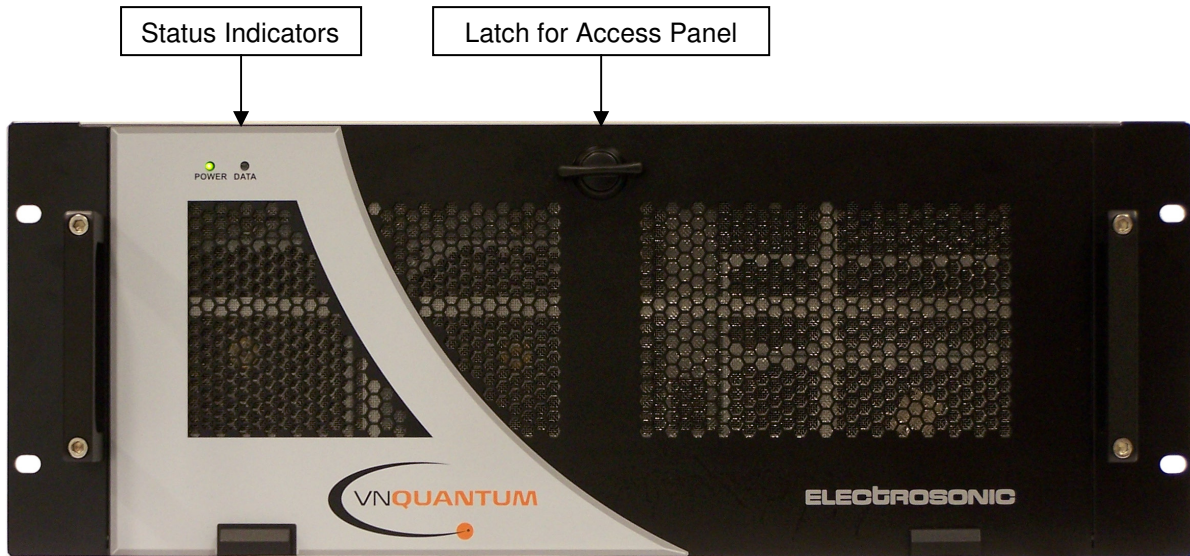

HINT: For full technical details on the Card Frame see page 911.

Front Panel (ES3304 QUANTUM CONNECT)



The ES3304 VN-QUANTUM CONNECT frame has the same physical construction as the ES3302 with a different front panels design.

Front Panel Features

Status Indicators



Lower Access Panel & Latch

A fold-down access panel providing access to the following components:

- Power On/Off Button
- System Reset Button
- Removable Hard Disk Drive

The access panel is normally secured in the closed position by a quarter-turn latch.

Power On/Off Button

A rocker switch used to turn the Card Frame power on and off.

O/S Reset Button

A momentary-action rocker switch used to **reset the operating system only**. It does not force a reboot of the Input/Output cards. A full system reboot (*e.g.* as required after installing new firmware) will require a power reset (*i.e.* power off, power on).

Removable Hard Disk Drive

A 40GB IDE hard disk drive in a removable caddy. The caddy is normally locked in position by a key (supplied). The drive is partitioned and used as follows:

- **C:** for the operating system, and
- **D:** for system configuration files and image files.

NOTE: *This drive is **not** hot-swappable.*

Cooling Fans

Two integral fans provide forced-air ventilation, drawing air in through the front panel and exhausting via the rear panel. In the event of a fan failure a replacement fan can be easily hot-swapped via the front panel (see page 88).

CAUTION: *In the event of a fan failure, replace the faulty fan as soon as possible to avoid possible overheating.*

Internal Components

CPU / Operating System

System control is achieved by a single board computer (SBC) running an embedded version of Windows XP with RTX real time extension.

PCI Bus

A standard high-speed PCI bus provides interconnection between all cards. This primarily carries control data, plus local/network source data.

RAPT Image Bus

RAPT (Real-time Asymmetric Packetized Transfer) is a high-speed data bus used exclusively for the transfer of video and RGB Graphics (VN-GLIMPSE) source data between Input and Output Cards.

Unlike PCI technology, RAPT is guaranteed to deliver data in real-time and to remain operational even in the unlikely event of an operating system crash, allowing crucial source content to be maintained on the target display.

Rear Panel Features

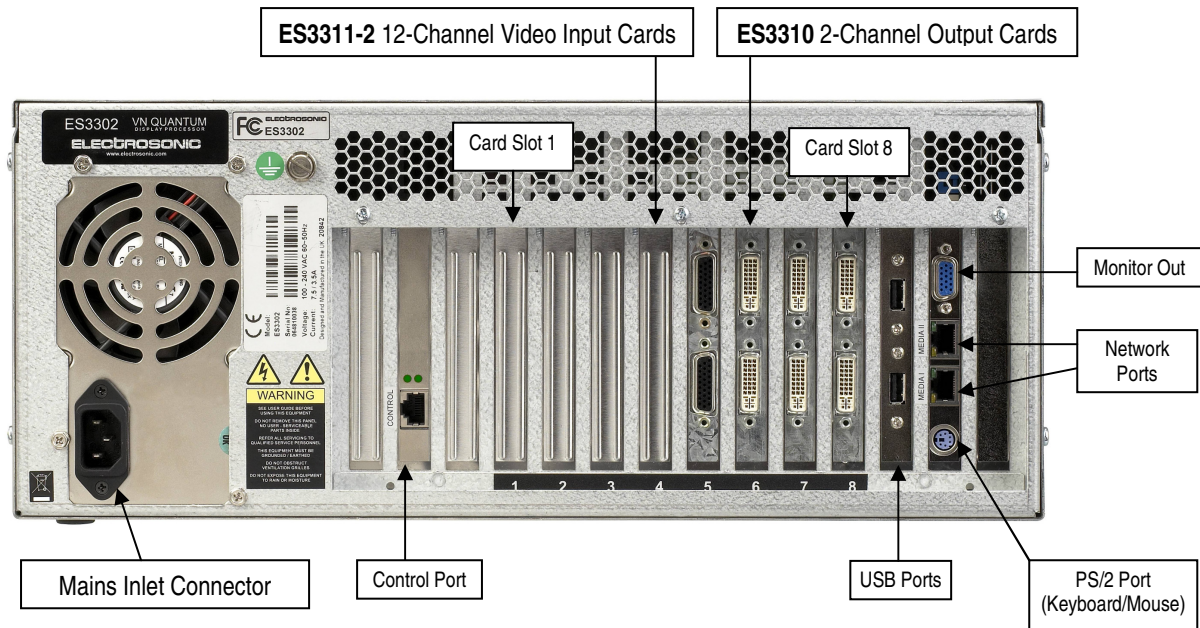

Mains Inlet Connector

Mains connection to the unit is via this standard IEC 3-pin connector.

Network Ports

Two separate Ethernet ports (labeled **MEDIA I** and **MEDIA II**) provided for connection to external local area or wide area networks (LAN or WAN). VN-QUANTUM accesses VN-GLIMPSE sources or network based content via these ports.

MEDIA I is 100Base-T (Fast Ethernet) and **MEDIA II** is 1000Base-T (Gigabit Ethernet).

	<p>Note: The ES3304 VN-QUANTUM CONNECT processor does not support the use of the Media ports (Network interface 1 & 2).</p>
---	---

Control Port

A single Fast Ethernet (100Base-T) port (labeled **CONTROL**) for connection to an external control computer, running VN-COMMANDER application software. VN-COMMANDER is used to control the placement of sources on the target display.

Monitor Output

A connector for an optional VGA-compatible display device (*e.g.* a CRT or LCD monitor). This can be used to view internal settings during basic setup, servicing and fault diagnosis procedures. It is not required during normal operation.

PS/2 Port

A connector for an optional PS/2-compatible keyboard and/or mouse. These are required for basic system setup and troubleshooting only. Not otherwise required for normal operation. A splitter cable is supplied to allow both the keyboard and mouse to be connected to the single socket.

USB Ports

Can be used to connect additional data storage devices, containing images files or software upgrades. Not otherwise required for normal operation.

Input / Output Cards

12-Channel Video Input Card (ES3311-2)

The ES3311-2 Input Card allows external analog video sources to be digitized and used by the VN-QUANTUM Processor.

Each card has 12 source inputs which can be used with either composite video or s-video sources. Full auto-detection is provided on each input, allowing a wide range of standard source types to be connected without the need for any further configuration.

The maximum number of ES3311-2 cards that can be installed is limited only by the number of available card slots (see table on page 57). With the minimum of one Output Card fitted:

- The ES3301-2 Card Frame can accommodate up to 14 Input Cards, allowing a maximum of 168* video source inputs.
- The ES3302 & 3304 Card Frame can accommodate up to 7 Input Cards, allowing a maximum of 84* video source inputs.

The maximum number of video sources that can be **displayed simultaneously is determined by the rectangulation limit of the Output Cards (for further details see page 74).*

For full technical details on the ES3311-2 card, see page 99.

2-Channel RGB Input Card (ES3312)

The ES3312 Input Card allows external analog RGB graphics sources or HD Video sources (in RGB or component YPrPb format) to be digitized and used by the VN-QUANTUM Processor.

Each ES3312 card has 2 source inputs which can be used with either analog RGB or component YPrPb sources. Full auto-detection is provided on each input, allowing a wide range of standard source types to be connected without the need for any further configuration.

The maximum number of ES3312 cards that can be installed is limited only by the number of available card slots (see table on page 57). With the minimum of one Output Card fitted:

- The ES3301-2 Card Frame can accommodate up to 14 Input Cards, allowing a maximum of 28 RGB/HD source inputs.
- The ES3302 & 3304 Card Frame can accommodate up to 7 Input Cards, allowing a maximum of 14 video source inputs.

For full technical details on the ES3312 card, see page 101.

2-Channel DVI Input Card (ES3314)

The ES3314 Input Card allows external digital video or graphics sources to be used by the VN-QUANTUM Processor.

Each ES3314 card has 2 source inputs. Full auto-detection is provided on each input, allowing a wide range of standard source types to be connected without the need for any further configuration.

The maximum number of ES3314 cards that can be installed is limited only by the number of available card slots (see table on page 57). With the minimum of one Output Card fitted:

- The ES3301-2 Card Frame can accommodate up to 14 Input Cards, allowing a maximum of 28 RGB/HD source inputs.
- The ES3302 & 3304 Card Frame can accommodate up to 7 Input Cards, allowing a maximum of 14 video source inputs.

For full technical details on the ES3314 card, see page 102.

2-Channel Output Card (ES3310)

The ES3310 Output Card provides the final output to a target display. The Card composites all sources to be displayed into a layout defined by the VN-COMMANDER software.

The ES3310 card has two output channels, each being capable of driving a 'standalone' display device or one screen element in a larger 'tiled' display (e.g. a videowall).

The output signal format can be either analog (RGB) or digital (DVI) format, up to UXGA resolution, and up to 60Hz refresh rate.

The maximum number of ES3310 cards that can be installed is limited only by the number of available card slots (see table on page 57). With the minimum of one Input Card fitted:

- The ES3301-2 Card Frame can accommodate up to 14 Output Cards, allowing a maximum of 28 display outputs.
- The ES3302 & 3304 Card Frame can accommodate up to 7 Output Cards, allowing a maximum of 14 display outputs.

For full technical details on the ES3310 card, see page 98.

Card Arrangement

VN-QUANTUM Card Frames are configured to order. Therefore, the precise combination and position of cards will vary from system to system and may not be as illustrated on previous pages.

At least one Output Card and one Input Card will be required in all cases but, other than that, any number or mix of Input and Output cards may be used depending on the number of input or output channels required and the number of available slots.

The following tables provide a quick reference for the maximum number of inputs and outputs available for different card combinations, assuming all slots are used:

ES3301-2 (15 slots)

Output Cards ❶	Output Channels	Input Cards ❶	Video Input Channels	RGB/HD/DVI Input Channels
1	2	14	168 ❷	28
2	4	13	156 ❸	26
3	6	12	144	24
4	8	11	132	22
5	10	10	120	20
6	12	9	108	18
7	14	8	96	16
8	16	7	84	14
9	18	6	72	12
10	20	5	60	10
11	22	4	48	8
12	24	3	36	6
13	26	2	24	4
14	28	1	12	2

❶ At least one Input and Output Card must be installed.

❷ A maximum of 64 sources can be viewed *simultaneously* with 1 output card.

❸ A maximum of 128 sources can be viewed *simultaneously* with 2 output cards.

● VN-GLIMPSE sources are transported over IP and do not occupy input card slots.

ES3302 & ES3304 (8 slots)

Output Cards ❶	Output Channels	Input Cards ❶	Video Input Channels	RGB/HD/DVI Input Channels
1	2	7	84 ❷	14
2	4	6	72	12
3	6	5	60	10
4	8	4	48	8
5	10	3	36	6
6	12	2	24	4
7	14	1	12	2

❶ At least one Input and Output Card must be installed.

❷ A maximum of 64 sources can be viewed *simultaneously* with 1 output card

● VN-GLIMPSE sources are transported over IP and do not occupy input card slots.

In a standard configuration, Output Cards are installed in the slots nearest the Single Board Computer (SBC), *i.e.* slot 15 downwards on the ES3301-2 or slot 8 downwards on the ES3302 / 3304. Input Cards are installed in the remaining slots nearest the Output Cards. This arrangement allows every output channel to have access to every video input.

SECTION 3:

Functional Overview

System Overview

The diagram below shows an example system application for a VN-QUANTUM Display Processor.

In this particular application, a selection of video, RGB and network sources can be displayed on a 4-screen target display. The VN-COMMANDER software application is responsible for controlling the VN-QUANTUM and placing the required sources onto the target display.

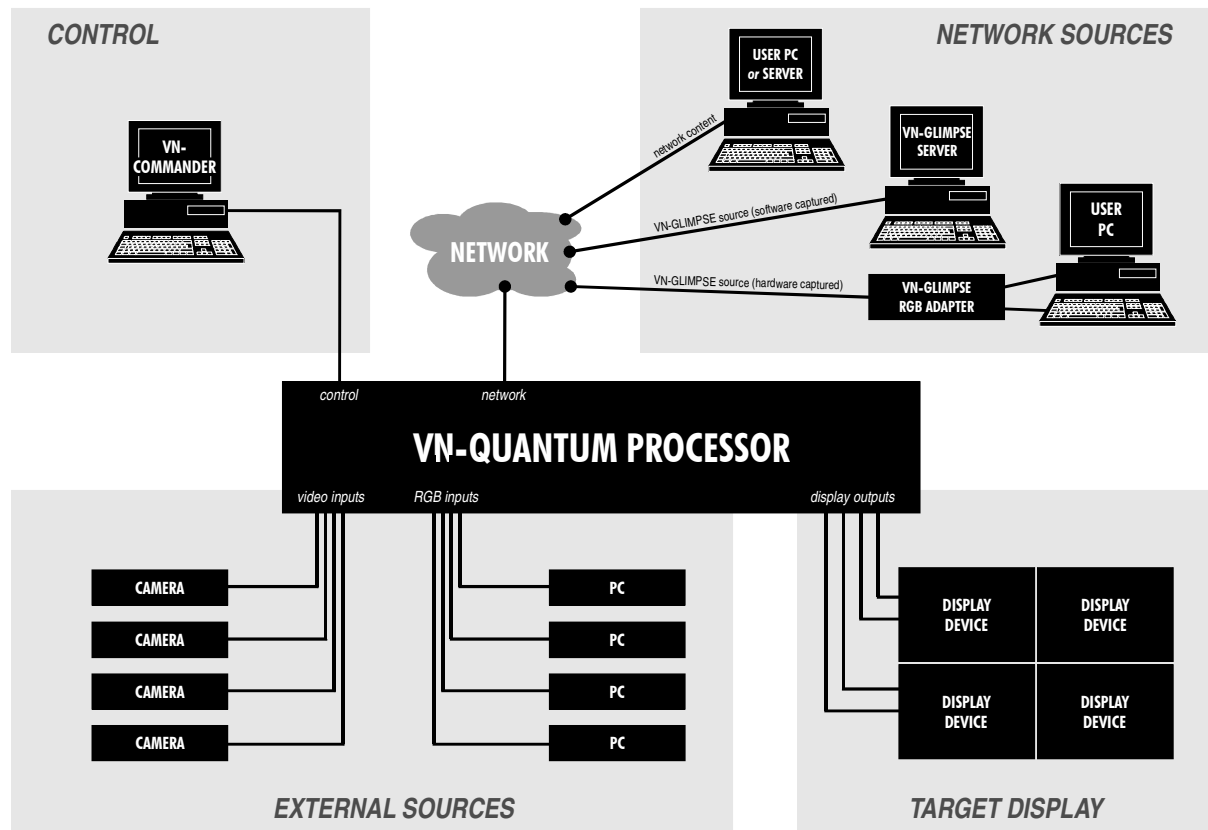

 Note: The ES3304 VN-QUANTUM CONNECT HDD does not support the use of the Media ports (Network interface 1 & 2).

External Sources

Analog video sources, such as cameras, VHS/DVD players and video servers, are input into the VN-QUANTUM Processor through one or more ES3311-2 Input Cards.

Analog RGB graphics or HD Video sources are input into the VN-QUANTUM Processor through one or more ES3312 Input Cards.

12-Channel Video Input Card (ES3311-2)

Card Architecture

The following diagram shows the main functional blocks of the ES3311-2 card and basic data/signal flow through the card:

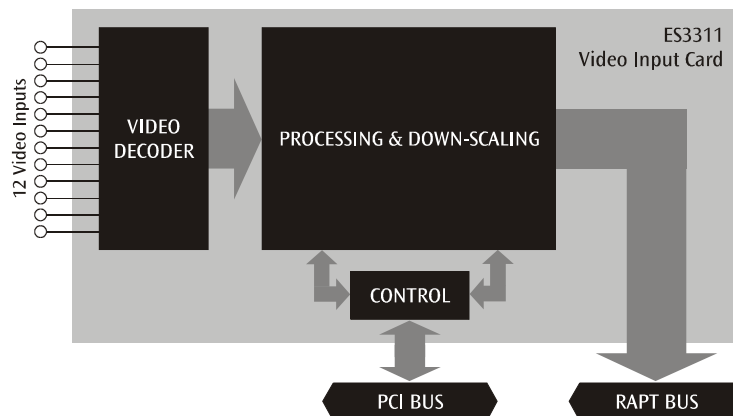

Each ES3311-2 card can accept up to 12 sources of either composite (CVBS) or s-video (YC). The maximum number of cards that can be installed is limited only by the number of available card slots (see table on page 57). With the minimum of one Output Card fitted:

- The ES3301-2 Card Frame can accommodate up to 14 Input Cards, allowing a maximum of 168* video source inputs.
- The ES3302 / 3304 Card Frame can accommodate up to 7 Input Cards, allowing a maximum of 84* video source inputs.

The maximum number of video sources that can be **displayed simultaneously is determined by the rectangulation limit of the Output Cards (for further details see page 74).*

For full technical data on the ES3311-2 Input Card, including connector pin-outs, see page 99.

Auto-detection of Source Types

Full auto-detection is provided on each input, allowing a wide range of standard source types to be connected without the need for any further configuration. However, VN-COMMANDER provides the means to create fixed or custom input modes.

NOTE: *PAL 60 format is not supported. PAL 60 is commonly output by European VCRs when playing back an NTSC tape.*

Automatic gain control (AGC) ensures optimum source display with signals as low as 20% of normal amplitude.

NOTE: *Due to the dynamic nature of AGC an identical source fed to different inputs may not display with identical results.*

Timebase Correction (Frame Synchronization)

Incoming sources are digitized and then synchronized internally to a specified clock signal derived from either:

- The refresh rate of the display outputs; or
- The refresh rate of a designated video source input.

This ensures clean switching between sources without the need for any external source synchronization.

NOTE: *If frame-accurate synchronization is required between some or all sources, these will need to be synchronized externally.*

Macrovision-encoded Sources

Many pre-recorded videos and DVD's are copy-protected by a system called Macrovision®. It works by inserting variable intensity signals into the non-visible region of the source signal. These 'false' signals 'confuse' the AGC circuit of conventional recording devices, preventing the source from being copied satisfactorily.

Typically more than 90% of Macrovision-encoded sources can be viewed successfully. However, certain sources may suffer some visual disturbance or fail to achieve full signal lock.

De-interlacing

VN-QUANTUM outputs a progressive scan to the target display. Most sources that will be connected to the Video Input Card will be interlaced scan and need to be converted to a progressive scan (or 'de-interlaced'). The Video Input Card can use one of two de-interlacing modes:

- Single Field Interpolation
- Three Field Interpolation

For a full explanation of these modes please see page 76.

Down-Scaling of Video Sources

The on-board scaler provides down-scaling (minification) of video sources. Independent horizontal and vertical scaling is possible down to 1/16 of native resolution. For example, a source of 720x486 pixels can be scaled down to around 45x31 pixels.

More than one scaled version of each source is possible, subject to the maximum number of sources supported by the scaler:

Source Type	De-interlacing	Maximum number of Sources Supported (per card)*	
		Real-time	Absolute
Video (PAL/NTSC/SECAM)	Single field	30	64
	Three field	15	64

* Also dependant on the source capacity of the RAPT bus.

The scaling engine is built around Electrosonic's patented convolver technology. This ensures that original image detail and quality is maintained at all times.



Up-scaling (magnification) is achieved by a scaler on the Output Card. See page 75 for further details on source scaling.

Source Transfer

Digitized video sources are transferred on to the RAPT bus for transport to the Output Card(s).

NOTE: VN-GLIMPSE RGB sources use a DMA (Direct Memory Access) process on an ES3311-2 Input Card to transfer source data to the RAPT bus.

Only sources that are currently visible on the target display are transferred to the bus.

2-Channel RGB Input Card (ES3312)

Card Architecture

The following diagram shows the main functional blocks of the ES3312 card and basic data/signal flow through the card:

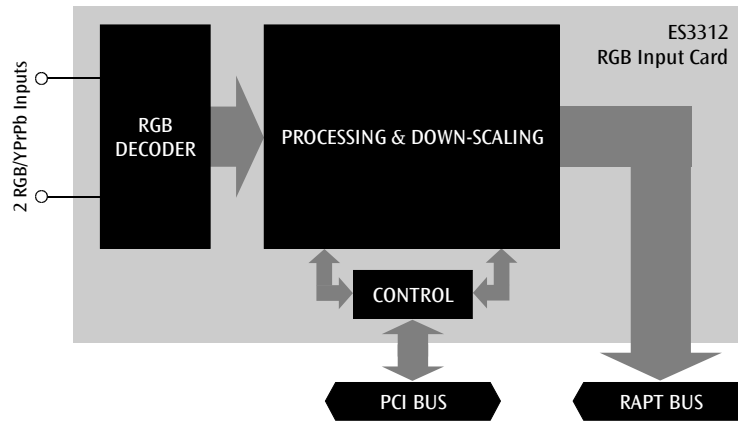

Each card can accept 1 or 2 analog RGB graphics sources or HD Video sources (in RGB or component YPrPb format). The maximum number of ES3312 cards that can be installed is limited only by the number of available card slots (see table on page 57). With the minimum of one Output Card fitted:

- The ES3301-2 Card Frame can accommodate up to 14 Input Cards, allowing a maximum of 28 RGB/HD source inputs.
- The ES3302 & 3304 Card Frame can accommodate up to 7 Input Cards, allowing a maximum of 14 RGB/HD source inputs.

For full technical data on the ES3312 Input Card, including connector pin-outs, see page 10101.

Auto-detection of Source Types

Full auto-detection is provided on each input, allowing a wide range of standard source types to be connected without the need for any further configuration. However, VN-COMMANDER provides the means to create fixed or custom input modes.

Timebase Correction (Frame Synchronization)

Incoming sources are digitized and then synchronized internally to a specified clock signal derived from either:

- The refresh rate of the display outputs; or
- The refresh rate of a designated VIDEO source input (from an ES3311-2 card).

This ensures clean switching between sources without the need for any external source synchronization.

NOTE: *If frame-accurate synchronization is required between some or all sources, these will need to be synchronized externally.*

De-interlacing

VN-QUANTUM outputs a progressive scan to the target display. Most sources that will be connected to the RGB Input Card will be progressive scan and will not require any special processing. However, certain HD Video signals have an interlaced scan which will be converted to a progressive format using one of two de-interlacing modes:

- Single Field Interpolation
- Three Field Interpolation

For a full explanation of these modes please see page 76.

Down-Scaling of RGB / HD Video Sources

The on-board scaler provides down-scaling (minification) of RGB/HD sources. Independent horizontal and vertical scaling is possible down to 1/16 of native resolution. For example, a source of 1600x1200 pixels can be scaled down to around 100x75 pixels.

More than one scaled version of each source is possible, subject to the maximum number of sources supported by the scaler:

Source Type	De-interlacing	Maximum number of Sources Supported (per card)*		
		Real-time		Absolute
		50Hz	60Hz	
HD 1080i	Single field	7	5	64
	Three field	3	2	64
HD 1080p	n/a	3	2	64
HD 720p	n/a	8	6	64
UXGA	n/a	3	3	64
SXGA+	n/a	5	4	64
SXGA	n/a	5	4	64
WXGA	n/a	7	6	64
XGA	n/a	9	7	64
SVGA	n/a	15	12	64

* Also dependant on the source capacity of the RAPT bus.

The scaling engine is built around Electrosonic's patented convolver technology. This ensures that original image detail and quality is maintained at all times.



Up-scaling (magnification) is achieved by a scaler on the Output Card. See page 75 for further details on source scaling.

Source Transfer

Digitized RGB sources are transferred on to the RAPT bus for transport to the Output Card(s).

Only sources that are currently visible on the target display are transferred to the bus.

2-Channel DVI Input Card (ES3314)

Card Architecture

The following diagram shows the main functional blocks of the ES3314 card and basic data/signal flow through the card:

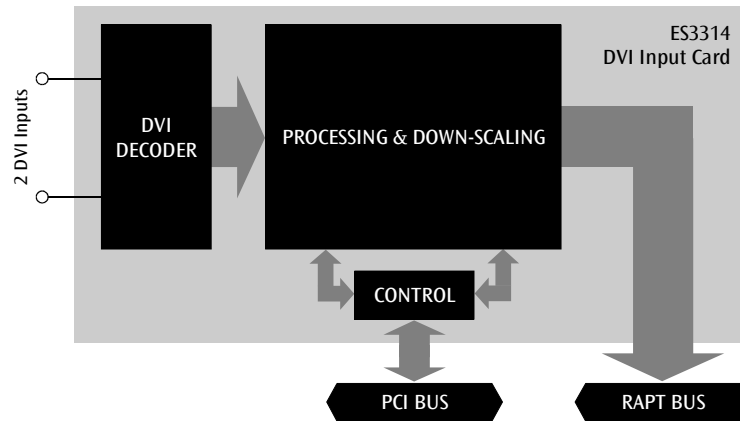

Each card can accept 1 or 2 DVI sources. The maximum number of ES3314 cards that can be installed is limited only by the number of available card slots (see table on page 57). With the minimum of one Output Card fitted:

- The ES3301-2 Card Frame can accommodate up to 14 Input Cards, allowing a maximum of 28 DVI source inputs.
- The ES3302 & 3304 Card Frame can accommodate up to 7 Input Cards, allowing a maximum of 14 DVI source inputs.

For full technical data on the ES3314 Input Card, including connector pin-outs, see page 102.

Auto-detection of Source Types

Full auto-detection is provided on each input, allowing a wide range of standard source types to be connected without the need for any further configuration. However, VN-COMMANDER provides the means to create fixed or custom input modes.

Timebase Correction (Frame Synchronization)

Incoming sources are digitized and then synchronized internally to a specified clock signal derived from either:

- The refresh rate of the display outputs; or
- The refresh rate of a designated VIDEO source input (from an ES3311-2 card).

This ensures clean switching between sources without the need for any external source synchronization.

NOTE: *If frame-accurate synchronization is required between some or all sources, these will need to be synchronized externally.*

De-interlacing

VN-QUANTUM outputs a progressive scan to the target display. Most sources that will be connected to the DVI Input Card will be progressive scan and will not require any special processing. However, certain HD Video signals have an interlaced scan which will be converted to a progressive format using one of two de-interlacing modes:

- Single Field Interpolation
- Three Field Interpolation

For a full explanation of these modes please see page 76.

Down-Scaling of DVI Video Sources

The on-board scaler provides down-scaling (minification) of DVI sources. Independent horizontal and vertical scaling is possible down to 1/16 of native resolution. For example, a source of 1600x1200 pixels can be scaled down to around 100x75 pixels.

More than one scaled version of each source is possible, subject to the maximum number of sources supported by the scaler:

Source Type	De-interlacing	Maximum number of Sources Supported (per card)*		
		Real-time		Absolute
		50Hz	60Hz	
HD 1080i	Single field	7	5	64
	Three field	3	2	64
HD 1080p	n/a	3	2	64
HD 720p	n/a	8	6	64
UXGA	n/a	3	3	64
SXGA+	n/a	5	4	64
SXGA	n/a	5	4	64
WXGA	n/a	7	6	64
XGA	n/a	9	7	64
SVGA	n/a	15	12	64

* Also dependant on the source capacity of the RAPT bus.

The scaling engine is built around Electrosonic's patented convolver technology. This ensures that original image detail and quality is maintained at all times.



Up-scaling (magnification) is achieved by a scaler on the Output Card. See page 75 for further details on source scaling.

Source Transfer

DVI sources are transferred on to the RAPT bus for transport to the Output Card(s).

Only sources that are currently visible on the target display are transferred to the bus.

Network Sources

VN-GLIMPSE RGB Graphics Sources

Applications running on remote computers can be 'captured' using VN-GLIMPSE.

This is ELECTROSONIC's patented technology for the efficient lossless transportation of RGB computer graphics over a standard IP network. VN-GLIMPSE can capture the desktop of the 'source computer' using either of the following devices:

- The **VN-GLIMPSE SERVER** is a software-based capture application and is directly installed on the source computer. It is best suited to sources with low motion content. Note that during a capture session some loss in speed/performance of the computer may be experienced. The degree to which the computer will be affected is dependent on a number of factors, including CPU speed and graphics card type. Refer to the VN-GLIMPSE SERVER User Guide for further details.
- The **VN-GLIMPSE RGB ADAPTER** is a hardware-based capture device and connects between the keyboard, mouse and monitor on the source computer. It provides the same graphics capture capability as the VN-GLIMPSE SERVER but does not have any adverse effect on the speed/performance of the source computer. It is best suited to sources with low to moderate motion content. Refer to the VN-GLIMPSE RGB ADAPTER User Guide for further details.

The VN-QUANTUM Processor can connect to any VN-GLIMPSE source (via one of its network ports – see page 32) and display it on the target display.

	Note that the VN-QUANTUM CONNECT processor does not support the use of the MEDIA I and II ports.
---	--

Source Transfer

VN-GLIMPSE sources are delivered to VN-QUANTUM over an IP network. A DMA (Direct Memory Access) process is used on an ES3311-2 Video Input Card to transfer source data from the PCI bus to the RAPT bus. For this reason at least one ES3311-2 Card must be installed in every VN-QUANTUM Card Frame.

NOTE: *By using VN-GLIMPSE lossless compression, RGB data bandwidth is dramatically reduced and results in more efficient use of the RAPT bus.*

	Note: The ES3304 VN-QUANTUM CONNECT processor does not support the use of VN-GLIMPSE sources.
---	---

Image Files

VN-QUANTUM can display certain types of image files as 'sources' on the target display. Any number of Image file sources can be used simultaneously (subject to available space on the display).

File types currently supported include:

- Windows Bitmaps (BMP)
- JPEG Images (JPG)
- Compuserve Bitmaps (GIF)
- Portable Network Graphics (PNG)

Additional plug-ins may be made available to special order to allow other file types to be displayed.

HINT: *Using the VN-GLIMPSE SERVER or RGB ADAPTER, it is possible for **any** application running on a remote computer to be captured and displayed as a source (see page 67).*

To be able to display the specified image source you need to ensure that VN-QUANTUM can actually 'see' the image file via one of the following:

- Via an external USB drive (recommended method)
- Via the local flash drive.
- Via a local network.

HINT: *For further advice on using image files with VN-QUANTUM, please refer to the Technical Information Note no. TIN114. A copy of this can be found in the Documents folder of the VN-QUANTUM System Disc or in the Product Support area of the Electrosonic Web Site.*

	Note: The ES3304 VN-QUANTUM CONNECT processor uses a different HDD image. The HDD does not support the use of the Image files.
---	---

RAPT Image Bus

RAPT (Real-time Asymmetric Packetized Transfer) is a high-speed data bus used exclusively for the transfer of digitized video and RGB source data between Input and Output Card(s). It is also used to carry any VN-GLIMPSE sources to the Output Card(s).

Unlike PCI technology, RAPT is guaranteed to deliver data in real-time and to remain operational even in the unlikely event of an operating system crash, allowing crucial source content to be maintained on the target display.

Guaranteed Real-Time Performance

Real-time performance of the RAPT bus is defined as the ability to display a source at its full temporal resolution (*i.e.* maintaining the same scan rate as the original source, without dropping any fields or frames).

The RAPT bus can carry the equivalent of 48 full-resolution, full-motion video sources in real-time, using 4:2:2 sampling and single-field de-interlacing, as summarized in the following table:

Source Type	Sampling	De-interlacing	Maximum number of Real-time Sources	
			50Hz	60Hz
NTSC	4:2:2*	Single field	–	48
		Three field	–	24
PAL/SECAM	4:2:2*	Single field	48	–
		Three field	24	–
HD 1080i	4:4:4	Single field	8	6
		Three field	4	3
HD 1080p	4:4:4	n/a	4	3
HD 720p	4:4:4	n/a	9	7
UXGA	4:4:4	n/a	4	3
SXGA+	4:4:4	n/a	5	4
SXGA	4:4:4	n/a	6	5
WXGA	4:4:4	n/a	8	7
XGA	4:4:4	n/a	10	8
SVGA	4:4:4	n/a	17	14

*4:2:2 is the default sampling rate for SD video. 4:4:4 is available as an option but in most cases this will not offer significant improvement in image quality and will reduce the maximum number of sources by around 33%.

The maximum number of sources can be greatly increased when displaying sources at less than their native spatial resolution. For example, if sources are displayed at one quarter of their native spatial resolution, four times as many sources can be accommodated on the RAPT bus while preserving full temporal resolution:

Source Format		Max. No. of Real-time Sources
Resolution	De-interlacing	
Full Native Resolution	Single field	48
NTSC (720x480)	Three field	24
PAL/SECAM (720x576)		
Quarter Resolution ①	Single field	192 ②
NTSC (360x240)	Three field	96
PAL/SECAM (360x288)		

① Scaled-down by Input Card.

② A maximum of 144 sources can be viewed *simultaneously* by using 12 input cards and 3 output cards.

RAPT Bandwidth Management

In the unlikely event that the number of sources displayed on the target display exceeds the real-time capacity of the RAPT bus, VN-QUANTUM implements a system of bandwidth management.

All sources are processed at the full temporal rate of the system. This is the rate at which the displays run, either 50 or 60Hz.

The RAPT bandwidth usage is monitored dynamically. Whenever the number of sources viewed causes the RAPT bandwidth to be exceeded, the source update rate is lowered to half the full temporal rate. When the RAPT bandwidth usage reduces to a point below its maximum, the source update is increased to its full rate.

Note that the display output continues to run at selected refresh rate (either 50 or 60Hz).

Target Display

The target display can comprise a single screen (using a single output channel) or a larger tiled display comprising two or more screens butted together.

Final output from the VN-QUANTUM to the target display is achieved via one or more ES3310 Output Cards.

ES3310 2-Channel Output Card

Card Architecture

The following diagram shows the main functional blocks of the ES3310 card and basic data/signal flow through the card:

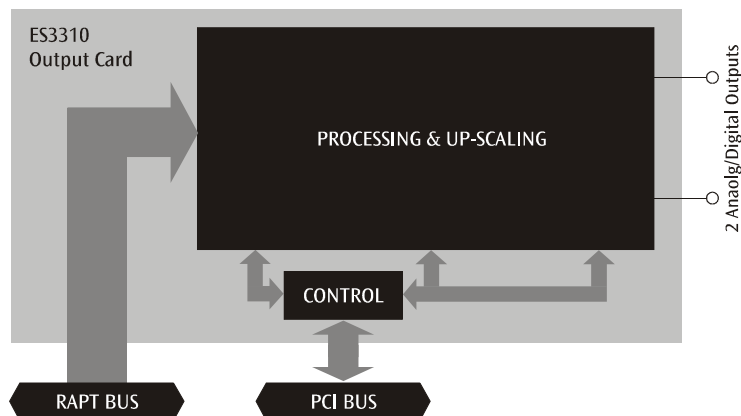

Each ES3310 card has two output channels, with each channel designed to drive a separate element/screen in the target display. The maximum number of ES3310 cards that can be installed is limited only by the number of available card slots (see table on page 57). With the minimum of one Input Card fitted:

- The ES3301-2 Card Frame can accommodate up to 14 Output Cards, allowing a maximum of 28 display outputs.
- The ES3302 & 3304 Card Frame can accommodate up to 7 Output Cards, allowing a maximum of 14 display outputs.

For full technical data on the ES3310 Output Card, including connector pin-outs, see page 98

Source Delivery

Sources are delivered to the Output Card either via the RAPT bus or via the PCI bus:

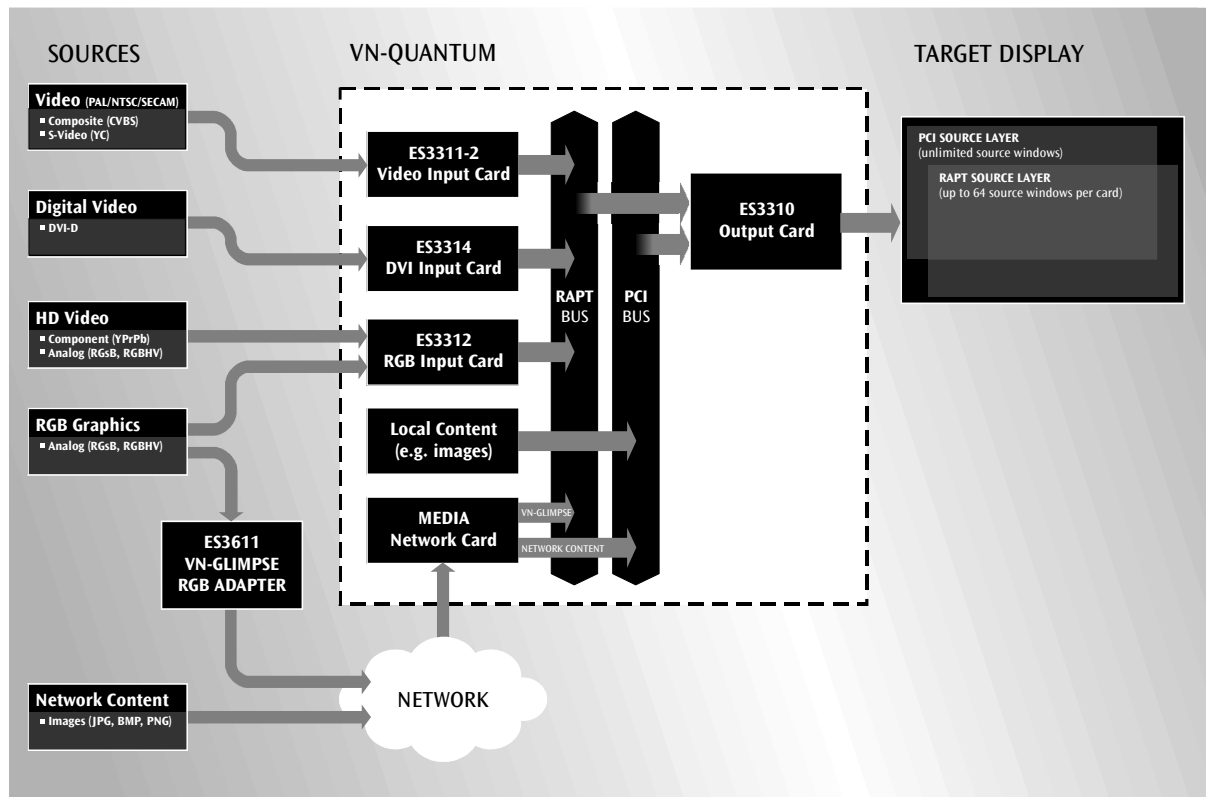

Source Palette

All Output Cards have access to all sources available on the RAPT and PCI buses. Each card has the capacity to decode, process and display the following sources:

Source Type	Maximum number of Sources Supported (per card)*		
	Real-time	Absolute	
Video (PAL/NTSC/SECAM)	64	64	
Analog RGB	<i>tba</i>	64	
Component YPrPb	<i>tba</i>	64	
VN-GLIMPSE RGB	UXGA	2 @60Hz	13
	SXGA	<i>tba</i>	16
	XGA	<i>tba</i>	42
Image Files	unlimited	unlimited	

* Subject to RAPT/PCI capacity, window layout and desired performance.

Up-Scaling

The on-board scaler provides up-scaling (magnification) of video, RGB and VN-GLIMPSE sources. Independent horizontal and vertical scaling is possible up to 16x native resolution. For example, a source of 720x486 pixels can be scaled up to around 11520x7776 pixels.

The scaling engine is built around Electrosonic's patented convolver technology which ensures that original image detail and quality is maintained at all times.



Down-scaling (minification) of video, RGB and DVI sources is achieved by a scaler on the Input Card. See page 75 for further details on source scaling.

NOTE: *Where image files need to be up-scaled, these are rendered at the appropriate size by the on-board graphics processor (GPU). This ensures maximum image sharpness.*

Output Channels

Two output channels are provided which can be used to drive separate displays or individual screen elements within a larger tiled display.

In a tiled display, each Output Card channel pair can be configured to output any region of the overall display.

All outputs are compatible with analog or digital display devices. Output resolution is adjustable up to UXGA (1600 x 1200 pixels) and 1920 x 1080p with refresh rates of 50 or 60Hz.

Understanding the Display Architecture

When VN-QUANTUM is controlled by VN-COMMANDER, sources are placed on the display in 'windows' which are fully resizable and can be positioned anywhere on the display.

NOTE: VN-QUANTUM 'remembers' the last display layout in force before being powered-down. Prior to shipping all new VN-QUANTUM systems have a single, full-size window, placed on the display containing a VN-QUANTUM logo design. This logo is stored on the internal flash drive/hard disk.



For further details on controlling source window content, size and positioning please refer to the VN-COMMANDER User Guide.

The architecture of the target display effectively comprises two 'layers':

- **PCI source layer** which is used to display sources delivered via the PCI bus, *i.e.* local or network-based images, and
- **RAPT source layer** which is used to display sources delivered via the RAPT bus, *i.e.* digitized sources from the Input Cards and VN-GLIMPSE sources.

When no source windows are present, the PCI source layer is black and the RAPT source layer fully transparent, thus making the entire display appear black.

The layer on which source windows get placed is determined automatically by VN-QUANTUM and VN-COMMANDER, and needs no user intervention. However, it is important to understand the maximum number of windows that can be displayed on each layer.

Rectangulation Limit (RAPT Source Layer)

There is no limit to the number of source windows that can be placed on the PCI source layer.

However, the maximum number of windows that can be displayed at one time on the RAPT source layer is dependant on a 'rectangulation limit'. In simple terms this relates to the maximum number of rectangles needed to draw the display layout. For example, the following display layouts both use two windows, but note the different number of rectangles used to draw each layout:

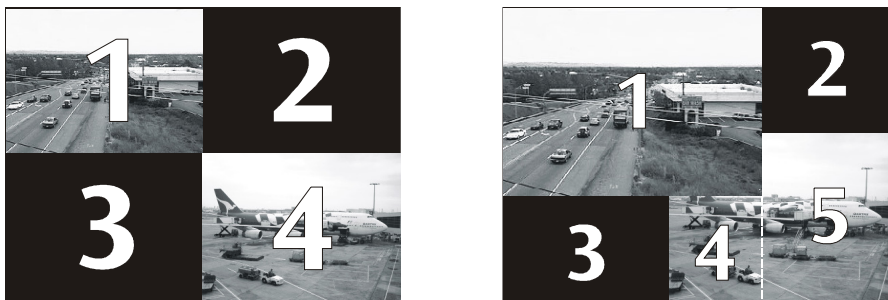

From this example you can see that, in terms of using the least number of rectangles, the *most efficient* display layout is for the source windows to be displayed as an array, *i.e.* with no gaps or overlaps.

The ES3310 Output Card can support layouts that require a maximum of 64 rectangles *in total* shared between both output channels, *e.g.* 32 on each channel or 64 on one channel.

Therefore, up to 64 video, RGB, DVI and/or VN-GLIMPSE sources can be displayed on single screen, assuming the rectangulation limit is not exceeded.

Advanced Operating Principles

Source Scaling

VN-QUANTUM allows video, RGB and DVI sources to be scaled up or down in size by using the scalers on the Input and Output Cards.

- Down-scaling or 'minification' is performed by the Input Card and can be up to 16 times smaller (both horizontally and/or vertically) than the original source.
- Up-scaling or 'magnification' is performed by the Output Card and can be up to 16 times bigger (both horizontally and/or vertically) than the original source.

For simplicity, the examples in the following diagrams assume that each screen in the target display has the same resolution as the source:

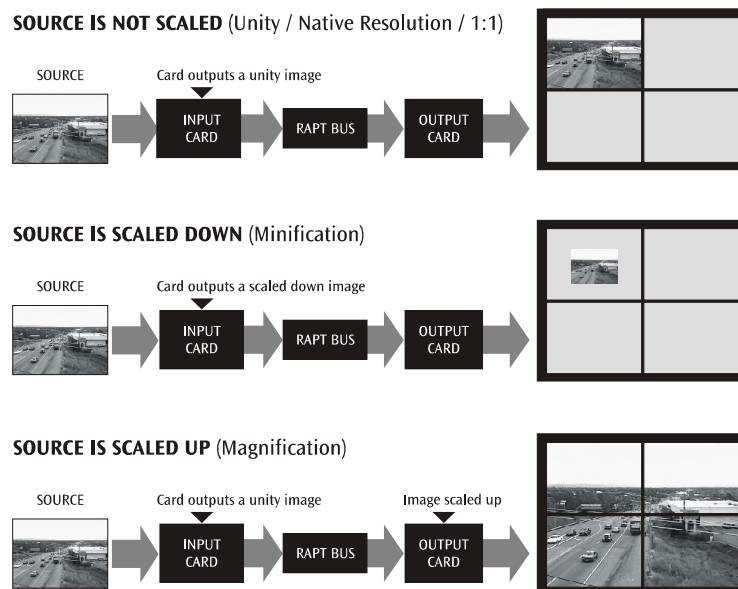

NOTE: Sources emanating from the PCI bus (e.g. image files) are scaled (up or down) to the appropriate size by the Output Card graphics processor (GPU).

De-interlacing

VN-QUANTUM outputs a progressive scan to the target display. Therefore, incoming interlaced sources are converted to a progressive format using one of two de-interlacing modes:

- **Single Field Interpolation:** each field from the interlaced source is transferred separately across the RAPT bus. The 'missing' lines from each field are then interpolated by the Output Card to produce a new progressive frame.

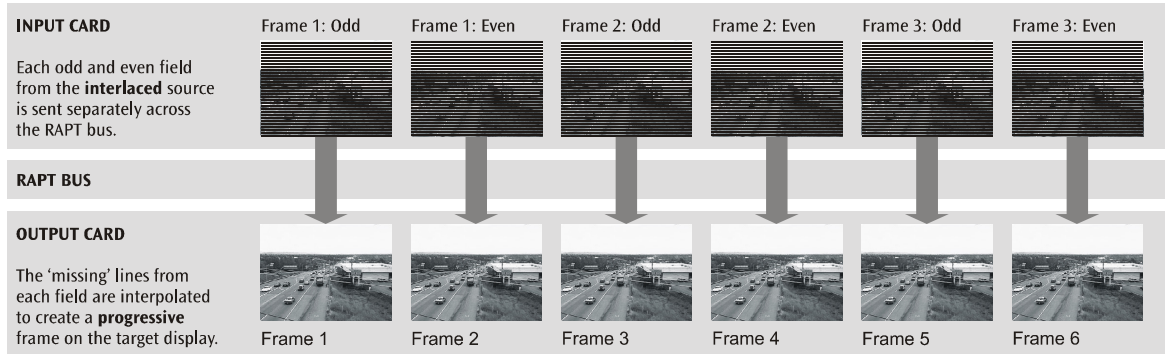

- **Three Field Interpolation:** the Input Card analyzes adjacent field pairs from the interlaced source and interpolates a new ('third') progressive frame which is transferred across the RAPT bus.

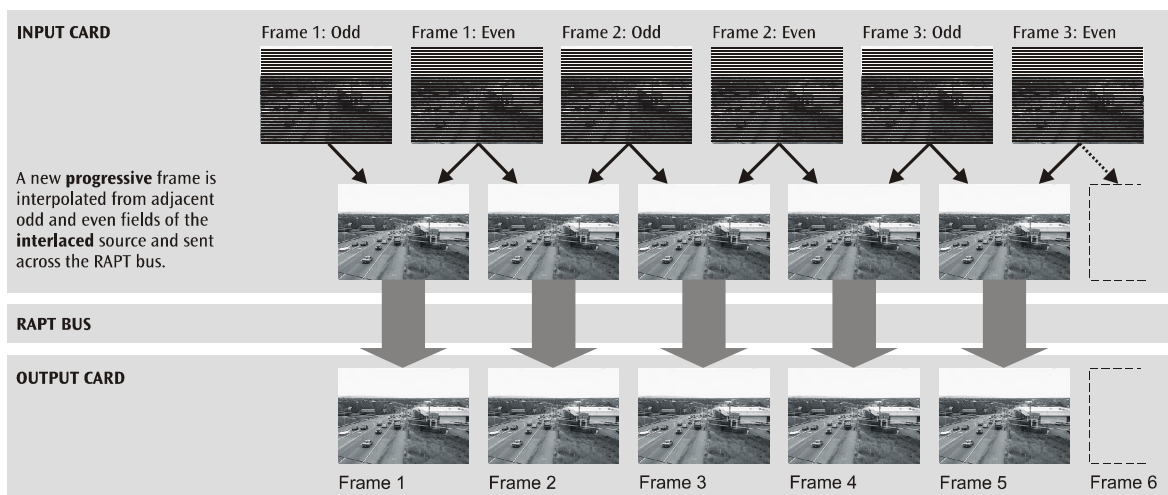

The best mode to use will depend on the content of the original source and the number of sources that need to be transported on the RAPT bus. This is summarized as follows:

	Single Field Interpolation	Three Field Interpolation
Source Content	More suited to high-motion content. Generally results in a sharper image on the display.	More suited to low-motion or static content, especially text. Generally results in a smoother/softer image on the display.
RAPT Bandwidth	More Single Field sources can be displayed in real-time than Three Field sources.	Less Three Field sources can be displayed in real-time than Single Field sources.

Input & Output Card Grouping

In a standard configuration all Input and Output Cards are grouped together in the Card Frame. For example:

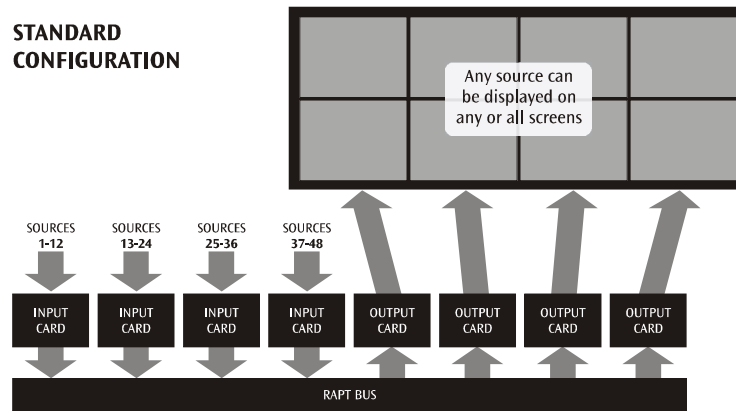

The RAPT bus can transport up to 48 real-time sources

This arrangement allows each video input to be displayed on any (or all) output channels. The maximum number of real-time sources that can be displayed is limited by the capacity of the RAPT (typically 48 full-resolution, full motion video sources). Note that RAPT bandwidth management allows the number of sources to exceed the maximum bandwidth.

Control

Low-level setup of VN-QUANTUM (*e.g.* changing network settings) can be achieved using either the VN-QUANTUM Control Panel application or the VN-QUANTUM Administrator running on a separate PC.

All high-level setup (*e.g.* display and source configuration) and positioning of source windows on the target display is achieved using the VN-COMMANDER application.

VN-QUANTUM Control Panel

This is an application that runs on the VN-QUANTUM processor. It is accessed by connecting a keyboard, mouse and monitor to the card frame. See pages 33 – 36 for further details.

VN-COMMANDER (Quantum Edition)

VN-COMMANDER is a simple-to-use Windows-based software application that is used to provide high-level configuration of the VN-QUANTUM and to provide full user control of the target display. The VN-COMMANDER computer connects to the CONTROL port on the card frame (see page 37).

Using VN-COMMANDER you can:

- Change the output configuration, *e.g.* resolution, refresh rate.
- Define the physical layout of the target display.
- Define source names and setup.
- Design different source layouts ('scenes') on the target display.
- Recall particular scenes with a simple user-definable control panel.

VN-COMMANDER scenes can also be recalled using remote control (see page 79).

VN-COMMANDER is installed using the VN-QUANTUM System Disc (see page 38).

Full details on using VN-COMMANDER can be found its own User Guide which is also available on the System Disc.

	Note: The ES3304 VN-QUANTUM CONNECT requires the use of the VN-COMMANDER CONNECT control software.
---	--

Remote Control

of VN-COMMANDER

VN-COMMANDER can be remotely controlled using RS-232 serial strings. These allow full control of scene selection as well as window size, positioning and contents. Control strings may be generated by various means.

In addition, VN-COMMANDER can be controlled by an automation client. This allows customized user interfaces to be created for specific applications. For further details on using automation, please contact Electrosonic.

of External Devices

VN-COMMANDER provides the ability to control external devices via RS-232 or Ethernet. Control commands can be included with each scene such that the commands are automatically transmitted when the scene is recalled.

Using suitable interfaces these commands can be used to control external source devices (*e.g.* DVD/VHS players or source switchers) or environmental control subsystems (*e.g.* lighting, blinds, *etc.*)

Understanding the Capabilities of VN-QUANTUM

Overview

VN-QUANTUM is a highly versatile system capable of displaying a large number of sources in real-time on a target display. As with any system there are certain limitations and this section is intended to help you understand those limits and how they relate to some real world applications

There are three key limiting factors which will ultimately affect system capabilities:

- **Number of Card Slots:** The number of Input and Output Cards will determine how many video inputs and display outputs are available. The ES3301-2 Card Frame can accommodate up to 15 cards and the ES3302 & 3304 a maximum of 8 cards.
- **RAPT Bandwidth:** The RAPT bus carries video and RGB source data between the Input Cards and the Output Cards. The RAPT can carry the equivalent of 48 full resolution video sources in real-time. If more data needs to be transported, a scheme of bandwidth management is implemented.
- **Rectangulation Limit:** The maximum number of source windows that can be displayed by a single Output Card and cannot exceed 64 rectangles per output channel pair. The maximum of 64 source windows is achieved by displaying 64 windows as an array on a single output channel (as shown in Scenario 1 on page 81).

Example Scenarios

The follow example scenarios illustrate various applications that might be required in the real world. For each scenario, the effect on the three factors described above is shown using three bargraphs.

Wherever possible, the layout examples show source windows at their normal aspect ratio. Some windows are shown stretched horizontally or vertically to make optimum use of the display space. RAPT bandwidth and Rectangulation usage are based on the window layout shown. Window layouts can be changed to suit specific applications, but different layouts will alter the usage values given.

Scenario 1 – Maximum number of video sources on a single screen

Screen Layout

A single UXGA display device is used to display 64 video source windows arranged as an 8x8 array. The total display size is 1600x1200 pixels, making each window 200x150 pixels.

1	2	3	4	5	6	7	8
9	10	11	12	13	14	15	16
17	18	19	20	21	22	23	24
25	26	27	28	29	30	31	32
33	34	35	36	37	38	39	40
41	42	43	44	45	46	47	48
49	50	51	52	53	54	55	56
57	58	59	60	61	62	63	64

Because each window is smaller than the native source resolution, each source is scaled down to the required size by the Input Card. This greatly reduces the amount of source data needing to be transferred across the RAPT bus to the Output Card and allows a large number of sources to be displayed simultaneously in real-time.

Hardware Requirements

- 1 Output Card (only one output channel is used to drive a single UXGA screen)
- 6 Input Cards (providing 72 source inputs – only 64 can be viewed simultaneously)
- An ES3301-2 or ES3302 & 3304 Card Frame.

System Capacity

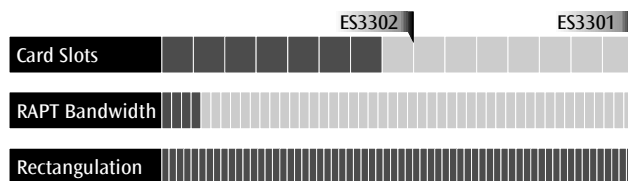

The limit of 64 source windows is imposed by the rectangulation limit of the Output Card. All sources are displayed in real-time.

RAPT bandwidth usage assumes that all sources are using single-field de-interlacing. Using three-field de-interlacing will double the amount of source data but the real-time RAPT limit will never be exceeded.

Expansion Options

If you are using the ES3301-2 Card Frame there are 8 spare card slots, so you could add a second Output Card and five more Input Cards to create a second display also showing 64 sources, giving 128 in total.

Alternatively, you could just add further Input Cards to increase the *choice* of sources available for display.

Scenario 2 – Maximum number of Full Res video sources on a tiled display

Screen Layout

12 UXGA display devices are used to create a 4x3 tiled display. 48 video source windows are arranged as an 8x6 array. The total display size is 6400x3600 pixels, making each window 800x600 pixels.

1	2	3	4	5	6	7	8
9	10	11	12	13	14	15	16
17	18	19	20	21	22	23	24
25	26	27	28	29	30	31	32
33	34	35	36	37	38	39	40
41	42	43	44	45	46	47	48

Because each window is larger than the native source resolution, each source is transferred across the RAPT at its native resolution and then scaled up to the required size by the Output Card.

Hardware Requirements

- 6 Output Cards (driving 12 UXGA screens)
- 4 Input Cards (providing 48 source inputs)
- An ES3301-2 Card Frame.

System Capacity

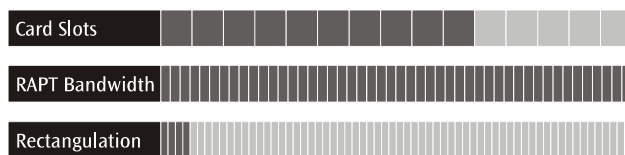

The limit of 48 real-time source windows is imposed by the available RAPT bandwidth and the available screen space. This assumes that all sources are using single-field de-interlace and are sampled at 4:2:2.

Expansion Options

There are five spare card slots so you could add further Output Cards to add more screens or further Input Cards to increase the choice of sources.

Increasing the number of full resolution source windows will exceed the real-time limit of the RAPT bus, so VN-QUANTUM will implement its bandwidth management scheme.

Scenario 3 – Maximum number of video sources on a tiled display

Screen Layout

6 UXGA display devices are used to create a 3x2 tiled display. 144 video source windows are arranged as a 12x12 array. The total display size is 4800x2400 pixels, making each window around 133x100 pixels.

1	2	3	4	5	6	7	8	9	10	11	12
13	14	15	16	17	18	19	20	21	22	23	24
25	26	27	28	29	30	31	32	33	34	35	36
37	38	39	40	41	42	43	44	45	46	47	48
49	50	51	52	53	54	55	56	57	58	59	60
61	62	63	64	65	66	67	68	69	70	71	72
73	74	75	76	77	78	79	80	81	82	83	84
85	86	87	88	89	90	91	92	93	94	95	96
97	98	99	100	101	102	103	104	105	106	107	108
109	110	111	112	113	114	115	116	117	118	119	120
121	122	123	124	125	126	127	128	129	130	131	132
133	134	135	136	137	138	139	140	141	142	143	144

Because each window is smaller than the native source resolution, each source is scaled down to the required size by the Input Card. This greatly reduces the amount of source data needing to be transferred across the RAPT bus to the Output Card and allows a large number of sources to be displayed simultaneously in real-time.

Hardware Requirements

- 3 Output Cards (driving 6 UXGA screens)
- 12 Input Cards (providing 144 source inputs)
- An ES3301-2 Card Frame.

System Capacity

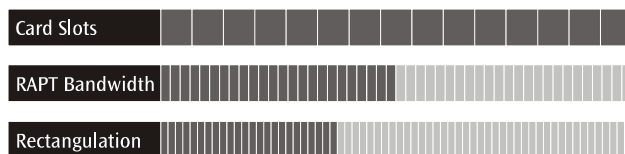

The limit of 144 real-time video source windows is imposed by the maximum number of card slots being used.

Expansion Options

Assuming that all video sources are using single-field de-interlace and are sampled at 4:2:2, only around 50% of the RAPT bandwidth is being used. Rectangulation is also well below its limit, so there is plenty of headroom for adding RGB graphics (VN-GLIMPSE) sources.

Scenario 4 – Maximum number of video sources on the largest display

Screen Layout

8 UXGA display devices are used to create a 4x2 tiled display. 132 video source windows are arranged as a 16x8 array. The total display size is 6400x2400 pixels, making each window 400x300 pixels.

1	2	3	4	5	6	7	8	9	10	11	12	13	14	15	16
17	18	19	20	21	22	23	24	25	26	27	28	29	30	31	32
33	34	35	36	37	38	39	40	41	42	43	44	45	46	47	48
49	50	51	52	53	54	55	56	57	58	59	60	61	62	63	64
65	66	67	68	69	70	71	72	73	74	75	76	77	78	79	80
81	82	83	84	85	86	87	88	89	90	91	92	93	94	95	96
97	98	99	100	101	102	103	104	105	106	107	108	109	110	111	112
113	114	115	116	117	118	119	120	121	122	123	124	125	126	127	128
129	130	131	132												

Because each window is smaller than the native source resolution, each source is scaled down to the required size by the Input Card. This greatly reduces the amount of source data needing to be transferred across the RAPT bus to the Output Card and allows a large number of sources to be displayed simultaneously in real-time.

Hardware Requirements

- 4 Output Cards (driving 8 UXGA screens)
- 11 Input Cards (providing 132 source inputs)
- An ES3301-2 Card Frame.

System Capacity

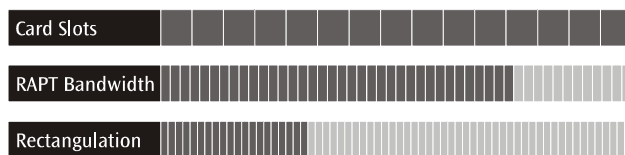

The limit of 132 real-time video source windows is imposed by the maximum number of card slots being used.

Expansion Options

Assuming that all video sources are using single-field de-interlace and are sampled at 4:2:2, only around 75% of the RAPT bandwidth is being used. Rectangulation is also well below its limit, so there is plenty of headroom for adding RGB graphics (VN-GLIMPSE) sources.

This page is intentionally left blank.

SECTION 4:

Maintenance

Component Replacement Procedures

Removing and Replacing a PSU (ES3301-2 only)

In the event of a PSU failure, an audible alarm will be triggered and the POWER indicator will show red. Also the normally-lit status indicator on the faulty PSU will be extinguished. The alarm will continue to sound until the fault condition has been removed.

A failed PSU can be removed and replaced without needing to power-down the VN-QUANTUM or remove it from a rack ('hot-swapping').

NOTE: *Disconnecting or powering-off a healthy PSU at any time will also sound the alarm.*

Always use an Electrosonic Replacement PSU, Part No. ES3301-P.

➤ Open the lower access panel by turning the latch knob a quarter-turn clockwise.

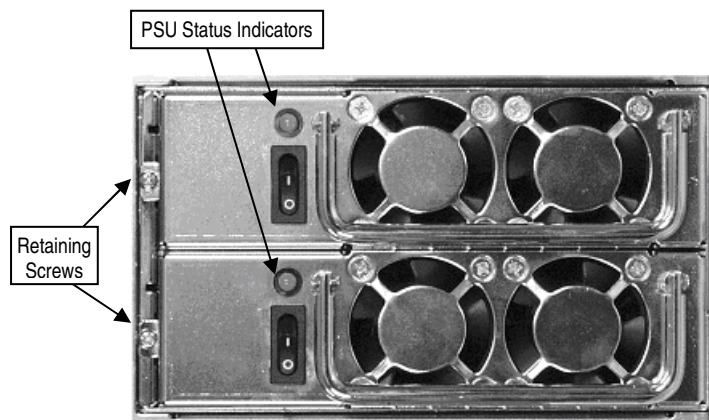

➤ Remove the retaining screw and withdraw the faulty PSU using the handle provided.

➤ Insert the replacement PSU and secure with the retaining bolt.

➤ Switch on the new PSU.

➤ Check that the status indicator is lit and that the alarm is reset.

Removing and Replacing a Cooling Fan

Always use an Electrosonic Replacement Fan, Part No. ES3301-F or ES3302-F.

- ✎ Remove the upper access panel by unscrewing the two thumbscrews.
- ✎ Unplug the supply lead to the faulty fan.
- ✎ Remove the single retaining screw from above the fan.

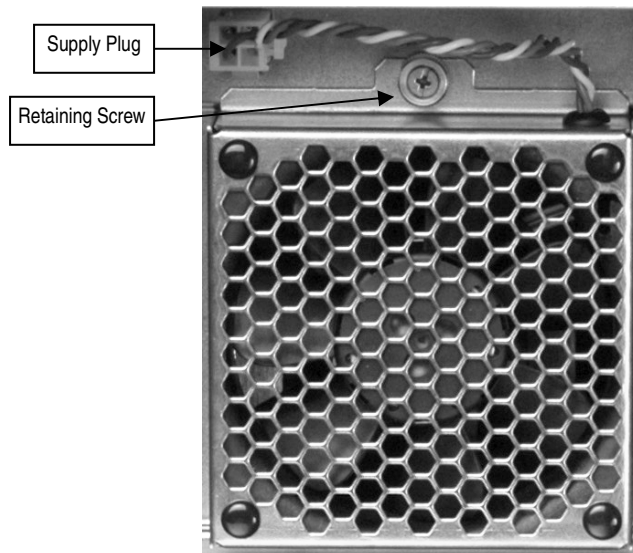

- ✎ Withdraw the fan by tilting the top forward and lifting away.

NOTE: When replacing the fan ensure that the two lugs (on the base of the fan housing) correctly locate inside the aperture in the card frame.

Cleaning the Ventilation Grilles & Filters

It is recommended that the front ventilation grilles and air filters are checked periodically for a build-up of dust. Excess dust deposits will reduce the efficiency of the cooling fans and may cause the unit to overheat.

To clean the grilles and filters, use a vacuum cleaner (and if necessary a soft brush) to remove any dust deposits.

This page is intentionally left blank.

SECTION 5:

Technical Data

ES3301-2 15-Slot Card Frame

Mechanical Data

Overall Dimensions:

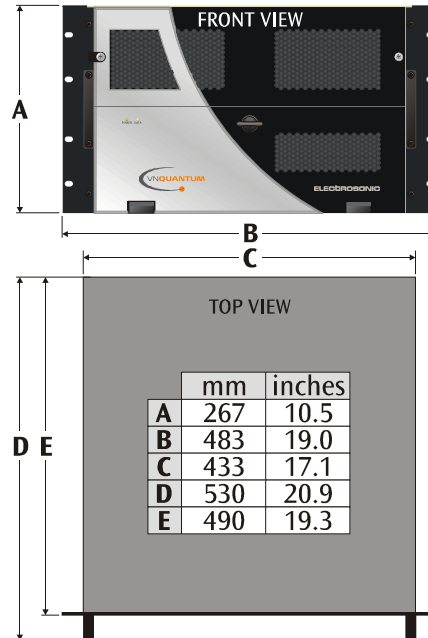

Weight: 23.5 kg (51.8 lbs) without cards.

Power Supply

- Supply Voltage: 110 – 230V A.C. nominal (90 – 264V A.C. absolute).
- Supply Frequency: 50 – 60 Hz nominal (47 – 63 Hz absolute).
- Max. Power Consumption: 300 – 500W
- Inlet Connector: IEC320 (C14).
- Mating Connector: IEC320 (C13); suitable 2m (6ft) cable supplied.

WARNING: THIS EQUIPMENT MUST BE GROUNDED/EARTHED.

Operating Environment

- Location: 19" Equipment Rack or Freestanding.
- Ambient Temperature: 5°C to 35°C (41°F to 95°F).
- Ambient Humidity: 85% maximum (non-condensing).
- Cooling Method: 4 x DC Axial Fan; user-serviceable.
- Typical Fan Life: >70,000 hours.
- Noise Level: 62dB @ 1 metre.

Conformance

- CE: EN 55103-1:1996:E2
EN 55103-2:1996:E2
EN 60950:2000
- UL: Designed to meet UL standards.

Operating System

Software: Windows® XP Embedded
+ Ardence® (VenturCom) RTX Real Time Extension
CPU: 1.8GHz Pentium® M.
Memory: 1GB DDR RAM
Data Transport: 64-bit 66/33MHz PCI Bus
Video Transport: 10Gbps RAPT Bus
Data Storage: Dual-Slot Compact Flash Drive.
Top Slot: Operating System.
Bottom Slot: System Backup or Image File Storage.

ES3302 & 3304 8-Slot Card Frame

Mechanical Data

Overall Dimensions:

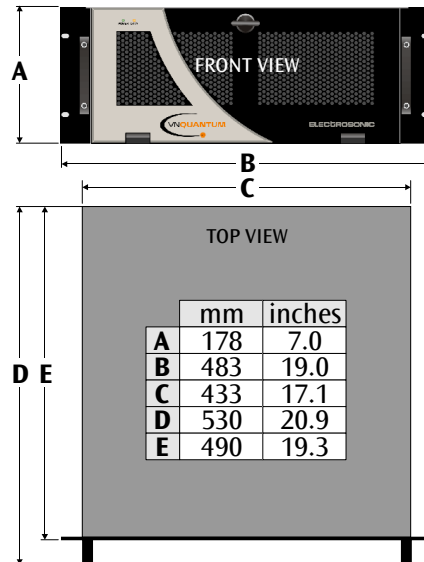

Weight: 15 kg (33 lbs) without cards.

Power Supply

- Supply Voltage: 110 – 230V A.C. nominal (90 – 264V A.C. absolute).
- Supply Frequency: 50 – 60 Hz nominal (47 – 63 Hz absolute).
- Max. Power Consumption: 500W
- Inlet Connector: IEC320 (C14).
- Mating Connector: IEC320 (C13); suitable 2m (6ft) cable supplied.

WARNING: THIS EQUIPMENT MUST BE GROUNDED/EARTHED.

Operating Environment

- Location: 19" Equipment Rack or Freestanding.
- Ambient Temperature: 5°C to 35°C (41°F to 95°F).
- Ambient Humidity: 85% maximum (non-condensing).
- Cooling Method: 2 x DC Axial Fan; user-serviceable.
- Typical Fan Life: >70,000 hours

Conformance

- CE: EN 55103-1:1996:E2
EN 55103-2:1996:E2
EN 60950:2000
- UL: Designed to meet UL standards.

Operating System

Software: Windows® XP Embedded
+ Ardence® (VenturCom) RTX Real Time Extension
CPU: 2.8GHz Pentium® IV.
Memory: 1GB DDR RAM
Data Transport: 32-bit PCI Bus
Video Transport: 10Gbps RAPT Bus
Data Storage: Single 40MB IDE Drive in removable caddy (not hot swap)
partitioned as.
C: for the operating system.
D: for configuration and image file storage.

Control Inputs/Outputs

The following control input/output connectors appear on the ES3301-2 and ES3302 / 3304 Card Frames.

CONTROL Port

Function: Connection to a VN-COMMANDER control PC.
 Connector Type: Shielded RJ-45 Socket.
 Pin-out Details:

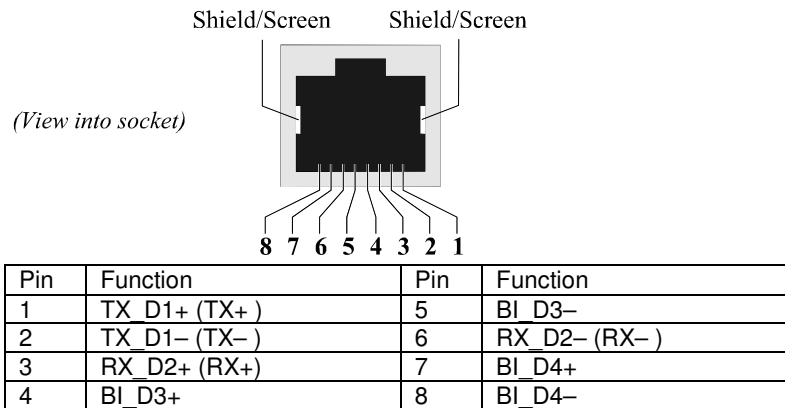

Mating Connector: Shielded RJ-45 Plug.
 Recommended Cable: Shielded twisted pair (STP).
 Max. Cable Length: 100 metres (330 feet).
 Comms Standard: 10/100BASE-T (Fast Ethernet)
 Default IP Address: Factory-set to 172.28.232.11. No DHCP option.
 User-definable via control software.

MEDIA I & II Ports (Not supported on the ES3304 VN-QUANTUM CONNECT)

Function: Connection to a local or wide area network for access to network content or VN-GLIMPSE sources.
 Connector Type: Shielded RJ-45 Socket.
 Pin-out Details:

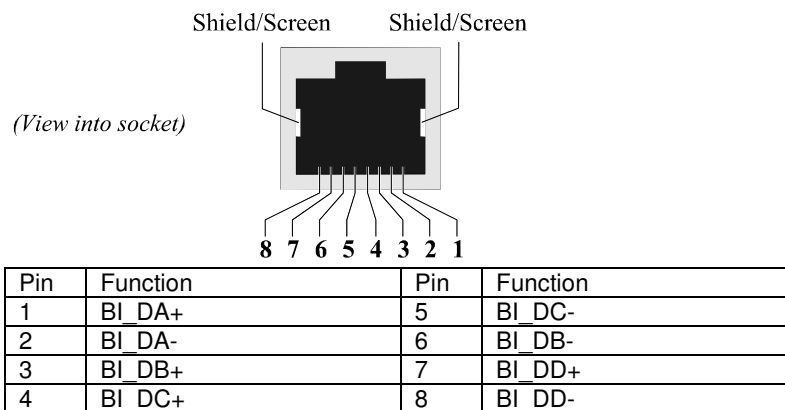

Mating Connector: Shielded RJ-45 Plug.
 Recommended Cable: Shielded twisted pair (STP).
 Max. Cable Length: 100 metres (330 feet).
 Comms Standard: 1000BASE-T (Gigabit Ethernet)
 Default IP Address: Factory-set to DHCP operation.
 Fixed IP address user-definable via control software.

Keyboard/Mouse (PS/2 Port)

Function: Connection for optional PS/2-compatible keyboard and/or mouse – not required during normal usage. Only required during commissioning and troubleshooting using the integral Quantum Control Panel facility. A splitter cable/adaptor is required to connect both a mouse and keyboard simultaneously to the ES3302 Card Frame.
 NOTE: PS/2 does not support hot-plugging.

Connector Type: 6-pin mini-DIN (female)
 Pin-out Details:

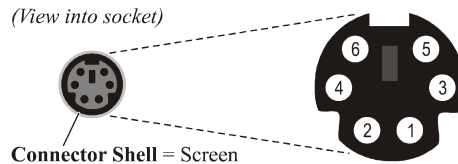

Pin	Function
1	Data
2	No connection
3	Ground
4	+5V supply*
5	Clock
6	No connection

* 5V on pin 4 limited to 200mA by thermal fuse.

Monitor

Function: Connection for optional monitor – not required during normal usage. Only required during commissioning and troubleshooting using the integral Quantum Control Panel facility.

Connector Type: 15-pin High Density D-type.
 Pin-out Details:

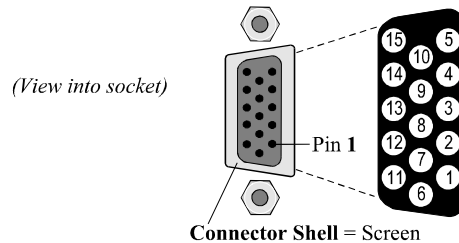

Pin	Function	Pin	Function	Pin	Function
1	Red	6	Gnd (Red)	11	NC
2	Green	7	Gnd (Green)	12	DDC Data
3	Blue	8	Gnd (Blue)	13	H Sync
4	NC	9	+5V Output*	14	V Sync
5	Ground	10	Gnd (Sync)	15	DDC Clock

* 5V on pin 9 limited to 200mA by thermal fuse.

- Mating Connector: 15-pin High Density D-type.
- Recommended Cable: 5 core miniature coaxial with overall screen, 75Ω characteristic impedance (e.g. Belden 1522A).
- Maximum Cable Length: 5 metres (16 feet)
- Signal Type: Analog RGB.
- Pixel Clock: 10MHz – 165MHz.
- Resolution: Up to 1600 x 1200 pixels (UXGA).
- Video Level: 0.7V into 75Ω.
- RGB Sync Mode: RGBHV (separate H & V sync).
- Sync Level: 2.4V minimum into 2.2KΩ.
- Scan Mode: Progressive.

USB Port

Function: Optional storage device or data upload/download – not required for normal operation.

Connector Type: USB A Socket.

Pin-out Details: 1=+5V
2=Data –
3=Data +
4=Ground

Mating Connector: USB A Plug with metal cover.

Recommended Cable: USB Cable.

Maximum Cable Length: 5 metres (16 feet).

Comms Standard: USB 2.

ES3310 Output Card

Function: Final composited video output to the target display. Sources can be derived from Video (via ES3311-2 Input Card), RGB and DVI Graphics, VN-GLIMPSE and Image Files. Provides up-scaling (magnification) of sources. Two output channels are provided per card.

Card Weight: 0.29 kg (0.63 lb).
Connector Type: DVI-I (female).
Pin-out Details:

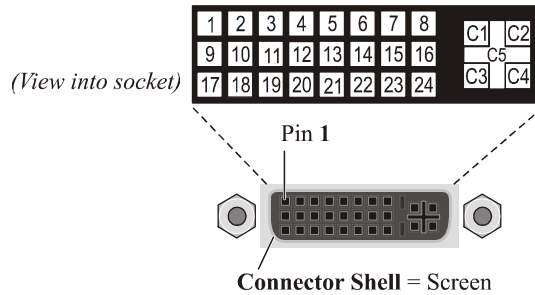

Digital Connections

Pin	Function	Pin	Function	Pin	Function
1	TMDS 2-	9	TMDS 1-	17	TMDS 0-
2	TMDS 2+	10	TMDS 1+	18	TMDS 0+
3	Ground (2/4)	11	Ground (1/3)	19	Ground (0/5)
4	No connection	12	No connection	20	No connection
5	No connection	13	No connection	21	No connection
6	DDC Clock	14	+5V supply*	22	Ground (Clk)
7	DDC Data	15	Ground (for 5v)	23	TMDS Clock+
8	Analog V-Sync	16	Hot Plug Detect	24	TMDS Clock-

* 5V on pin 14 limited to 200mA by thermal fuse.

Analog Connections

Pin	Function
C1	Red Signal
C2	Green Signal
C3	Blue Signal
C4	Horizontal Sync
C5	Ground

NOTE:
Analog Vertical Sync is on pin 8.

- Mating Connector:** DVI-D, DVI-A or DVI-I (male).
- Recommended Cable:** Digital: DVI Single or Dual Link Digital Video Cable; Analog: DVI Analog Video Cable.
- Max. Cable Length:** Digital: 5 metres (16 feet). Analog: 10 metres (32 feet)
- Signal Type:** DVI-1.0 or Analog RGB.
- RGB Levels:** Video: 0.7V ±1% into 75Ω; Sync: 2.4V into 2K2.
- RGB Sync:** RBGHV (H & V TTL sync).
- Pixel Clock:** 25MHz – 165MHz.
- Output Resolution:** SVGA (600 x 800 pixels) to 1920x1080 resolution.
- Color Depth:** 24-bit maximum.
- Scan Rate:** 50 or 60 Hz.
- Scan Mode:** Progressive.
- DDC:** Not supported.
- Scaling Engine:** 370Mpixels/s real-time using ES patented convolver.
- Scaling Factor:** Variable from unity down to 1/16 of native resolution horizontally and vertically.

ES3311-2 Video Input Card

Function: Input for up to 12 composite video (CVBS) and/or s-video (YC) sources. Provides digitization and down-scaling of sources. Two connectors are provided – one for composite or S-Video luma (Y) signals, the other for S-Video chroma (C) signals. A suitable breakout cable is supplied (ES3311-CA, see page 100). Full source auto-detection is provided.

Card Weight: 0.26 kg (0.56 lb).

Connector Type: 2 x 26-pin High Density D-type (female).

Pin-out Details: *Top Connector (Composite or S-Video Y):*

Pin	Function	Pin	Function	Pin	Function
1	CVBS / Y 1 in	9	ground	18	ground
2	CVBS / Y 2 in	10	ground	19	CVBS / Y 7 in
3	CVBS / Y 3 in	11	ground	20	CVBS / Y 8 in
4	CVBS / Y 4 in	12	ground	21	CVBS / Y 9 in
5	CVBS / Y 5 in	13	ground	22	CVBS / Y 10 in
6	CVBS / Y 6 in	14	ground	23	CVBS / Y 11 in
7	ground	15	ground	24	CVBS / Y 12 in
8	ground	16	ground	25	ground
		17	ground	26	ground

Lower Connector (S-Video C only):

Pin	Function	Pin	Function	Pin	Function
1	C 1 in	9	ground	18	ground
2	C 2 in	10	ground	19	C 7 in
3	C 3 in	11	ground	20	C 8 in
4	C 4 in	12	ground	21	C 9 in
5	C 5 in	13	ground	22	C 10 in
6	C 6 in	14	ground	23	C 11 in
7	ground	15	ground	24	C 12 in
8	ground	16	ground	25	ground
		17	ground	26	ground

Note: Ground pins 9 thru 18 must be linked with thick copper wire and all cable screens connected to it. The connector shell must also be connected to ground.

Mating Connector: 26-pin High Density D-type (male)
(see *ES3311-CA Breakout Cable, page 100*)

Recommended Cable: Low-loss 75Ω co-axial
(see *ES3311-CA Breakout Cable, page 100*)

Maximum Cable Length: 10 metres (32 feet).

Signal Type: Composite (CVBS) or S-Video (YC).

Video Standards: PAL – B,D,G,H,I,M,N,Nc (no support for PAL60);
NTSC – J,M,4.43;
SECAM – B,D,G,K,K1,L.
Macrovision compatible.

Video Level: 0.7V (max 2.0V).
AGC down to 20% of signal.

Sampling Format: 4:2:2.

Color Depth: 24 bit.

De-interlacing: Single Field Interpolation;
Three Field Interpolation.

Scaling Engine: 370Mpixels/s real-time using ES patented convolver.

Scaling Factor: Variable from unity down to 1/16 of native resolution horizontally and vertically.

ES3311-CA Breakout Cable (for video input card)

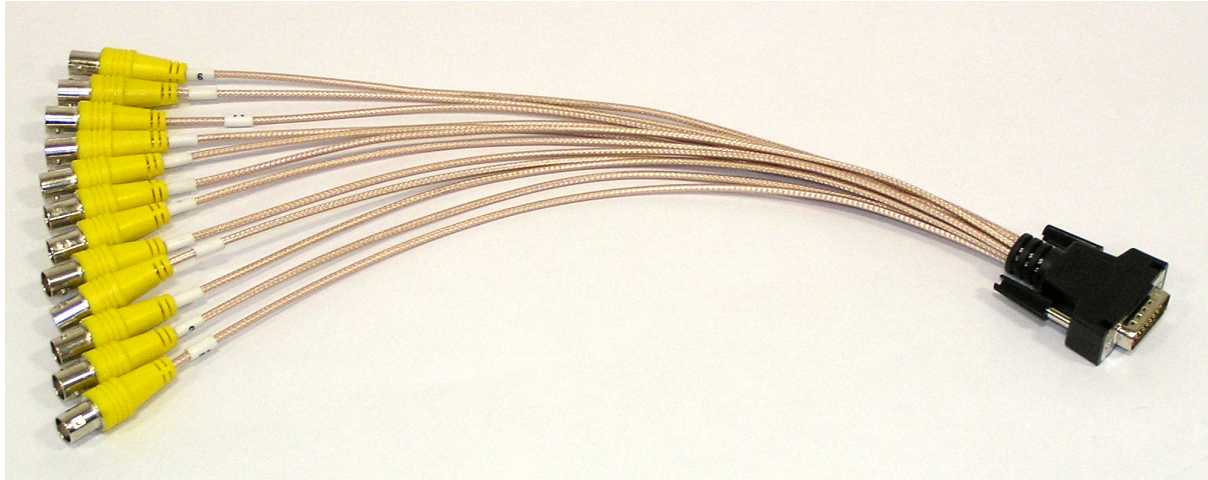

Function: A breakout/splitter cable for use with the ES3311-2 Video Input Card. Provides a separate flying lead with inline connector for each of the 12 input channels. The connectors are labeled 1 thru 12.

Connector Type: BNC (female).

Mating Connector: BNC (male).

Lead Length: 400mm nominal.

ES3312 RGB Input Card

Function: Input for 1 or 2 analog RGB or component YPrPb sources. Provides digitization and down-scaling of sources. Full source auto-detection is provided.

Card Weight: 0.26 kg (0.56 lb).

Connector Type: 2 x 15-pin High Density D-type (female).

Pin-out Details:

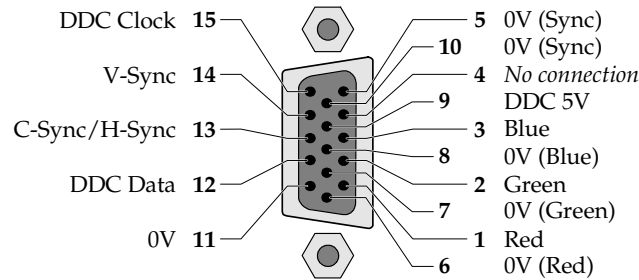

Connector Shell = Screen

Top Connector = Input 1

Lower Connector = Input 2

Mating Connector: 15-pin High Density D-type (male).

Recommended Cable: Low-loss 75Ω co-axial.

Maximum Cable Length: 10 metres (32 feet).

Signal Type: Analog RGB;
Component YPrPb.

Video Standards: Up to UXGA or WUXGA @ 75Hz;
HDTV 1080i, 1080p, or 720p.

Video Level: 0.7V (max 2.0V).

Sampling Format: 4:4:4.

Color Depth: 24 bit.

De-interlacing: Single Field Interpolation;
Three Field Interpolation.

Scaling Engine: 370Mpixels/s real-time using ES patented convolver.

Scaling Factor: Variable from unity down to 1/16 of native resolution horizontally and vertically.

ES3314 DVI Input Card

Function: Input for 1 or 2 digital video or graphics sources. Provides down-scaling of sources as required. Full source auto-detection is provided.

Card Weight: 0.26 kg (0.56 lb).
Connector Type: 2 x DVI-D (female).
Pin-out Details:

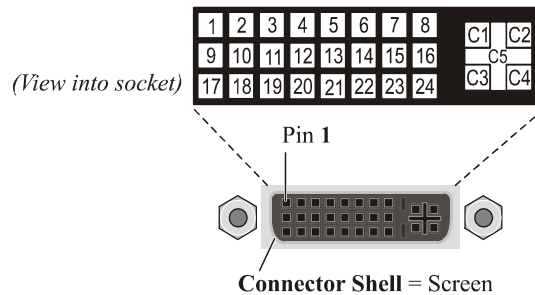

Top Connector = Input 1
Lower Connector = Input 2

Pin	Function	Pin	Function	Pin	Function
1	TMDS 2-	9	TMDS 1-	17	TMDS 0-
2	TMDS 2+	10	TMDS 1+	18	TMDS 0+
3	Ground (2/4)	11	Ground (1/3)	19	Ground (0/5)
4	No connection	12	No connection	20	No connection
5	No connection	13	No connection	21	No connection
6	DDC Clock	14	+5V Reference	22	Ground (Clk)
7	DDC Data	15	Ground (for 5v)	23	TMDS Clock+
8	No connection	16	Hot Plug Detect	24	TMDS Clock-

NOTE: All analog pins (C1 – C5) are not connected.

Mating Connector: DVI-D (male).
Recommended Cable: DVI Single or Dual Link Video Cable
Max. Cable Length: 5 metres (16 feet).
Signal Type: DVI (PanelLink[®] TMDS)
Video Standards: Up to UXGA or WUXGA @ 75Hz;
 HDTV 1080i, 1080p, or 720p.
 RGB

De-interlacing: Single Field Interpolation;
 Three Field Interpolation.

Scaling Engine: 370Mpixels/s real-time using ES patented convolver.
Scaling Factor: Variable from unity down to 1/16 of native resolution horizontally and vertically.

APPENDIX A:

Guide to IP Addressing

What is an IP Address?

A full explanation of IP addressing is beyond the scope of this user guide. However the following details will provide you with enough information to get started.

An IP Address is a 32-bit binary number that is used to identify each device on an Ethernet network. This number is usually represented by four decimal numbers (each in the range 0 to 255) separated by dots, *e.g.* 198.123.34.240. This is called 'dotted decimal notation'.

An IP Address is divided into two parts:

- the 'network identifier', and
- the 'host identifier'.

On a given network each address must have the same network identifier value but have a unique host identifier. There are, therefore, different 'classes' of address which define:

- the range of valid addresses, and
- which parts of the address are used for the network and host identifiers.

The most common IP Address classes are:

Class Name	Valid Address Range	Identifier Arrangement*
Class A	0.0.0.1 to 127.255.255.254	NNN.HHH.HHH.HHH
Class B	128.0.0.1 to 191.255.255.254	NNN.NNN.HHH.HHH
Class C	192.0.0.1 to 223.255.255.254	NNN.NNN.NNN.HHH

*Where: NNN = Network identifier
 HHH = Host identifier

Choosing IP Addresses

If your VN Processor(s) and control PC are directly connected or connected via their own independent network, then follow the guidelines below for choosing your IP Address(es).

However, if you intend connecting your VN Processor(s) and control PC to an existing network, you will need to advise the network administrator and ask them to allocate suitable addresses to you.

On an independent (private) network you can (in theory) use just about any addresses you wish. However, it is generally recommended that you use the Class C format (*i.e.* from 192.0.0.1 up to 223.255.255.253). In addition, some address ranges from each of the network classes have been set aside and designated “reserved” or “private” address ranges:

Class A:	10.0.0.0	to	10.255.255.255
Class B:	172.16.0.0	to	172.31.255.255
Class C:	192.168.0.0	to	192.168.255.255

These addresses not used or routed on the Internet and are specifically reserved for use by private networks.

Remember that there are two rules for choosing IP Addresses:

- the network identifier must be the same for each address, and
- the host identifier must be unique for each address.

Applying these rules to Class C addresses, it can be seen that the first three decimal values of your IP Addresses must all be the same, while the last value is used to uniquely identify each device. The following is an example of a valid Class C addressing scheme:

Device	IP Address
Device 1	208.132.180.41
Device 2	208.132.180.42
Device 3	208.132.180.43

NOTE: *The host identifiers (e.g. 41, 42, and 43 in the above example) need not be sequential or in any particular order. However, it is recommended that you group the numbers for simplicity.*

The following is an example of an **invalid** Class C addressing scheme:

Device	IP Address
Device 1	208.132.180.41
Device 2	192.157.180.42
Device 3	209.100.123.43

NOTE: *These are invalid because the network identifier for each address is not the same, even though each IP Address is unique.*

You can use the Ping command from your computer to check that a device at a particular address is responding correctly (see page 107).

Subnet Mask

The Subnet Mask is another 32-bit binary number that is used to 'mask' certain bits of the IP Address. This provides a method of extending the number of network options for a given IP Address. It works by allowing part of the host identifier to be used as a 'subnet identifier'. Any further explanation of this facility is not relevant to VISION NETWORK.

However, it is important that you set the correct value for the Subnet Mask. The basic values depend on the class of IP Address being used:

Class Name	Subnet Mask
Class A	255.0.0.0
Class B	255.255.0.0
Class C	255.255.255.0

Using the 'Ping' Utility to Test Communications

You can test for communications between a Windows computer and another device on the same network by using the Windows Ping utility.

- ☞ From the Windows Desktop of the computer, click on the **Start** button, and select **Run** from the pop-up menu.

The Run dialog box will appear.

- ☞ In the Open box, type in the following command:

```
ping xxx.xxx.xxx.xxx -t
```

where xxx.xxx.xxx.xxx is the IP Address of the device (e.g. a VN Processor) that you want to test.

- ☞ Click on the **OK** button or press the **Enter** key.

A text window will appear showing a series of response messages; these are explained below.

- ☞ To stop the ping utility, press **Ctrl + C** on the keyboard.

Response Messages

When you run the Ping utility, it will display a series of response messages, which you can use to determine the state of the communications link. For example, if you have 'pinged' a VN Processor with the address 208.132.180.48, you should get a message similar to the following:

```
Reply from 208.132.180.48: bytes=32 time=2ms TTL=32
```

This is the correct response which indicates that the device at the specified address is communicating correctly. Note that the response 'time' value may vary according to network traffic.

If you get the message...

```
Request timed out.
```

...this indicates that there has been no response from the specified address. Either the processor is not receiving data from the computer or not sending data back. Check that the VN Processor is powered-up and set to the same address that you 'pinged'. Also, check that you are using the correct type of connecting cables (i.e. 'straight through' or 'crossover') and that they are not damaged or faulty.

If you get the message...

```
Reply from 208.132.180.48: Destination host unreachable.
```

...this indicates that the IP Address of the computer is not in the same 'class' (or subnet) as that of the VN Processor. Check that the SubNet Mask on both the computer and the VN Processor are set to the same value (see page 106). Also check that both IP Address are within the correct range for the chosen class and are compatible (see page 105).

This page is intentionally left blank.

ELECTROSONIC

UK - London

Tel: +44 1322 222 211 Fax: +44 1322 282 282
E-mail: information@electrosonic-uk.com

UK - Edinburgh

Tel: +44 131 447 6211 Fax: +44 131 452 8372
E-mail: info@avc-edinburgh.com

USA - Minneapolis

Tel: +1 952 931 7500 Fax: +1 952 938 9311
E-mail: information@electrosonic.com

USA - Los Angeles

Tel: +1 818 566 3045 Fax: +1 818 566 4923
E-mail: information@electrosonic.com

USA - New York

Tel: +1 609 349 8600 Fax: +1 718 349 8635
E-mail: information@electrosonic.com

USA - Orlando

Tel: +1 407 839 1154 Fax: +1 407 839 2055
E-mail: information@electrosonic.com

Sweden - Stockholm

Tel: +46 8 522 057 00 Fax: +46 8223 181
E-mail: info.sweden@electrosonic.com

Finland - Helsinki

Tel: +358 9 251 55500 Fax: +358 9 565 1774
E-mail: asiakaspalvelu@electrosonic.fi

UAE - Dubai

Tel: +971 4 332 4027 Fax: +971 4 332 8871
E-mail: infoUAE@electrosonic.com

China - Shanghai

Tel: +86 21 6249 2522 Fax: +86 21 6249 3358
E-mail: infoNEasia@electrosonic.com

Hong Kong

Tel: +852 2525 1828 Fax: +852 2877 5811
Email: infoasia@electrosonic-uk.com

Web Site: www.electrosonic.com

Copyright © 2008 ELECTROSONIC Ltd
All rights reserved

Part No. I456GB issue 5